

MBR1030CT-MBR1060CT

SCHOTTKY BARRIER RECTIFIER

FEATURES

- Schottky Barrier Chip
- Guard Ring Die Construction for Transient Protection
- Low Power Loss, High Efficiency
- High Surge Capability
- High Current Capability and Low Forward Voltage Drop
- For Use in Low Voltage, High Frequency Inverters, Free Wheeling, and Polarity Protection Applications

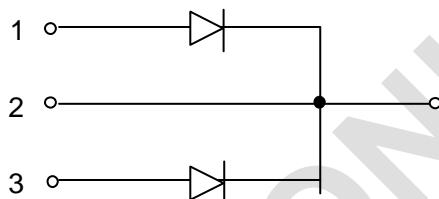
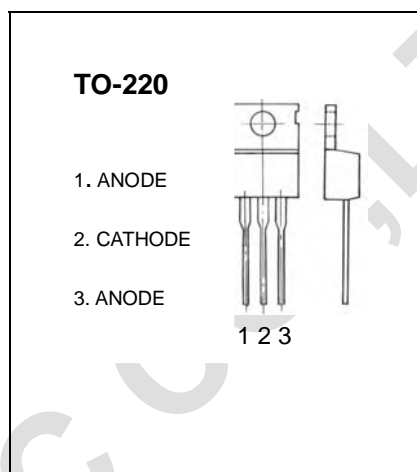

ELECTRICAL CHARACTERISTICS (Tamb=25°C unless otherwise specified)

Characteristic	Symbol	MBR 1030CT	MBR 1035CT	MBR 1040CT	MBR 1045CT	MBR 1050CT	MBR 1060CT	Unit
Peak Repetitive Reverse Voltage	V_{RRM}							
Working Peak Reverse Voltage	V_{RWM}	30	35	40	45	50	60	V
DC Blocking Voltage	V_R							
PMS Reverse Voltage	$V_{R(RMS)}$	21	24.5	28	31.5	35	42	V
Average Rectified Output Current (Note 1) @ $T_C=105^\circ\text{C}$	I_O	10						A
Non-Repetitive Peak Forward Surge Current 8.3ms Single half sine-wave superimposed on rated load (JEDEC Method)	I_{FSM}	125						A
Repetitive Peak Reverse Surge Current @ $t \leq 2.0\mu\text{s}$	I_{RRM}	1.0						A
Forward Voltage Drop @ $I_F=5.0\text{A}, T_C=125^\circ\text{C}$ @ $I_F=5.0\text{A}, T_C=25^\circ\text{C}$ @ $I_F=10\text{A}, T_C=25^\circ\text{C}$	V_{FM}		0.57			0.70		V
			0.70			0.80		
			0.84			0.95		
Peak Reverse Current @ $T_C=25^\circ\text{C}$ at Rated DC Blocking Voltage @ $T_C=125^\circ\text{C}$	I_{RM}	0.1						mA
		15						
Typical Junction Capacitance (Note 2)	C_j	150						pF
Operating and Storage Temperature Range	T_j, T_{STG}	-65 to +150						$^\circ\text{C}$

Notes: 1. Thermal resistance junction to case mounted heat sink.

2. Measured at 1.0MHz and applied reverse voltage of 4.0V DC.