

To our customers,

---

## Old Company Name in Catalogs and Other Documents

---

On April 1<sup>st</sup>, 2010, NEC Electronics Corporation merged with Renesas Technology Corporation, and Renesas Electronics Corporation took over all the business of both companies. Therefore, although the old company name remains in this document, it is a valid Renesas Electronics document. We appreciate your understanding.

Renesas Electronics website: <http://www.renesas.com>

April 1<sup>st</sup>, 2010  
Renesas Electronics Corporation

Issued by: Renesas Electronics Corporation (<http://www.renesas.com>)

Send any inquiries to <http://www.renesas.com/inquiry>.

## Notice

1. All information included in this document is current as of the date this document is issued. Such information, however, is subject to change without any prior notice. Before purchasing or using any Renesas Electronics products listed herein, please confirm the latest product information with a Renesas Electronics sales office. Also, please pay regular and careful attention to additional and different information to be disclosed by Renesas Electronics such as that disclosed through our website.
2. Renesas Electronics does not assume any liability for infringement of patents, copyrights, or other intellectual property rights of third parties by or arising from the use of Renesas Electronics products or technical information described in this document. No license, express, implied or otherwise, is granted hereby under any patents, copyrights or other intellectual property rights of Renesas Electronics or others.
3. You should not alter, modify, copy, or otherwise misappropriate any Renesas Electronics product, whether in whole or in part.
4. Descriptions of circuits, software and other related information in this document are provided only to illustrate the operation of semiconductor products and application examples. You are fully responsible for the incorporation of these circuits, software, and information in the design of your equipment. Renesas Electronics assumes no responsibility for any losses incurred by you or third parties arising from the use of these circuits, software, or information.
5. When exporting the products or technology described in this document, you should comply with the applicable export control laws and regulations and follow the procedures required by such laws and regulations. You should not use Renesas Electronics products or the technology described in this document for any purpose relating to military applications or use by the military, including but not limited to the development of weapons of mass destruction. Renesas Electronics products and technology may not be used for or incorporated into any products or systems whose manufacture, use, or sale is prohibited under any applicable domestic or foreign laws or regulations.
6. Renesas Electronics has used reasonable care in preparing the information included in this document, but Renesas Electronics does not warrant that such information is error free. Renesas Electronics assumes no liability whatsoever for any damages incurred by you resulting from errors in or omissions from the information included herein.
7. Renesas Electronics products are classified according to the following three quality grades: “Standard”, “High Quality”, and “Specific”. The recommended applications for each Renesas Electronics product depends on the product’s quality grade, as indicated below. You must check the quality grade of each Renesas Electronics product before using it in a particular application. You may not use any Renesas Electronics product for any application categorized as “Specific” without the prior written consent of Renesas Electronics. Further, you may not use any Renesas Electronics product for any application for which it is not intended without the prior written consent of Renesas Electronics. Renesas Electronics shall not be in any way liable for any damages or losses incurred by you or third parties arising from the use of any Renesas Electronics product for an application categorized as “Specific” or for which the product is not intended where you have failed to obtain the prior written consent of Renesas Electronics. The quality grade of each Renesas Electronics product is “Standard” unless otherwise expressly specified in a Renesas Electronics data sheets or data books, etc.
  - “Standard”: Computers; office equipment; communications equipment; test and measurement equipment; audio and visual equipment; home electronic appliances; machine tools; personal electronic equipment; and industrial robots.
  - “High Quality”: Transportation equipment (automobiles, trains, ships, etc.); traffic control systems; anti-disaster systems; anti-crime systems; safety equipment; and medical equipment not specifically designed for life support.
  - “Specific”: Aircraft; aerospace equipment; submersible repeaters; nuclear reactor control systems; medical equipment or systems for life support (e.g. artificial life support devices or systems), surgical implantations, or healthcare intervention (e.g. excision, etc.), and any other applications or purposes that pose a direct threat to human life.
8. You should use the Renesas Electronics products described in this document within the range specified by Renesas Electronics, especially with respect to the maximum rating, operating supply voltage range, movement power voltage range, heat radiation characteristics, installation and other product characteristics. Renesas Electronics shall have no liability for malfunctions or damages arising out of the use of Renesas Electronics products beyond such specified ranges.
9. Although Renesas Electronics endeavors to improve the quality and reliability of its products, semiconductor products have specific characteristics such as the occurrence of failure at a certain rate and malfunctions under certain use conditions. Further, Renesas Electronics products are not subject to radiation resistance design. Please be sure to implement safety measures to guard them against the possibility of physical injury, and injury or damage caused by fire in the event of the failure of a Renesas Electronics product, such as safety design for hardware and software including but not limited to redundancy, fire control and malfunction prevention, appropriate treatment for aging degradation or any other appropriate measures. Because the evaluation of microcomputer software alone is very difficult, please evaluate the safety of the final products or system manufactured by you.
10. Please contact a Renesas Electronics sales office for details as to environmental matters such as the environmental compatibility of each Renesas Electronics product. Please use Renesas Electronics products in compliance with all applicable laws and regulations that regulate the inclusion or use of controlled substances, including without limitation, the EU RoHS Directive. Renesas Electronics assumes no liability for damages or losses occurring as a result of your noncompliance with applicable laws and regulations.
11. This document may not be reproduced or duplicated, in any form, in whole or in part, without prior written consent of Renesas Electronics.
12. Please contact a Renesas Electronics sales office if you have any questions regarding the information contained in this document or Renesas Electronics products, or if you have any other inquiries.

(Note 1) “Renesas Electronics” as used in this document means Renesas Electronics Corporation and also includes its majority-owned subsidiaries.

(Note 2) “Renesas Electronics product(s)” means any product developed or manufactured by or for Renesas Electronics.

**SMALL, GENERAL-PURPOSE  
4-BIT SINGLE-CHIP MICROCONTROLLERS**

The  $\mu$ PD17145(A1), 17147(A1), and 17149(A1) are 4-bit single-chip microcontrollers integrating an 8-bit A/D converter (4 channels), a timer function (3 channels), and a serial interface.

These microcontrollers employ a CPU of the general-purpose register type that can execute direct memory operations and direct memory-to-memory data transfer for efficient programming. All the instructions consist of 16 bits per word.

In addition, a one-time PROM version, the  $\mu$ PD17P149, is also available for program evaluation.

**The functions of these microcontrollers are described in detail in the following User's Manual. Be sure to read the following manual when designing your system:**

**$\mu$ PD17145 Subseries User's Manual: IEU-1383**

**FEATURES**

- 17K architecture : General-purpose register type  
: Instruction length fixed to 16 bits
- Program memory (ROM) :  $\mu$ PD17145(A1) : 2 KB (1024  $\times$  16 bits)  
:  $\mu$ PD17147(A1) : 4 KB (2048  $\times$  16 bits)  
:  $\mu$ PD17149(A1) : 8 KB (4096  $\times$  16 bits)
- Data memory (RAM) : 110  $\times$  4 bits
- External interrupt : 1 (INT pin, with sense input)
- Instruction execution time : 2  $\mu$ s (at 8 MHz: ceramic oscillation)
- 8-bit A/D converter : 4 channels, absolute accuracy:  $\pm 1.5$  LSB MAX. ( $V_{DD} = 4.0$  to 5.5 V)
- Timer : 3 channels
- Serial interface : 1 channel (clocked 3-wire)
- POC circuit (mask option)
- Operating voltage :  $V_{DD} = 2.7$  to 5.5 V (at 400 kHz to 2 MHz)  
:  $V_{DD} = 4.5$  to 5.5 V (at 400 kHz to 8 MHz)
- Operating temperature :  $T_a = -40$  to +110  $^{\circ}$ C

**APPLICATIONS**

Automotive electronics, etc.

**Unless contextually excluded, references in this data sheet to the  $\mu$ PD17149 (A1) mean the  $\mu$ PD17145 (A1) and  $\mu$ PD17147 (A1).**

The information in this document is subject to change without notice.

**ORDERING INFORMATION**

Part Number	Package	Quality Grade
μPD17145CT(A1)-xxx	28-pin plastic shrink DIP (400 mil)	Special
μPD17145GT(A1)-xxx	28-pin plastic SOP (375 mil)	Special
μPD17147CT(A1)-xxx	28-pin plastic shrink DIP (400 mil)	Special
μPD17147GT(A1)-xxx	28-pin plastic SOP (375 mil)	Special
μPD17149CT(A1)-xxx	28-pin plastic shrink DIP (400 mil)	Special
μPD17149GT(A1)-xxx	28-pin plastic SOP (375 mil)	Special

**Remark** xxx indicates ROM code suffix.

Please refer to "Quality Grades on NEC Semiconductor Devices" (Document No. C11531E) published by NEC Corporation to know the specification of quality grade on the devices and its recommended applications.

FUNCTION LIST

Part Number	μPD17145 (A1)	μPD17147 (A1)	μPD17149 (A1)
Item			
ROM capacity	2 KB (1024 × 16 bits)	4 KB (2048 × 16 bits)	8 KB (4096 × 16 bits)
RAM capacity	110 × 4 bits		
Stack	Address stack × 5, interrupt stack × 3		
I/O ports	23 { <ul style="list-style-type: none"> <li>• I/O : 20</li> <li>• Input : 2</li> <li>• Sense input (INT pin<sup>Note</sup>) : 1</li> </ul>		
A/D converter input	4 channels (shared with port pins), absolute accuracy: ±1.5 LSB MAX.		
Timer	3 channels { <ul style="list-style-type: none"> <li>• 8-bit timer/counter: 2 channels (can be used as 1 channel of 16-bit timer)</li> <li>• 7-bit basic interval timer: 1 channel (can be used as watchdog timer)</li> </ul>		
Serial interface	1 channel (3-wire)		
Interrupt	<ul style="list-style-type: none"> <li>• Multiple interrupt by hardware (3 levels MAX.)</li> <li>• External interrupt (INT): 1 {               <ul style="list-style-type: none"> <li>Rising edge, falling edge, or both rising and falling edges selectable for detection.</li> </ul> </li> <li>• Internal interrupt: 4 {               <ul style="list-style-type: none"> <li>• Timer 0 (TM0)</li> <li>• Timer 1 (TM1)</li> <li>• Basic interval timer (BTM)</li> <li>• Serial interface (SIO)</li> </ul> </li> </ul>		
Instruction execution time	2 μs (at 8 MHz, ceramic oscillation)		
Standby function	HALT, STOP		
POC circuit	Mask option (Can be used in application circuit that operates on V <sub>DD</sub> = 5 V ± 10 %, 400 kHz to 4 MHz)		
Operating voltage	2.7 to 5.5 V (at 400 kHz to 2 MHz) 4.5 to 5.5 V (at 400 kHz to 8 MHz)		
Package	28-pin plastic shrink DIP (400 mil) 28-pin plastic SOP (375 mil)		
One-time PROM version	μPD17P149 ( <ul style="list-style-type: none"> <li>Quality grade is "standard" and not (A1).</li> <li>Operating temperature range: T<sub>a</sub> = -40 to +85 °C</li> </ul> )		

**Note** The INT pin is used as an input pin (sense input) when the external interrupt function is not used. The status of this pin is read by using the INT flag of a control register, not by a port register.

**Caution** The PROM version is functionally compatible with the mask ROM versions but its internal circuit and part of the electrical characteristics are different from those of the mask ROM versions. To replace the PROM version with a mask ROM version, thoroughly conduct application evaluation by using a sample of the mask ROM version.

**PIN CONFIGURATION (Top View)**

**28-pin plastic shrink DIP (400 mil)**  
**28-pin plastic SOP (375 mil)**

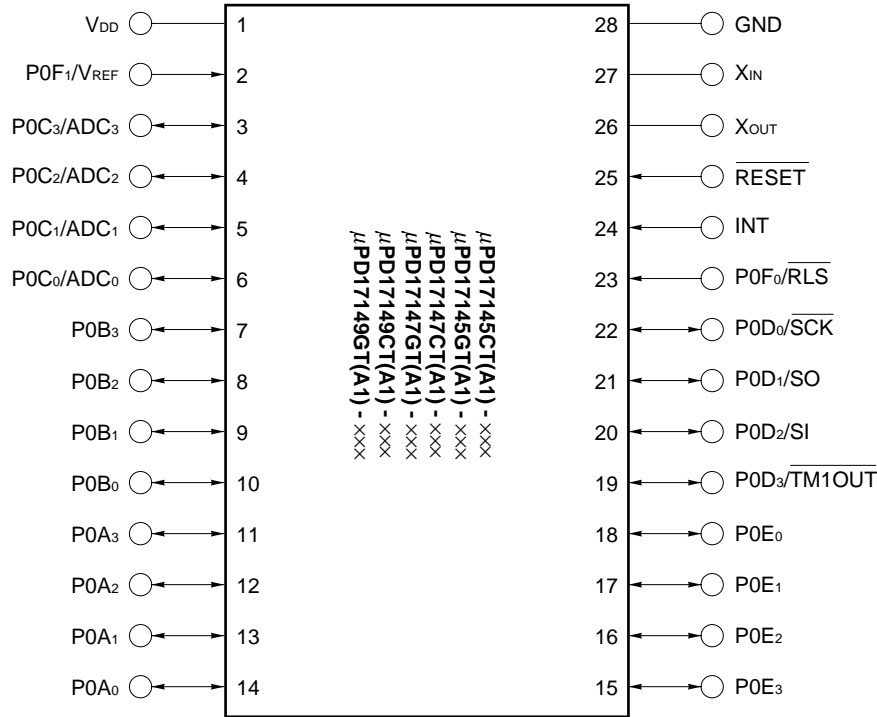

- ADC<sub>0</sub>-ADC<sub>3</sub> : analog input
- GND : ground
- INT : external interrupt input
- P0A<sub>0</sub> to P0A<sub>3</sub> : port 0A
- P0B<sub>0</sub> to P0B<sub>3</sub> : port 0B
- P0C<sub>0</sub> to P0C<sub>3</sub> : port 0C
- P0D<sub>0</sub> to P0D<sub>3</sub> : port 0D
- P0E<sub>0</sub> to P0E<sub>3</sub> : port 0E
- P0F<sub>0</sub> and P0F<sub>1</sub> : port 0F
- RESET : reset input
- RLS : standby release signal input
- SCK : serial clock I/O
- SI : serial data input
- SO : serial data output
- TM1OUT : timer 1 output
- V<sub>DD</sub> : power
- V<sub>REF</sub> : A/D converter reference voltage
- X<sub>IN</sub>, X<sub>OUT</sub> : for system clock oscillation

BLOCK DIAGRAM

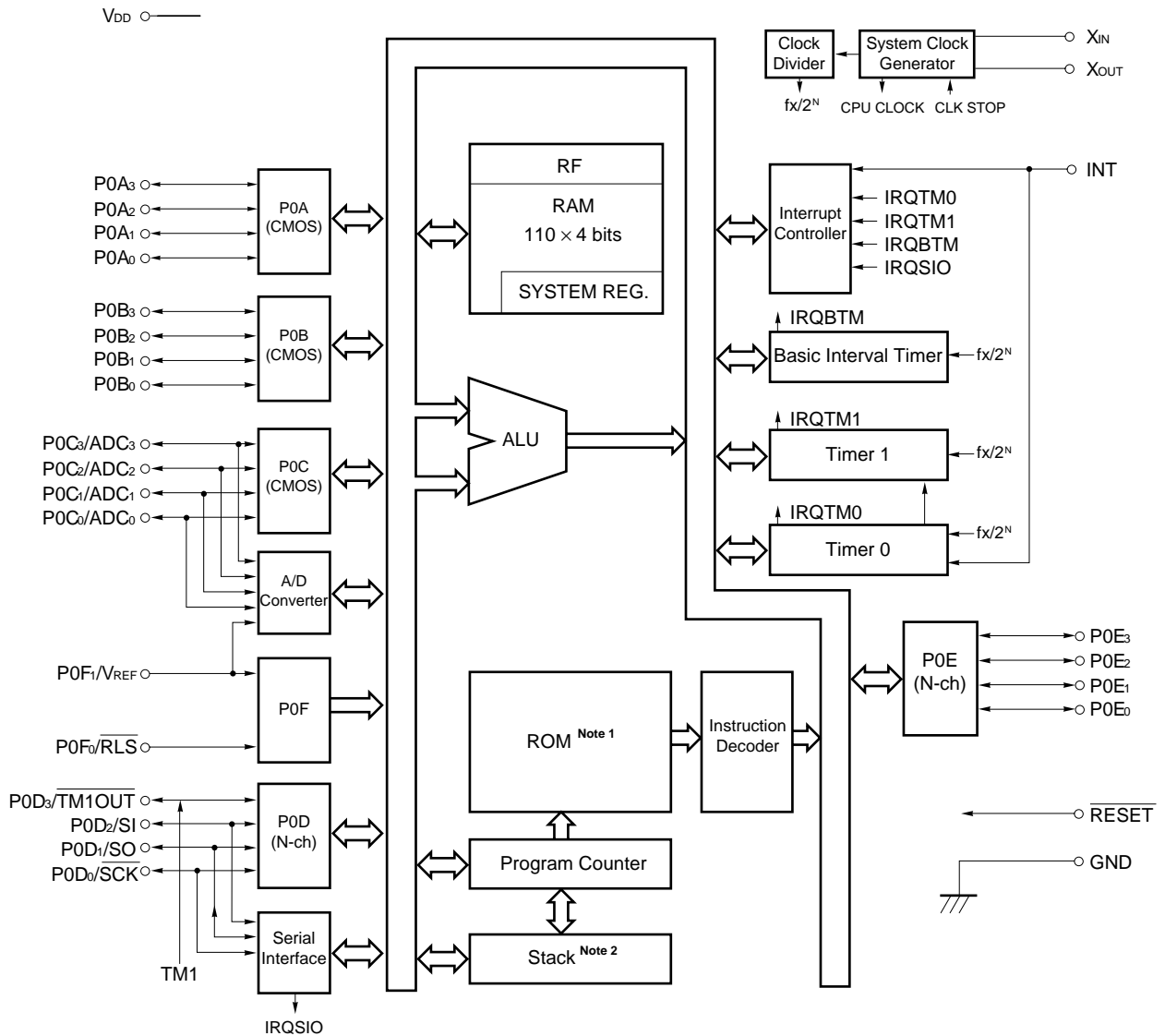

**Notes 1.** The ROM capacity of each product is as follows:

1024 × 16 bits: μPD17145(A1)

2048 × 16 bits: μPD17147(A1)

4096 × 16 bits: μPD17149(A1)

**2.** The stack capacity of each product is as follows:

5 × 10 bits: μPD17145(A1)

5 × 11 bits: μPD17147(A1)

5 × 12 bits: μPD17149(A1)

**Remark** CMOS or N-ch in ( ) indicate the output format of the port.

CMOS: CMOS push-pull output

N-ch : N-ch open-drain output

## CONTENTS

<b>1. PIN</b> .....	<b>9</b>
1.1. Pin Function .....	9
1.2. Equivalent Circuit of Pin .....	11
1.3. Handling of Unused Pins .....	15
1.4. Note on Using $\overline{\text{RESET}}$ and $\text{P0F}_0/\overline{\text{RLS}}$ Pins .....	16
<b>2. PROGRAM MEMORY (ROM)</b> .....	<b>17</b>
2.1 Configuration of Program Memory .....	17
<b>3. PROGRAM COUNTER (PC)</b> .....	<b>18</b>
3.1 Configuration of Program Counter .....	18
3.2 Operation of Program Counter .....	18
<b>4. STACK</b> .....	<b>19</b>
4.1 Configuration of Stack .....	19
4.2 Stack Function .....	19
<b>5. DATA MEMORY (RAM)</b> .....	<b>20</b>
5.1 Configuration of Data Memory .....	20
<b>6. GENERAL REGISTER (GR)</b> .....	<b>21</b>
6.1 General Register Pointer (RP) .....	21
<b>7. SYSTEM REGISTER (SYSREG)</b> .....	<b>22</b>
7.1 Configuration of System Register .....	22
<b>8. REGISTER FILE (RF)</b> .....	<b>24</b>
8.1 Configuration of Register File .....	24
8.2 Function of Register File .....	25
<b>9. DATA BUFFER (DBF)</b> .....	<b>26</b>
9.1 Configuration of Data Buffer .....	26
9.2 Function of Data Buffer .....	27
<b>10. ALU BLOCK</b> .....	<b>28</b>
10.1 Configuration of ALU Block .....	28
<b>11. PORTS</b> .....	<b>30</b>
11.1 Port 0A ( $\text{P0A}_0, \text{P0A}_1, \text{P0A}_2, \text{P0A}_3$ ) .....	30
11.2 Port 0B ( $\text{P0B}_0, \text{P0B}_1, \text{P0B}_2, \text{P0B}_3$ ) .....	31
11.3 Port 0C ( $\text{P0C}_0/\text{ADC}_0, \text{P0C}_1/\text{ADC}_1, \text{P0C}_2/\text{ADC}_2, \text{P0C}_3/\text{ADC}_3$ ) .....	32
11.4 Port 0D ( $\text{P0D}_0/\overline{\text{SCK}}, \text{P0D}_1/\text{SO}, \text{P0D}_2/\text{SI}, \text{P0D}_3/\overline{\text{TM1OUT}}$ ) .....	33
11.5 Port 0E ( $\text{P0E}_0, \text{P0E}_1, \text{P0E}_2, \text{P0E}_3$ ) .....	34
11.6 Port 0F ( $\text{P0F}_0/\overline{\text{RLS}}, \text{P0F}_1/\text{VREF}$ ) .....	34



<b>12. 8-BIT TIMERS/COUNTERS (TM0, TM1)</b> .....	<b>35</b>
12.1 Configuration of 8-Bit Timers/Counters .....	35
<b>13. BASIC INTERVAL TIMER (BTM)</b> .....	<b>39</b>
13.1 Configuration of Basic Interval Timer .....	39
13.2 Registers Controlling Basic Interval Timer .....	41
13.3 Watchdog Timer Function .....	43
<b>14. A/D CONVERTER</b> .....	<b>45</b>
14.1 Configuration of A/D Converter .....	45
14.2 Function of A/D Converter .....	46
14.3 Operation of A/D Converter .....	47
<b>15. SERIAL INTERFACE (SIO)</b> .....	<b>50</b>
15.1 Function of Serial Interface .....	50
15.2 Operation Mode of 3-Wire Serial Interface .....	52
<b>16. INTERRUPT FUNCTION</b> .....	<b>54</b>
16.1 Types of Interrupt Causes and Vector Addresses .....	54
16.2 Hardware of Interrupt Control Circuit .....	55
<b>17. STANDBY FUNCTION</b> .....	<b>56</b>
17.1 Outline of Standby Function .....	56
17.2 HALT Mode .....	58
17.3 STOP Mode .....	60
<b>18. RESET</b> .....	<b>63</b>
18.1 Reset Function .....	63
18.2 Reset Operation .....	64
<b>19. POC CIRCUIT (MASK OPTION)</b> .....	<b>65</b>
19.1 Function of POC Circuit .....	65
19.2 Conditions to Use POC Circuit .....	66
<b>20. INSTRUCTION SET</b> .....	<b>67</b>
20.1 Outline of Instruction Set .....	67
20.2 Legend .....	68
20.3 Instruction Set .....	69
20.4 Assembler (AS17K) Embedded Macro Instruction .....	71
<b>21. ASSEMBLER RESERVED WORDS</b> .....	<b>72</b>
21.1 Mask Option Directive .....	72
21.2 Reserved Symbols .....	74
<b>22. ELECTRICAL SPECIFICATIONS</b> .....	<b>82</b>
<b>23. CHARACTERISTIC CURVE (REFERENCE VALUE)</b> .....	<b>88</b>

**24. PACKAGE DRAWINGS ..... 90**

**25. RECOMMENDED SOLDERING CONDITIONS ..... 94**

**APPENDIX A. FUNCTION COMPARISON BETWEEN  $\mu$ PD17145 SUBSERIES AND  
THE  $\mu$ PD17135A AND 17137A ..... 96**

**APPENDIX B. DEVELOPMENT TOOLS ..... 98**

1. PIN

1.1. Pin Function

Pin Number	Symbol	Function	Output Format	After Reset
1	V <sub>DD</sub>	Power supply.	—	—
2	P0F <sub>1</sub> /V <sub>REF</sub>	Reference voltage input to port 0F and A/D converter. <ul style="list-style-type: none"> <li>• Pull-up resistor can be connected by mask option.</li> <li>• P0F<sub>1</sub></li> <li>• Bit 1 of 2-bit input port (P0F)</li> <li>• V<sub>REF</sub></li> <li>• Reference voltage input pin of A/D converter</li> </ul>	Input	Input (P0F <sub>1</sub> )
3 to 6	P0C <sub>3</sub> /ADC <sub>3</sub> to P0C <sub>0</sub> /ADC <sub>0</sub>	Analog input to port 0C and A/D converter. <ul style="list-style-type: none"> <li>• P0C<sub>3</sub>-P0C<sub>0</sub></li> <li>• 4-bit I/O port</li> <li>• Can be set in input or output mode bitwise.</li> <li>• ADC<sub>3</sub>-ADC<sub>0</sub></li> <li>• Analog inputs to A/D converter.</li> </ul>	CMOS push-pull	Input (P0C)
7 8 9 10	P0B <sub>3</sub> P0B <sub>2</sub> P0B <sub>1</sub> P0B <sub>0</sub>	Port 0B. <ul style="list-style-type: none"> <li>• 4-bit I/O port</li> <li>• Can be set in input or output mode in 4-bit units.</li> <li>• Pull-up resistor can be connected in 4-bit units via software.</li> </ul>	CMOS push-pull	Input
11 12 13 14	P0A <sub>3</sub> P0A <sub>2</sub> P0A <sub>1</sub> P0A <sub>0</sub>	Port 0A. <ul style="list-style-type: none"> <li>• 4-bit I/O port.</li> <li>• Can be set in input or output mode in 4-bit units.</li> <li>• Pull-up resistor can be connected in 4-bit units via software.</li> </ul>	CMOS push-pull	Input
15 16 17 18	P0E <sub>3</sub> P0E <sub>2</sub> P0E <sub>1</sub> P0E <sub>0</sub>	Port 0E. <ul style="list-style-type: none"> <li>• 4-bit I/O port.</li> <li>• Can be set in input or output mode in 4-bit units.</li> <li>• Pull-up resistor can be connected in 4-bit units via software.</li> </ul>	N-ch open-drain	Input
19  20 21 22	P0D <sub>3</sub> /TM1OUT  P0D <sub>2</sub> /SI P0D <sub>1</sub> /SO P0D <sub>0</sub> /SCK	Port 0D that is also used for timer 1 output, serial data input, serial data output, and serial clock I/O. <ul style="list-style-type: none"> <li>• Pull-up resistor can be connected bitwise via software.</li> <li>• P0D<sub>3</sub>-P0D<sub>0</sub></li> <li>• 4-bit I/O port.</li> <li>• Can be set in input or output mode bitwise.</li> <li>• TM1OUT</li> <li>• Timer 1 output</li> <li>• SI</li> <li>• Serial data input</li> <li>• SO</li> <li>• Serial data output</li> <li>• SCK</li> <li>• Serial clock I/O</li> </ul>	N-ch open-drain	Input (P0D)

Pin Number	Symbol	Function	Output Format	After Reset
23	P0F <sub>0</sub> / $\overline{\text{RLS}}$	Port 0F or standby mode release signal input. <ul style="list-style-type: none"> <li>• Pull-up resistor can be connected by mask option.</li> <li>• R0F<sub>0</sub></li> <li>• Bit 0 of 2-bit input port (P0F)</li> <li>• <math>\overline{\text{RLS}}</math></li> <li>• Standby mode release signal input</li> </ul>	Input	Input (P0F <sub>0</sub> )
24	INT	External interrupt request signal input. Also used to release standby mode. <ul style="list-style-type: none"> <li>• Pull-up resistor can be connected by mask option.</li> </ul>	Input	Input
25	$\overline{\text{RESET}}$	System reset input. <ul style="list-style-type: none"> <li>• Pull-up resistor can be connected by mask option.</li> </ul>	Input	Input
26 27	X <sub>OUT</sub> X <sub>IN</sub>	For system clock oscillation. Connect ceramic resonator across X <sub>IN</sub> and X <sub>OUT</sub> .	—	—
28	GND	GND	—	—

1.2 Equivalent Circuit of Pin

The input/output circuit of each pin is shown below, partially simplified.

(1) P0A<sub>0</sub> to P0A<sub>3</sub> and P0B<sub>0</sub> to P0B<sub>3</sub>

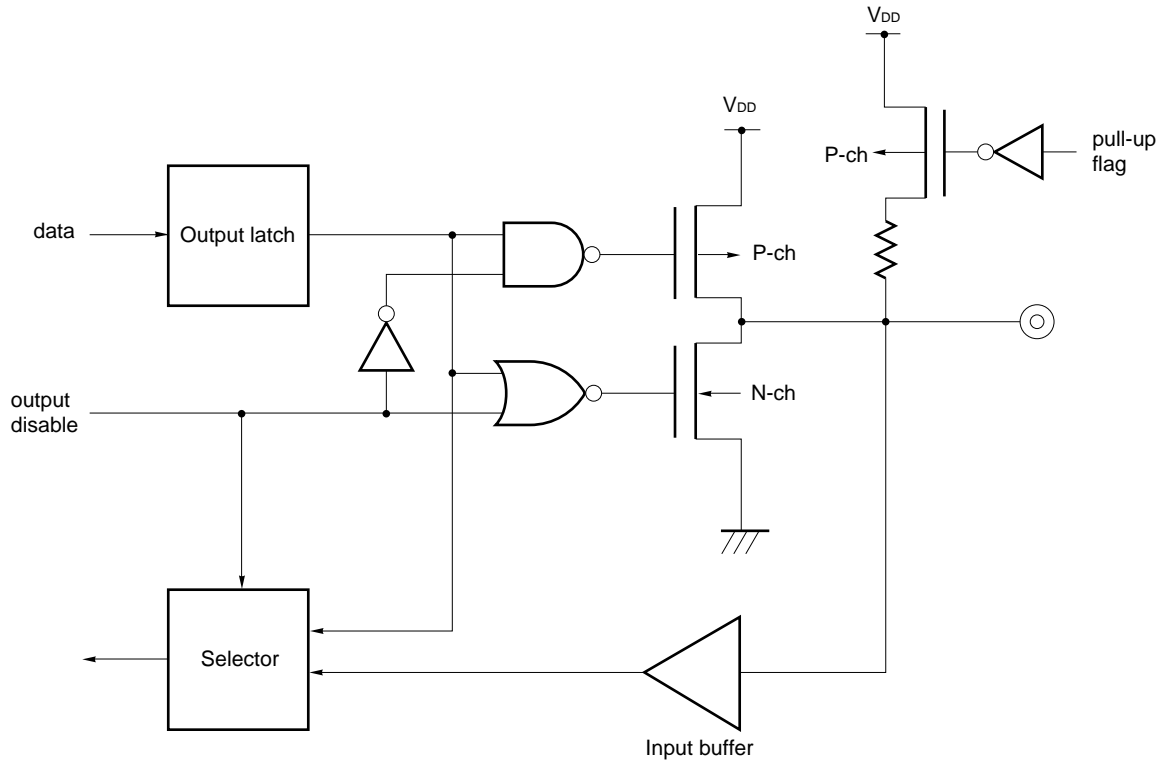

(2) P0C<sub>0</sub>/ADC<sub>0</sub> to P0C<sub>3</sub>/ADC<sub>3</sub>

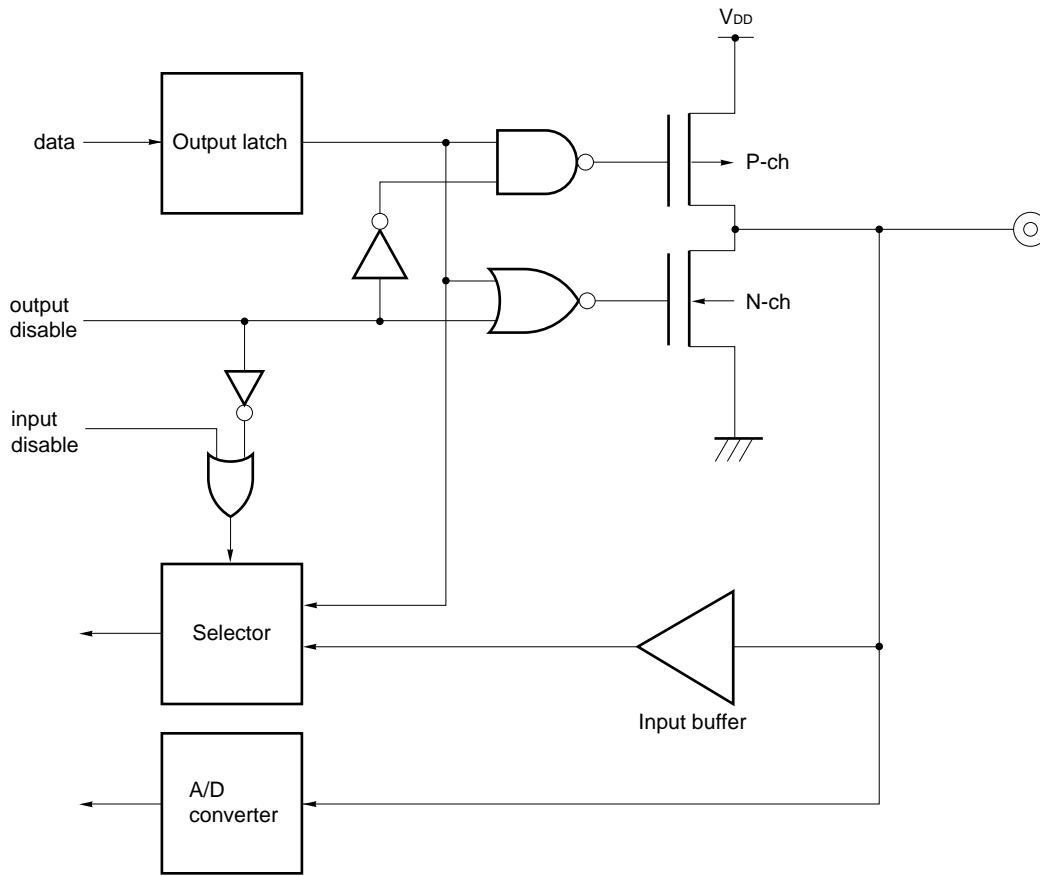

(3) P0D<sub>3</sub>/TM1OUT and P0D<sub>1</sub>/SO

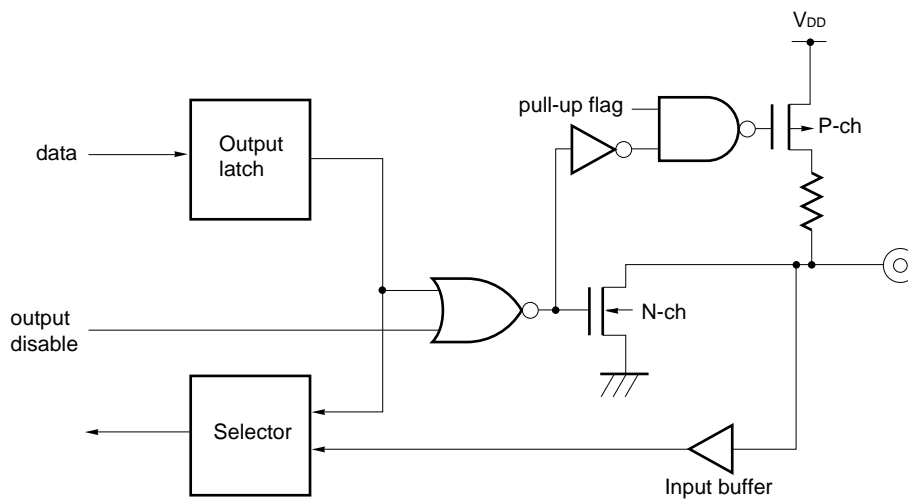

(4) P0D<sub>2</sub>/SI and P0D<sub>0</sub>/ $\overline{\text{SCK}}$

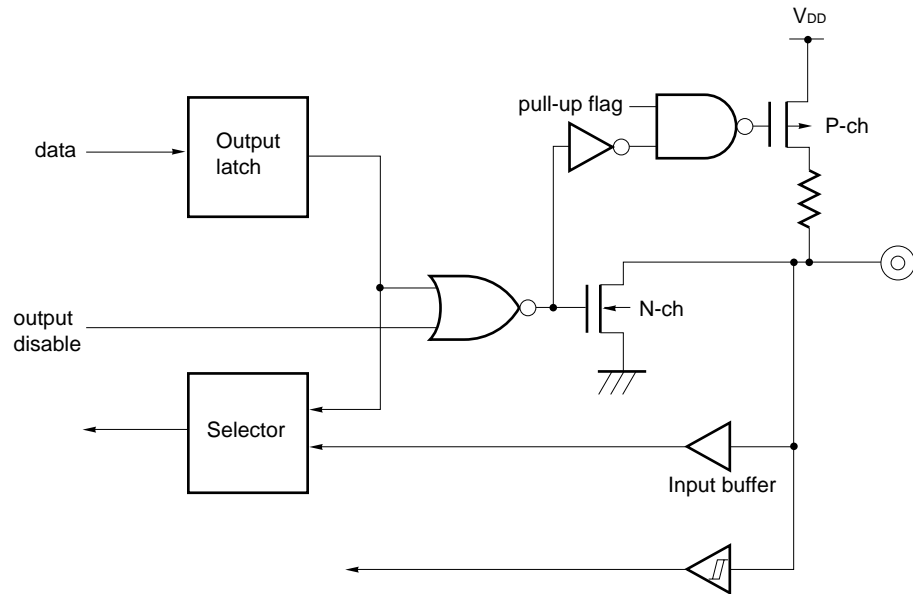

(5) P0E<sub>0</sub> to P0E<sub>3</sub>

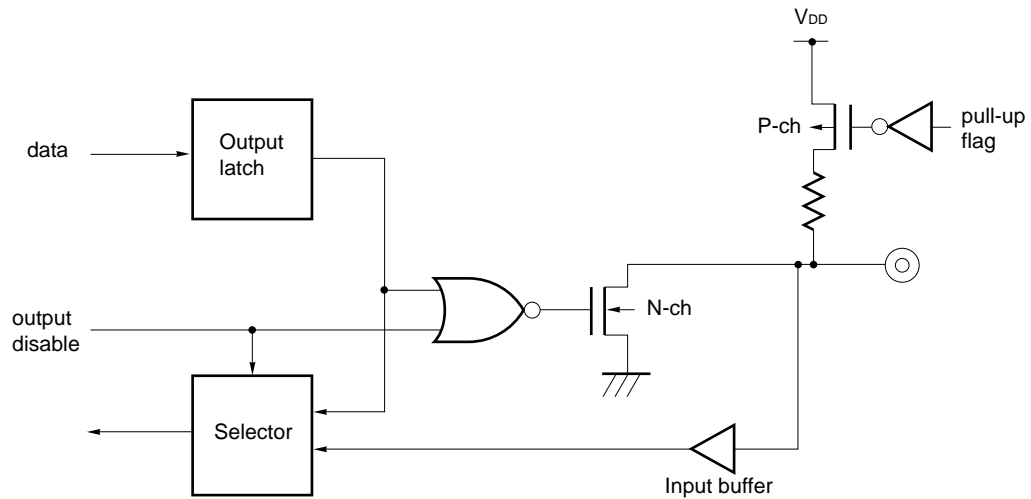

(6) P0F<sub>0</sub>/ $\overline{\text{RLS}}$

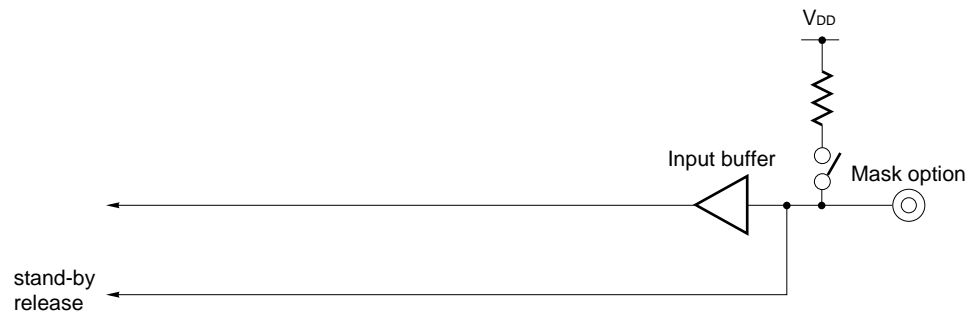

(7) POF<sub>1</sub>/V<sub>REF</sub>

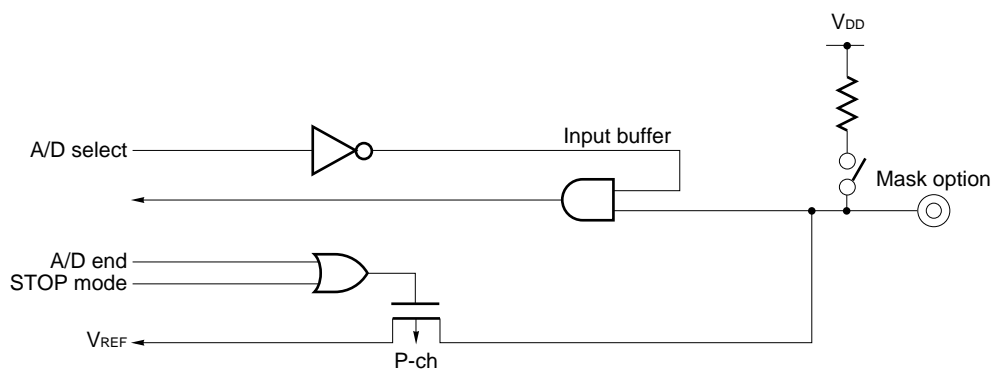

(8)  $\overline{\text{RESET}}$  and INT

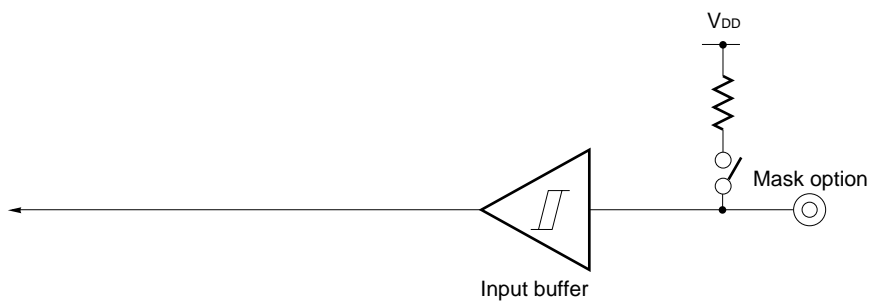



### 1.3 Handling of Unused Pins

Handle unused pins as shown in the table below.

**Table 1-1. Handling of Unused Pins**

Pin Name		Handling		
		Internally	Externally	
Port	Input mode	P0A, P0B, P0D, P0E	Connect on-chip pull-up resistor via software.	Open
		P0C	—	Connect to V <sub>DD</sub> via pull-up resistor, or to GND via pull-down resistor <sup>Note 1</sup> .
		P0F <sub>1</sub>	Do not connect on-chip pull-up resistor by mask option.	Directly connect to V <sub>DD</sub> or GND.
			Connect on-chip pull-up resistor by mask option.	Open
		P0F <sub>0</sub> <sup>Note 2</sup>	Do not connect on-chip pull-up resistor by mask option.	Directly connect to GND.
	Output mode	P0A, P0B, P0C (CMOS port)	—	Open
		P0D (N-ch open-drain port)	Output low level.	
		P0E (N-ch open-drain port)	Do not connect pull-up on-chip resistor via software, but output low level.	
	Connect on-chip pull-up resistor via software and output high level.			
	External interrupt (INT)		Do not connect on-chip pull-up resistor by mask option.	Directly connect to V <sub>DD</sub> or GND.
Connect on-chip pull-up resistor by mask option.			Open	
$\overline{\text{RESET}}$ <sup>Note 3</sup> (when only internal POC circuit is used)		Do not connect on-chip pull-up resistor by mask option.	Directly connect to V <sub>DD</sub> .	
		Connect on chip pull-up resistor by mask option.		

- Notes 1.** Take into consideration the drive capability and current dissipation of a port when the port is externally pulled up or down. To pull up or down the port with a high resistance, exercise care so that noise is not superimposed on the port pin. The appropriate value of the pull-up or pull-down resistor differs depending on the application circuit. Generally, select a resistor of several 10 kΩ.
- 2.** The P0F<sub>0</sub>/RLS pin is also used to set a test mode. When this pin is not used, do not connect a pull-up resistor to it by mask option, but directly connect it to GND.
- 3.** In an application circuit where a high reliability is required, be sure to input the  $\overline{\text{RESET}}$  signal from an external source. The  $\overline{\text{RESET}}$  pin is also used to set a test mode. When this pin is not used, directly connect it to V<sub>DD</sub>.

**Caution** It is recommended to fix the input/output mode, pull-up resistor by software, and the output level of the pin by repeatedly setting them in each loop of the program.

**1.4 Note on Using  $\overline{\text{RESET}}$  and  $\text{P0F}_0/\overline{\text{RLS}}$  Pins**

The  $\overline{\text{RESET}}$  and  $\text{P0F}_0/\overline{\text{RLS}}$  pins also have a function to set a test mode in which the internal operation of the  $\mu$ PD17149(A1) is tested (for IC test only), in addition to the function described in **1.1 Pin Function**.

If a voltage higher than  $V_{DD}$  is applied to these pins, the test mode is set. If a noise higher than  $V_{DD}$  is superimposed on these pins during normal operation, therefore, the test mode is set by mistake, affecting normal operation.

If the wiring length of the  $\overline{\text{RESET}}$  or  $\text{P0F}_0/\overline{\text{RLS}}$  pin is too long, for example, noise may be superimposed on the pin.

To prevent this, the wiring length must be kept as short as possible. Otherwise, use a diode or capacitor as shown below.

- **Connect a low- $V_F$  diode between  $V_{DD}$  and  $\overline{\text{RESET}}$ ,  $\text{P0F}_0/\overline{\text{RLS}}$**

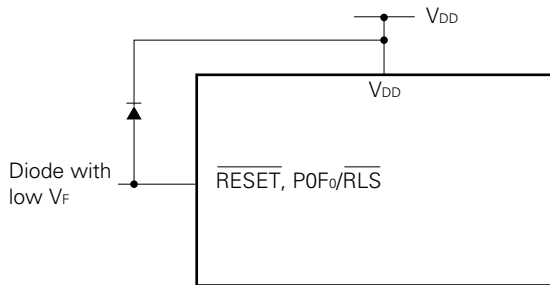

- **Connect a capacitor between  $V_{DD}$  and  $\overline{\text{RESET}}$ ,  $\text{P0F}_0/\overline{\text{RLS}}$**

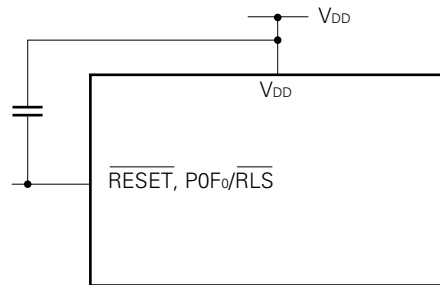

## 2. PROGRAM MEMORY (ROM)

Table 2-1 shows the program memory configuration of the μPD17145(A1), 17147(A1), and 17149(A1).

**Table 2-1. Program Memory Configuration**

Part Number	Program Memory Capacity	Program Memory Address
μPD17145(A1)	2 KB (1024 × 16 bits)	0000H-03FFH
μPD17147(A1)	4 KB (2048 × 16 bits)	0000H-07FFH
μPD17149(A1)	8 KB (4096 × 16 bits)	0000H-0FFFH

The program memory stores programs and constant data tables.

The program memory is addressed by the program counter.

Addresses 0000H-0005H are allocated to a reset start address and various interrupt vector addresses.

### 2.1 Configuration of Program Memory

Figure 2-1 shows the program memory map. The program memory is divided in units called “pages” each of which consists of 2K steps with one step made up of 16 bits.

Addresses 0000H-07FFH (page 0) of the program memory can be specified by the direct subroutine call instruction. The entire address range of the program memory, 0000H-0FFFH, can be specified by the branch, indirect subroutine call, and table reference instructions.

**Figure 2-1. Program Memory Map**

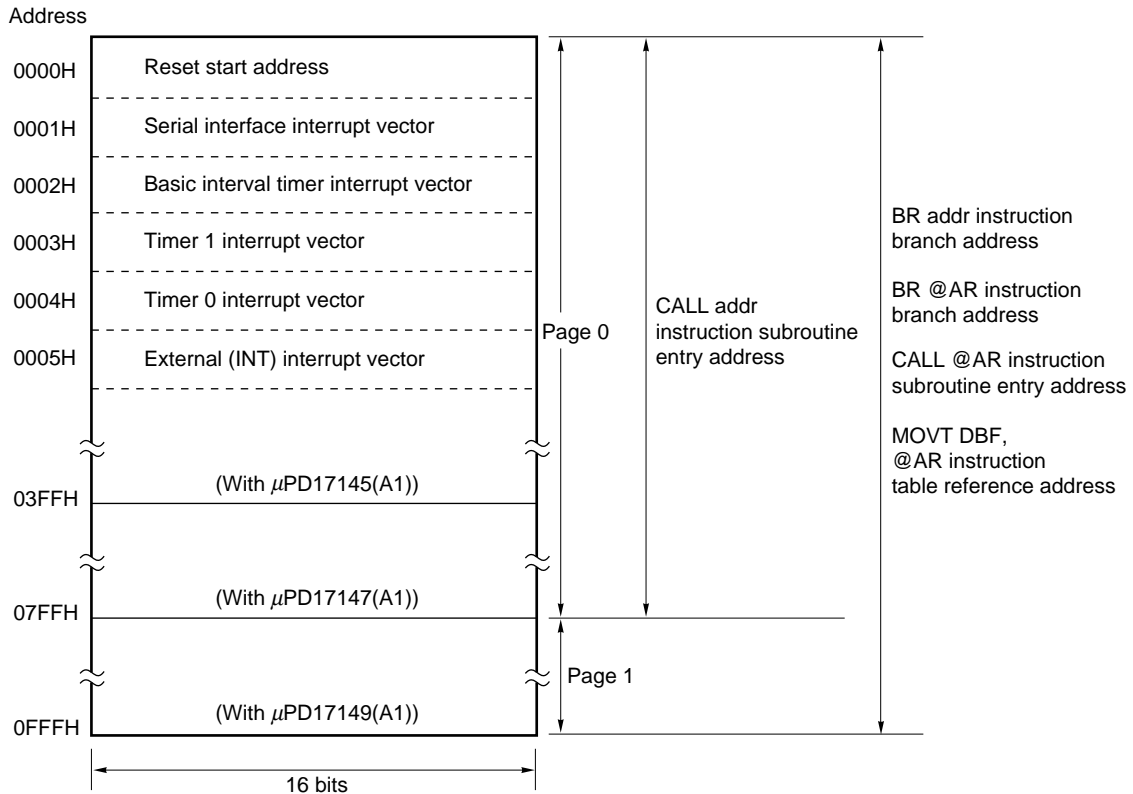

### 3. PROGRAM COUNTER (PC)

The program counter is used to address the program memory.

#### 3.1 Configuration of Program Counter

The program counter is a 10-/11-/12-bit binary counter as shown in Figure 3-1.

Figure 3-1. Program Counter

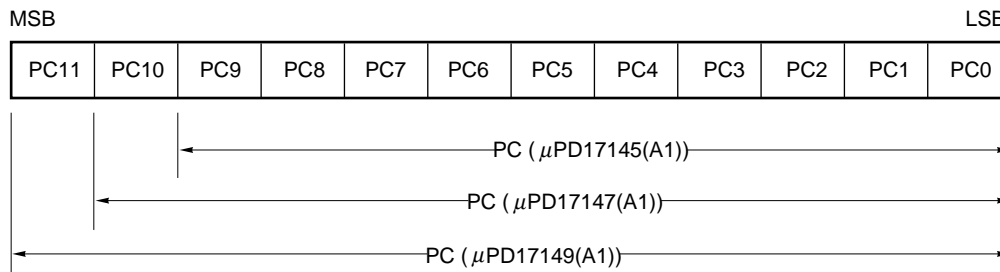

#### 3.2 Operation of Program Counter

Usually, the contents of the program counter are automatically incremented each time an instruction has been executed. When reset has been effected, when a branch, subroutine call, return, or table reference instruction has been executed, or when an interrupt has been acknowledged, the address of the program memory to be executed next is set to the program counter.

Figure 3-2. Value of Program Counter after Instruction Execution

Instruction	Value of Program Counter											
	PC11	PC10	PC9	PC8	PC7	PC6	PC5	PC4	PC3	PC2	PC1	PC0
At reset	0	0	0	0	0	0	0	0	0	0	0	0
BR addr	0	Value specified by addr										
	1											
CALL addr	0											
BR @AR CALL @AR (MOVT DBF, @AR)	Contents of address register (AR)											
RET RETSK RETI	Contents of address stack indicated by stack pointer (return address)											
When interrupt is acknowledged	Vector address of each interrupt											

**Remark** The μPD17145(A1) does not have PC11 and PC10. The μPD17147(A1) does not have PC11.

## 4. STACK

The stack is a register to which the return address of the program or the contents of the system registers, which are described later, are saved when a subroutine call instruction is executed or when an interrupt is acknowledged.

### 4.1 Configuration of Stack

Figure 4-1 shows the configuration of the stack.

The stack consists of a 3-bit binary counter, stack pointer (SP), five 10-bit (μPD17145(A1)), 11-bit (μPD17147(A1)), or 12-bit (μPD17149(A1)) address stack registers (ASRs), and three 5-bit interrupt stack registers (INTSKs).

Figure 4-1. Configuration of Stack

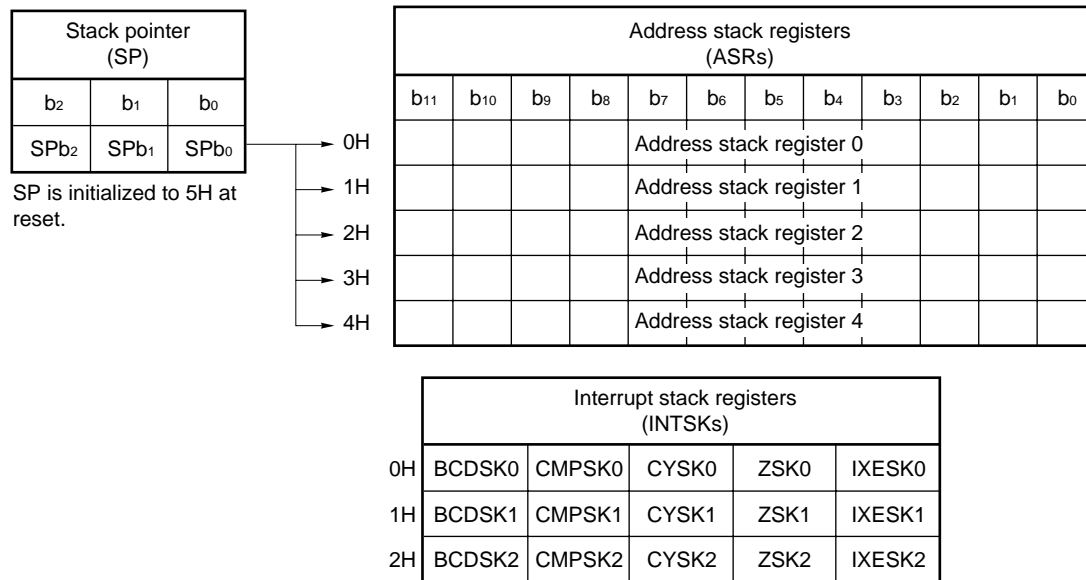

### 4.2 Stack Function

The stack is used to save a return address when the subroutine call or table reference instruction is executed. When an interrupt is acknowledged, the return address of the program and the contents of the program status word (PSWORD) are automatically saved to the stack. After they are saved to the stack, all the bits of PSWORD are cleared to 0.

### 5. DATA MEMORY (RAM)

The data memory is used to store data for operation and control. Data can always be written to or read from this memory by using an instruction.

#### 5.1 Configuration of Data Memory

The data memory is assigned addresses each consisting of 7 bits. The higher 3 bits of an address are called a “row address”, while the lower 4 bits are called a “column address”.

Take address 1AH for example. The row address of this address is 1H and the column address is 0AH. One address consists of 4 bits (= 1 nibble) of memory.

The data memory consists of an area to which the user can save data, and areas to which special functions are allocated in advance. These areas are:

- System register (SYSREG) (Refer to 7. SYSTEM REGISTER (SYSREG).)
- Data buffer (DBF) (Refer to 9. DATA BUFFER (DBF).)
- Port register (Refer to 11. PORT.)

Figure 5-1. Configuration of Data Memory

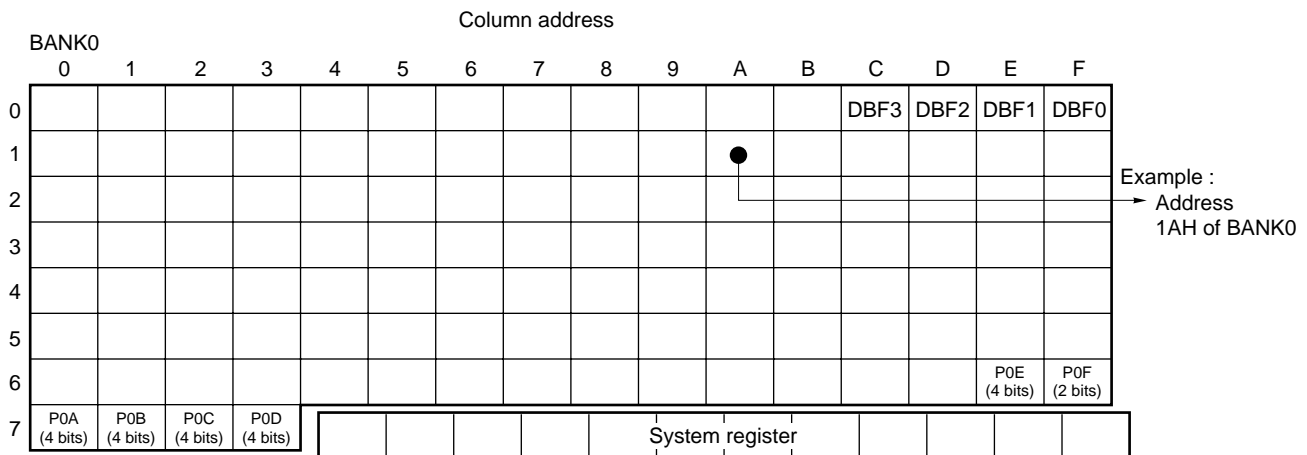

## 6. GENERAL REGISTER (GR)

As its name implies, the general register is used for general purposes such as data transfer and operation.

The general register of the 17K series is not a fixed area, but an area specified on the data memory by using the general register pointer (RP). Therefore, a part of the data memory area can be specified as a general register as necessary, so that data can be transferred between data memory areas and the data in the data memory can be operated with a single instruction.

### 6.1 General Register Pointer (RP)

RP is a pointer that specifies part of the data memory as the general register. RP specifies the bank and row addresses of a data memory area that is to be specified as the general register. Consisting of a total of 7 bits, RP is assigned to 7DH (RPH) and 7EH (RPL), and the higher 3 bits of the system register (refer to 7. SYSTEM REGISTER (SYSREG)).

RPH specifies a bank, and RPL specifies a data memory row address.

Figure 6-1. Configuration of General Register Pointer

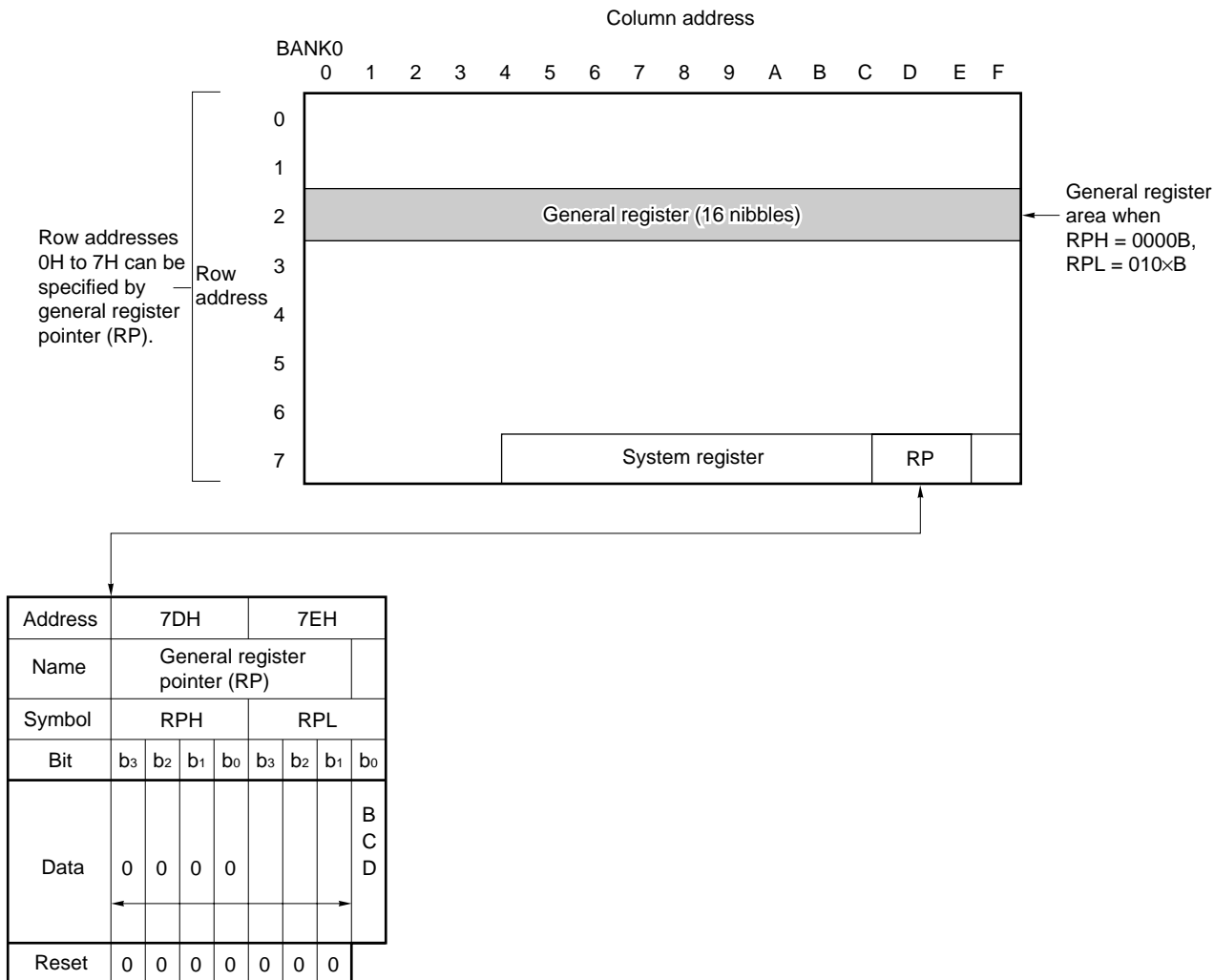

## 7. SYSTEM REGISTER (SYSREG)

The system register (SYSREG) is a register that directly controls the CPU, and is located on the data memory.

### 7.1 Configuration of System Register

Figure 7-1 shows the location of the system register on the data memory. As shown in this figure, the system register is located at addresses 74H-7FH of the data memory.

Because the system register is located on the data memory, it can be manipulated by all the data memory manipulation instructions. It is therefore possible to specify the system register as a general register.

**Figure 7-1. Location of System Register on Data Memory**

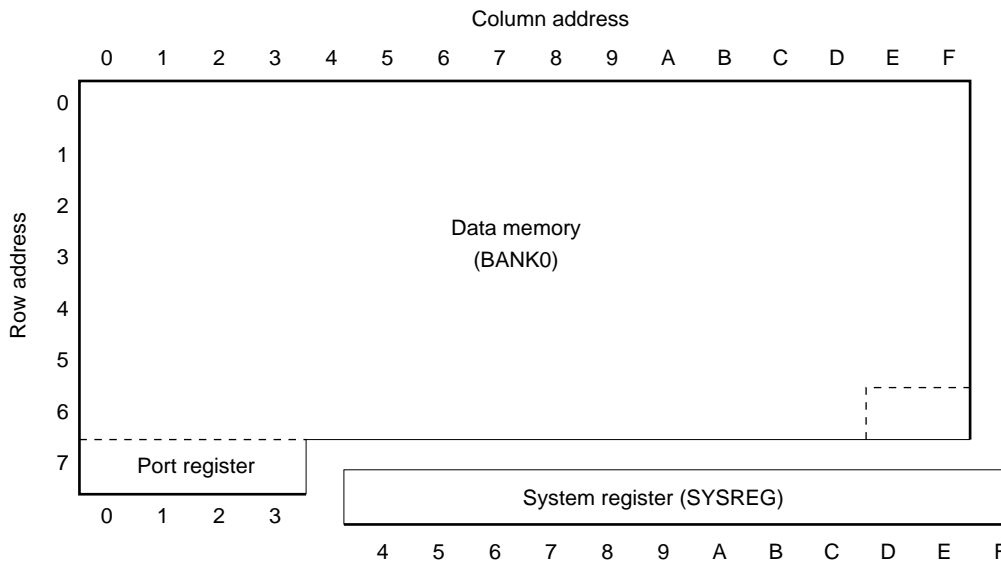

Figure 7-2 shows the configuration of the system register. As shown in this figure, the system register consists of the following seven registers:

- Address register (AR)
- Window register (WR)
- Bank register (BANK)
- Index register (IX)
- Data memory row address pointer (MP)
- General register pointer (RP)
- Program status word (PSWORD)



Figure 7-2. Configuration of System Register

Address	74H	75H	76H	77H	78H	79H	7AH	7BH	7CH	7DH	7EH	7FH
Name	Address register (AR)				Window register (WR)	Bank register (BANK)	Index register (IX) Data memory row address pointer (MP)			General register pointer (RP)		Program status word (PSWORD)
Symbol	AR3	AR2	AR1	AR0	WR	BANK	IXH MPH	IXM MPL	IXL	RPH	RPL	PSW
Bit	b <sub>3</sub> b <sub>2</sub> b <sub>1</sub> b <sub>0</sub>	b <sub>3</sub> b <sub>2</sub> b <sub>1</sub> b <sub>0</sub>	b <sub>3</sub> b <sub>2</sub> b <sub>1</sub> b <sub>0</sub>	b <sub>3</sub> b <sub>2</sub> b <sub>1</sub> b <sub>0</sub>	b <sub>3</sub> b <sub>2</sub> b <sub>1</sub> b <sub>0</sub>	b <sub>3</sub> b <sub>2</sub> b <sub>1</sub> b <sub>0</sub>	b <sub>3</sub> b <sub>2</sub> b <sub>1</sub> b <sub>0</sub>	b <sub>3</sub> b <sub>2</sub> b <sub>1</sub> b <sub>0</sub>	b <sub>3</sub> b <sub>2</sub> b <sub>1</sub> b <sub>0</sub>	b <sub>3</sub> b <sub>2</sub> b <sub>1</sub> b <sub>0</sub>	b <sub>3</sub> b <sub>2</sub> b <sub>1</sub> b <sub>0</sub>	b <sub>3</sub> b <sub>2</sub> b <sub>1</sub> b <sub>0</sub>
Data <sup>Note1</sup>	0 0 0 0	0 0 0 0	0 0 0 0	0 0 0 0	0 0 0 0	0 0 0 0	0 0 0 0	0 0 0 0	0 0 0 0	0 0 0 0	0 0 0 0	B C C I C M Y Z D P X E
Initial value at reset	0 0 0 0	0 0 0 0	0 0 0 0	0 0 0 0	0 0 0 0	0 0 0 0	0 0 0 0	0 0 0 0	0 0 0 0	0 0 0 0	0 0 0 0	0 0 0 0

- Notes**
- 0 in this field means that the bit is "fixed to 0".
  - b<sub>3</sub> and b<sub>2</sub> of AR2 of the μPD17145(A1) are fixed to 0. b<sub>3</sub> of AR2 of the μPD17147(A1) is fixed to 0.

**8. REGISTER FILE (RF)**

The register file is a register that mainly sets the conditions of the peripheral hardware.

**8.1 Configuration of Register File**

**8.1.1 Configuration of register file**

Figure 8-1 shows the configuration of the register file.

As shown in this figure, the register file consists of 128 nibbles (128 × 4 bits). Like the data memory, the register file is assigned addresses in 4-bit units, with row addresses 0H-7H and column addresses 0H-0FH.

Addresses 00H-3FH of the register file are called a control register.

**Figure 8-1. Configuration of Register File**

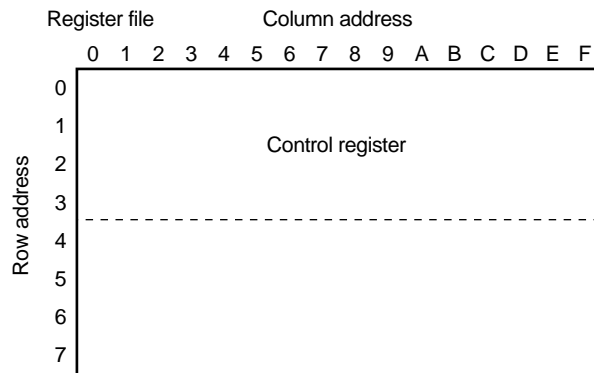

**8.1.2 Register file and data memory**

Figure 8-2 shows the relationships between the register file and data memory.

As shown in this figure, addresses 40H to 7FH of the register file overlaps the data memory.

It seems from the program as if addresses 40H to 7FH of the data memory exist at addresses 40H-7FH of the register file.

Figure 8-2. Relationships between Register File and Data Memory

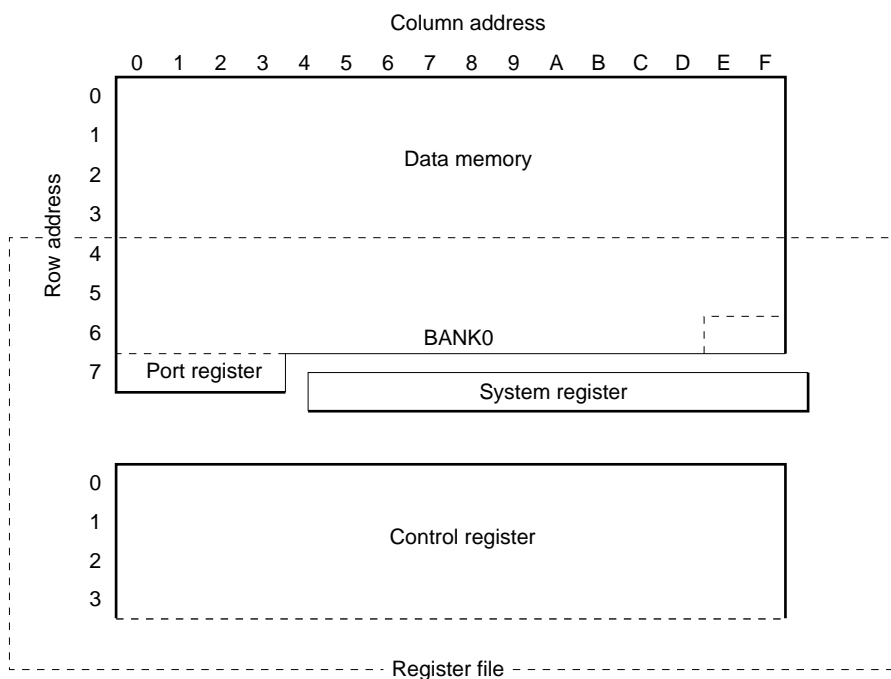

## 8.2 Function of Register File

### 8.2.1 Function of register file

The register file is a collection of registers that set the conditions of the peripheral hardware by using the PEEK or POKE instruction.

The registers that control the peripheral hardware are allocated to addresses 00H-3FH. These registers are called control registers.

Addresses 40H-7FH of the register file overlap the ordinary data memory. These addresses can therefore be read or written by not only the MOV instruction but also the PEEK and POKE instructions.

### 8.2.2 Functions of control registers

The control registers are used to set the conditions of the peripheral hardware listed below.

For the details of the peripheral hardware and control registers, refer to the description of each peripheral hardware.

- Port
- 8-bit timers/counters (TM0, TM1)
- Basic interval timer (BTM)
- A/D converter
- Serial interface (SIO)
- Interrupt function
- Stack pointer (SP)

### 9. DATA BUFFER (DBF)

The data buffer consists of 4 nibbles allocated to addresses 0CH-0FH of BANK0 of the data memory.

This area is a data storage area that transfers data with the peripheral hardware of the CPU (address register, serial interface, timers 0 and 1, and A/D converter) by using the GET or PUT instruction. Moreover, the constants on the program memory can be read to the data buffer by using the MOVT DBF, @AR instruction.

#### 9.1 Configuration of Data Buffer

Figure 9-1 shows the location of the data buffer on the data memory.

As shown in this figure, the data buffer is allocated addresses 0CH-0FH of the data memory, and consists of a total of 16 bits or 4 nibbles (4 × 4 bits).

Figure 9-1. Location of Data Buffer

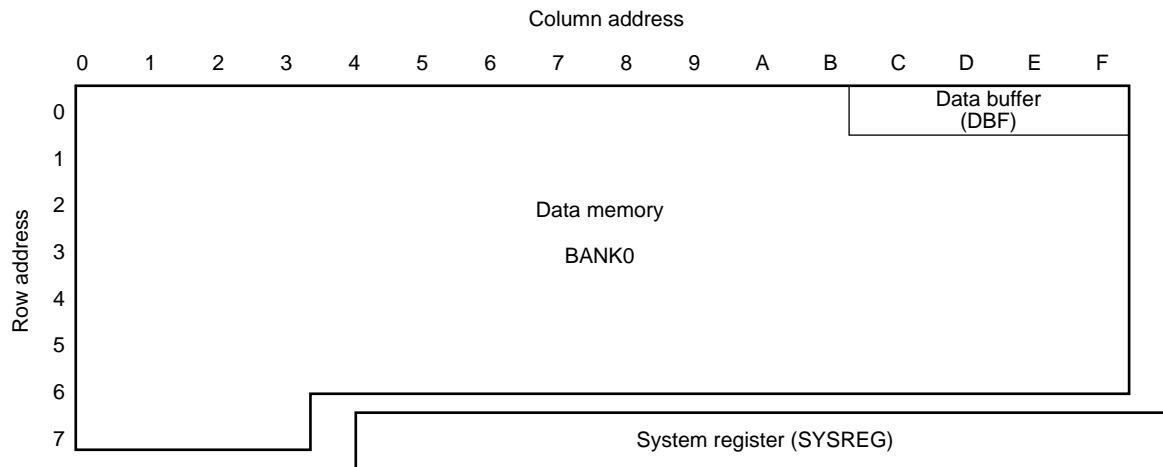

Figure 9-2 shows the configuration of the data buffer. As shown in this figure, the data buffer consists of 16 bits of the data memory, with the bit 0 of address 0FH as the LSB and bit 3 of address 0CH as the MSB.

Figure 9-2. Configuration of Data Buffer

Data memory BANK0	Address	0CH				0DH				0EH				0FH			
	Bit	b <sub>3</sub>	b <sub>2</sub>	b <sub>1</sub>	b <sub>0</sub>	b <sub>3</sub>	b <sub>2</sub>	b <sub>1</sub>	b <sub>0</sub>	b <sub>3</sub>	b <sub>2</sub>	b <sub>1</sub>	b <sub>0</sub>	b <sub>3</sub>	b <sub>2</sub>	b <sub>1</sub>	b <sub>0</sub>
Data buffer	Bit	b <sub>15</sub>	b <sub>14</sub>	b <sub>13</sub>	b <sub>12</sub>	b <sub>11</sub>	b <sub>10</sub>	b <sub>9</sub>	b <sub>8</sub>	b <sub>7</sub>	b <sub>6</sub>	b <sub>5</sub>	b <sub>4</sub>	b <sub>3</sub>	b <sub>2</sub>	b <sub>1</sub>	b <sub>0</sub>
	Symbol	DBF3				DBF2				DBF1				DBF0			
	Data	^ M S B v ←				Data				^ L S B v →							

Because the data buffer is located on the data memory, it can be manipulated by all the data memory manipulation instructions.

### 9.2 Function of Data Buffer

The data buffer has two main functions.

One is to transfer data with the peripheral hardware, and the other is to read the constant data on the program memory (table reference). Figure 9-3 shows the relationships between the data buffer and peripheral hardware.

**Figure 9-3. Data Buffer and Peripheral Hardware**

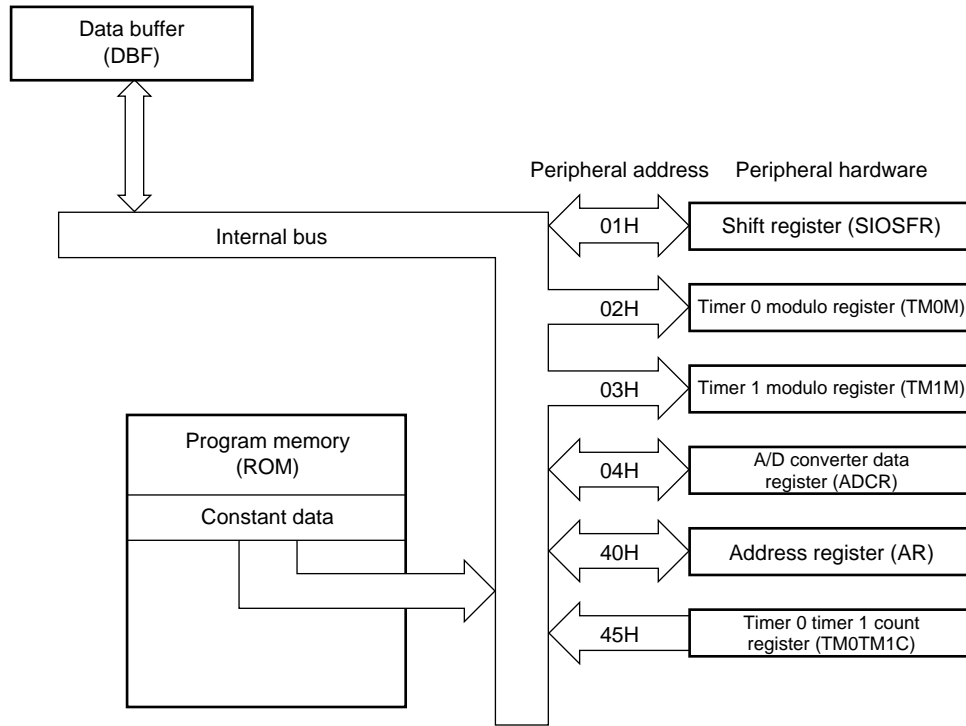

## 10. ALU BLOCK

The ALU executes arithmetic and logical operations, bit judgment, and rotation processing of 4-bit data.

### 10.1 Configuration of ALU Block

Figure 10-1 shows the configuration of the ALU block.

As shown, the ALU block consists of an ALU that processes 4-bit data, and peripheral circuits such as temporary registers A and B, status flip-flops that control the status of the ALU, and a decimal adjustment circuit that is used when a BCD operation is performed.

The status flip-flops are a zero flag FF, carry flag FF, compare flag FF, and BCD flag FF, as shown in Figure 10-1.

The status flip-flops correspond to the zero flag (Z), carry flag (CY), compare flag (CMP), and BCD flag (BCD) of the program status word (PSWORD: addresses 7EH, 7FH) on a one-to-one basis.

Figure 10-1. Configuration of ALU Block

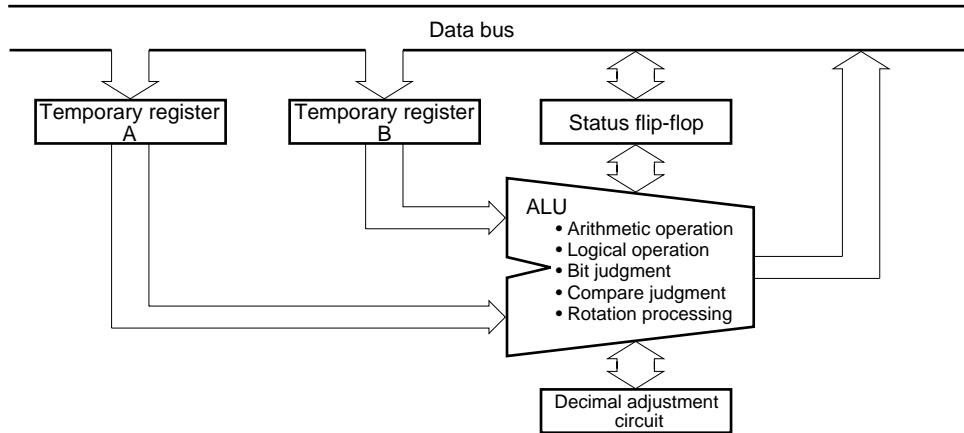

Address	7EH	7FH			
Name	Program status word (PSWORD)				
Bit	b <sub>0</sub>	b <sub>3</sub>	b <sub>2</sub>	b <sub>1</sub>	b <sub>0</sub>
Flag	BCD	CMP	CY	Z	IXE

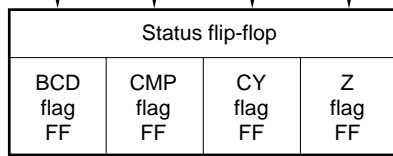

Functional Outline	
→	Indicates that result of arithmetic operation is 0.
→	Stores carry or borrow resulting from arithmetic operation.
→	Specifies whether result of arithmetic operation is stored.
→	Specifies whether decimal adjustment is performed when arithmetic operation is executed.

11. PORTS

11.1 Port 0A (P0A0, P0A1, P0A2, P0A3)

Port 0A is a 4-bit I/O port with an output latch. It is mapped at address 70H of BANK0 of the data memory. The output format is CMOS push-pull output.

This port can be set in the input or output mode in 4-bit units. The input or output mode is specified by P0AGIO (bit 0 of address 2CH) on the register file.

When P0AGIO = 0, all the pins of port 0A are set in the input mode. When an instruction that reads the data of the port register is executed at this time, the pin status is read.

When P0AGIO = 1, all the pins of port 0A are set in the output mode, and the contents written to the output latch are output to the pins. When an instruction that reads the port status is executed with the port set in the output mode, the contents of the output latch, instead of the pin status, are read.

A pull-up resistor can be connected on-chip to this port through software. Whether the pull-up resistor is connected is specified by P0AGPU (bit 0 at address 0CH) of the register file. All the four pins are pulled up when P0AGPU = 1. When P0AGPU = 0, the pull-up resistor is not connected.

P0AGIO and P0AGPU are cleared to “0” at reset, and all the P0A pins are set in the input mode without the pull-up resistor connected. The value of the output latch is also cleared to “0”.

**Table 11-1. Writing and Reading Port Register (0.70H)**

P0AGIO RF: 2CH, bit 0	Input/Output Mode of Pin	BANK0 70H	
		Write	Read
0	Input	Enabled	P0A pin status
1	Output	Write to P0A latch	P0A latch contents



**11.2 Port 0B (P0B0, P0B1, P0B2, P0B3)**

Port 0B is a 4-bit I/O port with an output latch. It is mapped at address 71H of BANK0 of the data memory. The output format is CMOS push-pull output.

This port can be set in the input or output mode in 4-bit units. The input or output mode is specified by P0BGIO (bit 1 of address 2CH) on the register file.

When P0BGIO = 0, all the pins of port 0B are set in the input mode. When an instruction that reads the data of the port register is executed at this time, the pin status is read.

When P0BGIO = 1, all the pins of port 0B are set in the output mode, and the contents written to the output latch are output to the pins. When an instruction that reads the port status is executed with the port set in the output mode, the contents of the output latch, instead of the pin status, are read.

A pull-up resistor can be connected on-chip to this port through software. Whether the pull-up resistor is connected is specified by P0BGPU (bit 1 at address 0CH) of the register file. All the four-bit pins are pulled up when P0BGPU = 1. When P0BGPU = 0, the pull-up resistor is not connected.

P0BGIO and P0BGPU are cleared to “0” at reset, and all the P0B pins are set in the input mode without the pull-up resistor connected. The value of the output latch is also cleared to “0”.

**Table 11-2. Writing and Reading Port Register (0.71H)**

P0BGIO RF: 2CH, bit 1	Input/Output Mode of Pin	BANK0 71H	
		Write	Read
0	Input	Enabled	P0B pin status
1	Output	Write to P0B latch	P0B latch contents

### 11.3 Port 0C (P0C0/ADC0, P0C1/ADC1, P0C2/ADC2, P0C3/ADC3)

Port 0C is a 4-bit I/O port with an output latch. It is mapped at address 72H of BANK0 of the data memory. The output format is CMOS push-pull output.

This port can be set in the input or output mode in 1-bit units. The input or output mode is specified by P0CBIO0-P0CBIO3 (address 1CH) on the register file.

When P0CBIO<sub>n</sub> = 0 (n = 0 to 3), the corresponding port pin, P0C<sub>n</sub>, is set in the input mode. When an instruction that reads the data of the port register is executed at this time, the pin status is read. When P0CBIO<sub>n</sub> = 1 (n = 0 to 3), the P0C<sub>n</sub> pin is set in the output mode, and the contents written to the output latch are output to the pin. When an instruction that reads the port status is executed with a port pin set in the output mode, the contents of the output latch, instead of the pin status, are read.

At reset, P0CBIO0-P0CBIO3 are cleared to “0”, setting all the P0C pins in the input mode. The contents of the output latch are also cleared to “0” at this time.

Port 0C is also used to input analog voltages to the A/D converter. Whether each pin of the port is used as a port pin or analog input pin is specified by P0C0IDI-P0C3IDI (address 1BH) on the register file.

When P0C<sub>n</sub>IDI = 0 (n = 0-3), the P0C<sub>n</sub>/ADC<sub>n</sub> pin functions as a port pin. When P0C<sub>n</sub>IDI = 1 (n = 0 to 3), the P0C<sub>n</sub>/ADC<sub>n</sub> pin functions as an analog input pin of the A/D converter. If any of the P0C<sub>n</sub>IDI (n = 0 to 3) bits is set to “1”, the P0F1/V<sub>REF</sub> pin is used as the V<sub>REF</sub> pin.

When a pin of port 0C is used as an analog input pin of the A/D converter, set the P0C<sub>n</sub>IDI corresponding to the pin to which an analog voltage is applied to 1, to disable the port input function. Moreover, clear P0CBIO<sub>n</sub> (n = 0-3) to 0 to set the input port mode. The pin used as an analog input pin is selected by ADCCH0 and ADCCH1 (bits 1 and 0 of address 22H) on the register file.

At reset, P0CBIO0-P0CBIO3, P0C0IDI-P0C3IDI, ADCCH0, and ADCCH1 are cleared to 0, setting the input port mode.

**Table 11-3. Selecting Port or A/D Converter Mode**

(n = 0 to 3)

P0C <sub>n</sub> IDI RF:1BH	P0CBIO <sub>n</sub> RF:1CH	Function	BANK0 72H	
			Write	Read
0	0	Input port	Enabled. P0C latch	Pin status
	1	Port output	Enabled. P0C latch	Contents of P0C latch
1	0	Analog input of A/D <sup>Note 1</sup>	Enabled. P0C latch	Contents of P0C latch
	1	Output port and analog input of A/D <sup>Note 2</sup>	Enabled. P0C latch	Contents of P0C latch

- Notes**
1. Normal setting when the P0C pins are used as the analog input pins of the A/D converter.
  2. The P0C pins function as output port pins. At this time, the analog input voltages change with the output from the port. To use the pins as analog input pins, be sure to clear P0CBIO<sub>n</sub> to 0.

**11.4 Port 0D (P0D0/ $\overline{\text{SCK}}$ , P0D1/SO, P0D2/SI, P0D3/ $\overline{\text{TM1OUT}}$ )**

Port 0D is a 4-bit I/O port with an output latch. It is mapped at address 73H of BANK0 of the data memory. The output format is N-ch open-drain output.

This port can be set in the input or output mode in 1-bit units. The input or output mode is specified by P0DBIO0-P0DBIO3 (address 2BH) on the register file.

When P0DBIO<sub>n</sub> = 0 (n = 0 to 3), the corresponding port pin, P0D<sub>n</sub>, is set in the input mode. When an instruction that reads the data of the port register is executed at this time, the pin status is read. When P0DBIO<sub>n</sub> = 1, the P0D<sub>n</sub> pin is set in the output mode, and the contents written to the output latch are output to the pin. When an instruction that reads the port status is executed with a port pin set in the output mode, the contents of the output latch, instead of the pin status, are read.

A pull-up resistor can be connected on-chip to this port through software. Whether the pull-up resistor is connected or not is specified bitwise by using P0DBPU0-P0DBPU3 (address 0DH) on the register file. When P0DBPU<sub>n</sub> = 1, the P0D<sub>n</sub> pin is pulled up. When P0DBPU<sub>n</sub> = 0, the pull-up resistor is not connected.

At reset, P0DBIO<sub>n</sub> is cleared to "0", setting all the P0D pins in the input mode. The contents of the output latch are also cleared to "0" at this time. Note that the contents of the output latch are not changed even if the status of P0DBIO<sub>n</sub> is changed from "1" to "0".

Port 0D is also used as serial interface input/output and timer 1 output pins. Whether the P0D<sub>0</sub> to P0D<sub>2</sub> pins are used as port pins or serial interface I/O pins ( $\overline{\text{SCK}}$ , SO, and SI) is specified by SIOEN (bit 0 of 0BH) on the register file. Whether the P0D<sub>3</sub> pin is used as a port pin or timer 1 output ( $\overline{\text{TM1OUT}}$ ) pin is specified by TM1OSEL (bit 3 of 0BH) on the register file. If TM1OSEL = 1, "1" is output when timer 1 is reset, and the output is inverted each time the count value of timer 1 coincides with the contents of the modulo register.

**Table 11-4. Contents of Register File and Pin Function**

(n = 0 to 3)

Value of Register File			Pin Function			
TM1OSEL RF: 0BH Bit 3	SIOEN RF: 0BH Bit 0	P0DBIO <sub>n</sub> RF: 2BH Bit n	P0D <sub>0</sub> / $\overline{\text{SCK}}$	P0D <sub>1</sub> /SO	P0D <sub>2</sub> /SI	P0D <sub>3</sub> / $\overline{\text{TM1OUT}}$
0	0	0	Input port			
		1	Output port			
	1	0	$\overline{\text{SCK}}$	SO	SI	Input port
		1				Output port
1	0	0	Input port			
		1	Output port			
	1	0	$\overline{\text{SCK}}$	SO	SI	$\overline{\text{TM1OUT}}$
		1				

**Table 11-5. Read Contents of Port Register (0.73H)**

Port Mode		Read Contents of Port Register (0.73H)
Input port		Pin status
Output port		Contents of output latch
$\overline{\text{SCK}}$	Internal clock selected as serial clock	Contents of output latch
	External clock selected as serial clock	Pin status
SI		Pin status
SO		Contents of output latch
$\overline{\text{TM1OUT}}$		Contents of output latch

**11.5 Port 0E (P0E0, P0E1, P0E2, P0E3)**

Port 0E is a 4-bit I/O port with an output latch. It is mapped at address 6EH of BANK0 of the data memory. The output format is N-ch open-drain output.

This port can be set in the input or output mode in 4-bit units. The input or output mode is specified by P0EGIO (bit 2 of address 2CH) on the register file.

When P0EGIO = 0, all the pins of port 0E are set in the input mode. When an instruction that reads the data of the port register is executed at this time, the pin status is read.

When P0EGIO = 1, all the pins of port 0E are set in the output port, and the contents written to the output latch are output to the pins. When an instruction that reads the port status is executed with the port set in the output mode, the contents of the output latch, instead of the pin status, are read.

A pull-up resistor can be connected on-chip to this port through software. Whether the pull-up resistor is connected is specified by P0EGPU (bit 2 at address 0CH) of the register file. All the four-bit pins are pulled up when P0EGPU = 1. When P0EGPU = 0, the pull-up resistor is not connected.

P0EGIO is cleared to “0” at reset, and all the P0E pins are set in the input mode. The value of the output latch is also cleared to “0”.

**Table 11-6. Writing and Reading Port Register (0.6EH)**

(n = 0 to 3)

P0EGIO RF: 2CH, bit 2	Input/Output Mode of Pin	BANK0 6EH	
		Write	Read
0	Input	Enabled	P0E pin status
1	Output	Write to P0E latch	P0E latch contents

**11.6 Port 0F (P0F0/ $\overline{\text{RLS}}$ , P0F1/ $V_{\text{REF}}$ )**

Port 0F is a 2-bit input port and mapped at address 6FH of BANK0 of the data memory. A pull-up resistor can be connected on-chip bitwise to this port by mask option.

If a read instruction that reads the port register is executed when both pins of port 0F are used as input port pins, the higher 2 bits of the register are fixed to 0, and the pin statuses are read to the lower 2 bits. Executing a write instruction is meaningless as the contents of the port register remain unchanged.

The P0F0/ $\overline{\text{RLS}}$  pin is also used to input a standby mode release signal.

The P0F1/ $V_{\text{REF}}$  pin inputs a reference voltage to the A/D converter when even one of the bits of P0CnIDI (RF: address 1BH, n = 0 to 3) is set to “1”. If an instruction is executed to read the port register when the P0F1/ $V_{\text{REF}}$  pin functions as the  $V_{\text{REF}}$  pin, bit 1 of address 6FH is always cleared to 0.

## 12. 8-BIT TIMERS/COUNTERS (TM0, TM1)

The  $\mu$ PD17149(A1) is provided with two 8-bit timers/counters: timer 0 (TM0) and timer 1 (TM1).

By using the count-up signal of timer 0 as the count pulse to timer 1, the two 8-bit timers can be used as a 16-bit timer.

Each timer is controlled through hardware manipulation by using the PUT or GET instruction or manipulation of the registers on the register file by using the PEEK or POKE instruction.

### 12.1 Configuration of 8-Bit Timers/Counters

Figure 12-1 shows the configuration of the 8-bit timers/counters. An 8-bit timer/counter consists of an 8-bit count register, an 8-bit modulo register, a comparator that compares the value of the count register with that of the modulo register, and a selector that selects the count pulse.

- Cautions**
1. The modulo register is a write register.
  2. The count register is a read register.

Figure 12-1. Configuration of 8-Bit Timer/Counter

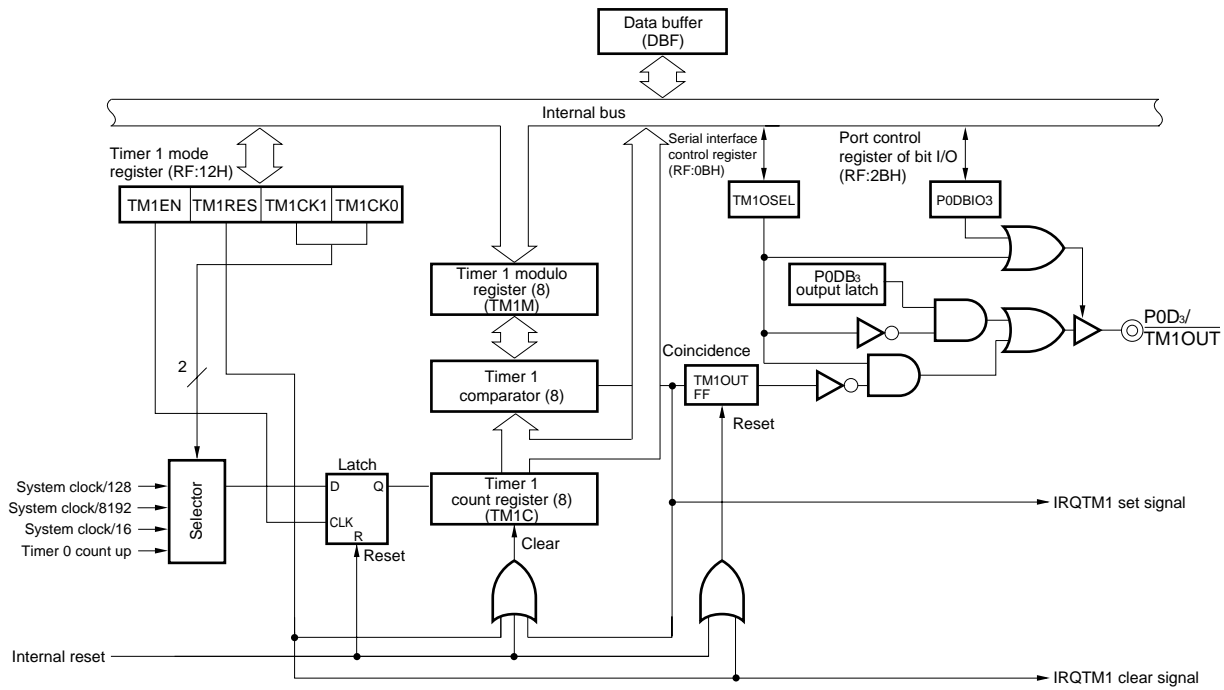
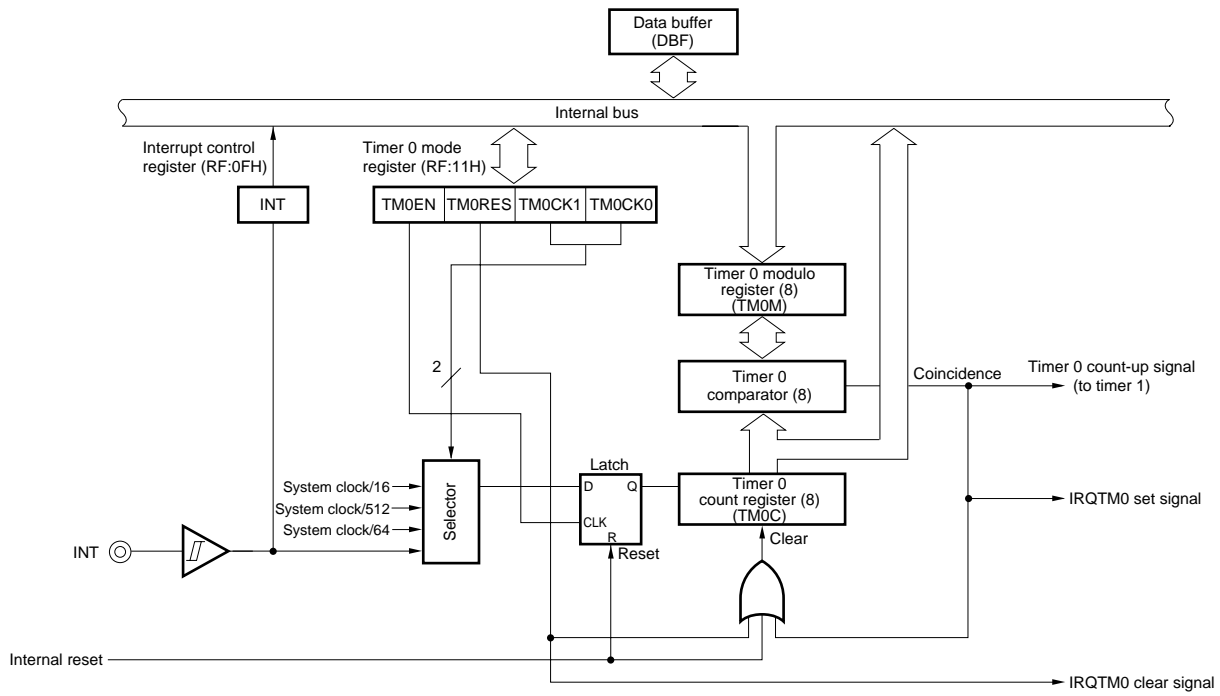
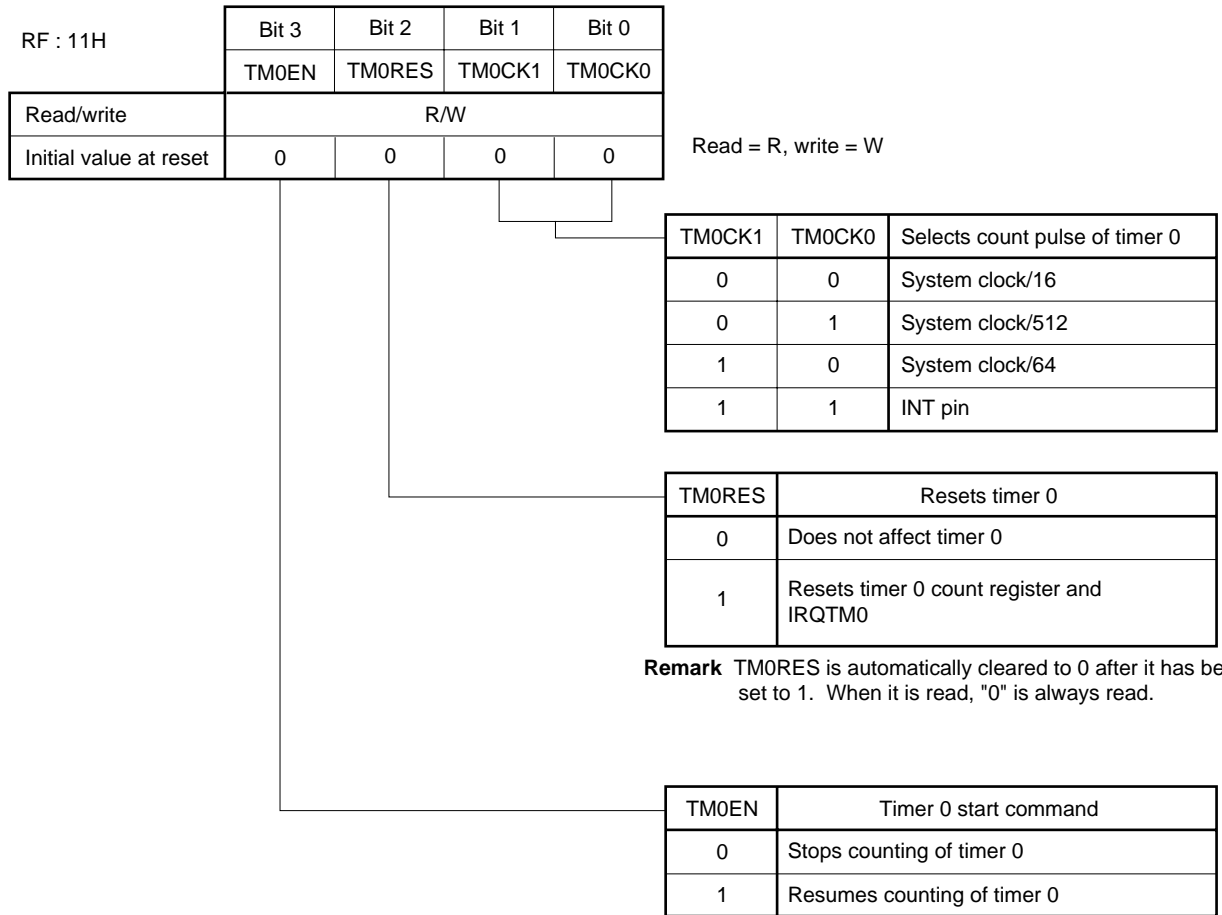

Figure 12-2. Timer 0 Mode Register



**Remark** TM0RES is automatically cleared to 0 after it has been set to 1. When it is read, "0" is always read.

**Remark** TM0EN can be used as a status flag that detects the count status of timer 0 (1 : counting in progress, 0 : counting stopped)

Figure 12-3. Timer 1 Mode Register

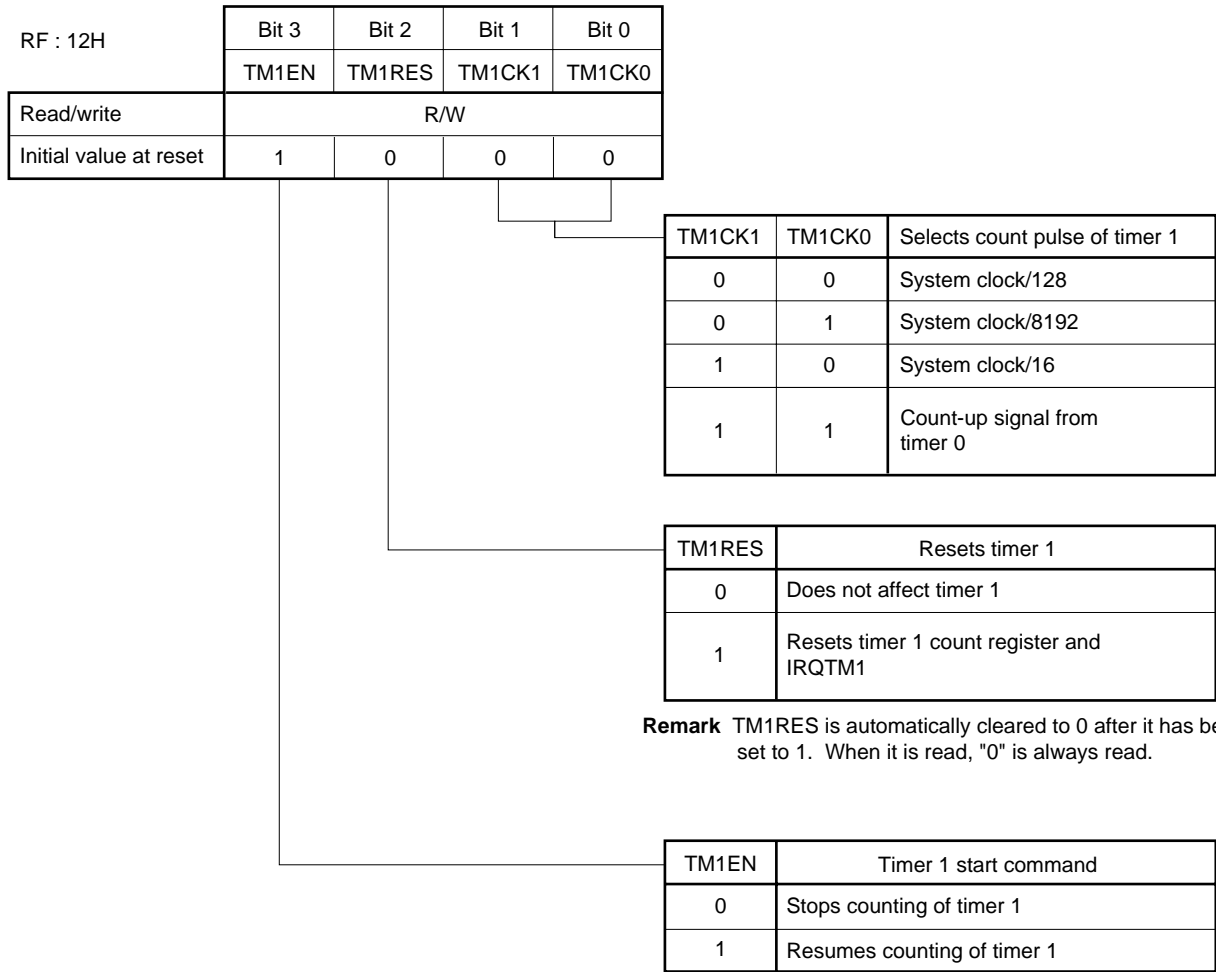

**Remark** TM1RES is automatically cleared to 0 after it has been set to 1. When it is read, "0" is always read.

**Remark** TM1EN can be used as a status flag that detects the count status of timer 1 (1 : counting in progress, 0 : counting stopped)



### 13. BASIC INTERVAL TIMER (BTM)

The  $\mu$ PD17149(A1) is provided with a 7-bit basic interval timer. This timer has the following functions:

- (1) Generates reference time.
- (2) Selects and counts wait time when standby mode is released.
- (3) Watchdog timer function to detect program runaway.

#### 13.1 Configuration of Basic Interval Timer

Figure 13-1 shows the configuration of the basic interval timer.

Figure 13-1. Configuration of Basic Interval Timer

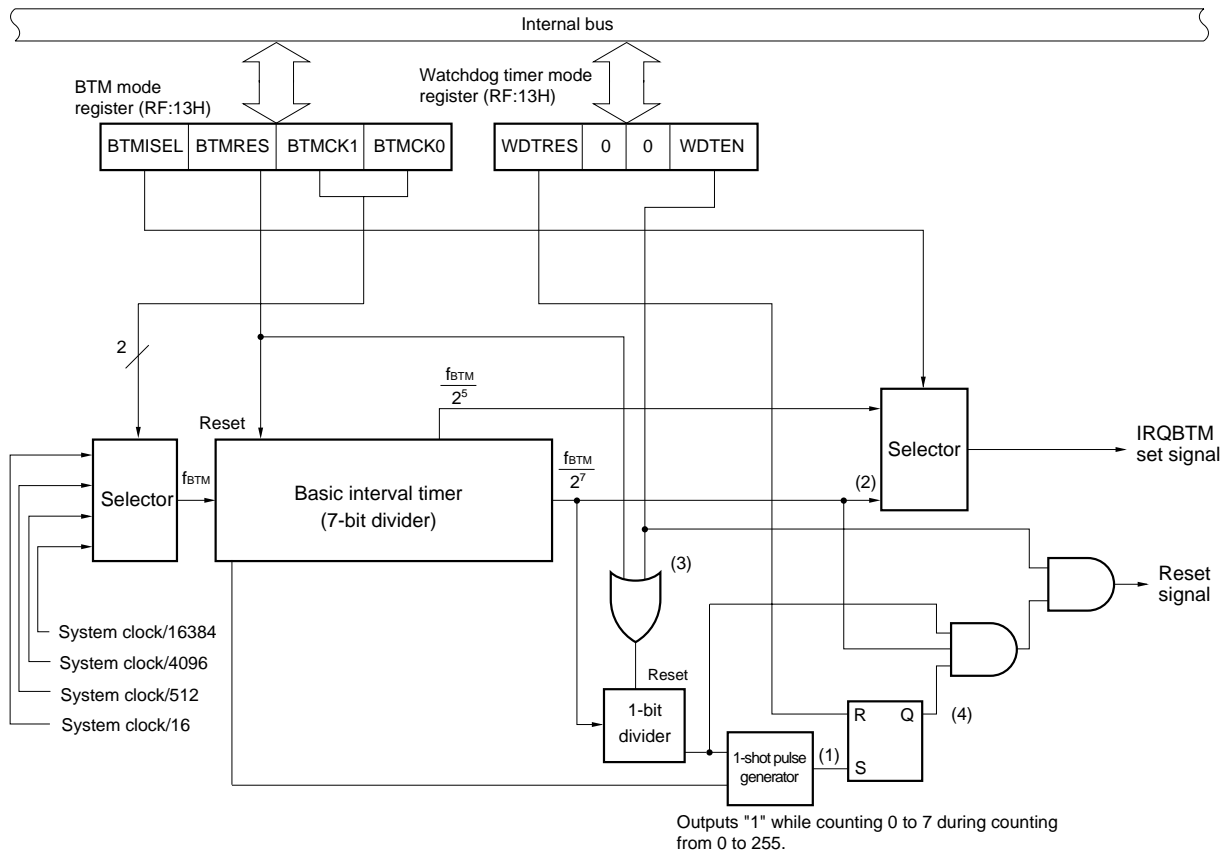

**Remark** (1) to (4) in the figure correspond to the signals in the timing chart in Figure 13-4.

### 13.2 Registers Controlling Basic Interval Timer

The basic interval timer is controlled by the BTM mode register and watchdog timer mode register. Figures 13-2 and 13-3 show the configuration of each register.

**Figure 13-2. BTM Mode Register**

RF : 13H

	Bit 3	Bit 2	Bit 1	Bit 0
	BTMISEL	BTMRES	BTMCK1	BTMCK0
Read/write	R/W			
Initial value at reset	0	0	0	0

Read = R, Write = W

BTMCK1	BTMCK0	Selects count pulse to BTM
0	0	System clock/16 (1 instruction execution time)
0	1	System clock/16384 (1024 instruction execution time)
1	0	System clock/4096 (256 instruction execution time)
1	1	System clock/512 (32 instruction execution time)

BTMRES	Resets BTM
0	Does not affect basic interval timer (BTM)
1	Resets binary counter of basic interval timer (BTM)

**Remark** BTMRES is automatically cleared to 0 after it has been set to 1. When it is read, "0" is always read.

BTMISEL	Selects interval timer
0	Sets interval timer to 1/128 of count pulse
1	Sets interval timer to 1/32 of count pulse

Figure 13-3. Watchdog Timer Mode Register

RF : 03H

	Bit 3	Bit 2	Bit 1	Bit 0
	WDTRES	0	0	WDTEN
Read/write	R/W			
Initial value at reset	0	0	0	0

Read = R, Write = W

WDTEN	Enable watchdog timer
0	Stops watchdog timer.
1	Starts watchdog timer.

- Remark 1.** WDTEN cannot be cleared to 0 by program.
- 2.** WDTEN is automatically cleared to 0 after it has been set to 1. When it is read, "0" is always read.

WDTRES	Resets watchdog timer
0	Does not affect watchdog timer.
1	Resets flip-flop that retains overflow carry of BTM used for watchdog timer.

**Remark** WDTRES is automatically cleared to 0 after it has been set to 1. When it is read, "0" is always read.

### 13.3 Watchdog Timer Function

The basic interval timer can also be used as a watchdog timer that detects a program runaway.

#### 13.3.1 Function of watchdog timer

The watchdog timer is a counter that generates a reset signal at fixed time intervals. By inhibiting generation of this reset signal by program, the system can be reset (started from address 0000H) if the system becomes runaway due to external noise (if the watchdog timer is not reset within specific time).

This function allows the program to escape from the runaway status because a reset signal is generated at fixed time intervals even when the program jumps to an unexpected routine and enters an indefinite loop due to external noise.

#### 13.3.2 Operation of watchdog timer

When WDTEN is set to 1, the 1-bit divider is enabled to operate, and the basic interval timer starts operating as an 8-bit watchdog timer.

Once the watchdog timer has been started, it cannot be stopped until the device is reset and WDTEN is cleared to 0.

Reset effected by the watchdog timer can be inhibited in the following two ways:

- (1) Repeatedly set WDTRES in the program.
- (2) Repeatedly set BTMRES in the program.

In the case of (1), WDTRES must be set while the count value of the watchdog timer is 8 to 191 (before it reaches 192). Therefore, program so that "SET1 WDTRES" is executed at least once in a cycle shorter than that in which the watchdog timer counts 184.

In the case of (2), BTMRES must be set before the basic interval timer (BTM) counts 128. Therefore, program so that "SET1 BTMRES" is executed at least once in a cycle shorter than that in which BTM counts 128. In this case, however, interrupts cannot be processed with BTM.

**Caution** BTM is not reset even if WDTEN is set. Therefore, before setting WDTEN first, be sure to set BTMRES to reset BTM.

#### Example

```
      ⋮  
      SET1 BTMRES  
      SET2 WDTEN, WDTRES  
      ⋮
```

Figure 13-4. Timing Chart of Watchdog Timer (when WDTRES flag is used)

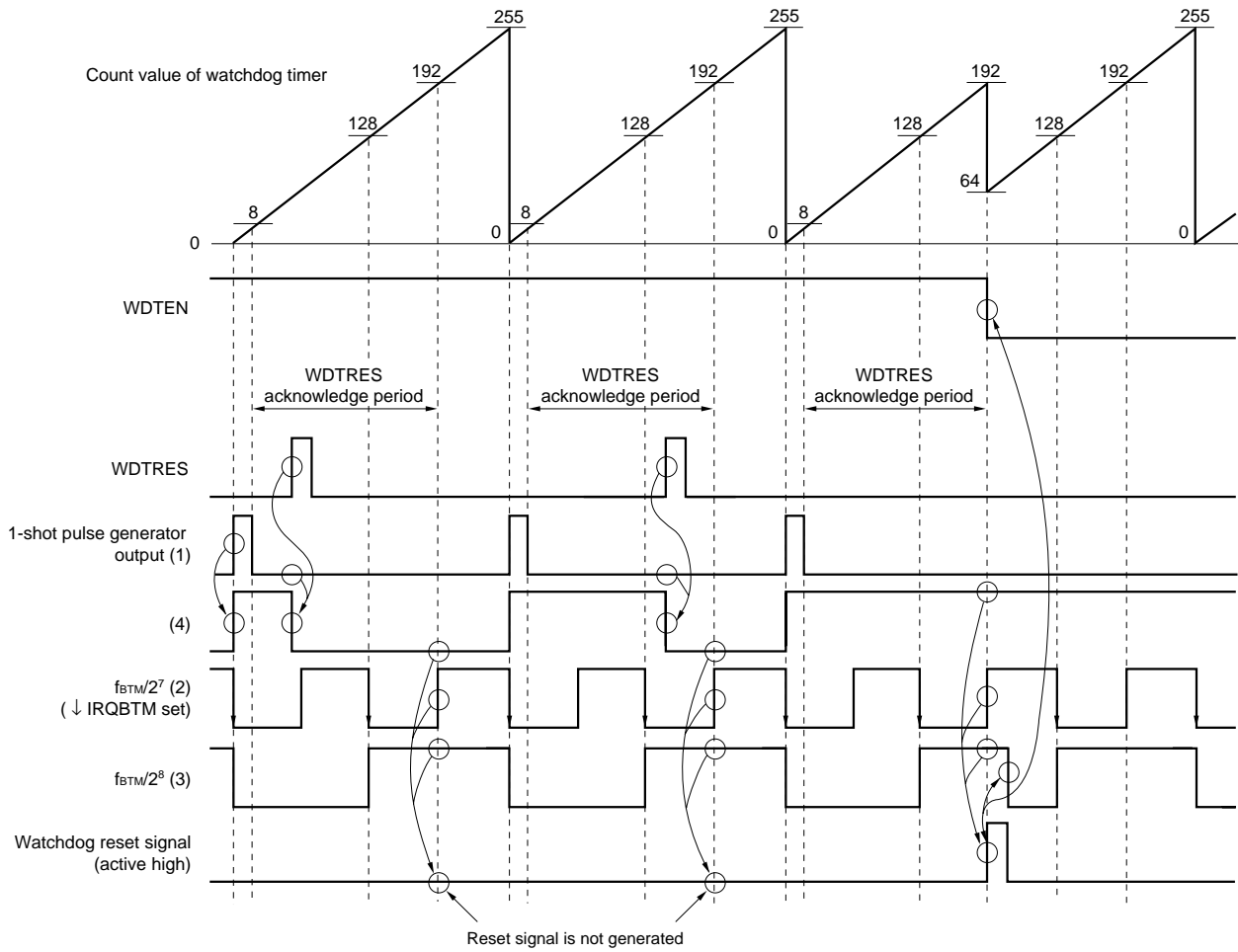

14. A/D CONVERTER

The μPD17149(A1) is provided with an A/D converter with 4 analog input channels (P0C0/ADC0-P0C3/ADC3) and a resolution of 8 bits.

This A/D converter is of the successive approximation type and operates in the following two modes:

- ① Successive mode in which 8-bit A/D conversion is sequentially performed starting from the most significant bit
- ② Single mode in which an input analog voltage is compared with the set value of an 8-bit data register

14.1 Configuration of A/D Converter

Figure 14-1 shows the configuration of the A/D converter.

Figure 14-1. Block Diagram of A/D Converter

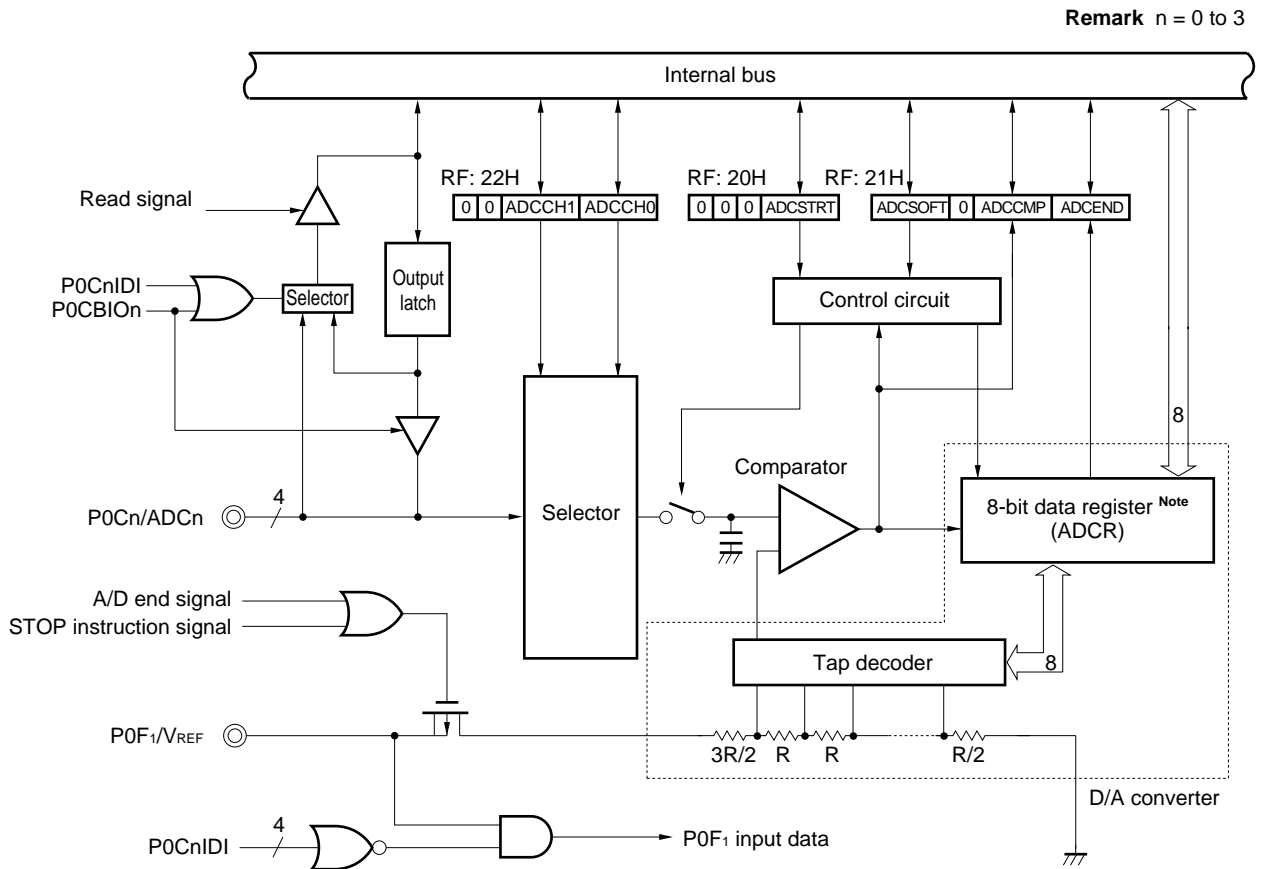

**Note** The 8-bit data register (ADCR) is cleared to 00H when the STOP instruction is executed.

## 14.2 Function of A/D Converter

### (1) ADC<sub>0</sub> to ADC<sub>3</sub> pins

These pins input analog voltages to the four channels of the A/D converter. The analog voltages are converted into digital signals. The A/D converter is provided with a sample and hold circuit, and an analog input voltage being converted into a digital signal is internally held.

### (2) V<sub>REF</sub> pin

This pin inputs a reference voltage to the A/D converter.

The signals input to ADC<sub>0</sub> to ADC<sub>3</sub> are converted into digital signals based on the voltage applied across V<sub>REF</sub> and GND. The A/D converter of the  $\mu$ PD17149(A1) has a function to automatically stop the current flowing into the V<sub>REF</sub> pin when the A/D converter does not operate. A current flows into the V<sub>REF</sub> pin in the following cases:

① **In successive mode (ADCSOFT = 0)**

Since the ADCSTRT flag has been set to 1 until the ADCEND flag is set to 1.

② **In single mode (ADCSOFT = 1)**

Since the ADCSTRT flag has been set to 1 or a value has been written to the 8-bit data register until the result of comparison by the comparator is written to the ADCCMP flag.

- Remarks**
1. If the HALT instruction is executed during A/D conversion, the A/D converter operates, in the successive mode, until the ADCEND flag is set, or in the single mode, until the result of conversion is stored to the ADCCMP flag. Therefore, a current flows to the V<sub>REF</sub> pin during this period.
  2. A/D conversion in progress is stopped if the STOP instruction is executed. In this case, the A/D converter is initialized, and the current flowing to the V<sub>REF</sub> pin is cut (the A/D converter does not operate even if the STOP mode has been released).

### (3) 8-bit data register (ADCR)

This is an 8-bit register that stores the result of A/D conversion of successive approximation type in the successive mode. The contents of this register are read by using the GET instruction. In the single mode, the contents of the 8-bit data register are converted into an analog voltage by an internal D/A converter and is compared by the comparator with an analog signal input from the ADC<sub>n</sub> pin. A value can be written to this register by using the PUT instruction.

### (4) Comparator

The comparator compares the analog input voltage with the voltage output by the D/A converter. If the analog input voltage is high, it outputs "1"; if the voltage is low, the comparator outputs "0". The result of comparison is stored to the 8-bit data register (ADCR) in the successive mode, and to the ADCCMP flag in the single mode.



### 14.3 Operation of A/D Converter

The operation of the A/D converter can be executed in two modes, depending on the setting of the ADCSOFT flag: successive and single modes.

ADCSOFT	Operation Mode of A/D Converter
0	Successive mode (A/D conversion)
1	Single mode (compare operation)

Figure 14-2. Relationships between Analog Input Voltage and Digital Conversion Result

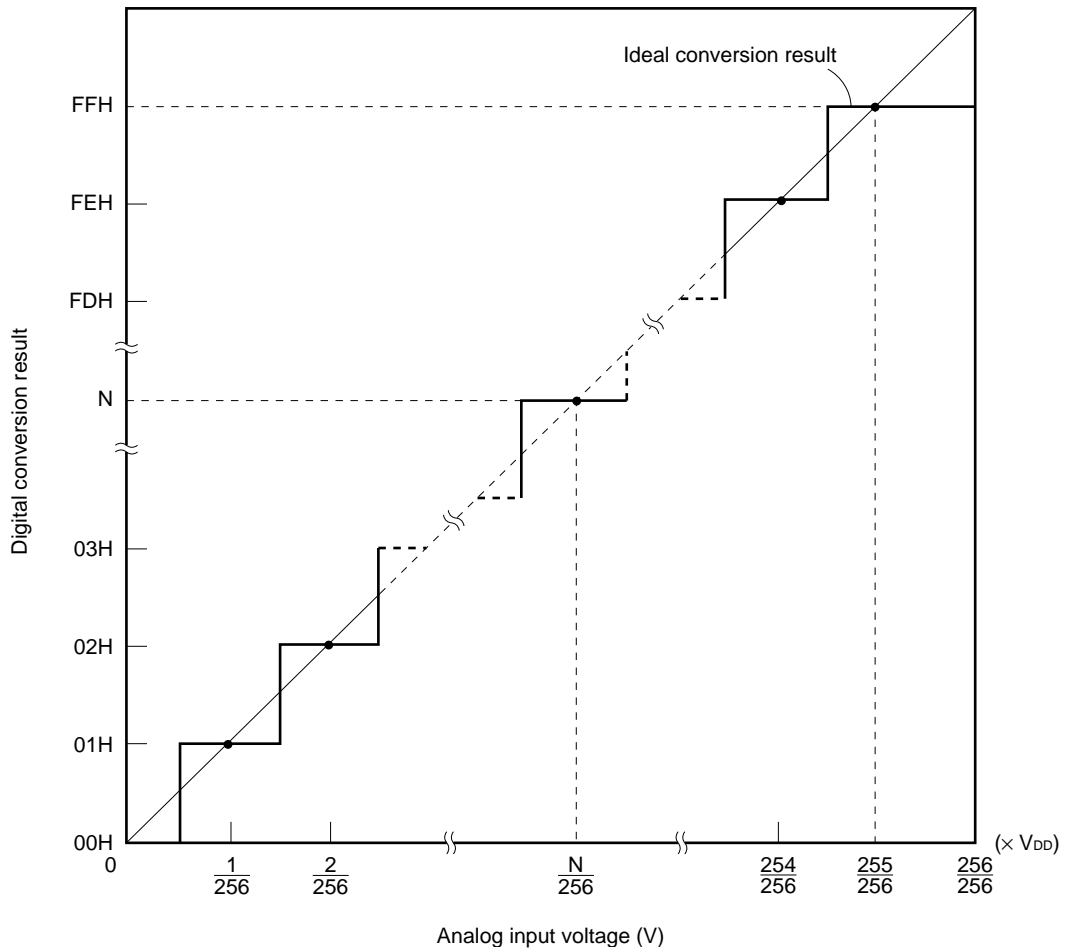

(1) Timing in successive mode (A/D conversion)

Figure 14-3. Timing in Successive Mode (A/D Conversion)

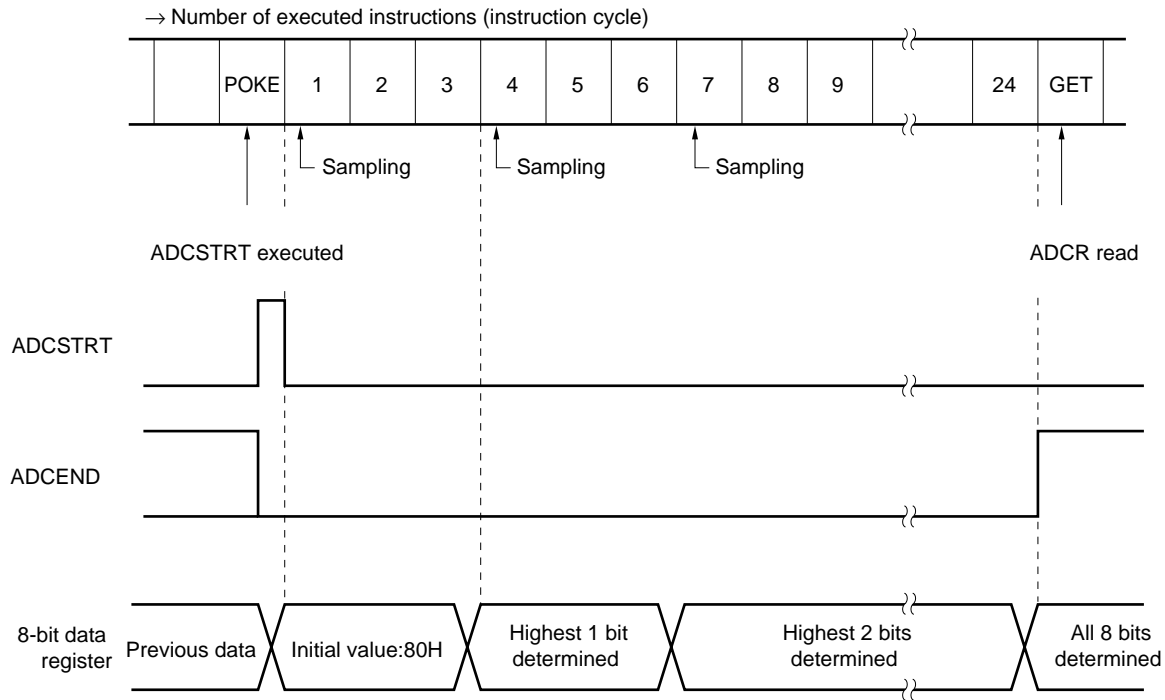

**Caution** Sampling is performed eight times while A/D conversion is executed once. If the analog input voltage changes heavily during A/D conversion, A/D conversion cannot be performed accurately. To obtain an accurate conversion result, it is necessary to minimize the changes in the analog input voltage during A/D conversion.

**Remark** One sampling time =  $14/f_x$  (1.75  $\mu s$ , at 8 MHz)  
 Sampling repeat cycle =  $48/f_x$  (6  $\mu s$ , at 8 MHz)  
 Sampling capacitor capacitance = 100 pF (MAX.)

(2) Timing in single mode (compare operation)

Figure 14-4. Timing in Single Mode (Compare Operation)

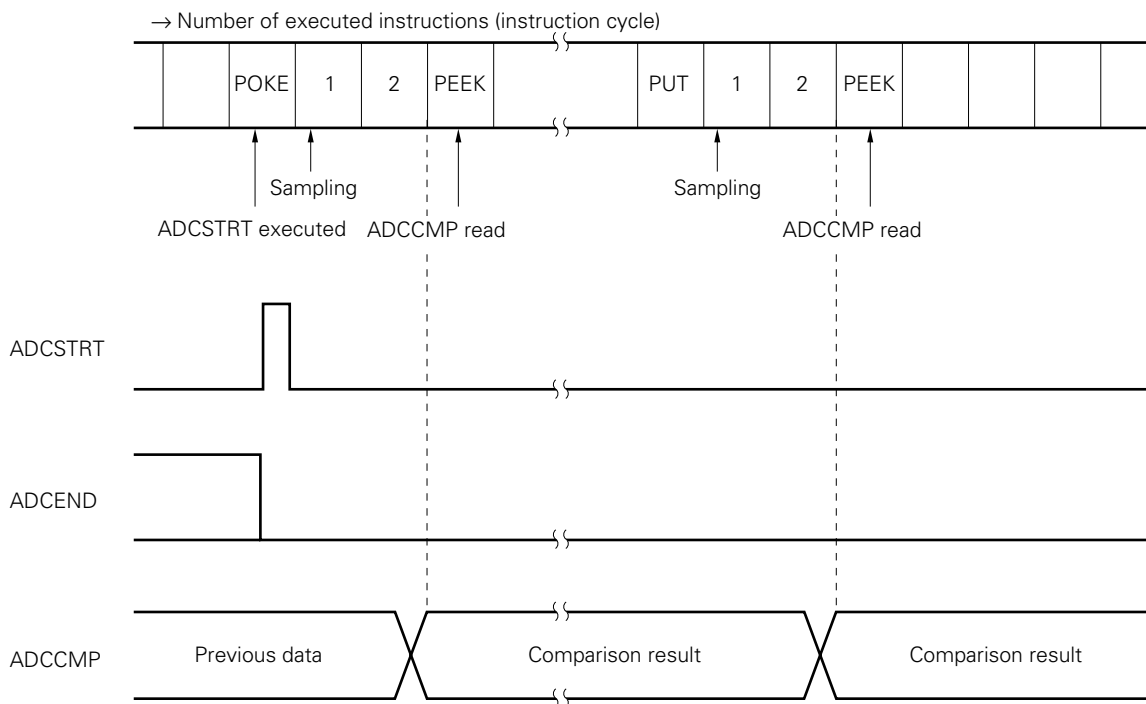

After 1 has been written to ADCSTRT in the single mode (execution of the POKE instruction), a value is stored to ADCCMP three instructions after, and the result of comparison can be read by the PEEK instruction. Even if data is set to ADCR (execution of the PUT instruction), comparison is started in the same manner as ADCSTRT, and the result of comparison can be read three instructions after. The ADCCMP flag is cleared to 0 when reset is executed or when an instruction that writes data to ADCR is executed.

**Caution** Be sure to set ADCSOFT to 1 before setting a value to ADCR. When ADCSOFT = 0, no value can be set to ADCR (the PUT ADCR, DBF instruction is invalidated).

**Remark** Sampling time =  $14/f_x$  (1.75 μs, at 8 MHz)  
 Sampling capacitor capacitance = 100 pF (MAX.)

## 15. SERIAL INTERFACE (SIO)

The serial interface of the μPD17149(A1) consists of an 8-bit shift register (SIOSFR), a serial mode register, and a serial clock counter, and is used to input/output serial data.

### 15.1 Function of Serial Interface

The serial interface can transmit or receive 8-bit data in synchronization with the clock by using three wires: serial clock input ( $\overline{SCK}$ ), serial data output (SO), and serial data input (SI) pins. This serial interface can connect various peripheral I/O devices in a mode compatible with the method employed for the μPD7500 series and 75X series.

#### (1) Serial clock

Four types of serial clocks, three internal and one external, can be selected. If an internal clock is selected as the serial clock, the selected clock is automatically output to the P0D<sub>0</sub>/ $\overline{SCK}$  pin.

**Table 15-1. Serial Clocks**

SIOCK1	SIOCK0	Selected Serial Clock
0	0	External clock from $\overline{SCK}$ pin
0	1	System clock/16
1	0	System clock/128
1	1	System clock/1024

#### (2) Transfer operation

Each pin of port 0D (P0D<sub>0</sub>/ $\overline{SCK}$ , P0D<sub>1</sub>/SO, P0D<sub>2</sub>/SI) functions as a serial interface pin when SIOEN is set to 1. If SIOTS is set to 1 at this time, the serial interface starts its operation in synchronization with the falling edge of the external or internal clock. If SIOTS is set, IRQSIO is automatically cleared.

Data is transferred starting from the most significant bit of the shift register in synchronization with the rising edge of the serial clock, and the information on the SI pin is stored to the shift register, starting from the least significant bit, in synchronization with the rising edge of the serial clock.

When 8-bit data has been completely transferred, SIOTS is automatically cleared, and IRQSIO is set.

**Remark** When serial transfer is executed, transfer is started only from the most significant bit of the contents of the shift register. In other words, transfer cannot be started from the least significant bit. The status of the SI pin is always loaded to the shift register in synchronization with the rising edge of the serial clock.



### 15.2 Operation Mode of 3-Wire Serial Interface

The serial interface can operate in the following two modes. When the serial interface function is selected, the P0D<sub>2</sub>/SI pin always inputs data in synchronization with the serial clock.

- 8-bit transmission/reception mode (simultaneous transmission/reception)
- 8-bit reception mode (SO pin: high-impedance state)

**Table 15-2. Operation Modes of Serial Interface**

SIOEN	SIOHIZ	P0D <sub>0</sub> /SI Pin	P0D <sub>1</sub> /SO Pin	Operation Mode of Serial Interface
1	0	SI	SO	8-bit transmission/reception mode
1	1	SI	P0D <sub>1</sub> (input)	8-bit reception mode
0	×	P0D <sub>0</sub> (I/O)	P0D <sub>1</sub> (I/O)	General-purpose port mode

× : Don't care

#### (1) 8-bit transmission/reception mode (simultaneous transmission/reception)

Input or output of serial data is controlled by the serial clock. The MSB of the shift register is output to the SO line at the falling edge of the serial clock (SCK pin signal). The contents of the shift register are shifted 1 bit at the rising edge of the serial clock. At the same time, the data on the SI line is loaded to the LSB of the shift register.

The serial clock counter (3-bit counter) sets an interrupt request flag (IRQSIO <- 1) each time it has counted eight serial clocks.

**Figure 15-2. Timing in 8-Bit Transmission/Reception Mode (Simultaneous Transmission/Reception)**

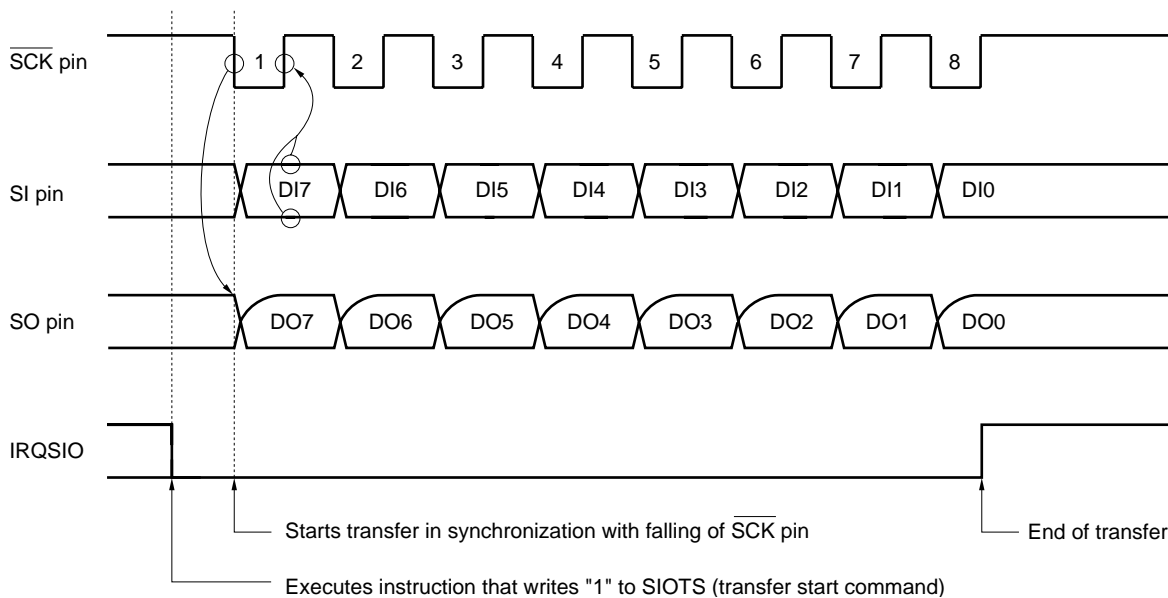

**Remark** DI: serial data input  
DO: serial data output

**(2) 8-bit reception mode (SO pin: high-impedance state)**

The P0D1/SO pin goes into a high-impedance state when SIOHIZ = 1. If supply of the serial clock is started at this time by writing "1" to SIOTS, the serial interface only receives data. Because the P0D1/SO pin goes into a high-impedance state, it can be used as an input port pin (P0D1).

**Figure 15-3. Timing in 8-Bit Reception Mode**

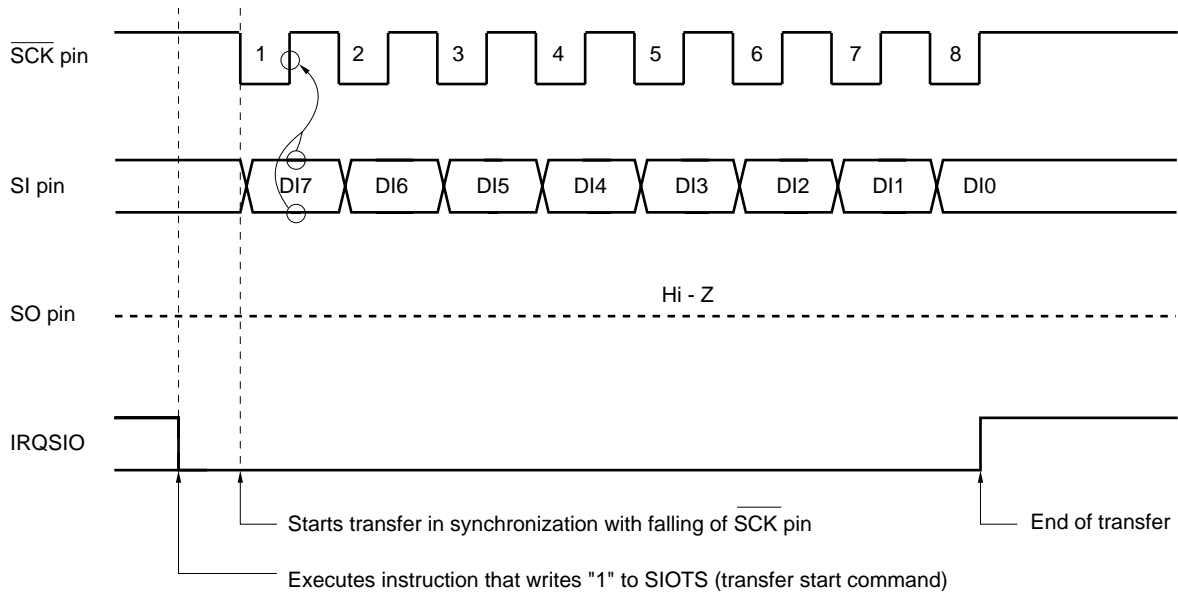

**Remark** DI: serial data input

**(3) Operation stop mode**

When the value of SIOTS (RF: address 02H, bit 3) is 0, the serial interface is set in the operation stop mode. In this mode, serial transfer is not executed. Because the shift register does not perform the shift operation in this mode, it can be used as an ordinary 8-bit register.

## 16. INTERRUPT FUNCTION

The μPD17149(A1) has five interrupt causes, of which four are internal and one is external, enabling various applications.

The interrupt control circuit of the μPD17149(A1) has the following features and can perform interrupt processing at extremely high speeds:

- (a) Acknowledging an interrupt can be controlled by interrupt mask enable flag (INTE) and interrupt enable flag (IPxxx).
- (b) Interrupt request flags (IRQxxx) can be tested and cleared (occurrence of an interrupt can be checked by software).
- (c) Multiple interrupts of up to 3 levels can be processed.
- (d) The standby mode (STOP or HALT) can be released by an interrupt request (releasing condition can be selected by the interrupt enable flag).

**Caution** Only the BCD, CMP, CY, Z, and IXE flags are automatically saved to the stack by hardware when interrupt processing is performed. Up to three levels of multiple interrupts can be processed. If the peripheral hardware (timers, A/D converter, etc.) is accessed during interrupt processing, the contents of DBF and WR are not saved by the hardware. It is therefore recommended that DBF and WR be saved to the RAM by software at the beginning of interrupt processing, and that their contents be restored immediately before the interrupt processing.

### 16.1 Types of Interrupt Causes and Vector Addresses

All the interrupts of the μPD17149 (A1) are vectored interrupts, and therefore, program execution branches to a vector address corresponding to the interrupt cause when an interrupt has been acknowledged. Table 16-1 shows the types of interrupt causes and vector addresses.

If two or more interrupts occur at the same time, or if two or more pending interrupts are enabled all at once, processing is performed according to the priority shown in Table 16-1.

**Table 16-1. Types of Interrupt Causes**

Interrupt Cause	Priority	Vector Address	IRQ Flag	IP Flag	IEG Flag	Internal /External	Remark
INT pin (RF: 0FH, bit 0)	1	0005H	IRQ RF: 3FH, bit 0	IP RF: 2FH, bit 0	IEGMD0, 1 RF:1FH	External	Rising, falling, or both rising and falling edges selectable
Timer 0	2	0004H	IRQTM0 RF: 3EH, bit 0	IPTM0 RF: 2FH, bit 1	—	Internal	
Timer 1	3	0003H	IRQTM1 RF: 3DH, bit 0	IPTM1 RF: 2FH, bit 2	—	Internal	
Basic interval timer	4	0002H	IRQBTM RF: 3CH, bit 0	IPBTM RF: 2FH, bit 3	—	Internal	
Serial interface	5	0001H	IRQSIO RF: 3BH, bit 0	IPSIO RF: 2EH, bit 0	—	Internal	



## 16.2 Hardware of Interrupt Control Circuit

This section describes each flag of the interrupt control circuit.

### (1) Interrupt request flags and interrupt enable flags

An interrupt request flag (IRQ<sub>xxx</sub>) is set to 1 when an interrupt request is generated, and automatically cleared to 0 when interrupt processing is executed.

An interrupt enable flag (IP<sub>xxx</sub>) is provided for each interrupt request flag. The corresponding interrupt is enabled when this flag is “1”, and disabled when the flag is “0”.

### (2) EI/DI instruction

Whether an interrupt that has been acknowledged is executed is specified by the EI or DI instruction.

When the EI instruction is executed, an interrupt enable flag (INTE) that enables acknowledging an interrupt is set to 1. The INTE flag is not registered on the register file. Therefore, the status of this flag cannot be checked by an instruction.

The DI instruction clears the INTE flag to “0”, disabling all the interrupts.

The INTE flag is also cleared to 0 at reset, and therefore all the interrupts are disabled.

**Table 16-2. Interrupt Request Flags and Interrupt Enable Flags**

Interrupt Request Flag	Interrupt Request Flag Setting Signal	Interrupt Enable Flag
IRQ	Sets when edge of INT pin input signal is detected. Edge to be detected is selected by IEGMD0 and IEGMD1 flags.	IP
IRQTM0	Set by coincidence signal from timer 0.	IPTM0
IRQTM1	Set by coincidence signal from timer 1.	IPTM1
IRQBTM	Set by overflow from basic interval timer (reference time interval signal).	IPBTM
IRQSIO	Set when serial interface completes serial data transfer.	IPSIO

## 17. STANDBY FUNCTION

### 17.1 Outline of Standby Function

The current dissipation of the  $\mu$ PD17149(A1) can be reduced by using the standby function. This function can be effected in two modes: STOP and HALT.

The STOP mode stops the system clock. In this mode, the current dissipation by the CPU is minimized with only leakage current flowing. The CPU therefore does not operate, but the contents of the data memory are retained.

In the HALT mode, oscillation of the clock continues. However, supply of the clock to the CPU is stopped. Therefore, the CPU stops operating. This mode cannot reduce the current dissipation as much as the STOP mode. However, because the system clock continues oscillating, the operation can be started immediately after the HALT mode has been released. In both the STOP and HALT modes, the statuses of the data memory, registers, and the output latches of the output ports immediately before the standby mode is set are retained (except STOP 0000B). Therefore, set the port status so that the current dissipation of the entire system is reduced before the standby mode is set.

Table 17-1. Status in Standby Mode

		STOP Mode	HALT Mode
Setting instruction		STOP instruction	HALT instruction
Clock oscillation circuit		Stops oscillation	Continues oscillation
Operating status	CPU	• Stops operation	
	RAM	• Retains previous status	
	Port	• Retains previous status <sup>Note</sup>	
	TM0	• Can operate only when INT input is selected as count clock • Stops when system clock is selected (count value is retained)	• Operable
	TM1	• Stops operation (count value is reset to "0") (count up is disabled)	• Operable
	BTM	• Stops operation (count value is retained)	• Operable
	SIO	• Can operate only when external clock is selected as serial clock <sup>Note</sup>	• Operable
	A/D	• Stops operation <sup>Note</sup> (ADCR <- 00H)	• Operable
	INT	• Can operate	• Operable

**Note** As soon as the STOP 0000B instruction is executed, the pins of these peripherals are set in the input port mode, even when the control signal functions of the pins are used.

- Cautions**
1. Be sure to execute the NOP instruction immediately before the STOP and HALT instructions.
  2. If both the interrupt request flag and interrupt enable flag corresponding to an interrupt are set, and if the interrupt is specified to release the standby mode, the standby mode is not set even if the STOP or HALT instruction is executed.

17.2 HALT Mode

17.2.1 Setting HALT mode

The HALT mode is set when the HALT instruction is executed.

The operand of the HALT instruction, b<sub>3</sub>b<sub>2</sub>b<sub>1</sub>b<sub>0</sub>, specifies the condition under which the HALT mode is released.

Table 17-2. HALT Mode Releasing Condition

Format: HALT b<sub>3</sub>b<sub>2</sub>b<sub>1</sub>b<sub>0</sub>B

Bit	HALT mode releasing condition <sup>Note 1</sup>
b <sub>3</sub>	Enables releasing HALT mode by IRQ <sub>xxx</sub> when 1 <sup>Notes 2, 4</sup>
b <sub>2</sub>	Fixed to "0"
b <sub>1</sub>	Enables forced release of HALT mode by IRQTM1 when 1 <sup>Notes 3, 4</sup>
b <sub>0</sub>	Enables releasing HALT mode by $\overline{RLS}$ input when 1 <sup>Note 4</sup>

- Notes**
1. Only reset ( $\overline{RESET}$  input or POC) is valid when HALT 0000B is specified.
  2. IP<sub>xxx</sub> must be set to 1.
  3. The HALT mode is released regardless of the status of IPTM1.
  4. Even if the HALT instruction is executed with IRQ<sub>xxx</sub> = 1 or  $\overline{RLS}$  input being low, the HALT instruction is ignored (treated as an NOP instruction), and the HALT mode is not set.

17.2.2 Start address after HALT mode is released

The start address from which the program execution is started after the HALT mode has been released differs depending on the interrupt enable condition and the condition under which the HALT mode has been released.

Table 17-3. Start Address after HALT Mode Is Released

Releasing Condition	Start Address after Release
Reset <sup>Note 1</sup>	Address 0
$\overline{RLS}$	Address next to that of HALT instruction
IRQ <sub>xxx</sub> <sup>Note 2</sup>	Address next to that of HALT instruction in DI status
	Interrupt vector in EI status (if two or more IRQ <sub>xxx</sub> flags are set, interrupt vector with higher priority)

- Notes**
1.  $\overline{RESET}$  input and POC are valid as reset.
  2. IP<sub>xxx</sub> must be set to 1 except when the HALT mode is forcibly released by IRQTM1.

Figure 17-1. Releasing HALT Mode

(a) By  $\overline{\text{RESET}}$  input

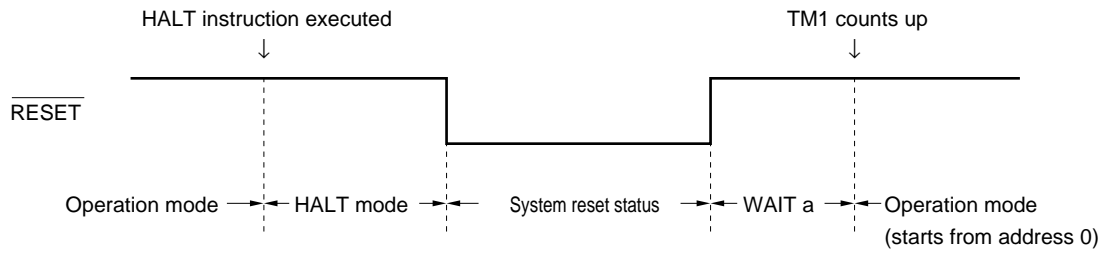

WAIT a : Wait time until TM1 counts 256 clocks divided by 128  
 $256 \times 128 / f_x$  (approx. 4 ms at  $f_x = 8$  MHz)

(b) By  $\overline{\text{RLS}}$  input

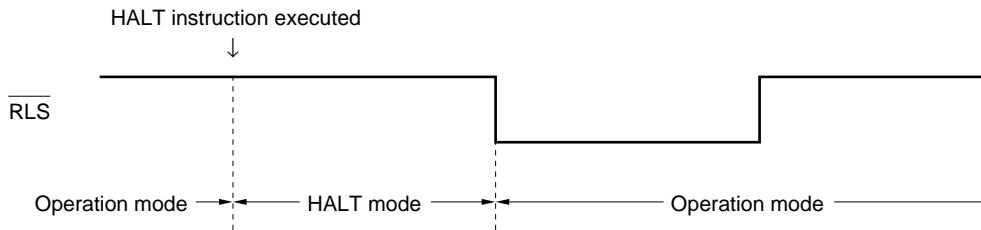

(c) By  $\text{IRQ}_{xxx}$  (in DI status)

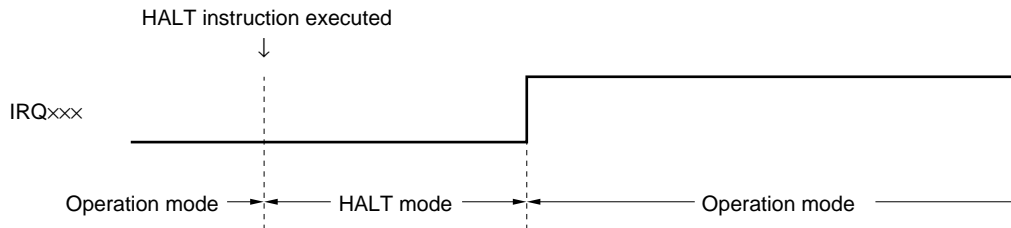

(d) By  $\text{IRQ}_{xxx}$  (in EI status)

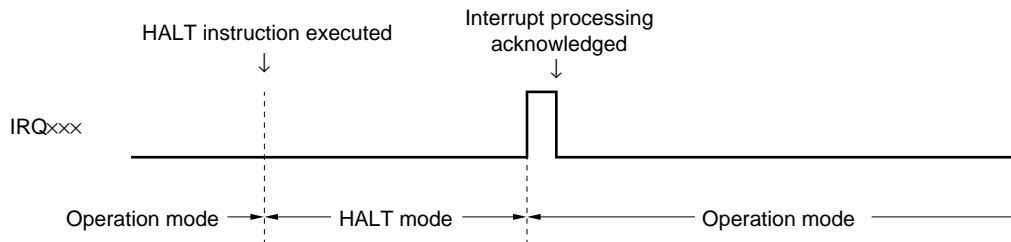

### 17.3 STOP Mode

#### 17.3.1 Setting STOP mode

The STOP mode is set when the STOP instruction is executed.

The operand of the STOP instruction, b<sub>3</sub>b<sub>2</sub>b<sub>1</sub>b<sub>0</sub>, specifies the condition under which the STOP mode is released.

**Table 17-4. STOP Mode Releasing Condition**

Format: STOP b<sub>3</sub>b<sub>2</sub>b<sub>1</sub>b<sub>0</sub>B

Bit	STOP mode releasing condition <sup>Note 1</sup>
b <sub>3</sub>	Enables releasing HALT mode by IRQ <sub>xxx</sub> when 1 <sup>Notes 2, 4</sup>
b <sub>2</sub>	Fixed to "0"
b <sub>1</sub>	Fixed to "0"
b <sub>0</sub>	Enables releasing STOP mode by $\overline{RLS}$ input when 1 <sup>Notes 3, 4</sup>

- Notes**
1. Only reset ( $\overline{RESET}$  input or POC) is valid when STOP 0000B is specified. When STOP 0000B is executed, the internal circuitry of the microcontroller is initialized to the status immediately after reset.
  2. IP<sub>xxx</sub> must be set to 1. The STOP mode cannot be released by IRQ<sub>TM1</sub>.
  3. b<sub>0</sub> alone cannot be set to 1 (STOP 0001B is prohibited).  
Before setting b<sub>0</sub> to 1, be sure to set b<sub>3</sub> to 1.
  4. Even if the STOP instruction is executed with IRQ<sub>xxx</sub> = 1 or the  $\overline{RLS}$  input being low, the STOP instruction is ignored (treated as an NOP instruction), and the STOP mode is not set.

#### 17.3.2 Start address after STOP mode is released

The start address from which the program execution is started after the STOP mode has been released differs depending on the condition under which the STOP mode has been released, and interrupt enable condition.

**Table 17-5. Start Address after STOP Mode Is Released**

Releasing Condition	Start Address after Release
Reset <sup>Note 1</sup>	Address 0
$\overline{RLS}$	Address next to that of STOP instruction
IRQ <sub>xxx</sub> <sup>Note 2</sup>	Address next to that of HALT instruction in DI status
	Interrupt vector in EI status (if two or more IRQ <sub>xxx</sub> flags are set, interrupt vector with higher priority)

- Notes**
1.  $\overline{RESET}$  input and POC are valid as reset.
  2. IP<sub>xxx</sub> must be set to 1. The STOP mode cannot be released by IRQ<sub>TM1</sub>.

Figure 17-2. Releasing STOP Mode

(a) By  $\overline{\text{RESET}}$  input

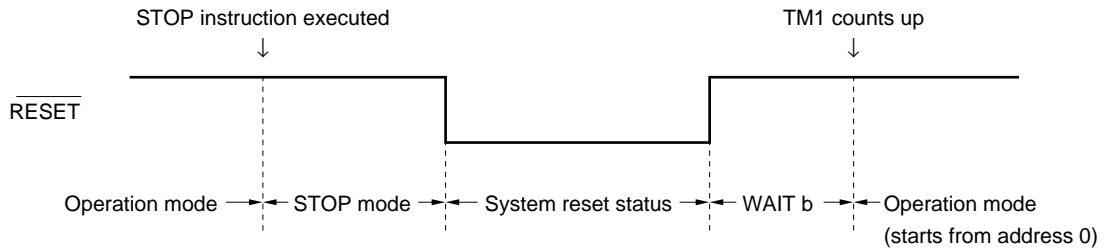

WAIT b : Wait time until TM1 counts 256 clocks divided by 128  
 $256 \times 128 / f_x + \alpha$  (approx. 4 ms +  $\alpha$  at  $f_x = 8$  MHz)  
 $\alpha$  : Oscillation growth time (differs depending on the oscillator)

(b) By  $\overline{\text{RLS}}$  input

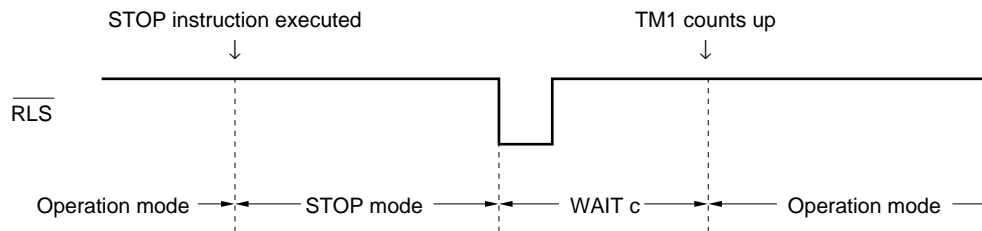

WAIT c : Wait time until TM1 counts clocks divided by m n times  
 $n \times m / f_x + \alpha$  (n and m are values immediately before STOP mode is set)  
 $\alpha$  : Oscillation growth time (differs depending on the oscillator)

(c) By  $\text{IRQ}_{\text{xxx}}$  (in DI status)

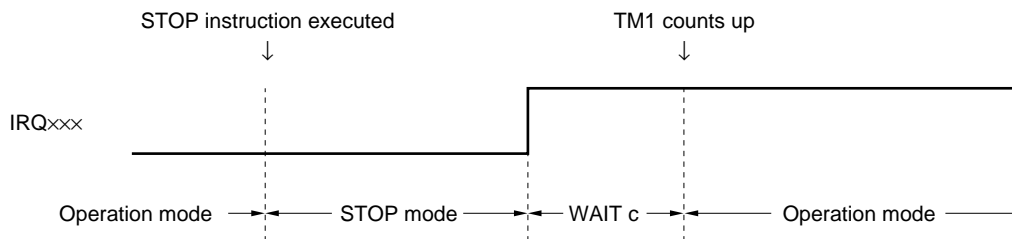

WAIT c : Wait time until TM1 counts clocks divided by m n times  
 $n \times m / f_x + \alpha$  (n and m are values immediately before STOP mode is set)  
 $\alpha$  : Oscillation growth time (differs depending on the oscillator)

(d) By IRQ<sub>xxx</sub> (in EI status)

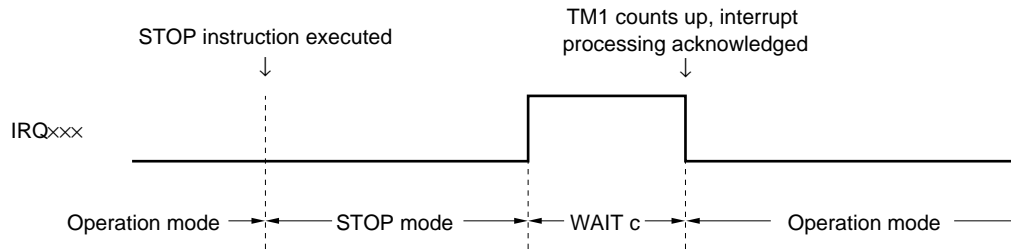

WAIT c : Wait time until TM1 counts clocks divided by m n times  
 $n \times m / f_x + \alpha$  (n and m are values immediately before STOP mode is set)  
 $\alpha$  : Oscillation growth time (differs depending on the oscillator)



**18. RESET**

The μPD17149 (A1) can be reset not only by the  $\overline{\text{RESET}}$  input, but also by the internal POC circuit that detects a supply voltage drop, watchdog timer function that resets the microcontroller if program runaway occurs, and overflow or underflow of the address stack. Note, however, that the internal POC circuit is a mask option.

**18.1 Reset Function**

The reset function initializes the device operation. How the device is initialized differs depending on the type of reset.

**Table 18-1. Hardware Status at Reset**

Type of Reset		• $\overline{\text{RESET}}$ Input during Operation	• $\overline{\text{RESET}}$ Input in Standby Mode	• Overflow of Watchdog Timer
		• Reset by Internal POC Circuit	• Reset by Internal POC Circuit in Standby Mode	• Overflow and Underflow of Stack
Hardware				
Program counter		0000H	0000H	0000H
Port	Input/output	Input	Input	Input
	Contents of output latch	0	0	Undefined
General-purpose data memory	General-purpose data memory (except DBF)	Undefined	Retains contents	Undefined
	DBF	Undefined	Undefined	Undefined
	System register (except WR)	0	0	0
	WR	Undefined	Retains contents	Undefined
Control register		SP = 5H, IRQTM1 = 1, TM1EN = 1, IRQBTM = 1, INT = status at that time. Others are 0. Refer to 8. REGISTER FILE (RF).		SP = 5H, INT = status at that time. Others retain contents.
Timer 0 and timer 1	Count register	00H	00H	Timer 0: 00H, timer 1: undefined
	Modulo register	FFH	FFH	FFH
Binary counter of basic interval timer		Undefined	Undefined	Undefined. However, 40H if watchdog timer overflows.
Serial interface	Shift register (SIOSFR)	Undefined	Retains contents	Undefined
	Output latch	0	0	Undefined
Data register of A/D converter (ADCR)		00H	00H	00H

Figure 18-1. Configuration of Reset Block

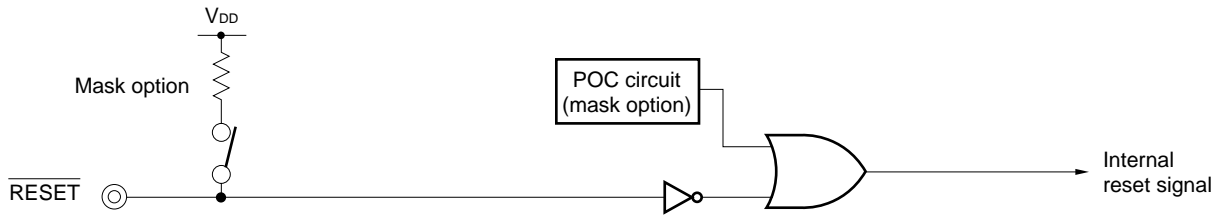

18.2 Reset Operation

Figure 18-2 shows the operation when the system is reset by using the  $\overline{\text{RESET}}$  pin.

When the  $\overline{\text{RESET}}$  pin is made high, oscillation of the system clock is started, oscillation stabilization wait time specified by timer 1 elapses, and program execution is started from address 0000H.

These operations are also performed if the system is reset by the POC circuit.

If the system is reset by using an overflow of the watchdog timer or an overflow or underflow of the stack, the oscillation stabilization wait time (WAIT a) does not elapse, and program execution is started from address 0000H after the internal circuitry has been initialized.

Figure 18-2. Reset Operation

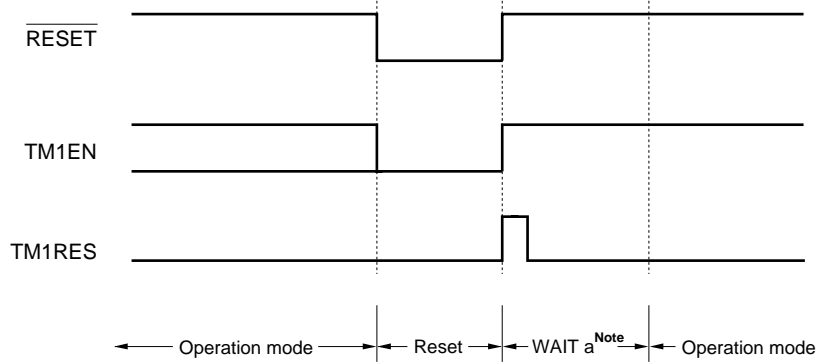

**Note** Oscillation stabilization wait time. An operation mode is set when system clock is counted  $128 \times 256$  times by timer 1 (time required to executed 2048 instructions: approx. 4 ms at 8 MHz).

### 19. POC CIRCUIT (MASK OPTION)

The POC circuit monitors the supply voltage. When the supply voltage is turned ON/OFF, it automatically resets the internal circuitry of the microcontroller. This circuit can be used in an application circuit with a clock frequency of 400 kHz to 4 MHz.

The  $\mu$ PD17149 (A1) can be provided with the POC circuit by mask option.

**Caution** The POC circuit is not provided to the PROM model ( $\mu$ PD17P149).

#### 19.1 Function of POC Circuit

The POC circuit has the following functions:

- Generates internal reset signal when  $V_{DD} \leq V_{POC}$
  - Clears internal reset signal when  $V_{DD} > V_{POC}$
- (where,  $V_{DD}$ : supply voltage,  $V_{POC}$ : POC detection voltage)

**Figure 19-1. Operation of POC Circuit**

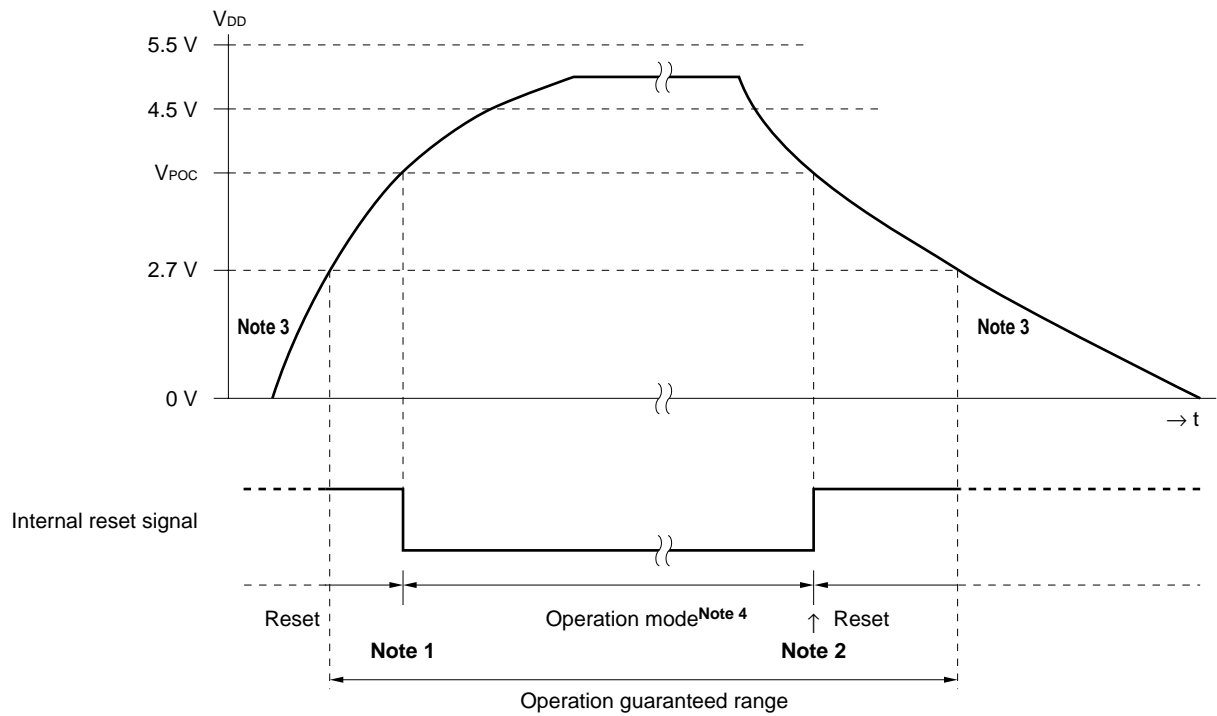

- Notes**
1. Actually, oscillation stabilization wait time specified by timer 1 elapses before the operation mode is set. This time is equal to that required for executing about 2048 instructions (approx. 8 ms at 4 MHz).
  2. To reset the microcontroller again when the supply voltage drops, the status in which the voltage drops below  $V_{POC}$  must be maintained at least for the duration of the reset detection pulse width  $t_{SAMP}$ .  
Therefore, reset is actually effected with a delay time of up to  $t_{SAMP}$ .
  3. The operation is not guaranteed if the supply voltage drops below the rated minimum value (2.7 V).  
However, the POC circuit is designed to generate the internal reset signal so long as it is possible, regardless of oscillation. Therefore, the internal circuitry is reset when the voltage supplied to it has reached the level at which the circuitry can operate.
  4. If the supply voltage abruptly increases (3 V/ms MIN.), the POC circuit may generate the internal reset signal, even in an operation mode, to prevent program runaway.

**Remark** For the values of  $V_{POC}$  and  $t_{SAMP}$ , refer to **22. ELECTRICAL SPECIFICATIONS**.

## 19.2 Conditions to Use POC Circuit

The POC circuit can be used when the application circuit satisfies the following conditions:

- The application circuit does not require a high reliability.
- The operating voltage must range from 4.5 to 5.5 V.
- The clock frequency must range from 400 kHz to 4 MHz.
- The supply voltage must satisfy the ratings of the POC circuit.

- Cautions**
1. **If the application circuit requires an extremely high reliability, design the circuit so that the  $\overline{\text{RESET}}$  signal is input from an external source.**
  2. **The current dissipation in the standby mode slightly increases if the POC circuit is used.**

**Remark** The guaranteed operating voltage range of the POC circuit is  $V_{DD} = 2.7$  to 5.5 V.

20. INSTRUCTION SET

20.1 Outline of Instruction Set

b <sub>14</sub> -b <sub>11</sub>		b <sub>15</sub>		0		1	
		BIN	HEX				
0000	0	ADD	r, m	ADD	m, #n4		
0001	1	SUB	r, m	SUB	m, #n4		
0010	2	ADDC	r, m	ADDC	m, #n4		
0011	3	SUBC	r, m	SUBC	m, #n4		
0100	4	AND	r, m	AND	m, #n4		
0101	5	XOR	r, m	XOR	m, #n4		
0110	6	OR	r, m	OR	m, #n4		
0111	7	INC	AR				
		INC	IX				
		MOVT	DBF, @AR				
		BR	@AR				
		CALL	@AR				
		RET					
		RETSK					
		EI					
		DI					
		RETI					
		PUSH	AR				
		POP	AR				
		GET	DBF, p				
		PUT	p, DBF				
PEEK	WR, rf						
POKE	rf, WR						
RORC	r						
STOP	s						
HALT	h						
NOP							
1000	8	LD	r, m	ST	m, r		
1001	9	SKE	m, #n4	SKGE	m, #n4		
1010	A	MOV	@r, m	MOV	m, @r		
1011	B	SKNE	m, #n4	SKLT	m, #n4		
1100	C	BR	addr (page 0)	CALL	addr		
1101	D	BR	addr (page 1)	MOV	m, #n4		
1110	E			SKT	m, #n		
1111	F			SKF	m, #n		

## 20.2 Legend

AR	: address register
ASR	: address stack register indicated by stack pointer
addr	: program memory address (lower 11 bits)
BANK	: bank register
CMP	: compare flag
CY	: carry flag
DBF	: data buffer
h	: halt release condition
INTEF	: interrupt enable flag
INTR	: register automatically saved to the stack when interrupt processing is performed
INTSK	: interrupt stack register
IX	: index register
MP	: data memory row address pointer
MPE	: memory pointer enable flag
m	: data memory address indicated by m <sub>R</sub> , m <sub>C</sub>
m <sub>R</sub>	: data memory row address (high)
m <sub>C</sub>	: data memory column address (low)
n	: bit position (4 bits)
n4	: immediate data (4 bits)
PAGE	: page (bit 11 of program counter)
PC	: program counter
p	: peripheral address
p <sub>H</sub>	: peripheral address (higher 3 bits)
p <sub>L</sub>	: peripheral address (lower 4 bits)
r	: general register column address
rf	: register file address
rf <sub>R</sub>	: register file row address (higher 3 bits)
rf <sub>C</sub>	: register file column address (lower 4 bits)
SP	: stack pointer
s	: stop release condition
WR	: window register
(x)	: contents addressed by x

20.3 Instruction Set

In-struction	Mnemonic	Operand	Operation	Instruction code			
				op code	Operand		
Addition	ADD	r, m	$(r) \leftarrow (r) + (m)$	00000	m <sub>R</sub>	mc	r
		m, #n4	$(m) \leftarrow (m) + n4$	10000	m <sub>R</sub>	mc	n4
	ADDC	r, m	$(r) \leftarrow (r) + (m) + CY$	00010	m <sub>R</sub>	mc	r
		m, #n4	$(m) \leftarrow (m) + n4 + CY$	10010	m <sub>R</sub>	mc	n4
	INC	AR	$AR \leftarrow AR + 1$	00111	000	1001	0000
		IX	$IX \leftarrow IX + 1$	00111	000	1000	0000
Subtraction	SUB	r, m	$(r) \leftarrow (r) - (m)$	00001	m <sub>R</sub>	mc	r
		m, #n4	$(m) \leftarrow (m) - n4$	10001	m <sub>R</sub>	mc	n4
	SUBC	r, m	$(r) \leftarrow (r) - (m) - CY$	00011	m <sub>R</sub>	mc	r
		m, #n4	$(m) \leftarrow (m) - n4 - CY$	10011	m <sub>R</sub>	mc	n4
Logical operation	OR	r, m	$(r) \leftarrow (r) \vee (m)$	00110	m <sub>R</sub>	mc	r
		m, #n4	$(m) \leftarrow (m) \vee n4$	10110	m <sub>R</sub>	mc	n4
	AND	r, m	$(r) \leftarrow (r) \wedge (m)$	00100	m <sub>R</sub>	mc	r
		m, #n4	$(m) \leftarrow (m) \wedge n4$	10100	m <sub>R</sub>	mc	n4
	XOR	r, m	$(r) \leftarrow (r) \veebar (m)$	00101	m <sub>R</sub>	mc	r
		m, #n4	$(m) \leftarrow (m) \veebar n4$	10101	m <sub>R</sub>	mc	n4
Judgment	SKT	m, #n	$CMP \leftarrow 0$ , if $(m) \wedge n = n$ , then skip	11110	m <sub>R</sub>	mc	n
	SKF	m, #n	$CMP \leftarrow 0$ , if $(m) \wedge n = 0$ , then skip	11111	m <sub>R</sub>	mc	n
Comparison	SKE	m, #n4	$(m) - n4$ , skip if zero	01001	m <sub>R</sub>	mc	n4
	SKNE	m, #n4	$(m) - n4$ , skip if not zero	01011	m <sub>R</sub>	mc	n4
	SKGE	m, #n4	$(m) - n4$ , skip if not borrow	11001	m <sub>R</sub>	mc	n4
	SKLT	m, #n4	$(m) - n4$ , skip if borrow	11011	m <sub>R</sub>	mc	n4
Rotation	RORC	r	$\rightarrow CY \rightarrow (r) b_3 \rightarrow (r) b_2 \rightarrow (r) b_1 \rightarrow (r) b_0 \rightarrow$	00111	000	0111	r
Transfer	LD	r, m	$(r) \leftarrow (m)$	01000	m <sub>R</sub>	mc	r
	ST	m, r	$(m) \leftarrow (r)$	11000	m <sub>R</sub>	mc	r
	MOV	@r, m	if MPE = 1: $(MP, (r)) \leftarrow (m)$ if MPE = 0: $(BANK, m_R, (r)) \leftarrow (m)$	01010	m <sub>R</sub>	mc	r
		m, @r	if MPE = 1: $(m) \leftarrow (MP, (r))$ if MPE = 0: $(m) \leftarrow (BANK, m_R, (r))$	11010	m <sub>R</sub>	mc	r
		m, #n4	$(m) \leftarrow n4$	11101	m <sub>R</sub>	mc	n4
	MOVT	DVF, @AR	$SP \leftarrow SP - 1, ASR \leftarrow PC, PC \leftarrow AR,$ $DBF \leftarrow (PC), PC \leftarrow ASR, SP \leftarrow SP + 1$	00111	000	0001	0000
	PUSH	AR	$SP \leftarrow SP - 1, ASR \leftarrow AR$	00111	000	1101	0000
	POP	AR	$AR \leftarrow ASR, SP \leftarrow SP + 1$	00111	000	1100	0000
	PEEK	WR, rf	$WR \leftarrow (rf)$	00111	r <sub>fR</sub>	0011	r <sub>fC</sub>
	POKE	rf, WR	$(rf) \leftarrow WR$	00111	r <sub>fR</sub>	0010	r <sub>fC</sub>
	GET	DBF, p	$DBF \leftarrow (p)$	00111	p <sub>H</sub>	1011	p <sub>L</sub>
PUT	p, DBF	$(p) \leftarrow DBF$	00111	p <sub>H</sub>	1010	p <sub>L</sub>	

In-struction	Mnemonic	Operand	Operation	Instruction code			
				op code	Operand		
Branch	BR	addr	<b>Note</b>	<b>Note</b>	addr		
		@AR	PC ← AR	00111	000	0100	0000
Subroutine	CALL	addr	SP ← SP - 1, ASR ← PC, PC ← addr	11100	addr		
		@AR	SP ← SP - 1, ASR ← PC, PC ← AR	00111	000	0101	0000
	RET		PC ← ASR, SP ← SP + 1	00111	000	1110	0000
	RETSK		PC ← ASR, SP ← SP + 1 and skip	00111	001	1110	0000
	RETI		PC ← ASR, INTR ← INTSK, SP ← SP + 1	00111	100	1110	0000
Interrupt	EI		INTEF ← 1	00111	000	1111	0000
	DI		INTEF ← 0	00111	001	1111	0000
Others	STOP	s	STOP	00111	010	1111	s
	HALT	h	HALT	00111	011	1111	h
	NOP		No operation	00111	100	1111	0000

**Note** The operation and op code of “BR addr” of the μPD17145(A1), 17147(A1), and μPD17149(A1) are as follows:

(a) μPD17145(A1), 17147(A1)

Mnemonic	Operand	Operation	op code
BR	addr	PC ← addr, PAGE ← 0	01100

(b) μPD17149(A1)

Mnemonic	Operand	Operation	op code
BR	addr	PC ← addr, PAGE ← 0	01100
		PC ← addr, PAGE ← 1	01101



20.4 Assembler (AS17K) Embedded Macro Instruction

Legend

- flag n: FLG type symbol
- < >: Can be omitted

	Mnemonic	Operand	Operation	n
Embedded macro	SKTn	flag 1, ...flag n	if (flag 1) to (flag n) = all "1", then skip	1 ≤ n ≤ 4
	SKFn	flag 1, ...flag n	if (flag 1) to (flag n) = all "0", then skip	1 ≤ n ≤ 4
	SETn	flag 1, ...flag n	(flag 1) to (flag n) ← 1	1 ≤ n ≤ 4
	CLRn	flag 1, ...flag n	(flag 1) to (flag n) ← 0	1 ≤ n ≤ 4
	NOTn	flag 1, ...flag n	if (flag n) = "0", then (flag n) ← 1 if (flag n) = "1", then (flag n) ← 0	1 ≤ n ≤ 4
	INITFLG	<NOT> flag 1, ...<<NOT> flag n>	if description = NOT flag n, then (flag n) ← 0 if description = flag n, then (flag n) ← 1	1 ≤ n ≤ 4
	BANKn		(BANK) ← n	n = 0

**21. ASSEMBLER RESERVED WORDS**

**21.1 Mask Option Directive**

The μPD17149 (A1) has the following mask options:

- Internal pull-up resistor of  $\overline{\text{RESET}}$  pin
- Internal pull-up resistor of P0F<sub>1</sub> and P0F<sub>0</sub> pins
- Internal pull-up resistor of INT pin
- Internal POC circuit

When developing a program, it is necessary to specify all the above mask options in the source program by using a mask option definition directive (pseudo instruction).

**21.1.1 Specifying mask option**

The mask option is described in the assembler source program by using the following directives:

- OPTION directive, ENDOP directive
- Mask option definition directive

**(1) OPTION and ENDOP directives**

These directives specify the range in which the mask option is specified (mask option definition block). Specify the mask option by describing a mask option definition directive in the area sandwiched between the OPTION and ENDOP directives.

Format

<u>Symbol field</u>	<u>Mnemonic field</u>	<u>Operand field</u>	<u>Comment field</u>
[label:]	OPTION		[:comment]
	⋮		
	ENDOP		

(2) Mask option definition directives

Table 21-1. Mask Option Definition Directives

Option	Definition Directive and Format	Operand	Defined Contents
Internal pull-up resistor of $\overline{\text{RESET}}$ pin	OPTRES <operand>	OPEN	None
		PULLUP	Defined
Internal pull-up resistor of P0F <sub>1</sub> and P0F <sub>0</sub> pins	OPTP0F <operand 1>, <operand 2> <sup>Note</sup>	OPEN	None
		PULLUP	Defined
Internal pull-up resistor of INT pin	OPTINT <operand>	OPEN	None
		PULLUP	Defined
Internal POC circuit	OPTPOC <operand>	NOUSE	Not used
		USE	Used

**Note** <operand 1> specifies the mask option of the P0F<sub>1</sub> pin, and <operand 2> specifies that of the P0F<sub>0</sub> pin.

(3) Example of mask option description

; Example of describing mask option of the μPD17149 (A1)

MASK\_OPTION:

```

OPTION                ; start of mask option definition block
OPTRES PULLUP         ; connects internal pull-up resistor to  $\overline{\text{RESET}}$  pin
OPTP0F PULLUP, OPEN  ; connects internal pull-up resistor to P0F1, and leaves P0F0 open (externally pulled up)
OPTINT PULLUP         ; connects internal pull-up resistor to INT pin
OPTPOC NOUSE         ; internal POC circuit is not used
ENDOP                ; End of mask option definition block
    
```

## 21.2 Reserved Symbols

The following tables show the reserved symbols defined by the device file (AS17149) of the  $\mu$ PD17149(A1):

### System register (SYSREG)

Symbol Name	Attribute	Value	Read/Write	Description
AR3	MEM	0.74H	R	Bits b15-b12 of address register
AR2	MEM	0.75H	R/W	Bits b11-b8 of address register
AR1	MEM	0.76H	R/W	Bits b7-b4 of address register
AR0	MEM	0.77H	R/W	Bits b3-b0 of address register
WR	MEM	0.78H	R/W	Window register
BANK	MEM	0.79H	R/W	Bank register
IXH	MEM	0.7AH	R/W	Index register, high
MPH	MEM	0.7AH	R/W	Data memory row address pointer, high
MPE	FLG	0.7AH.3	R/W	Memory pointer enable flag
IXM	MEM	0.7BH	R/W	Index register, middle
MPL	MEM	0.7BH	R/W	Data memory row address pointer, low
IXL	MEM	0.7CH	R/W	Index register, low
RPH	MEM	0.7DH	R/W	General register pointer, high
RPL	MEM	0.7EH	R/W	General register pointer, low
PSW	MEM	0.7FH	R/W	Program status word
BCD	FLG	0.7EH.0	R/W	BCD flag
CMP	FLG	0.7FH.3	R/W	Compare flag
CY	FLG	0.7FH.2	R/W	Carry flag
Z	FLG	0.7FH.1	R/W	Zero flag
IXE	FLG	0.7FH.0	R/W	Index enable flag

Figure 21-1. Configuration of System Register

Address	74H	75H	76H	77H	78H	79H	7AH	7BH	7CH	7DH	7EH	7FH
Name	Address register (AR)				Window register (WR)	Bank register (BANK)	Index register (IX) Data memory row address pointer (MP)			General register pointer (RP)		Program status word (PSWORD)
Symbol	AR3	AR2	AR1	AR0	WR	BANK	IXH MPH	IXM MPL	IXL	RPH	RPL	PSW
Bit	b <sub>3</sub> b <sub>2</sub> b <sub>1</sub> b <sub>0</sub>	b <sub>3</sub> b <sub>2</sub> b <sub>1</sub> b <sub>0</sub>	b <sub>3</sub> b <sub>2</sub> b <sub>1</sub> b <sub>0</sub>	b <sub>3</sub> b <sub>2</sub> b <sub>1</sub> b <sub>0</sub>	b <sub>3</sub> b <sub>2</sub> b <sub>1</sub> b <sub>0</sub>	b <sub>3</sub> b <sub>2</sub> b <sub>1</sub> b <sub>0</sub>	b <sub>3</sub> b <sub>2</sub> b <sub>1</sub> b <sub>0</sub>	b <sub>3</sub> b <sub>2</sub> b <sub>1</sub> b <sub>0</sub>	b <sub>3</sub> b <sub>2</sub> b <sub>1</sub> b <sub>0</sub>	b <sub>3</sub> b <sub>2</sub> b <sub>1</sub> b <sub>0</sub>	b <sub>3</sub> b <sub>2</sub> b <sub>1</sub> b <sub>0</sub>	b <sub>3</sub> b <sub>2</sub> b <sub>1</sub> b <sub>0</sub>
Data <sup>Note 1</sup>	0 0 0 0	Note 2				0 0 0 0	M P E	(IX)		0 0 0 0		B C D P C M Y Z I X E
Initial value at reset	0 0 0 0	0 0 0 0	0 0 0 0	0 0 0 0	0 0 0 0	0 0 0 0	0 0 0 0	0 0 0 0	0 0 0 0	0 0 0 0	0 0 0 0	0 0 0 0

- Notes**
1. "0" in this field means that the bit is fixed to "0".
  2. b<sub>3</sub> and b<sub>2</sub> of AR2 of the μPD17145 (A1) are fixed to 0. b<sub>3</sub> of AR2 of the μPD17147 (A1) is fixed to 0.

**Data buffer (DBF)**

Symbol Name	Attribute	Value	Read/Write	Description
DBF3	MEM	0.0CH	R/W	Bits 15 to 12 of DBF
DBF2	MEM	0.0DH	R/W	Bits 11 to 8 of DBF
DBF1	MEM	0.0EH	R/W	Bits 7 to 4 of DBF
DBF0	MEM	0.0FH	R/W	Bits 3 to 0 of DBF

**Port register**

Symbol Name	Attribute	Value	Read/Write	Description
P0A3	FLG	0.70H.3	R/W	Bit 3 of port 0A
P0A2	FLG	0.70H.2	R/W	Bit 2 of port 0A
P0A1	FLG	0.70H.1	R/W	Bit 1 of port 0A
P0A0	FLG	0.70H.0	R/W	Bit 0 of port 0A
P0B3	FLG	0.71H.3	R/W	Bit 3 of port 0B
P0B2	FLG	0.71H.2	R/W	Bit 2 of port 0B
P0B1	FLG	0.71H.1	R/W	Bit 1 of port 0B
P0B0	FLG	0.71H.0	R/W	Bit 0 of port 0B
P0C3	FLG	0.72H.3	R/W	Bit 3 of port 0C
P0C2	FLG	0.72H.2	R/W	Bit 2 of port 0C
P0C1	FLG	0.72H.1	R/W	Bit 1 of port 0C
P0C0	FLG	0.72H.0	R/W	Bit 0 of port 0C
P0D3	FLG	0.73H.3	R/W	Bit 3 of port 0D
P0D2	FLG	0.73H.2	R/W	Bit 2 of port 0D
P0D1	FLG	0.73H.1	R/W	Bit 1 of port 0D
P0D0	FLG	0.73H.0	R/W	Bit 0 of port 0D
P0E3	FLG	0.6EH.3	R/W	Bit 3 of port 0E
P0E2	FLG	0.6EH.2	R/W	Bit 2 of port 0E
P0E1	FLG	0.6EH.1	R/W	Bit 1 of port 0E
P0E0	FLG	0.6EH.0	R/W	Bit 0 of port 0E
P0F1	FLG	0.6FH.1	R	Bit 1 of port 0F
P0F0	FLG	0.6FH.0	R	Bit 0 of port 0F

Register file (control registers)

Symbol Name	Attribute	Value	Read/Write	Description
SP	MEM	0.81H	R/W	Stack pointer
SIOTS	FLG	0.82H.3	R/W	Serial interface start flag
SIOHIZ	FLG	0.82H.2	R/W	P0D <sub>1</sub> /SO pin function select flag
SIOCK1	FLG	0.82H.1	R/W	Bit 1 of serial clock select flag
SIOCK0	FLG	0.82H.0	R/W	Bit 0 of serial clock select flag
WDTRES	FLG	0.83H.3	R/W	Watchdog timer reset flag
WDTEN	FLG	0.83H.0	R/W	Watchdog timer enable flag
TM1OSEL	FLG	0.8BH.3	R/W	P0D <sub>3</sub> /TM1OUT pin function select flag
SIOEN	FLG	0.8BH.0	R/W	Serial interface enable flag
P0EGPU	FLG	0.8CH.2	R/W	P0E group pull-up select flag (pull-up = 1)
P0BGPU	FLG	0.8CH.1	R/W	P0B group pull-up select flag (pull-up = 1)
P0AGPU	FLG	0.8CH.0	R/W	P0A group pull-up select flag (pull-up = 1)
P0DBPU3	FLG	0.8DH.3	R/W	P0D <sub>3</sub> pull-up select flag (pull-up = 1)
P0DBPU2	FLG	0.8DH.2	R/W	P0D <sub>2</sub> pull-up select flag (pull-up = 1)
P0DBPU1	FLG	0.8DH.1	R/W	P0D <sub>1</sub> pull-up select flag (pull-up = 1)
P0DBPU0	FLG	0.8DH.0	R/W	P0D <sub>0</sub> pull-up select flag (pull-up = 1)
INT	FLG	0.8FH.0	R	INT pin status flag
TM0EN	FLG	0.91H.3	R/W	Timer 0 enable flag
TM0RES	FLG	0.91H.2	R/W	Timer 0 reset flag
TM0CK1	FLG	0.91H.1	R/W	Bit 1 of timer 0 count pulse select flag
TM0CK0	FLG	0.91H.0	R/W	Bit 0 of timer 0 count pulse select flag
TM1EN	FLG	0.92H.3	R/W	Timer 1 enable flag
TM1RES	FLG	0.92H.2	R/W	Timer 1 reset flag
TM1CK1	FLG	0.92H.1	R/W	Bit 1 of timer 1 count pulse select flag
TM1CK0	FLG	0.92H.0	R/W	Bit 0 of timer 1 count pulse select flag
BTMISEL	FLG	0.93H.3	R/W	Basic interval timer interrupt request clock select flag
BTMRES	FLG	0.93H.2	R/W	Basic interval timer reset flag
BTMCK1	FLG	0.93H.1	R/W	Bit 1 of basic interval timer count pulse select flag
BTMCK0	FLG	0.93H.0	R/W	Bit 0 of basic interval timer count pulse select flag
P0C3IDI	FLG	0.9BH.3	R/W	P0C <sub>3</sub> input port disable flag (selects ADC <sub>3</sub> /P0C <sub>3</sub> pin function)
P0C2IDI	FLG	0.9BH.2	R/W	P0C <sub>2</sub> input port disable flag (selects ADC <sub>2</sub> /P0C <sub>2</sub> pin function)
P0C1IDI	FLG	0.9BH.1	R/W	P0C <sub>1</sub> input port disable flag (selects ADC <sub>1</sub> /P0C <sub>1</sub> pin function)
P0C0IDI	FLG	0.9BH.0	R/W	P0C <sub>0</sub> input port disable flag (selects ADC <sub>0</sub> /P0C <sub>0</sub> pin function)
P0CBIO3	FLG	0.9CH.3	R/W	P0C <sub>3</sub> input/output select flag (1 = output port)
P0CBIO2	FLG	0.9CH.2	R/W	P0C <sub>2</sub> input/output select flag (1 = output port)
P0CBIO1	FLG	0.9CH.1	R/W	P0C <sub>1</sub> input/output select flag (1 = output port)
P0CBIO0	FLG	0.9CH.0	R/W	P0C <sub>0</sub> input/output select flag (1 = output port)
IEGMD1	FLG	0.9FH.1	R/W	Bit 1 of INT pin edge detection select flag
IEGMD0	FLG	0.9FH.0	R/W	Bit 0 of INT pin edge detection select flag

## Register file (control registers)

Symbol Name	Attribute	Value	Read/Write	Description
ADCSTRT	FLG	0.0A0H.0	R/W	A/D converter start flag (read: always "0")
ADCSOFT	FLG	0.0A1H.3	R/W	A/D converter mode select flag (1 = single mode)
ADCCMP	FLG	0.0A1H.1	R	A/D converter comparator comparison result flag (valid only in single mode)
ADCEND	FLG	0.0A1H.0	R	A/D converter conversion end flag
ADCCH3	FLG	0.0A2H.3	R/W	Dummy flag
ADCCH2	FLG	0.0A2H.2	R/W	Dummy flag
ADCCH1	FLG	0.0A2H.1	R/W	Bit 1 of A/D converter channel select flag
ADCCH0	FLG	0.0A2H.0	R/W	Bit 0 of A/D converter channel select flag
P0DBIO3	FLG	0.0ABH.3	R/W	P0D <sub>3</sub> input/output select flag (1 = output port)
P0DBIO2	FLG	0.0ABH.2	R/W	P0D <sub>2</sub> input/output select flag (1 = output port)
P0DBIO1	FLG	0.0ABH.1	R/W	P0D <sub>1</sub> input/output select flag (1 = output port)
P0DBIO0	FLG	0.0ABH.0	R/W	P0D <sub>0</sub> input/output select flag (1 = output port)
P0EGIO	FLG	0.0ACH.2	R/W	P0E group input/output select flag (1 = all P0E as output port)
P0BGIO	FLG	0.0ACH.1	R/W	P0B group input/output select flag (1 = all P0B as output port)
P0AGIO	FLG	0.0ACH.0	R/W	P0A group input/output select flag (1 = all P0A as output port)
IPSIO	FLG	0.0AEH.0	R/W	Serial interface interrupt enable flag
IPBTM	FLG	0.0AFH.3	R/W	Basic interval timer interrupt enable flag
IPTM1	FLG	0.0AFH.2	R/W	Timer 1 interrupt enable flag
IPTM0	FLG	0.0AFH.1	R/W	Timer 0 interrupt enable flag
IP	FLG	0.0AFH.0	R/W	INT pin interrupt enable flag
IRQSIO	FLG	0.0BBH.0	R/W	Serial interface interrupt request flag
IRQBTM	FLG	0.0BCH.0	R/W	Basic interval timer interrupt request flag
IRQTM1	FLG	0.0BDH.0	R/W	Timer 1 interrupt request flag
IRQTM0	FLG	0.0BEH.0	R/W	Timer 0 interrupt request flag
IRQ	FLG	0.0BFH.0	R/W	INT pin interrupt request flag



**Peripheral hardware registers**

Symbol Name	Attribute	Value	Read/Write	Description
SIOSFR	DAT	01H	R/W	Peripheral address of shift register
TM0M	DAT	02H	W	Peripheral address of timer 0 modulo register
TM1M	DAT	03H	W	Peripheral address of timer 1 modulo register
ADCR	DAT	04H	R/W	Peripheral address of A/D converter data register
TM0TM1C	DAT	45H	R	Peripheral address of timer 0 timer 1 count register
AR	DAT	40H	R/W	Peripheral address of address register for GET/PUT/ PUSH/CALL/BR/MOVT/INC instruction

**Others**

Symbol Name	Attribute	Value	Description
DBF	DAT	0FH	Fixed operand value of PUT, GET, and MOVT instructions
IX	DAT	01H	Fixed operand value of INC instruction

Figure 21-2. Configuration of Control Register

Column address																																					
Row address	Item	0				1				2				3				4				5				6				7							
0 (8)	Symbol									S	S	S	S	W				W																			
	At reset					0	1	0	1	0	0	0	0	0	0	0	0	0	0	0	0																
	Read/Write					R/W				R/W				R/W																							
1 (9)	Symbol					T	T	T	T	T	T	T	T	B	B	B	B																				
	At reset					0	0	0	0	1	0	0	0	0	0	0	0																				
	Read/Write					R/W				R/W				R/W																							
2 (A)	Symbol	0	0	0		A	A	A	A	A	A	A	A																								
	At reset	0	0	0	0	0	0	0	0	0	0	0	0																								
	Read/Write	R/W				R/W				R	R/W																										
3 (B)	Symbol																																				
	At reset																																				
	Read/Write																																				

**Remark** ( ) is the address when the assembler (AS17K) is used.  
 All the flags of the control register are registered to the device file as assembler reserved words, and are convenient for program development.

Figure 21-2. Configuration of Control Register

8				9				A				B				C				D				E				F											
												T M 1 O S E L				S I O E N				P P P 0 0 0 E B A G G G P P P U U U				P P P P 0 0 0 0 D D D D B B B B P P P U U U 3 2 1 0												I N T			
												0 0 0 0				0 0 0 0				0 0 0 0								0 0 0 0				← Note							
												R/W				R/W				R/W								R											
												P P P P 0 0 0 0 C C C C 3 2 1 0 I I I I D D D D I I I I				P P P P 0 0 0 0 C C C C B B B B I I I I O O O O 3 2 1 0																I I I I E E G G M M D D 1 0							
												0 0 0 0				0 0 0 0												0 0 0 0											
												R/W				R/W												R/W											
												P P P P 0 0 0 0 D D D D B B B B I I I I O O O O 3 2 1 0				P P P P 0 0 0 0 E B A G G G I I I I O O O O								0 0 0 0				I I I I P P P P S B T T O M 1 0				I I I I P P P P							
												0 0 0 0				0 0 0 0								0 0 0 0				0 0 0 0				0 0 0 0							
												R/W				R/W								R/W				R/W											
																I R Q S I O				I R Q B T M				I R Q T M 1				I R Q T M 0				I R Q							
												0 0 0 0				0 0 0 1				0 0 0 1				0 0 0 0				0 0 0 0				0 0 0 0							
												R/W				R/W				R/W				R/W				R/W											

**Note** INT flag differs depending on the status of the INT pin at that time.

22. ELECTRICAL SPECIFICATIONS

Absolute Maximum Ratings (T<sub>a</sub> = 25 °C)

Parameter	Symbol	Condition		Ratings	Unit
Supply voltage	V <sub>DD</sub>			-0.3 to +7.0	V
A/D converter reference voltage	V <sub>REF</sub>			-0.3 to V <sub>DD</sub> + 0.3	V
Input voltage	V <sub>I</sub>	P0A, P0B, P0C, P0D, P0E, P0F, INT, RESET, X <sub>IN</sub>		-0.3 to V <sub>DD</sub> + 0.3	V
Output voltage	V <sub>O</sub>			-0.3 to V <sub>DD</sub> + 0.3	V
High-level output current	I <sub>OH</sub> Note	Per P0A, P0B, or P0C	Peak value	-15	mA
			Effective value	-7.5	mA
		Total of P0A, P0B, and P0C	Peak value	-30	mA
			Effective value	-15	mA
Low-level output current	I <sub>OL</sub> Note	Per P0A, P0B, or P0C	Peak value	15	mA
			Effective value	7.5	mA
		Per P0D or P0E	Peak value	30	mA
			Effective value	15	mA
		Total of P0A, P0B, P0C, P0D, and P0E	Peak value	100	mA
			Effective value	50	mA
Operating temperature	T <sub>opt</sub>			-40 to +110	°C
Storage temperature	T <sub>stg</sub>			-65 to +150	°C
Power dissipation	P <sub>d</sub>	T <sub>a</sub> = 85 °C	28-pin plastic shrink DIP	140	mW
			28-pin plastic SOP	85	mW

**Note** [Effective value] = [Peak value] × √Duty

**Caution** If the value of even one of the above parameters is exceeded even momentarily, the quality of the product may be degraded. The absolute maximum ratings are the values exceeding which may physically damage the product. Be sure to use the product with these values not exceeded.

Recommended Supply Voltage Range (T<sub>a</sub> = -40 to +110 °C)

Parameter	Symbol	Condition		MIN.	TYP.	MAX.	Unit
Supply voltage	V <sub>DD</sub>	CPU (other than A/D converter and POC circuit)	f <sub>x</sub> = 400 kHz to 2 MHz	2.7		5.5	V
			f <sub>x</sub> = 400 kHz to 4 MHz	3.6		5.5	V
			f <sub>x</sub> = 400 kHz to 8 MHz	4.5		5.5	V
		A/D converter	Absolute accuracy: ±1.5LSB, 2.5 V ≤ V <sub>REF</sub> ≤ V <sub>DD</sub>	4.0		5.5	V
		POC circuit (mask option)	f <sub>x</sub> = 400 kHz to 4 MHz	4.5		5.5	V

DC Characteristics (V<sub>DD</sub> = 2.7 to 5.5 V, T<sub>a</sub> = -40 to +110 °C)

Parameter	Symbol	Condition		MIN.	TYP.	MAX.	Unit	
Input voltage, high	V <sub>IH1</sub>	P0A, P0B, P0C, P0D, P0E, P0F		0.7V <sub>DD</sub>		V <sub>DD</sub>	V	
	V <sub>IH2</sub>	$\overline{\text{RESET}}$ , $\overline{\text{SCK}}$ , SI, INT		0.8V <sub>DD</sub>		V <sub>DD</sub>	V	
	V <sub>IH3</sub>	X <sub>IN</sub>		V <sub>DD</sub> - 0.5		V <sub>DD</sub>	V	
Input voltage, low	V <sub>IL1</sub>	P0A, P0B, P0C, P0D, P0E, P0F		0		0.3V <sub>DD</sub>	V	
	V <sub>IL2</sub>	$\overline{\text{RESET}}$ , $\overline{\text{SCK}}$ , SI, INT		0		0.2V <sub>DD</sub>	V	
	V <sub>IL3</sub>	X <sub>IN</sub>		0		0.4	V	
Output voltage, high	V <sub>OH</sub>	P0A, P0B, P0C	4.5 ≤ V <sub>DD</sub> ≤ 5.5 I <sub>OH</sub> = -1.0 mA	V <sub>DD</sub> - 0.3			V	
			2.7 ≤ V <sub>DD</sub> < 4.5 I <sub>OH</sub> = -0.5 mA	V <sub>DD</sub> - 0.3			V	
Output voltage, low	V <sub>OL1</sub>	P0A, P0B, P0C, P0D, P0E	4.5 ≤ V <sub>DD</sub> ≤ 5.5 I <sub>OL</sub> = 1.0 mA			0.3	V	
			2.7 ≤ V <sub>DD</sub> < 4.5 I <sub>OL</sub> = 0.5 mA			0.3	V	
	V <sub>OL2</sub>	P0D, P0E I <sub>OL</sub> = 15 mA	4.5 ≤ V <sub>DD</sub> ≤ 5.5			1.0	V	
			2.7 ≤ V <sub>DD</sub> < 4.5			2.0	V	
Input leakage current, high	I <sub>LIH</sub>	P0A, P0B, P0C, P0D, P0E, P0F V <sub>IN</sub> = V <sub>DD</sub>				5	μA	
Input leakage current, low	I <sub>LIL</sub>	P0A, P0B, P0C, P0D, P0E, P0F V <sub>IN</sub> = 0 V				-5	μA	
Output leakage current, high	I <sub>LOH</sub>	P0A, P0B, P0C, P0D, P0E V <sub>OUT</sub> = V <sub>DD</sub>				5	μA	
Output leakage current, low	I <sub>LOL</sub>	P0A, P0B, P0C, P0D, P0E V <sub>OUT</sub> = 0 V				-5	μA	
Internal pull-up resistor <sup>Note 1</sup>	R <sub>PULL</sub>	P0A, P0B, P0E, P0F, $\overline{\text{RESET}}$ , INT		50	100	250	kΩ	
		P0D		3	10	30	kΩ	
Supply current <sup>†Note 2</sup>	I <sub>DD1</sub>	Operation mode	f <sub>x</sub> = 8.0 MHz V <sub>DD</sub> = 5 V ± 10 %		2.0	4.5	mA	
			f <sub>x</sub> = 4.0 MHz V <sub>DD</sub> = 5 V ± 10 %		1.4	3.3	mA	
			f <sub>x</sub> = 2.0 MHz V <sub>DD</sub> = 3 V ± 10 %		0.5	1.5	mA	
			f <sub>x</sub> = 400 kHz	V <sub>DD</sub> = 5 V ± 10 %		0.9	1.7	mA
				V <sub>DD</sub> = 3 V ± 10 %		0.3	1.0	mA
			I <sub>DD2</sub>	HALT mode	f <sub>x</sub> = 8.0 MHz V <sub>DD</sub> = 5 V ± 10 %		1.0	2.0
	f <sub>x</sub> = 4.0 MHz V <sub>DD</sub> = 5 V ± 10 %				0.9	1.9	mA	
	f <sub>x</sub> = 2.0 MHz V <sub>DD</sub> = 3 V ± 10 %				0.3	1.0	mA	
	f <sub>x</sub> = 400 kHz	V <sub>DD</sub> = 5 V ± 10 %				0.7	1.5	mA
		V <sub>DD</sub> = 3 V ± 10 %		0.3	0.9	mA		
I <sub>DD3</sub>	STOP mode	V <sub>DD</sub> = 5 V ± 10 %			3.0	30	μA	
		V <sub>DD</sub> = 3 V ± 10 %			2.0	30	μA	

**Notes 1.** The pull-up resistors of P0F,  $\overline{\text{RESET}}$ , and INT are mask options.

**2.** Excluding the current of the A/D converter and POC circuit, and the current flowing into the internal pull-up resistor.

AC Characteristics (V<sub>DD</sub> = 2.7 to 5.5 V, T<sub>a</sub> = -40 to +110 °C)

Parameter	Symbol	Condition	MIN.	TYP.	MAX.	Unit
CPU clock cycle time (instruction execution time)	t <sub>CY</sub>	V <sub>DD</sub> = 4.5 to 5.5 V	1.9		41	μs
		V <sub>DD</sub> = 3.6 to 5.5 V	3.9		41	μs
			7.9		41	μs
INT input frequency (TM0 count clock input)	f <sub>INT</sub>		0		400	kHz
INT high-, low-level width (external interrupt input)	t <sub>INTH</sub>	V <sub>DD</sub> = 4.5 to 5.5 V	10			μs
	t <sub>INTL</sub>		50			μs
$\overline{\text{RESET}}$ low-level width	t <sub>RSL</sub>	V <sub>DD</sub> = 4.5 to 5.5 V	10			μs
			50			μs
$\overline{\text{RLS}}$ low-level width	t <sub>RLSL</sub>	V <sub>DD</sub> = 4.5 to 5.5 V	10			μs
			50			μs

**Remark** t<sub>CY</sub> = 16/f<sub>x</sub> (f<sub>x</sub>: system clock oscillation frequency)

Interrupt input timing

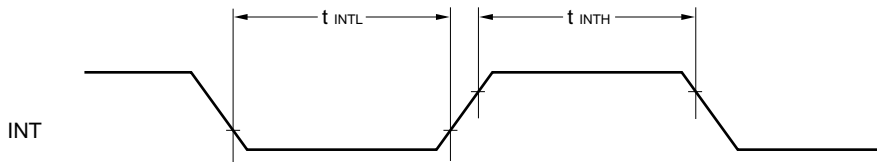

$\overline{\text{RESET}}$  input timing

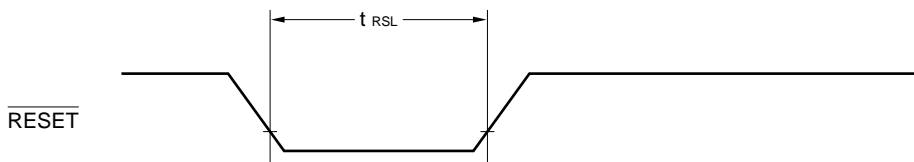

$\overline{\text{RLS}}$  input timing

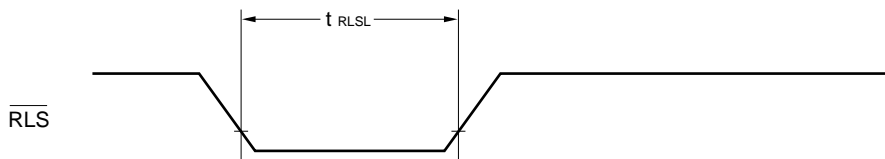

Serial transfer operation ( $V_{DD} = 2.7$  to  $5.5$  V,  $T_a = -40$  to  $+110$  °C)

Parameter	Symbol	Condition	MIN.	TYP.	MAX.	Unit		
$\overline{SCK}$ cycle time	$t_{KCY}$	Input	$V_{DD} = 4.5$ to $5.5$ V	2.0			$\mu$ s	
				10			$\mu$ s	
		Output	$R_L = 1$ k $\Omega$ , $C_L = 100$ pF	$V_{DD} = 4.5$ to $5.5$ V	2.0			$\mu$ s
					8			$\mu$ s
			Internal pull-up, $C_L = 100$ pF	$V_{DD} = 4.5$ to $5.5$ V	32			$\mu$ s
					64			$\mu$ s
$\overline{SCK}$ high-, low-level width	$t_{KH}$ , $t_{KL}$	Input	$V_{DD} = 4.5$ to $5.5$ V	1.0			$\mu$ s	
				5.0			$\mu$ s	
		Output	$R_L = 1$ k $\Omega$ , $C_L = 100$ pF	$V_{DD} = 4.5$ to $5.5$ V	$t_{KCY}/2 - 0.6$			$\mu$ s
					$t_{KCY}/2 - 1.2$			$\mu$ s
			Internal pull-up, $C_L = 100$ pF	$V_{DD} = 4.5$ to $5.5$ V	$t_{KCY}/2 - 12$			$\mu$ s
					$t_{KCY}/2 - 24$			$\mu$ s
SI setup time (to $\overline{SCK} \uparrow$ )	$t_{SIK}$		100			ns		
SI hold time (from $\overline{SCK} \uparrow$ )	$t_{KSI}$		100			ns		
SO output delay time from $\overline{SCK} \downarrow$	$t_{KSO}$	$R_L = 1$ k $\Omega$ , $C_L = 100$ pF	$V_{DD} = 4.5$ to $5.5$ V			0.8	$\mu$ s	
							1.4	$\mu$ s
		Internal pull-up, $C_L = 100$ pF	$V_{DD} = 4.5$ to $5.5$ V				14	$\mu$ s
								26

**Remark**  $R_L$ : load resistance of output line  
 $C_L$ : load capacitance of output line

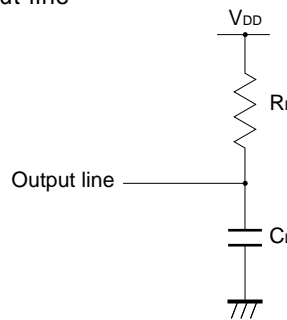

Serial transfer timing

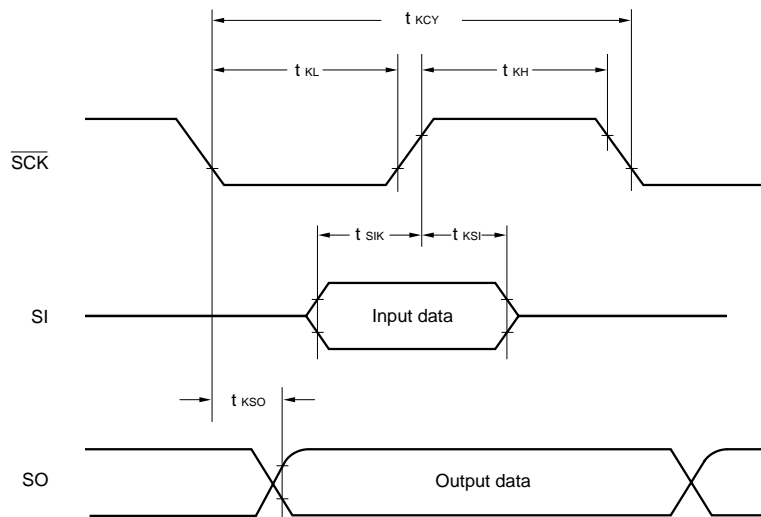

**A/D Converter (V<sub>DD</sub> = 4.0 to 5.5 V, T<sub>a</sub> = -40 to +110 °C)**

Parameter	Symbol	Condition	MIN.	TYP.	MAX.	Unit
Resolution			8	8	8	bit
Absolute accuracy <sup>Note 1</sup>		2.5 V ≤ V <sub>REF</sub> ≤ V <sub>DD</sub>			±1.5	LSB
Conversion time <sup>Note 2</sup>	t <sub>CONV</sub>				25 t <sub>CY</sub>	μs
Analog input voltage	V <sub>ADIN</sub>		0		V <sub>REF</sub>	V
Reference input voltage	V <sub>REF</sub>		2.5		V <sub>DD</sub>	V
A/D converter circuit current	I <sub>ADC</sub>	When A/D converter operates		1.0	2.0	mA
V <sub>REF</sub> pin current	I <sub>REF</sub>			0.1	0.3	mA

- Notes**
1. Absolute accuracy excluding quantization error (±0.5LSB)
  2. Time since a conversion start instruction has been executed until conversion ends (ADCEND = 1) (50 μs at 8 MHz).

**Remark** t<sub>CY</sub> = 16/f<sub>x</sub> (f<sub>x</sub>: system clock oscillation frequency)

**POC Circuit (mask option<sup>Note 1</sup>) (V<sub>DD</sub> = 2.7 to 5.5 V, T<sub>a</sub> = -40 to +110 °C)**

Parameter	Symbol	Condition	MIN.	TYP.	MAX.	Unit
POC detection voltage <sup>Note 2</sup>	V <sub>POC</sub>		3.6	4.0	4.45	V
Supply voltage fall speed	t <sub>POCS</sub>				0.08	V/ms
Reset detection pulse width	t <sub>SAMP</sub>		1			ms
POC circuit current	I <sub>POC</sub>			3.0	10	μA

- Notes**
1. The POC circuit can be used in an application circuit that operates at V<sub>DD</sub> = 4.5 to 5.5 V, f<sub>x</sub> = 400 kHz to 4 MHz.
  2. This is the voltage at which the POC circuit clears its internal reset operation. The internal reset is cleared when V<sub>POC</sub> < V<sub>DD</sub>.



**Oscillator Characteristics ( $V_{DD} = 2.7$  to  $5.5$  V,  $T_a = -40$  to  $+110$  °C)**

Resonator <sup>Note</sup>	Symbol	Condition	MIN.	TYP.	MAX.	Unit
Ceramic resonator	Oscillation frequency		0.39		2.04	MHz
		$V_{DD} = 3.6$ to $5.5$ V	0.39		4.08	MHz
		$V_{DD} = 4.5$ to $5.5$ V	0.39		8.16	MHz

**Note** Do not use a resonator whose oscillation growth time exceeds 2 ms.

**Recommended Ceramic Resonator ( $T_a = -40$  to  $+110$  °C)**

Manufacturer	Part Number	Recommended Constants			Operating Supply Voltage [V]		Remark
		C1 [pF]	C2 [pF]	Rd [kΩ]	MIN.	MAX.	
Murata Mfg. Co.	CSB400JA	220	220	5.6	2.7	5.5	For automotive electronics
	CSA2.00MGA040	100	100	0	2.7	5.5	
	CST2.00MGA040	Unnecessary (C-contained type)		0	2.7	5.5	
	CSA4.00MGA	30	30	0	3.6	5.5	
	CST4.00MGWA	Unnecessary (C-contained type)		0	3.6	5.5	
	CSA8.00MTZA	30	30	0	4.5	5.5	
	CST8.00MTWA	Unnecessary (C-contained type)		0	4.5	5.5	

**External Circuit Example**

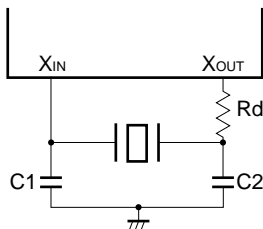

23. CHARACTERISTIC CURVE (REFERENCE VALUE)

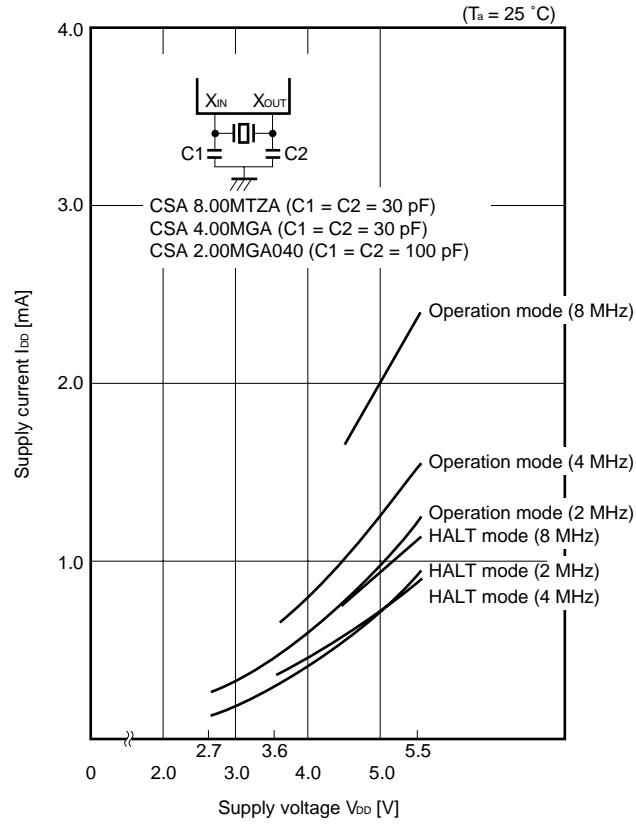

**$I_{OL}$  vs.  $V_{OL}$  Characteristic Example 1 (P0A, P0B, P0C)**

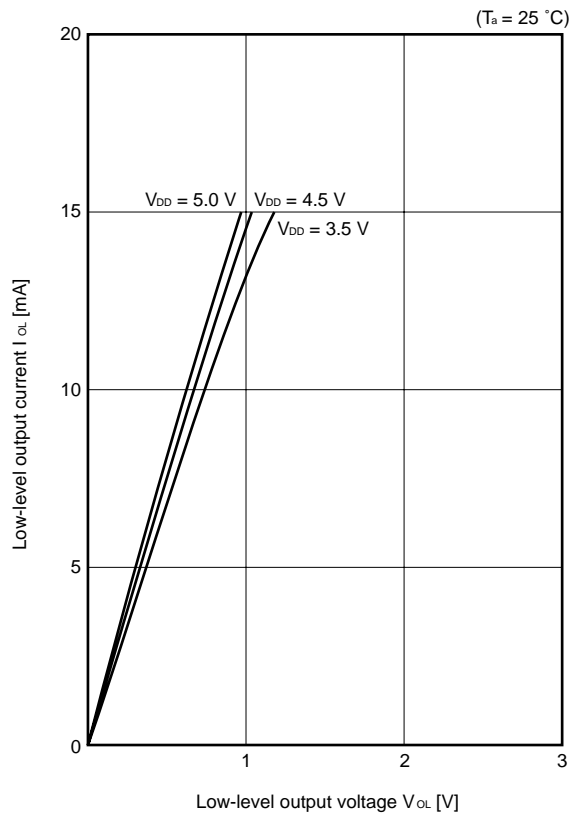

**Caution** The absolute maximum rating is 15 mA (peak value) per pin.

**$I_{OL}$  vs.  $V_{OL}$  Characteristics Example 2 (P0D, P0E)**  
 ( $T_a = 25^\circ\text{C}$ )

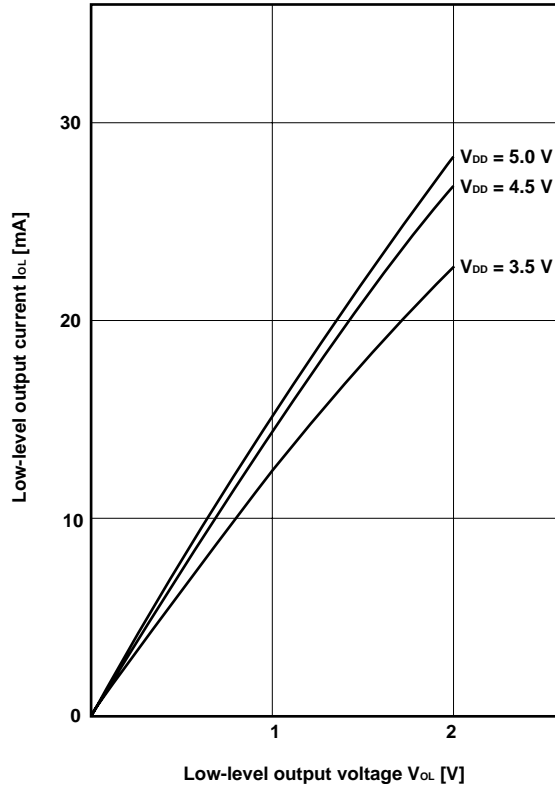

**Caution** The absolute maximum rating is 30 mA (peak value) per pin.

**$I_{OH}$  vs. ( $V_{DD} - V_{OH}$ ) Characteristic Example**  
 ( $T_a = 25^\circ\text{C}$ )

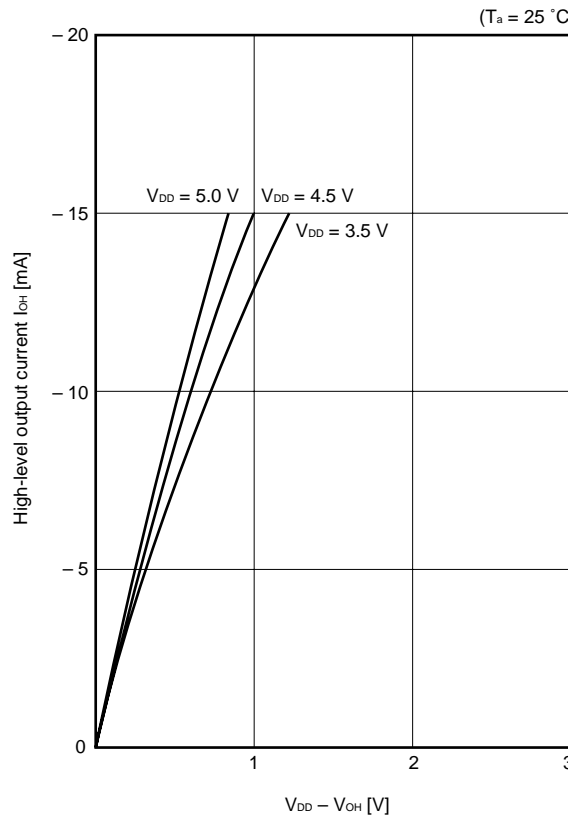

**Caution** The absolute maximum rating is -15 mA (peak value) per pin.

24. PACKAGE DRAWINGS

28 PIN PLASTIC SHRINK DIP (400 mil)

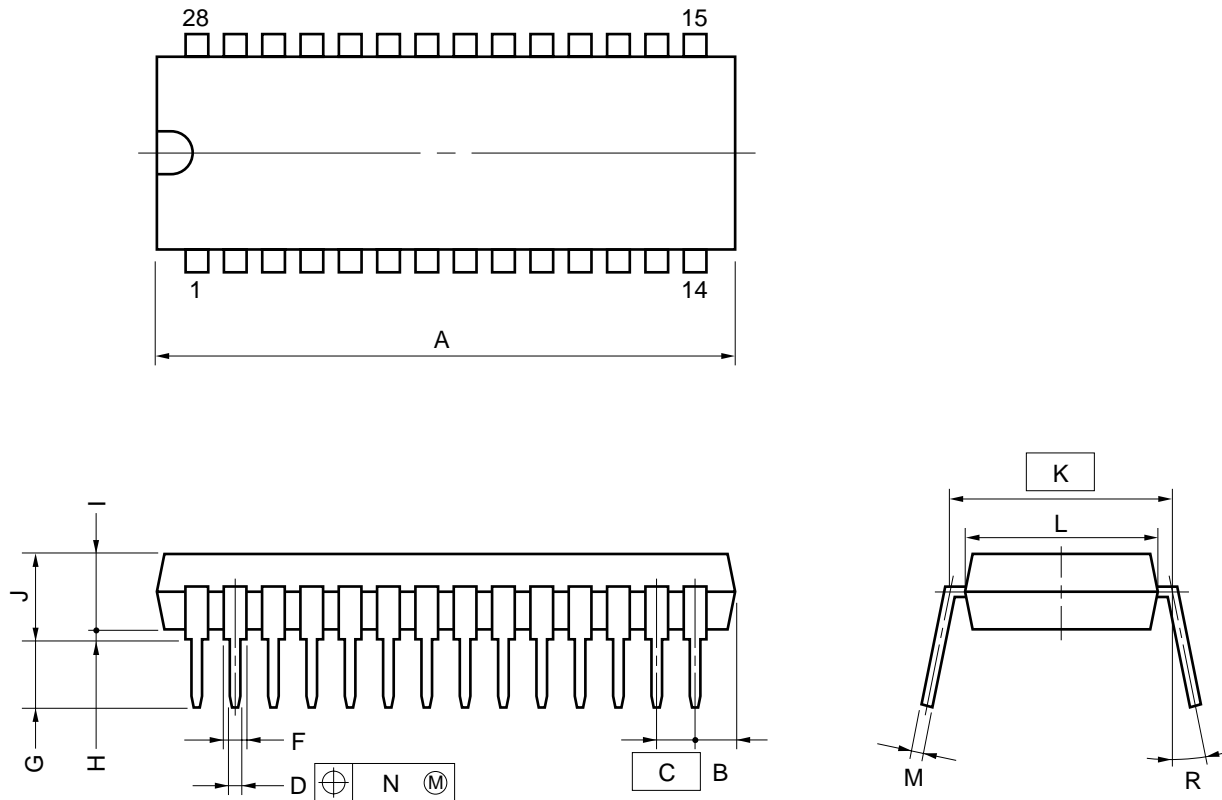

NOTES

- 1) Each lead centerline is located within 0.17 mm (0.007 inch) of its true position (T.P.) at maximum material condition.
- 2) Item "K" to center of leads when formed parallel.

ITEM	MILLIMETERS	INCHES
A	28.46 MAX.	1.121 MAX.
B	2.67 MAX.	0.106 MAX.
C	1.778 (T.P.)	0.070 (T.P.)
D	0.50±0.10	0.020 <sup>+0.004</sup> <sub>-0.005</sub>
F	0.85 MIN.	0.033 MIN.
G	3.2±0.3	0.126±0.012
H	0.51 MIN.	0.020 MIN.
I	4.31 MAX.	0.170 MAX.
J	5.08 MAX.	0.200 MAX.
K	10.16 (T.P.)	0.400 (T.P.)
L	8.6	0.339
M	0.25 <sup>+0.10</sup> <sub>-0.05</sub>	0.010 <sup>+0.004</sup> <sub>-0.003</sub>
N	0.17	0.007
R	0~15°	0~15°

S28C-70-400B-1

**Caution** The ES model differs from the mass-produced model in terms of outline dimensions and materials. Refer to the drawing of the ES model.

28 PIN PLASTIC SOP (375 mil)

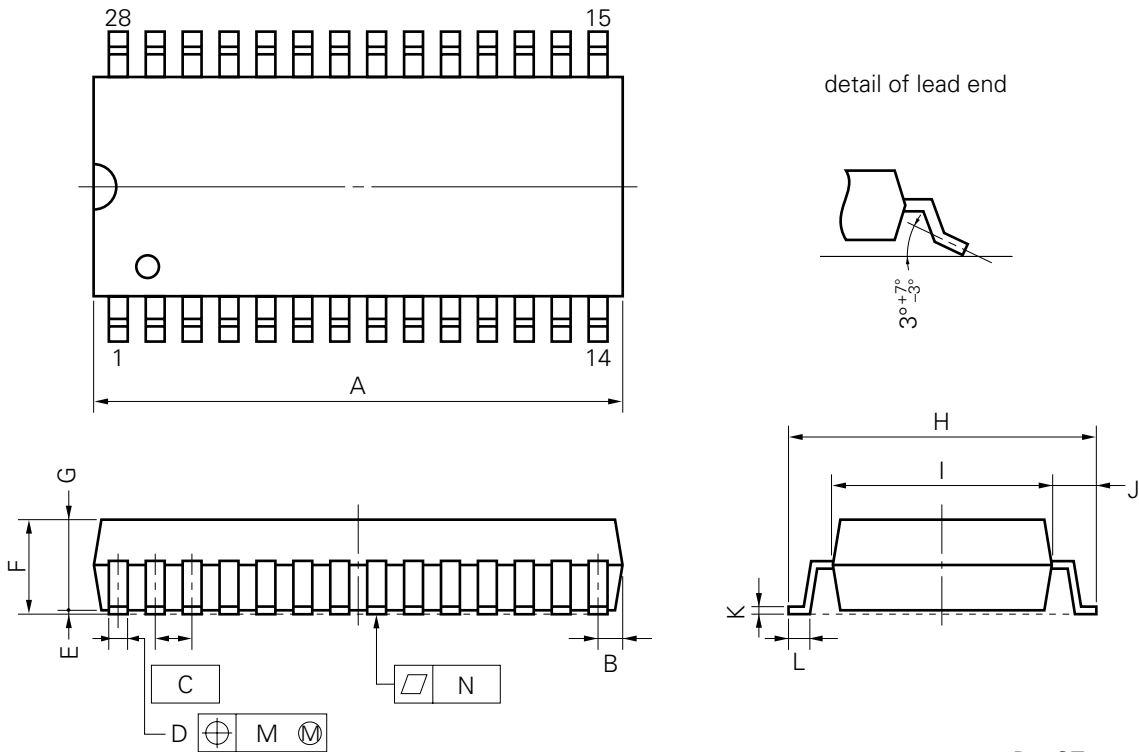

P28GT-50-375B-1

**NOTE**

Each lead centerline is located within 0.12 mm (0.005 inch) of its true position (T.P.) at maximum material condition.

ITEM	MILLIMETERS	INCHES
A	18.2 MAX.	0.717 MAX.
B	0.845 MAX.	0.034 MAX.
C	1.27 (T.P.)	0.050 (T.P.)
D	0.40 <sup>+0.10</sup> <sub>-0.05</sub>	0.016 <sup>+0.004</sup> <sub>-0.003</sub>
E	0.125±0.075	0.005±0.003
F	2.9 MAX.	0.115 MAX.
G	2.50±0.2	0.098 <sup>+0.009</sup> <sub>-0.008</sub>
H	10.3±0.3	0.406 <sup>+0.012</sup> <sub>-0.013</sub>
I	7.2±0.2	0.283 <sup>+0.009</sup> <sub>-0.008</sub>
J	1.6±0.2	0.063±0.008
K	0.15 <sup>+0.10</sup> <sub>-0.05</sub>	0.006 <sup>+0.004</sup> <sub>-0.002</sub>
L	0.8±0.2	0.031 <sup>+0.009</sup> <sub>-0.008</sub>
M	0.12	0.005
N	0.10	0.004

**Caution** The ES model differs from the mass-produced model in terms of outline dimension and materials. Refer to the drawing of the ES model.

28 PIN CERAMIC SHRINK DIP (400 mil) (For ES)

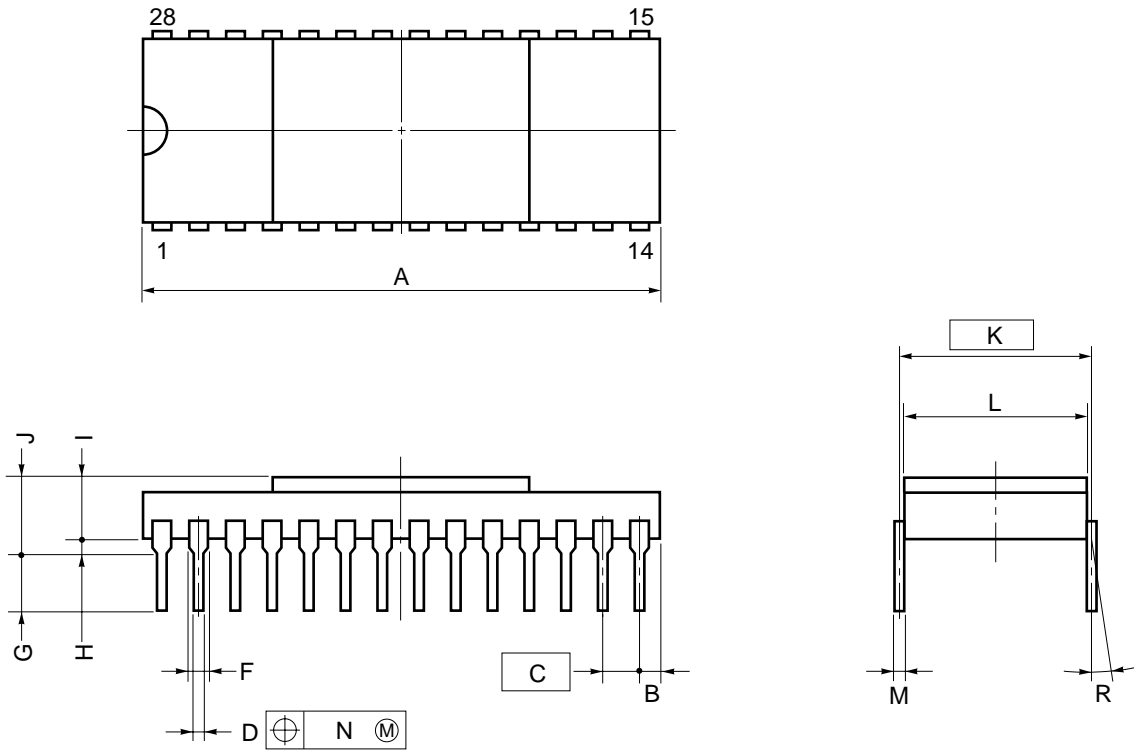

NOTES

- 1) Each lead centerline is located within 0.25 mm (0.01 inch) of its true position (T.P.) at maximum material condition.
- 2) Item "K" to center of leads when formed parallel.

ITEM	MILLIMETERS	INCHES
A	28.0 MAX.	1.103 MAX.
B	5.1 MAX.	0.201 MAX.
C	1.778 (T.P.)	0.070 (T.P.)
D	0.46±0.05	0.018±0.002
F	0.8 MIN.	0.031 MIN.
G	3.0±1.0	0.118±0.04
H	1.0 MIN.	0.039 MIN.
I	2.7	0.106
J	4.3 MAX.	0.170 MAX.
K	10.16 (T.P.)	0.400 (T.P.)
L	9.84	0.387
M	0.25±0.05	0.010 <sup>+0.002</sup> <sub>-0.003</sub>
N	0.25	0.010
R	0~15°	0~15°

P28D-70-400B-1

28 PIN CERAMIC SOP (For ES)

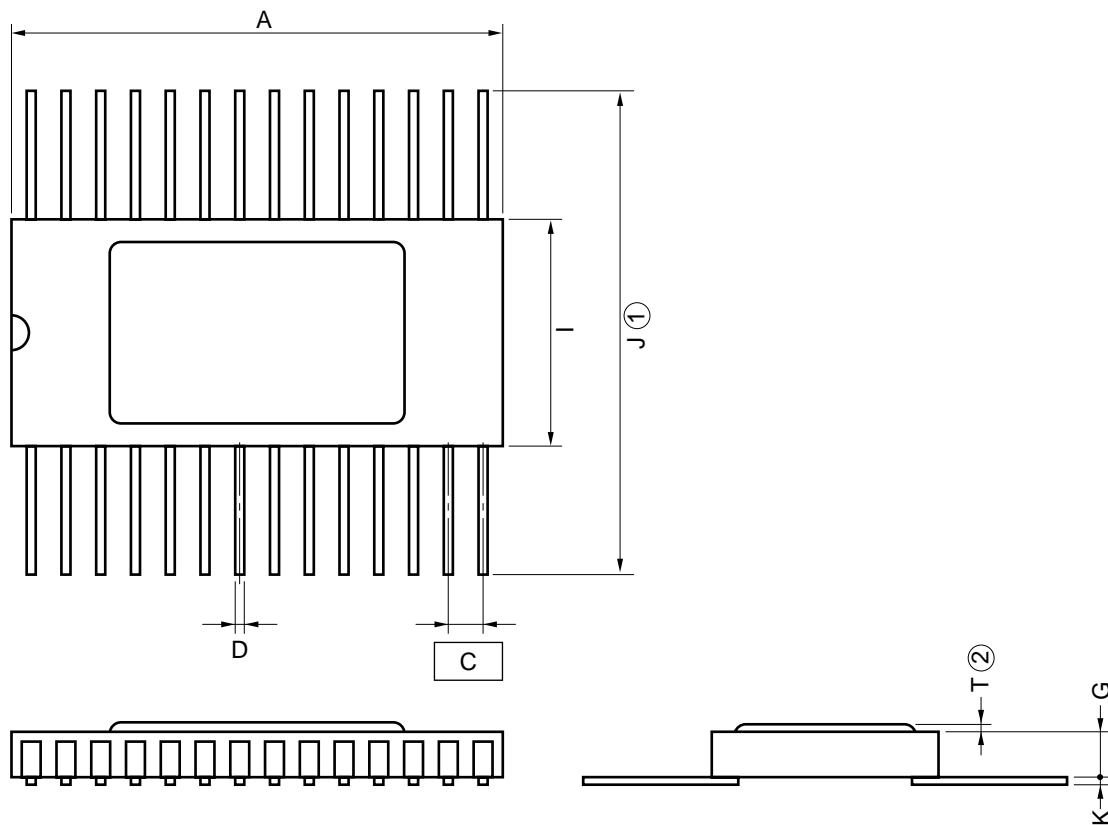

**NOTE**

The lengths of leads (①) and the height of potting (②) are not to be specified because the lead cutting process and the potting process are not controlled.

ITEM	MILLIMETERS	INCHES
A	18.0±0.2	0.709 <sup>+0.008</sup> <sub>-0.009</sub>
C	1.27 (T.P.)	0.05 (T.P.)
D	0.4±0.05	0.016 <sup>+0.002</sup> <sub>-0.003</sub>
G	1.52±0.15	0.06±0.006
I	8.4±0.15	0.331 <sup>+0.006</sup> <sub>-0.007</sub>
J	16.4	0.646
K	0.15±0.025	0.006±0.001
T	1.0	0.039

X28B-50B1

**25. RECOMMENDED SOLDERING CONDITIONS**

Solder this product under the following recommended conditions.

For details of the recommended soldering conditions, refer to Information Document **Semiconductor Device Mounting Technology Manual (C10535E)**.

For the other soldering conditions and methods, consult NEC.

**Table 25-1. Soldering Conditions of Surface Mount Type**

μPD17145GT(A1)-xxx: 28-pin plastic SOP (375 mil)

μPD17147GT(A1)-xxx: 28-pin plastic SOP (375 mil)

μPD17149GT(A1)-xxx: 28-pin plastic SOP (375 mil)

Soldering Method	Soldering Condition	Symbol of Recommended Condition
Infrared reflow	Package peak temperature: 235 °C, Time: 30 seconds max. (210 °C min.), Number of times: 2 max., Duration <sup>Note</sup> : 7 (after that, prebaking is necessary for 20 hours at 125 °C.) <Remarks> (1) Start second reflow after the device temperature that has risen because of the first reflow has fallen to room temperature. (2) Do not clean flux with water after the first reflow.	IR35-207-2
VPS	Package peak temperature: 215 °C, Time: 40 seconds max. (200 °C min.), Number of times: 2 max., Duration <sup>Note</sup> : 7 (after that, prebaking is necessary for 20 hours at 125 °C.) <Remarks> (1) Start second reflow after the device temperature that has risen because of the first reflow has fallen to room temperature. (2) Do not clean flux with water after the first reflow.	VP15-207-2
Pin partial heating	Pin temperature: 300 °C max., Time: 3 seconds max. (per side of device)	—

**Note** Number of storage days after the dry pack was opened. Storage conditions: 25 °C, 65 %RH max.

**Caution** Do not use two or more soldering methods in combination (except pin partial heating).



Table 25-2. Soldering Conditions of Insertion Type

μPD17145CT(A1)-xxx: 28-pin plastic shrink DIP (400 mil)

μPD17147CT(A1)-xxx: 28-pin plastic shrink DIP (400 mil)

μPD17149CT(A1)-xxx: 28-pin plastic shrink DIP (400 mil)

Soldering Method	Soldering Condition
Wave soldering (pin only)	Solder bath temperature: 260 °C max., Time: 10 seconds max.
Pin partial heating	Pin temperature: 300 °C max., Time: 3 seconds max. (per side of pin)

**Caution** When performing wave soldering, exercise care that only the pins are wetted with solder and that no part of the package must be wetted.

APPENDIX A. FUNCTION COMPARISON BETWEEN μPD17145 SUBSERIES AND THE μPD17135A AND 17137A

		μPD17145	μPD17147	μPD17149	μPD17135A	μPD17137A
ROM		2 KB	4 KB	8 KB	2 KB	4 KB
RAM		110 × 4 bits			112 × 4 bits	
Stack		Address stack × 5 levels Interrupt stack × 3 levels				
Instruction execution time (clock, operating voltage)		2 μs (8 MHz, 4.5 to 5.5 V) 4 μs (4 MHz, 3.6 to 5.5 V) 8 μs (2 MHz, 2.7 to 5.5 V)			2 μs (8 MHz, 4.5 to 5.5 V) 4 μs (4 MHz, 2.7 to 5.5 V)	
I/O	CMOS I/O	12 (P0A, P0B, P0C)				
	Input	2 (P0F <sub>0</sub> , P0F <sub>1</sub> )			1 (P1B <sub>0</sub> )	
	Sense input	1 (INT) Can be pulled up by mask option			1 (INT)	
	N-ch open-drain I/O	8 (P0D, P0E voltage: V <sub>DD</sub> ) P0D pull-up: software P0E pull-up: software			8 (P0D, P1A voltage: 9 V) P0D pull-up: mask option P1A pull-up: mask option	
Internal pull-up resistor		100 kΩ TYP. (except P0D) 10 kΩ TYP. (P0D)			100 kΩ TYP.	
A/D converter (operating voltage)		8 bits × 4 channels (V <sub>DD</sub> = 4.0 to 5.5 V)			8 bits × 4 channels (V <sub>DD</sub> = 4.5 to 5.5 V)	
Reference voltage pin		V <sub>REF</sub> (V <sub>REF</sub> = 2.5 V to V <sub>DD</sub> )			None (V <sub>REF</sub> = V <sub>ADC</sub> = V <sub>DD</sub> )	
Timer	8-bit (TM0, TM1)	2 (timer output: $\overline{\text{TM1OUT}}$ ) TM0 clock: system clock/512 system clock/64 system clock/16 INT TM1 clock: system clock/8192 system clock/128 system clock/16 TM0 count up			2 (timer output: $\overline{\text{TM0OUT}}$ ) TM0 clock: system clock/256 system clock/64 system clock/16 INT TM1 clock: system clock/1024 system clock/512 system clock/256 TM0 count up	
	Basic interval (BTM)	1 (also used as watchdog timer) Count clock: system clock/16384 system clock/4096 system clock/512 system clock/16			1 (also used as watchdog timer) Count clock: system clock/8192 system clock/4096 TM0 count up INT	
Interrupt	External	1			1 (with AC zero cross detection)	
	Internal	4 (TM0, TM1, BTM, SIO)				
SIO		1 (clocked 3-wire)				
Output latch		Independent of P0D <sub>i</sub> latch			Shared with P0D <sub>i</sub> latch	
Standby function		HALT, STOP (can be released by $\overline{\text{RLS}}$ input pin)			HALT, STOP	

	μPD17145	μPD17147	μPD17149	μPD17135A	μPD17137A
Oscillation stabilization wait time	128 × 256 counts			512 × 256 counts	
POC function	Mask option			Internal	
Package	28-pin plastic SDIP (400 mil) 28-pin plastic SOP (375 mil)				
One-time PROM	μPD17P149			μPD17P137A	

**Caution** The μPD17145 subseries is not pin-compatible with the μPD17135A and 17137A. The μPD17145 subseries does not include a product equivalent to the μPD17134A and 17136A (RC oscillation type). For the electrical specifications of each product, refer to the Data Sheet of the product.

**APPENDIX B. DEVELOPMENT TOOLS**

The following development tools are available for developing programs for the μPD17145(A1), 17147(A1), and 17149(A1):

**Hardware**

Name	Outline
In-circuit emulator ( IE-17K, IE-17K-ET <sup>Note 1</sup> , EMU-17K <sup>Note 2</sup> )	IE-17K, IE-17K-ET, and EMU-17K are in-circuit emulators that can be used with any products in the 17K series. IE-17K and IE-17K-ET are connected to PC-9800 series or IBM PC/AT™ as the host machine with RS-232-C. EMU-17K is inserted into an expansion slot of the PC-9800 series.  These in-circuit emulators operate as the emulator for a device when used in combination with the dedicated system evaluation board (SE board) of the device. When man-machine interface, SIMPLEHOST™, is used a sophisticated debugging environment can be realized. EMU-17K also has a function that allows real-time monitoring of the contents of the data memory.
SE board (SE-17145)	SE-17145 is an SE board for the μPD17145 subseries. It can be used alone to evaluate the system, or in combination with an in-circuit emulator for debugging.
Emulation probe (EP-17K28CT)	EP-17K28CT is an emulation probe for the 17K series 28-pin shrink DIP (400 mil).
Emulation probe (EP-17K28GT)	EP-17K28GT is an emulation probe for the 17K series 28-pin SOP (375 mil). It connects the SE board and target system when used with EV-9500GT-28 <sup>Note 3</sup> .
Conversion adapter (EV-9500GT-28 <sup>Note 3</sup> )	EV-9500GT-28 is an adapter for the 28-pin SOP (375 mil). It is used to connect EP-17K28GT and target system.
PROM programmer <sup>Note 4</sup> (AF-9703, AF-9704, AF-9705 or AF-9706)	AF-9703, AF-9704, AF-9705, and AF-9706 are PROM programmers supporting the μPD17P149. By connecting programmer adapter AF-9808M to these programmers, the μPD17P149 can be programmed.
Programmer adapter <sup>Note 4</sup> (AF-9808M)	AF-9808M is an adapter used to program the μPD17P149, in combination with AF-9703, AF-9704, AF-9705, or AF-9706.

- Notes**
1. Low-cost model: external power supply type
  2. This is a product of IC Corporation. For details, consult IC Corporation (Tokyo (03) 3447-3793).
  3. Two EV-97500GT-28s are supplied with the EP-17K28GT. Five EV-9500GT-28s are separately available as a set.
  4. These are products of Ando Electric Corporation. For details, consult Ando Electric Corporation (Tokyo (03) 3733-1151).

Software

Name	Outline	Host Machine	OS		Supply Media	Order Code
17K series assembler (AS17K)	AS17K is an assembler that can be used with any products in the 17K series. To develop the program of the μPD17145(A1), 17147(A1), and 17149(A1), the AS17K and a device file (AS17145, AS17147, or AS17149) are used in combination.	PC-9800 series	MS-DOS™		5"2HD	μS5A10AS17K
					3.5"2HD	μS5A13AS17K
		IBM PC/AT	PC DOS™		5"2HC	μS7B10AS17K
					3.5"2HC	μS7B13AS17K
Device file (AS17145, AS17147, AS17149)	AS17145, AS17147, and AS17149 are device files for the μPD17145(A1), 17147(A1), 17149(A1), and μPD17P149. They can be used in combination with the assembler for the 17K series (AS17K).	PC-9800 series	MS-DOS		5"2HD	μS5A10AS17145 <sup>Note</sup>
					3.5"2HD	μS5A13AS17145 <sup>Note</sup>
		IBM PC/AT	PC DOS		5"2HC	μS7B10AS17145 <sup>Note</sup>
					3.5"2HC	μS7B13AS17145 <sup>Note</sup>
Support software (SIMPLEHOST)	SIMPLEHOST is software that serves as man-machine interface on Windows™ when a program is developed by using an in-circuit emulator and a personal computer.	PC-9800 series	MS-DOS	Windows	5"2HD	μS5A10IE17K
			3.5"2HD		μS5A13IE17K	
		IBM PC/AT	PC DOS		5"2HC	μS7B10IE17K
					3.5"2HC	μS7B13IE17K

**Note** μSxxxxAS17145 includes AS17145, AS17147, and AS17149.

**Remark** The version of the OS supported is as follows:

OS	Version
MS-DOS	Ver. 3.30 to Ver. 5.00A <sup>Note</sup>
PC DOS	Ver. 3.1 to Ver. 5.0 <sup>Note</sup>
Windows	Ver. 3.0 to Ver. 3.1

**Note** Although MS-DOS Ver.5.00/5.00A and PC DOS Ver. 5.0 have a task swap function, this function cannot be used with this software.

## NOTES FOR CMOS DEVICES

### ① PRECAUTION AGAINST ESD FOR SEMICONDUCTORS

**Note:** Strong electric field, when exposed to a MOS device, can cause destruction of the gate oxide and ultimately degrade the device operation. Steps must be taken to stop generation of static electricity as much as possible, and quickly dissipate it once, when it has occurred. Environmental control must be adequate. When it is dry, humidifier should be used. It is recommended to avoid using insulators that easily build static electricity. Semiconductor devices must be stored and transported in an anti-static container, static shielding bag or conductive material. All test and measurement tools including work bench and floor should be grounded. The operator should be grounded using wrist strap. Semiconductor devices must not be touched with bare hands. Similar precautions need to be taken for PW boards with semiconductor devices on it.

### ② HANDLING OF UNUSED INPUT PINS FOR CMOS

**Note:** No connection for CMOS device inputs can be cause of malfunction. If no connection is provided to the input pins, it is possible that an internal input level may be generated due to noise, etc., hence causing malfunction. CMOS device behave differently than Bipolar or NMOS devices. Input levels of CMOS devices must be fixed high or low by using a pull-up or pull-down circuitry. Each unused pin should be connected to  $V_{DD}$  or  $GND$  with a resistor, if it is considered to have a possibility of being an output pin. All handling related to the unused pins must be judged device by device and related specifications governing the devices.

### ③ STATUS BEFORE INITIALIZATION OF MOS DEVICES

**Note:** Power-on does not necessarily define initial status of MOS device. Production process of MOS does not define the initial operation status of the device. Immediately after the power source is turned ON, the devices with reset function have not yet been initialized. Hence, power-on does not guarantee out-pin levels, I/O settings or contents of registers. Device is not initialized until the reset signal is received. Reset operation must be executed immediately after power-on for devices having reset function.

## Regional Information

Some information contained in this document may vary from country to country. Before using any NEC product in your application, please contact the NEC office in your country to obtain a list of authorized representatives and distributors. They will verify:

- Device availability
- Ordering information
- Product release schedule
- Availability of related technical literature
- Development environment specifications (for example, specifications for third-party tools and components, host computers, power plugs, AC supply voltages, and so forth)
- Network requirements

In addition, trademarks, registered trademarks, export restrictions, and other legal issues may also vary from country to country.

### **NEC Electronics Inc. (U.S.)**

Santa Clara, California  
Tel: 408-588-6000  
800-366-9782  
Fax: 408-588-6130  
800-729-9288

### **NEC Electronics (Germany) GmbH**

Duesseldorf, Germany  
Tel: 0211-65 03 02  
Fax: 0211-65 03 490

### **NEC Electronics (UK) Ltd.**

Milton Keynes, UK  
Tel: 01908-691-133  
Fax: 01908-670-290

### **NEC Electronics Italiana s.r.l.**

Milano, Italy  
Tel: 02-66 75 41  
Fax: 02-66 75 42 99

### **NEC Electronics (Germany) GmbH**

Benelux Office  
Eindhoven, The Netherlands  
Tel: 040-2445845  
Fax: 040-2444580

### **NEC Electronics (France) S.A.**

Velizy-Villacoublay, France  
Tel: 01-30-67 58 00  
Fax: 01-30-67 58 99

### **NEC Electronics (France) S.A.**

Spain Office  
Madrid, Spain  
Tel: 01-504-2787  
Fax: 01-504-2860

### **NEC Electronics (Germany) GmbH**

Scandinavia Office  
Taeby, Sweden  
Tel: 08-63 80 820  
Fax: 08-63 80 388

### **NEC Electronics Hong Kong Ltd.**

Hong Kong  
Tel: 2886-9318  
Fax: 2886-9022/9044

### **NEC Electronics Hong Kong Ltd.**

Seoul Branch  
Seoul, Korea  
Tel: 02-528-0303  
Fax: 02-528-4411

### **NEC Electronics Singapore Pte. Ltd.**

United Square, Singapore 1130  
Tel: 253-8311  
Fax: 250-3583

### **NEC Electronics Taiwan Ltd.**

Taipei, Taiwan  
Tel: 02-719-2377  
Fax: 02-719-5951

### **NEC do Brasil S.A.**

Cumbica-Guarulhos-SP, Brasil  
Tel: 011-6465-6810  
Fax: 011-6465-6829

**SIMPLEHOST is a trademark of NEC Corporation.**

**MS-DOS and Windows are either registered trademarks or trademarks of Microsoft Corporation in the United States and/or other countries.**

**PC/AT and PC DOS are trademarks of IBM Corporation.**

The export of this product from Japan is regulated by the Japanese government. To export this product may be prohibited without governmental license, the need for which must be judged by the customer. The export or re-export of this product from a country other than Japan may also be prohibited without a license from that country. Please call an NEC sales representative.

No part of this document may be copied or reproduced in any form or by any means without the prior written consent of NEC Corporation. NEC Corporation assumes no responsibility for any errors which may appear in this document.

NEC Corporation does not assume any liability for infringement of patents, copyrights or other intellectual property rights of third parties by or arising from use of a device described herein or any other liability arising from use of such device. No license, either express, implied or otherwise, is granted under any patents, copyrights or other intellectual property rights of NEC Corporation or others.

While NEC Corporation has been making continuous effort to enhance the reliability of its semiconductor devices, the possibility of defects cannot be eliminated entirely. To minimize risks of damage or injury to persons or property arising from a defect in an NEC semiconductor device, customers must incorporate sufficient safety measures in its design, such as redundancy, fire-containment, and anti-failure features.

NEC devices are classified into the following three quality grades:

"Standard", "Special", and "Specific". The Specific quality grade applies only to devices developed based on a customer designated "quality assurance program" for a specific application. The recommended applications of a device depend on its quality grade, as indicated below. Customers must check the quality grade of each device before using it in a particular application.

Standard: Computers, office equipment, communications equipment, test and measurement equipment, audio and visual equipment, home electronic appliances, machine tools, personal electronic equipment and industrial robots

Special: Transportation equipment (automobiles, trains, ships, etc.), traffic control systems, anti-disaster systems, anti-crime systems, safety equipment and medical equipment (not specifically designed for life support)

Specific: Aircrafts, aerospace equipment, submersible repeaters, nuclear reactor control systems, life support systems or medical equipment for life support, etc.

The quality grade of NEC devices is "Standard" unless otherwise specified in NEC's Data Sheets or Data Books. If customers intend to use NEC devices for applications other than those specified for Standard quality grade, they should contact an NEC sales representative in advance.

Anti-radioactive design is not implemented in this product.