



PARA LIGHT ELECTRONICS CO., LTD.

4F, No.1, Lane 93, Chien Yi Road, Chung Ho City, Taipei, Taiwan

Tel: 886-2-2225-3733

Fax: 886-2-2225-4800

E-mail: para@para.com.tw

<http://www.para.com.tw>

DATA SHEET

PART NO. : EP501W1C001WH

REV : A/4

CUSTOMER'S APPROVAL : _____

DCC : _____



Enhance Power LED

EP501W1C001WH

REV:A/4

●Package Dimension

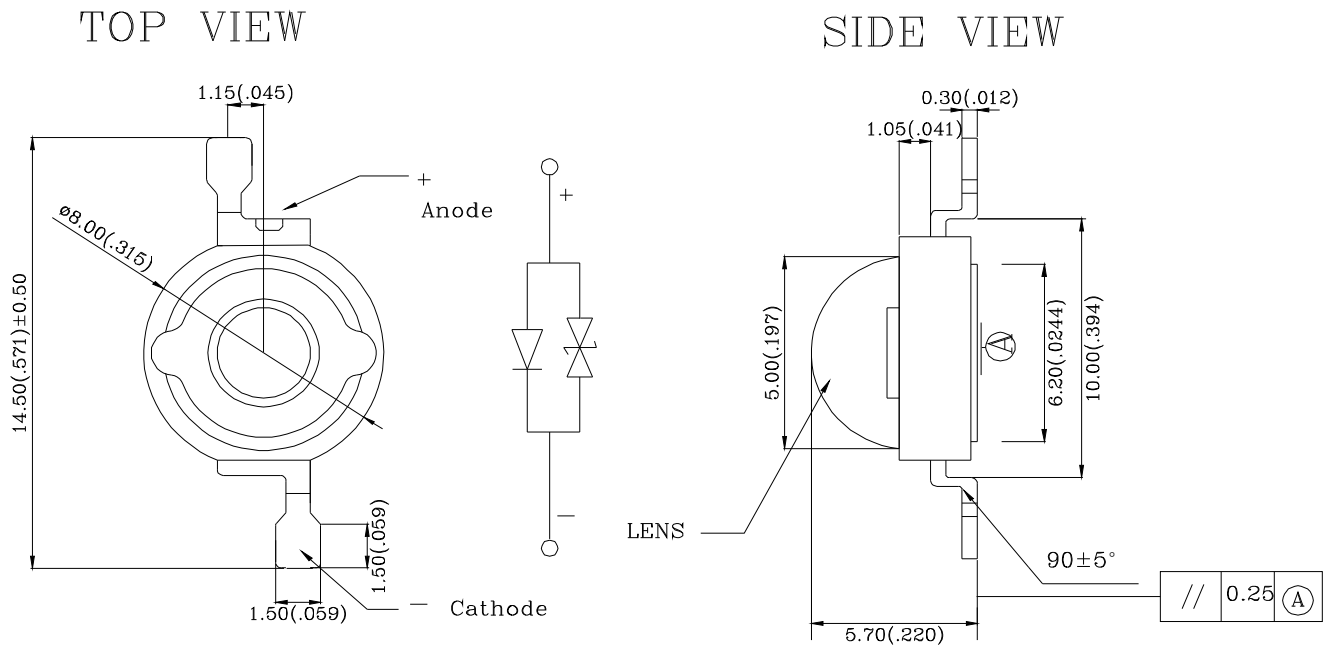

Note:

1. All dimensions are in millimeters.
2. Tolerance is $\pm 0.25\text{mm}$ (.010") unless otherwise noted.

●Features

1. Long operating life.
2. Low voltage DC operated.
3. Instant light (Less than 100NS).
4. RoHS Compliant.
5. Compatible to assemble, lead free reflow soldering process.
6. No UV emission.
7. The led can withstand the max static level when assembling or operation (HBM)

	Enhance Power LED
	EP501W1C001WH REV:A/4

●Chip Material

1. Dice Material : InGaN
2. Light Color : White
3. Lens Color : Water Clear

●Absolute Maximum Rating(Ta=25°C)

Symbol	Parameter	Rating	Unit
IF	DC Forward Current	350	mA
Ipulse	Peak Pulse Current (tp ≤ 100us, duty cycle=0.25)	500	mA
VR	Reverse Voltage	5	V
IR	Reverse Current(VR=5V)	50	uA
Tj	LED Junction Temperature(at IF=350mA)	115	°C
*Topr	Operating Temperature	-30 ~ +100	°C
*Tstg	Storage Temperature	-40 ~ +100	°C
Tsol	Manual Soldering Time at 260°C (Max.)	5	seconds
ESD	ESD Sensitivity (Human Body Model)	2000	V

Note :

* : Temperature for using with aluminum board.

●Electro-Optical Characteristic(Ta=25°C , Topr=100ms)

Parameter	Symbol	Min.	Typ.	Max.	Unit	Test Condition
Luminous Flux	ΦV	95	110		lm	IF=350mA
Viewing Angle	2θ1/2		60		deg	
Color Temperature	CCT		6000		K	IF=350mA
Forward Voltage	VF		3.3	3.6	V	IF =350mA
Reverse Current	IR			50	μA	VR = 5V



Enhance Power LED

EP501W1C001WH

REV:A/4

• Typical Optical and Electrical

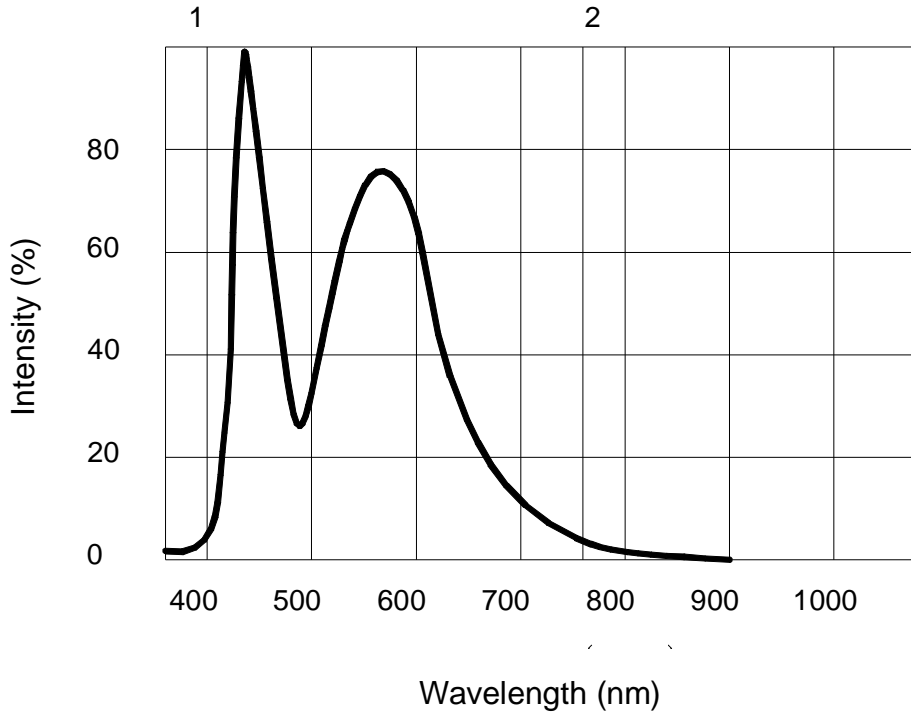

Relative Intensity VS Wavelength

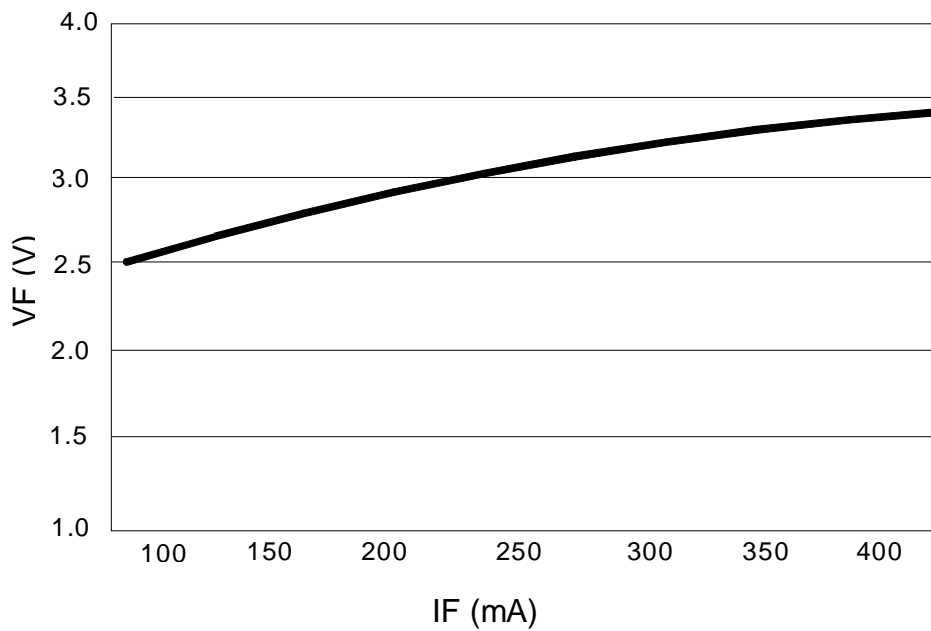

Forward Current VS Forward Voltage



Enhance Power LED

EP501W1C001WH

REV:A/4

• Typical Optical and Electrical

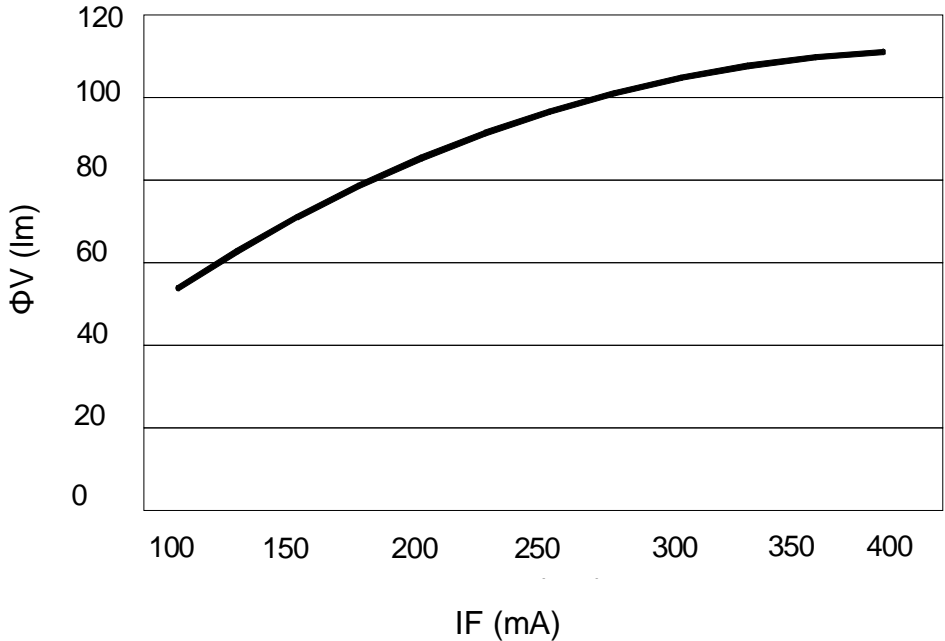

Forward Current VS Luminous Flux

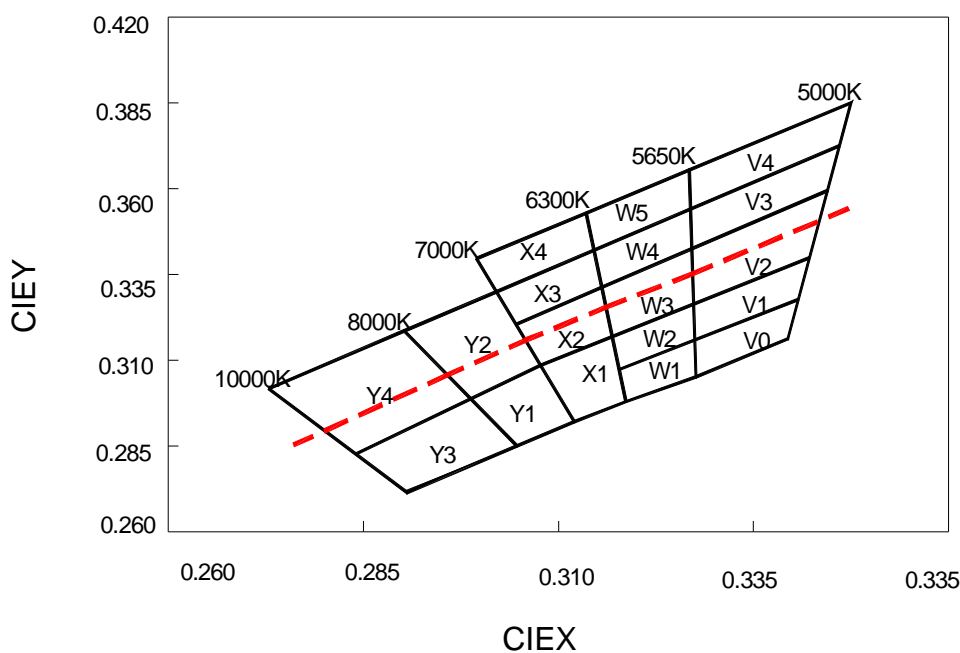

Cool-white Bin Structure



Enhance Power LED

EP501W1C001WH

REV:A/4

Group/ CCT(Typ)	X	Y	Group/ CCT(Typ)	X	Y
V0 5300K	0.34335	0.33203	W1 6000K	0.32939	0.32021
	0.34250	0.32080		0.32954	0.31050
	0.32954	0.31050		0.31960	0.30130
	0.32939	0.32002		0.31861	0.31020
V1 5300K	0.32922	0.33133	W2 6000K	0.32922	0.33133
	0.34444	0.34423		0.32939	0.32021
	0.34335	0.33203		0.31861	0.31020
	0.32939	0.32002		0.31747	0.32044
V2 5300K	0.32922	0.33133	W3 6000K	0.32901	0.34509
	0.32901	0.34509		0.32922	0.33133
	0.34578	0.35919		0.31747	0.32044
	0.34444	0.34423		0.31604	0.33322
V3 5300K	0.32901	0.34509	W4 6000K	0.32901	0.34509
	0.32882	0.35692		0.31604	0.33322
	0.34690	0.37174		0.31479	0.34444
	0.34578	0.35919		0.32882	0.35692
V4 5300K	0.32882	0.35692	W5 6000K	0.31479	0.34444
	0.32864	0.36895		0.31362	0.35499
	0.34815	0.38563		0.32864	0.36895
	0.34690	0.37174		0.32882	0.35692

Group/ CCT(Typ)	X	Y	Group/ CCT(Typ)	X	Y
X1 6650K	0.30755	0.31078	Y1 7500K	0.30400	0.28500
	0.31745	0.32044		0.29900	0.30100
	0.31960	0.30130		0.30755	0.31078
	0.31116	0.29319		0.31116	0.29319
X2 6650K	0.30755	0.31078	Y2 7500K	0.29900	0.30100
	0.30517	0.32239		0.29200	0.32100
	0.34335	0.33322		0.30305	0.33271
	0.31747	0.32044		0.30755	0.31078
X3 6650K	0.30517	0.32239	Y3 9000K	0.30400	0.28500
	0.30305	0.33271		0.28992	0.27032
	0.31479	0.34444		0.28297	0.27032
	0.31604	0.33322		0.29900	0.30100
X4 6650K	0.30305	0.33271	Y4 9000K	0.29200	0.32100
	0.30109	0.34224		0.27424	0.30067
	0.30109	0.34224		0.28297	0.28377
	0.31479	0.34444		0.29900	0.30100



Enhance Power LED

EP501W1C001WH

REV:A/4

Typical Optical and Electrical

typical polar radiation pattern for lambertian

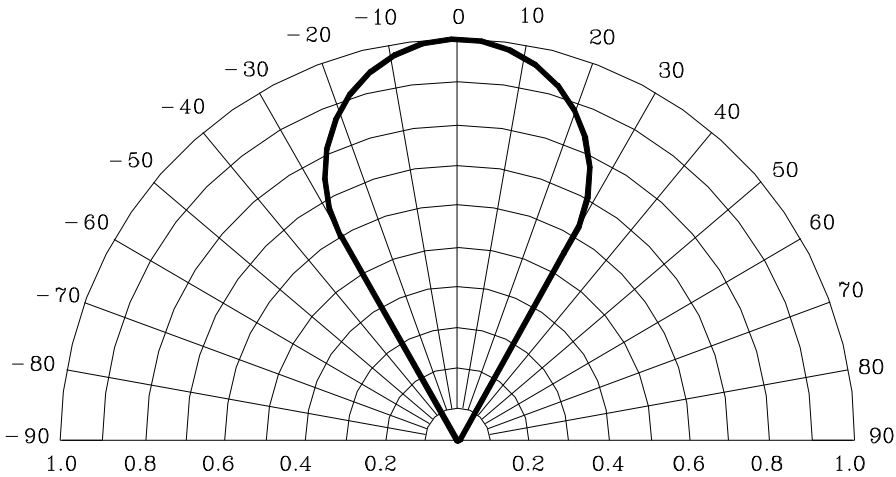

•Bin Code List

Luminous Flux (Φ_V),(Unit: lm ,IF=350mA)		
Bin Code	Min	Max
R	95	100
S	100	110
T	110	120
U	120	130

Including test tolerance $\pm 10\%$

Forward Voltage(VF),(Unit: V, IF=350mA)		
Bin Code	Min	Max
V8	3.00	3.20
V9	3.20	3.40
V10	3.40	3.60

Including test tolerance $\pm 0.1V$



Enhance Power LED

EP501W1C001WH

REV:A/4

●Label Explanation

P/N: _____ EP501W1C001WH
 QTY: _____ XXXX _____ PCS
 LOT NO.: _____ LEM1001001
 BIN NO.: _____ S/W3/6000/V9

PART NO: EP501W1C001WH

LOT NO: L E M 10 1 001
 A B C D E F

A---L: Local F: Foreign

B---E: E-power

C---M: For series number

D---Year

E---Month

F---Spec.

BIN NO: Bin Code

●Caution

(1).Handling note: Do not touch LED's lens.

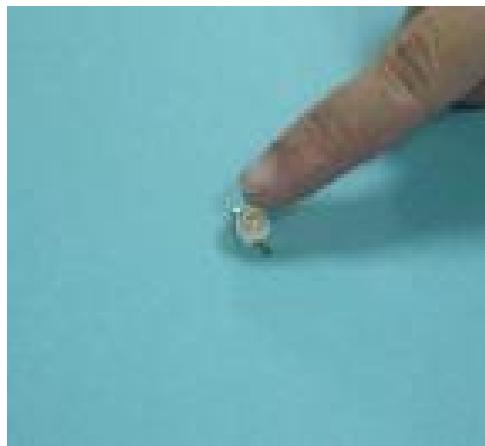



Enhance Power LED

EP501W1C001WH

REV:A/4

(2) Please wear anti-static wrist strap and gloves to prevent ESD damage when handling.



●Packing Specification

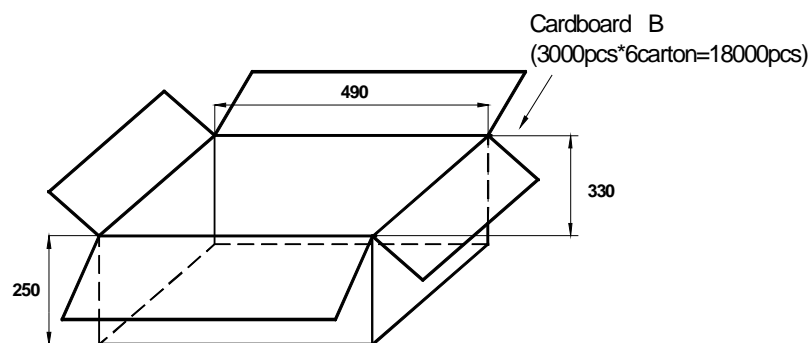
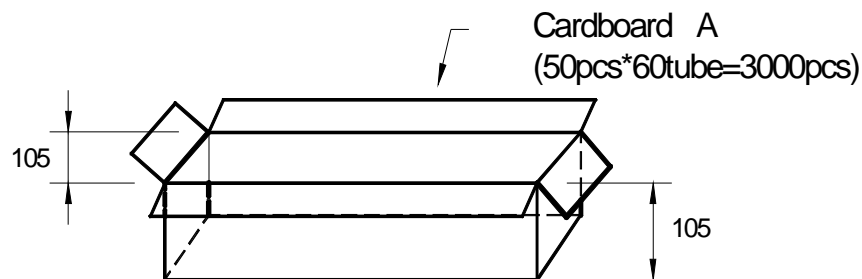
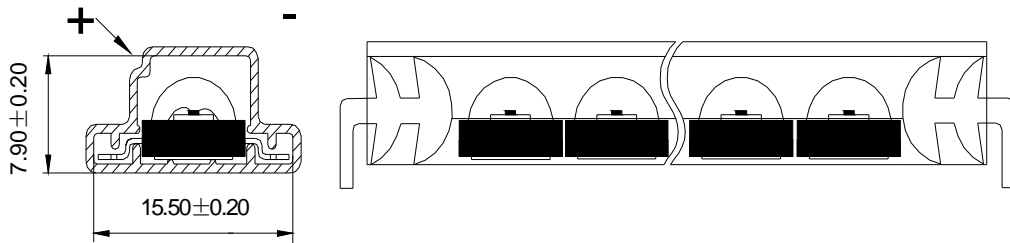

Note:

1. All dimensions are in millimeters.
2. Normal packing Quantity:3000pcs.
3. The carton B contains 6 cartons A at maximum.



Enhance Power LED

EP501W1C001WH

REV: A/4

●Suggest Soldering Pad Dimension

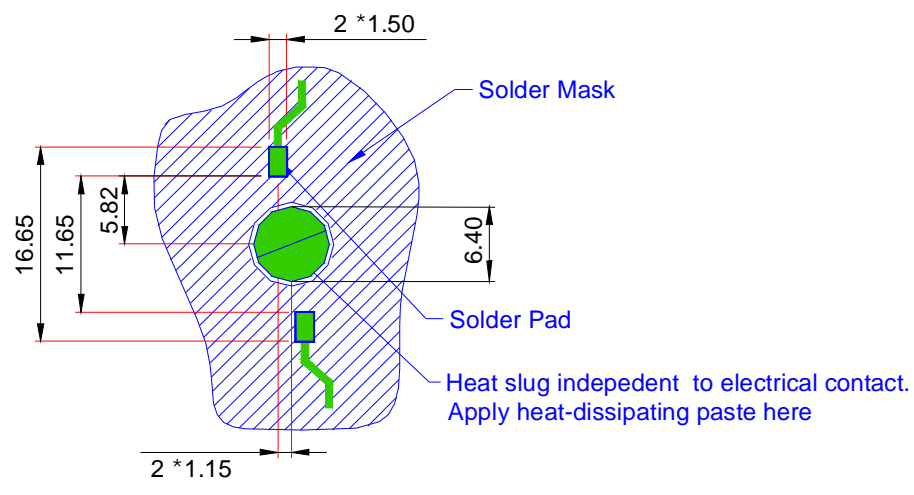

Note:

1. All dimensions are in millimeters.
2. The drawings are not to scale.
3. Solder pad can't be connected to slug.

●IR Reflow soldering profile for lead free soldering(J-STD-020C)

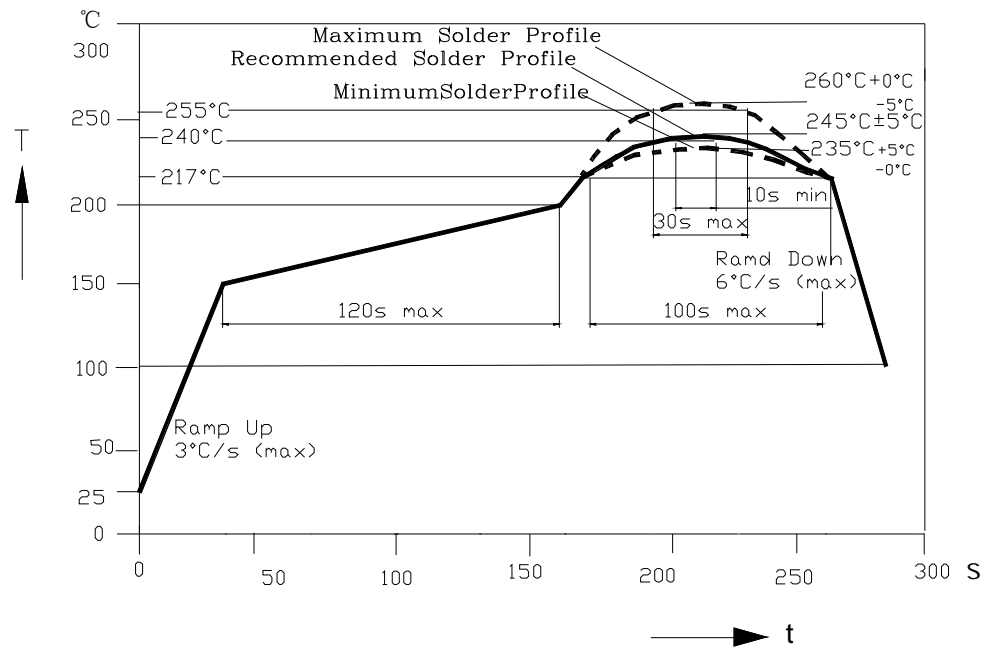



Enhance Power LED

EP501W1C001WH

REV:A/4

●Storage

1. Do not open the moisture proof bag before the devices are ready to use.
2. Before the package is opened, LED should be stored at temperatures less than 30°C and humidity less than 50%.
3. LED may be stored for 6 months. When the storage time has reached more than 6 months, LED should be stored in a sealed container filled with Nitrogen gas.
4. After the package is opened, LED should be stored at temperatures less than 30°C and humidity less than 30%.
5. LED should be used within 168 hours (7 days) after the package is opened.
6. Before using LED, baking treatment should be implemented based on the following condition: pre-curing at 60±5°C for 24 hours.

●E-Power Operating Procedure

1. E-power 350 series products should be operated at 350 mA for ideal performance, but not more than 350mA.
2. E-power 350 series products must be used in conjunction with heat-sinking devices. Soldering on Al PCB with mid-connection point while keeping the layout pattern (∅ 19.9mm, thickness 2.5mm) is another way to help heat dissipation. Thermal Resistance for aluminum board must be less than 0.65 °C/W.
3. E-power 350 series products are sensitive to static. Operators must wear static wristband (wireless static wristband is prohibited) and be well grounded while working in the environment with an ionizing air blower. Anti-static requirement should be under ESD 2000V.
4. A non-conductive heat-dissipating paste should be applied between E-power and heat-sinking device.
5. Sufficient thermal management must be applied. Large LED forward current will cause high junction temperature and reduce LED life.



Enhance Power LED

EP501W1C001WH

REV:A/4

●Reliability Test

Test Item	number	Test Condition	Stress duration	result
Reflow	100pcs	Tsol=260°C,10sec	3 times	No Failure
Temperature Cycle	20pcs	H:+100±5°C 15mins L: -40±5°C	300 Cycles	No Failure
High Temperature High Humidity Operation	20pcs	Ta=85°C±5°C RH= 90~95% IF=350mA	500 hours	No Failure
High Temperature High Humidity Storage	20pcs	Ta:65°C±5°C RH:90~95%RH	1000hours	No Failure
Room Temperature Operation	20pcs	Ta= 25±5°C IF =350mA	1000hours	No Failure
Low Temperature Operation	20pcs	Ta= -40±5°C IF=350mA	1000hours	No Failure
High Temperature Operation	20pcs	Ta= 110±5°C IF=350mA	1000hours	No Failure
Salt Spray	20pcs	Ta=35°C	48 hours	No Failure

Temperature for using with aluminum board, in a good thermal-exchange surrounding.

Failure Criteria:

1. LED are open or shorted,
2. Luminous flux attenuate difference(1000hours)> 30%,
3. Forward voltage difference(1000hours) > 20%.



Enhance Power LED

EP501W1C001WH

REV:A/4

● Part NO. System of E-Power LED

EP 5 01 W1 C 001 W H

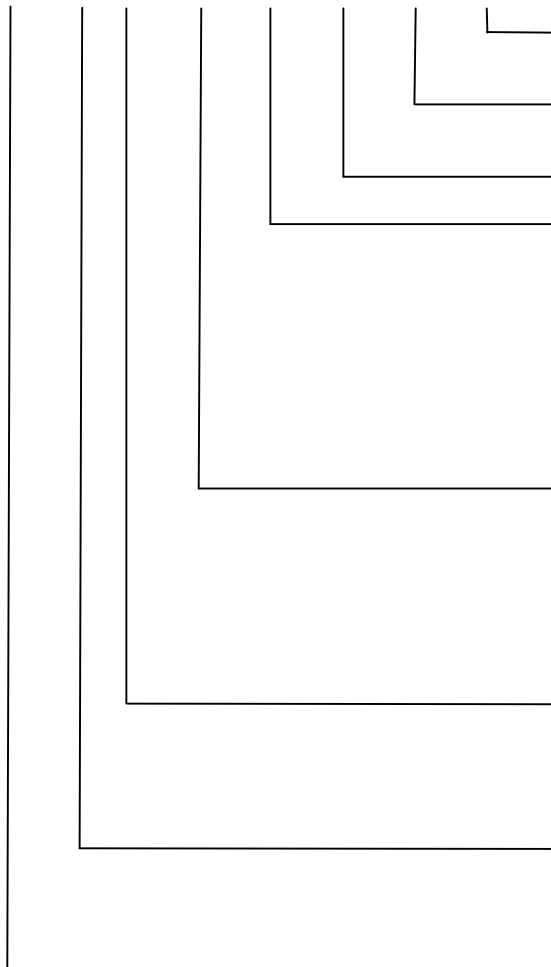

H: High luminance
Special mark: W:white, B:black
Series Number
View Angle: 2: 2*5=10° L: L*5=130° 3: 3*5=15° M: M*5=160° 6 : 6*5=30°
R1: λ d=625nm Y1: λ d=590nm G1: λ d=525nm B1: λ d= 460nm IR: λ p=850nm A1: λ d=615nm W1: white WY: warm white
Power: 01—1W , 03—3W , 05—5W,..... 0A-100W
Slug material: 1—Al,2—silicon,3—Fe,4—ceramic, 5—Cu
EP: Enhance Power