

**Product Features**

- Near-zero propagation delay
- 5W switches connect inputs to outputs
- Direct bus connection when switches are ON
- Ultra-low quiescent power (0.2μA typical)
  - Ideally suited for notebook applications
- Industrial operating temperature: -40°C to +85°C
- Available Packages:
  - 48-pin 240-mil wide thin plastic TSSOP (A)
  - 48-pin 300-mil wide plastic SSOP (V)

**Product Description**

Pericom Semiconductor’s PI5C series of logic circuits are produced using the Company’s advanced 0.8 micron CMOS technology.

The PI5C16209 and PI5C162209 are 18-bit bus exchange switches designed with a low ON resistance (5Ω) allowing inputs to be connected directly to outputs. This device operates as a 18-bit bus switch or a 9-bit exchanger, which provides data exchanging between the four signal ports via the data select pins (S0-S2).

The PI5C162209 device has a built-in 25-ohm series resistor to reduce noise because of reflections, thus eliminating the need for an external terminating resistor.

**Logic Block Diagram**

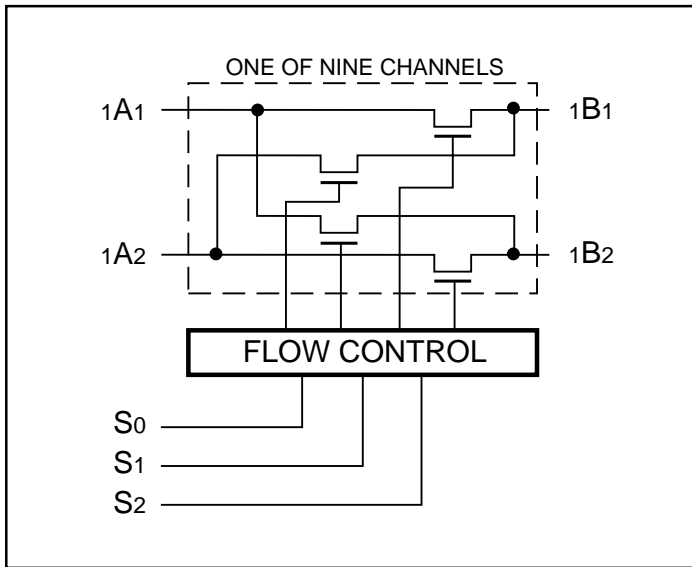

**Product Pin Configuration**

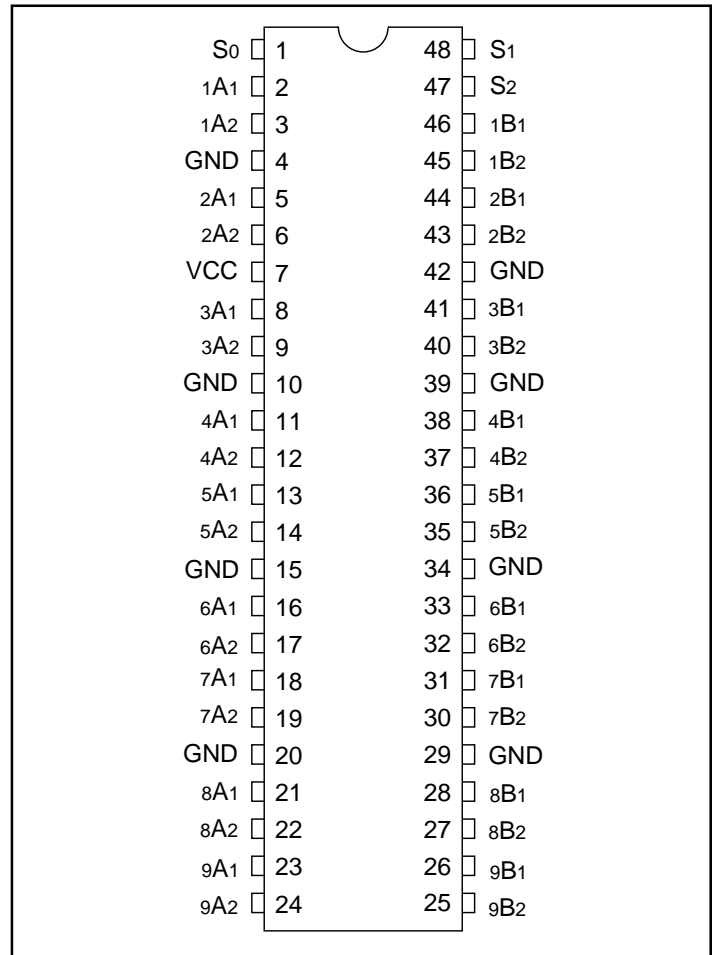

**Truth Table**

Function	S2	S1	S0	A1	A2
Disconnect	L	L	L	Z	Z
A1 to B1	L	L	H	B1	Z
A1 to B2	L	H	L	B2	Z
A2 to B1	L	H	H	Z	B1
A2 to B2	H	L	L	Z	B2
Disconnect	H	L	H	Z	Z
A1 to B1, A2 to B2	H	H	L	B1	B2
A1 to B2, A2 to B1	H	H	H	B2	B1

**Note:** 1. H = High Voltage Level  
 L = Low Voltage Level  
 Z = High Impedance

**Product Pin Description**

Pin Name	I/O	Description
S0-S2	I	Select Inputs
xAx	I/O	Bus A
xBx	I/O	Bus B

### Maximum Ratings

(Above which the useful life may be impaired. For user guidelines, not tested.)

Storage Temperature .....	-65°C to +150°C
Ambient Temperature with Power Applied .....	-40°C to +85°C
Supply Voltage to Ground Potential (Inputs & V <sub>CC</sub> Only) .....	-0.5V to +7.0V
Supply Voltage to Ground Potential (Outputs & D/O Only) ....	-0.5V to +7.0V
DC Input Voltage .....	-0.5V to +7.0V
DC Output Current .....	120mA
Power Dissipation .....	0.5W

**Note:**

Stresses greater than those listed under MAXIMUM RATINGS may cause permanent damage to the device. This is a stress rating only and functional operation of the device at these or any other conditions above those indicated in the operational sections of this specification is not implied. Exposure to absolute maximum rating conditions for extended periods may affect reliability.

### DC Electrical Characteristics (Over the Operating Range, T<sub>A</sub> = -40°C to +85°C, V<sub>CC</sub> = 5V ±5%)

Parameters	Description	Test Conditions <sup>(1)</sup>	Min.	Typ <sup>(2)</sup>	Max.	Units	
V <sub>IH</sub>	Input HIGH Voltage	Guaranteed Logic HIGH Level	2.0	—	—	V	
V <sub>IL</sub>	Input LOW Voltage	Guaranteed Logic LOW Level	-0.5	—	0.8	V	
I <sub>IH</sub>	Input HIGH Current	V <sub>CC</sub> = Max., V <sub>IN</sub> = V <sub>CC</sub>	—	—	±1	µA	
I <sub>IL</sub>	Input LOW Current	V <sub>CC</sub> = Max., V <sub>IN</sub> = GND	—	—	±1	µA	
I <sub>OZH</sub>	High Impedance Output Current	0 ≤ A, B ≤ V <sub>CC</sub>	—	—	±1	µA	
V <sub>IK</sub>	Clamp Diode Voltage	V <sub>CC</sub> = Min., I <sub>IN</sub> = -18mA	—	-0.7	-1.2	V	
I <sub>OS</sub>	Short Circuit Current <sup>(3)</sup>	A (B) = 0V, B (A) = V <sub>CC</sub>	100	—	—	mA	
V <sub>H</sub>	Input Hysteresis at Control Pins		—	150	—	mV	
R <sub>ON</sub>	Switch On Resistance <sup>(4)</sup>	V <sub>CC</sub> = Min., V <sub>IN</sub> = 0.0V, I <sub>ON</sub> = 48mA	16209	—	5	7	Ω
			162209	20	28	40	
		V <sub>CC</sub> = Min., V <sub>IN</sub> = 2.4V, I <sub>ON</sub> = 15mA	16209	—	10	15	Ω
			162209	20	35	48	

### Capacitance (T<sub>A</sub> = 25°C, f = 1 MHz)

Parameters <sup>(5)</sup>	Description	Test Conditions	Typ	Max.	Units
C <sub>IN</sub>	Input Capacitance	V <sub>IN</sub> = 0V	—	6	pF
C <sub>OFF</sub>	A/B Capacitance, Switch Off	V <sub>IN</sub> = 0V	—	6	pF
C <sub>ON</sub>	A/B Capacitance, Switch On	V <sub>IN</sub> = 0V	—	8	pF

**Notes:**

1. For Max. or Min. conditions, use appropriate value specified under Electrical Characteristics for the applicable device type.
2. Typical values are at V<sub>CC</sub> = 5.0V, T<sub>A</sub> = 25°C ambient and maximum loading.
3. Not more than one output should be shorted at one time. Duration of the test should not exceed one second.
4. Measured by the voltage drop between A and B pin at indicated current through the switch. ON resistance is determined by the lower of the voltages on the two (A,B) pins.
5. This parameter is determined by device characterization but is not production tested.

**Power Supply Characteristics**

Parameters	Description	Test Conditions <sup>(1)</sup>		Min.	Typ <sup>(2)</sup>	Max.	Units
I <sub>CC</sub>	Quiescent Power Supply Current	V <sub>CC</sub> = Max.	V <sub>IN</sub> = GND or V <sub>CC</sub>	—	0.1	3.0	μA
ΔI <sub>CC</sub>	Supply Current per Input @ TTL HIGH	V <sub>CC</sub> = Max.	V <sub>IN</sub> = 3.4V <sup>(3)</sup>	—	—	2.5	mA
I <sub>CCD</sub>	Supply Current per Input per MHz <sup>(4)</sup>	V <sub>CC</sub> = Max., A and B Pins Open S <sub>n</sub> = GND Control Input Toggling 50% Duty Cycle		—	—	0.25	mA/ MHz

**Notes:**

- For conditions shown as Max. or Min., use appropriate value specified under Electrical Characteristics for the applicable device.
- Typical values are at V<sub>CC</sub> = 5.0V, +25°C ambient.
- Per TTL driven input (V<sub>IN</sub> = 3.4V, control inputs only); A and B pins do not contribute to I<sub>CC</sub>.
- This current applies to the control inputs only and represent the current required to switch internal capacitance at the specified frequency. The A and B inputs generate no significant AC or DC currents as they transition. This parameter is not tested, but is guaranteed by design.

**PI5C16209 Switching Characteristics over Operating Range**

Parameters	Description	Conditions <sup>(1)</sup>	PI5C16209		Units
			Com.		
			Min	Max	
t <sub>PLH</sub> t <sub>PHL</sub>	Propagation Delay <sup>(2,3)</sup> xAx to xBx, xBx to xAx	C <sub>L</sub> = 50pF R <sub>L</sub> = 500Ω	—	0.25	ns
t <sub>PZH</sub> t <sub>PZL</sub>	Bus Enable Time S to xAx or xBx		1.5	6.5	
t <sub>PHZ</sub> t <sub>PLZ</sub>	Bus Disable Time S to xAx or xBx		1.5	5.5	

**PI5C162209 Switching Characteristics over Operating Range**

Parameters	Description	Conditions <sup>(1)</sup>	PI5C162209		Units
			Com.		
			Min	Max	
t <sub>PLH</sub> t <sub>PHL</sub>	Propagation Delay <sup>(2,3)</sup> xAx to xBx, xBx to xAx	C <sub>L</sub> = 50pF R <sub>L</sub> = 500Ω	—	1.25	ns
t <sub>PZH</sub> t <sub>PZL</sub>	Bus Enable Time S to xAx or xBx		1.5	6.5	
t <sub>PHZ</sub> t <sub>PLZ</sub>	Bus Disable Time S to xAx or xBx		1.5	5.5	

**Notes:**

- See test circuit and waveforms.
- This parameter is guaranteed but not tested on Propagation Delays.
- The bus switch contributes no propagational delay other than the RC delay of the ON resistance of the switch and the load capacitance. The time constant for the switch alone is of the order of 0.25ns for 50pF load. Since this time constant is much smaller than the rise/fall times of typical driving signals, it adds very little propagational delay to the system. Propagational delay of the bus switch when used in a system is determined by the driving circuit on the driving side of the switch and its interaction with the load on the driven side.