

## FEATURES

- High level of integration—only one power semiconductor module required for the whole drive
- Low saturation voltage and positive temperature coefficient
- Fast switching and short tail current
- Free wheeling diodes with fast and soft reverse recovery
- Industry standard package with insulated copper base plate and soldering pins for PCB mounting
- Temperature sense included

## APPLICATIONS

- AC motor control
- Motion/servo control
- Inverter and power supplies



**PIM Three Phase Input Rectifier**

## INVERTER SECTOR

### ABSOLUTE MAXIMUM RATINGS

*T<sub>c</sub>=25°C unless otherwise specified*

Symbol	Parameter	Test Conditions	Values	Unit
<b>IGBT</b>				
V <sub>CES</sub>	Collector - Emitter Voltage	T <sub>vj</sub> =25°C	1200	V
V <sub>GES</sub>	Gate - Emitter Voltage		±20	V
I <sub>c</sub>	DC Collector Current	T <sub>c</sub> =25°C	55	A
		T <sub>c</sub> =80°C	40	A
I <sub>CM</sub>	Repetitive Peak Collector Current	t <sub>p</sub> =1ms	80	A
P <sub>tot</sub>	Power Dissipation Per IGBT		195	W
<b>Diode</b>				
V <sub>R RM</sub>	Repetitive Reverse Voltage	T <sub>vj</sub> =25°C	1200	V
I <sub>F(AV)</sub>	Average Forward Current	T <sub>c</sub> =25°C	55	A
		T <sub>c</sub> =80°C	40	A
I <sub>FRM</sub>	Repetitive Peak Forward Current	t <sub>p</sub> =1ms	80	A
I <sup>2</sup> t		T <sub>vj</sub> =125°C, t=10ms, V <sub>R</sub> =0V	300	A <sup>2</sup> s

**INVERTER SECTOR**

**ELECTRICAL AND THERMAL CHARACTERISTICS** *T<sub>C</sub>=25°C unless otherwise specified*

Symbol	Parameter	Test Conditions	Min.	Typ.	Max.	Unit
<b>IGBT</b>						
V <sub>GE(th)</sub>	Gate - Emitter Threshold Voltage	V <sub>CE</sub> =V <sub>GE</sub> , I <sub>C</sub> =1.5mA	5.0	5.8	6.5	V
V <sub>CE(sat)</sub>	Collector - Emitter Saturation Voltage	I <sub>C</sub> =40A, V <sub>GE</sub> =15V, T <sub>VJ</sub> =25°C		1.8		V
		I <sub>C</sub> =40A, V <sub>GE</sub> =15V, T <sub>VJ</sub> =125°C		2.05		V
I <sub>CEs</sub>	Collector Leakage Current	V <sub>CE</sub> =1200V, V <sub>GE</sub> =0V, T <sub>VJ</sub> =25°C			0.25	mA
		V <sub>CE</sub> =1200V, V <sub>GE</sub> =0V, T <sub>VJ</sub> =125°C			2	mA
I <sub>GES</sub>	Gate Leakage Current	V <sub>CE</sub> =0V, V <sub>GE</sub> ± 15V, T <sub>VJ</sub> =125°C	-400		400	nA
R <sub>Gint</sub>	Integrated Gate Resistor			6.0		Ω
Q <sub>ge</sub>	Gate Charge	V <sub>CE</sub> =600V, I <sub>C</sub> =40A, V <sub>GE</sub> = ± 15V		0.33		μC
C <sub>ies</sub>	Input Capacitance	V <sub>CE</sub> =25V, V <sub>GE</sub> =0V, f = 1MHz		2.5		nF
C <sub>res</sub>	Reverse Transfer Capacitance			0.11		nF
t <sub>d(on)</sub>	Turn - on Delay Time	V <sub>CC</sub> =600V, I <sub>C</sub> =40A, R <sub>G</sub> = 27 Ω ,	T <sub>VJ</sub> = 25°C	90		ns
			T <sub>VJ</sub> = 125°C	90		ns
t <sub>r</sub>	Rise Time	V <sub>GE</sub> = ± 15V, Inductive Load	T <sub>VJ</sub> = 25°C	30		ns
			T <sub>VJ</sub> = 125°C	50		ns
t <sub>d(off)</sub>	Turn - off Delay Time	V <sub>CC</sub> =600V, I <sub>C</sub> =40A, R <sub>G</sub> = 27 Ω ,	T <sub>VJ</sub> = 25°C	420		ns
			T <sub>VJ</sub> = 125°C	520		ns
t <sub>f</sub>	Fall Time	V <sub>GE</sub> = ± 15V, Inductive Load	T <sub>VJ</sub> = 25°C	70		ns
			T <sub>VJ</sub> = 125°C	90		ns
E <sub>on</sub>	Turn - on Energy	V <sub>CC</sub> =600V, I <sub>C</sub> =40A, R <sub>G</sub> = 27 Ω ,	T <sub>VJ</sub> = 25°C	4.1		mJ
			T <sub>VJ</sub> = 125°C	5.8		mJ
E <sub>off</sub>	Turn - off Energy	V <sub>GE</sub> = ± 15V, Inductive Load	T <sub>VJ</sub> = 25°C	3.6		mJ
			T <sub>VJ</sub> = 125°C	4.2		mJ
I <sub>sc</sub>	Short Circuit Current	t <sub>psc</sub> ≤ 10μS, V <sub>GE</sub> =15V T <sub>VJ</sub> =125°C, V <sub>CC</sub> =900V		160		A
R <sub>thJC</sub>	Junction-to-Case Thermal Resistance ( Per IGBT )				0.64	K /W
<b>Diode</b>						
V <sub>F</sub>	Forward Voltage	I <sub>F</sub> =40A, V <sub>GE</sub> =0V, T <sub>VJ</sub> = 25°C		1.80		V
		I <sub>F</sub> =40A, V <sub>GE</sub> =0V, T <sub>VJ</sub> = 125°C		1.85		V
t <sub>rr</sub>	Reverse Recovery Time	I <sub>F</sub> =40A, V <sub>R</sub> =600V		240		ns
I <sub>RRM</sub>	Max. Reverse Recovery Current	di <sub>F</sub> /dt=-400A/μs		35		A
E <sub>rec</sub>	Reverse Recovery Energy	T <sub>VJ</sub> = 125°C		2.8		mJ
R <sub>thJCD</sub>	Junction-to-Case Thermal Resistance ( Per Diode )				1.0	K /W

**DIODE-RECTIFIER SECTOR**

**ABSOLUTE MAXIMUM RATINGS**

*T<sub>C</sub>=25°C unless otherwise specified*

Symbol	Parameter	Test Conditions	Values	Unit
V <sub>RRM</sub>	Repetitive Reverse Voltage	T <sub>Vj</sub> =25°C	1600	V
I <sub>F(AV)</sub>	Average Forward Current	T <sub>C</sub> =80°C	40	A
I <sub>FSM</sub>	Non-Repetitive Surge Forward Current	T <sub>Vj</sub> =45°C, t=10ms, 50Hz	320	A
		T <sub>Vj</sub> =45°C, t=8.3ms, 60Hz	350	A
I <sup>2</sup> t		T <sub>Vj</sub> =45°C, t=10ms, 50Hz	512	A <sup>2</sup> s
		T <sub>Vj</sub> =45°C, t=8.3ms, 60Hz	612	A <sup>2</sup> s

**DIODE-RECTIFIER SECTOR**

**ELECTRICAL AND THERMAL CHARACTERISTICS**

*T<sub>C</sub>=25°C unless otherwise specified*

Symbol	Parameter	Test Conditions	Min.	Typ.	Max.	Unit
V <sub>F</sub>	Forward Voltage	I <sub>F</sub> =40A , T <sub>Vj</sub> =25°C		1.2		V
		I <sub>F</sub> =40A , T <sub>Vj</sub> =125°C		1.15		V
I <sub>R</sub>	Reverse Leakage Current	V <sub>R</sub> =1600V, T <sub>Vj</sub> =25°C			50	μA
		V <sub>R</sub> =1600V, T <sub>Vj</sub> =125°C			1	mA
R <sub>thJCD</sub>	Junction-to-Case Thermal Resistance ( Per Diode )				1.0	K /W

**BRAKE-CHOPPER SECTOR**

**ABSOLUTE MAXIMUM RATINGS**

*T<sub>C</sub>=25°C unless otherwise specified*

Symbol	Parameter	Test Conditions	Values	Unit
<b>IGBT</b>				
V <sub>CES</sub>	Collector - Emitter Voltage	T <sub>Vj</sub> =25°C	1200	V
V <sub>GES</sub>	Gate - Emitter Voltage		±20	V
I <sub>C</sub>	DC Collector Current	T <sub>C</sub> =25°C	25	A
		T <sub>C</sub> =80°C	15	A
I <sub>CM</sub>	Repetitive Peak Collector Current	t <sub>p</sub> =1ms	30	A
P <sub>tot</sub>	Power Dissipation Per IGBT		105	W
<b>Diode</b>				
V <sub>RRM</sub>	Repetitive Reverse Voltage	T <sub>Vj</sub> =25°C	1200	V
I <sub>F(AV)</sub>	Average Forward Current	T <sub>C</sub> =25°C	25	A
		T <sub>C</sub> =80°C	15	A
I <sub>FRM</sub>	Repetitive Peak Forward Current	t <sub>p</sub> =1ms	30	A
I <sup>2</sup> t		T <sub>Vj</sub> =125°C, t=10ms, V <sub>R</sub> =0V	60	A <sup>2</sup> s

**BRAKE-CHOPPER SECTOR**

**ELECTRICAL AND THERMAL CHARACTERISTICS** *T<sub>C</sub>=25°C unless otherwise specified*

Symbol	Parameter	Test Conditions	Min.	Typ.	Max.	Unit
<b>IGBT</b>						
V <sub>GE(th)</sub>	Gate - Emitter Threshold Voltage	V <sub>CE</sub> =V <sub>GE</sub> , I <sub>C</sub> =0.5mA	5.0	5.8	6.5	V
V <sub>CE(sat)</sub>	Collector - Emitter Saturation Voltage	I <sub>C</sub> =15A, V <sub>GE</sub> =15V, T <sub>VJ</sub> =25°C		1.7		V
		I <sub>C</sub> =15A, V <sub>GE</sub> =15V, T <sub>VJ</sub> =125°C		1.9		V
I <sub>CEs</sub>	Collector Leakage Current	V <sub>CE</sub> =1200V, V <sub>GE</sub> =0V, T <sub>VJ</sub> =25°C			50	μA
		V <sub>CE</sub> =1200V, V <sub>GE</sub> =0V, T <sub>VJ</sub> =125°C			1	mA
I <sub>GES</sub>	Gate Leakage Current	V <sub>CE</sub> =0V, V <sub>GE</sub> ± 15V, T <sub>VJ</sub> =125°C	-400		400	nA
R <sub>Gint</sub>	Integrated Gate Resistor			0		Ω
Q <sub>ge</sub>	Gate Charge	V <sub>CE</sub> =600V, I <sub>C</sub> =15A, V <sub>GE</sub> = ± 15V		0.15		μC
C <sub>ies</sub>	Input Capacitance	V <sub>CE</sub> =25V, V <sub>GE</sub> =0V, f =1MHz		1.1		nF
C <sub>res</sub>	Reverse Transfer Capacitance			0.05		nF
t <sub>d(on)</sub>	Turn - on Delay Time	V <sub>CC</sub> =600V, I <sub>C</sub> =15A, T <sub>VJ</sub> =25°C		90		ns
		R <sub>G</sub> =62 Ω, T <sub>VJ</sub> =125°C		90		ns
t <sub>r</sub>	Rise Time	V <sub>GE</sub> = ± 15V, T <sub>VJ</sub> =25°C		25		ns
		Inductive Load T <sub>VJ</sub> =125°C		30		ns
t <sub>d(off)</sub>	Turn - off Delay Time	V <sub>CC</sub> =600V, I <sub>C</sub> =15A, T <sub>VJ</sub> =25°C		420		ns
		R <sub>G</sub> =62 Ω, T <sub>VJ</sub> =125°C		520		ns
t <sub>f</sub>	Fall Time	V <sub>GE</sub> = ± 15V, T <sub>VJ</sub> =25°C		90		ns
		Inductive Load T <sub>VJ</sub> =125°C		120		ns
E <sub>on</sub>	Turn - on Energy	V <sub>CC</sub> =600V, I <sub>C</sub> =15A, T <sub>VJ</sub> =25°C		1.4		mJ
		R <sub>G</sub> =62 Ω, T <sub>VJ</sub> =125°C		2.0		mJ
E <sub>off</sub>	Turn - off Energy	V <sub>GE</sub> = ± 15V, T <sub>VJ</sub> =25°C		1.0		mJ
		Inductive Load T <sub>VJ</sub> =125°C		1.2		mJ
I <sub>sc</sub>	Short Circuit Current	t <sub>psc</sub> ≤10μS, V <sub>GE</sub> =15V T <sub>VJ</sub> =125°C, V <sub>CC</sub> =900V		55		A
R <sub>thJC</sub>	Junction-to-Case Thermal Resistance ( Per IGBT )				1.2	K /W
<b>Diode</b>						
V <sub>F</sub>	Forward Voltage	I <sub>F</sub> =15A, V <sub>GE</sub> =0V, T <sub>VJ</sub> =25°C		1.65		V
		I <sub>F</sub> =15A, V <sub>GE</sub> =0V, T <sub>VJ</sub> =125°C		1.75		V
t <sub>rr</sub>	Reverse Recovery Time	I <sub>F</sub> =15A, V <sub>R</sub> =600V		150		ns
I <sub>RRM</sub>	Max. Reverse Recovery Current	di <sub>F</sub> /dt=-400A/μs		15		A
E <sub>rec</sub>	Reverse Recovery Energy	T <sub>VJ</sub> =125°C		0.6		mJ
R <sub>thJCD</sub>	Junction-to-Case Thermal Resistance ( Per Diode )				2.1	K /W

**NTC SECTOR**

**CHARACTERISTIC VALUES**

*T<sub>C</sub>=25°C unless otherwise specified*

Symbol	Parameter	Test Conditions	Min.	Typ.	Max.	Unit
R <sub>25</sub>	Resistance	T <sub>C</sub> =25°C		5		KΩ
B <sub>25/50</sub>				3375		K

**MODULE CHARACTERISTICS**

*T<sub>C</sub>=25°C unless otherwise specified*

Symbol	Parameter	Test Conditions	Min.	Typ.	Max.	Unit
T <sub>Vj max</sub>	Max. Junction Temperature				150	°C
T <sub>Vj op</sub>	Operating Temperature		-40		125	°C
T <sub>stg</sub>	Storage Temperature		-40		125	°C
V <sub>isol</sub>	Insulation Test Voltage	AC, t=1min		3000		V
CTI	Comparative Tracking Index		250			
M <sub>d</sub>	Mounting Torque	Recommended (M5)	2.5		5	N· m
Weight				180		g

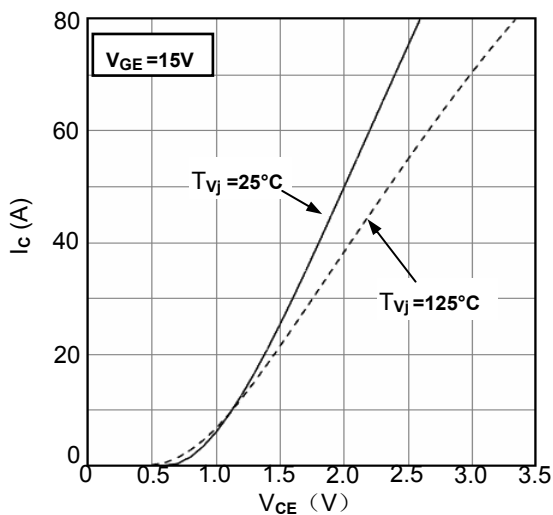

Figure1. Typical Output Characteristics IGBT-inverter

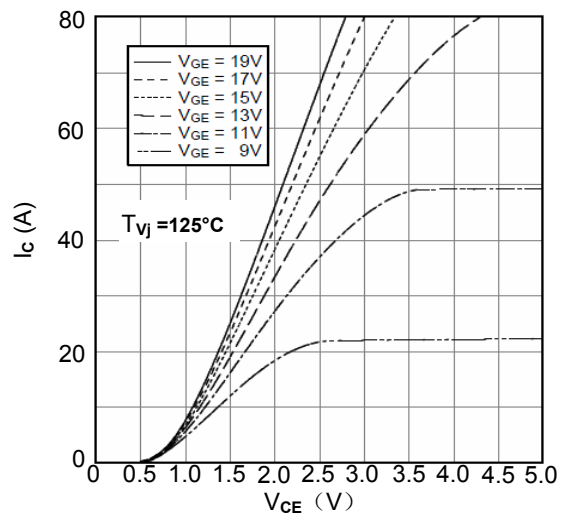

Figure2. Typical Output Characteristics IGBT-inverter

# MIMMG40H120XB6TN

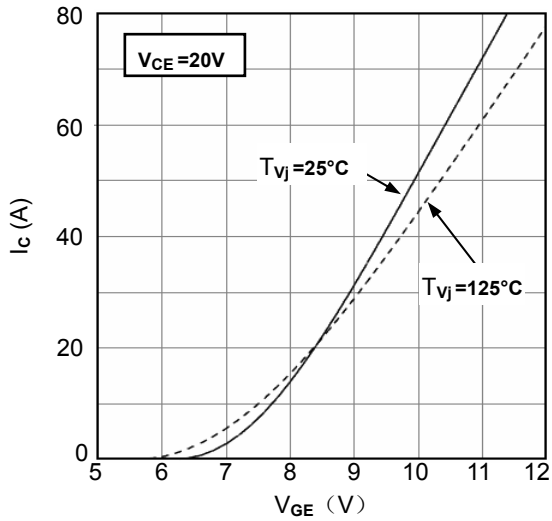

Figure3. Typical Transfer characteristics IGBT-inverter

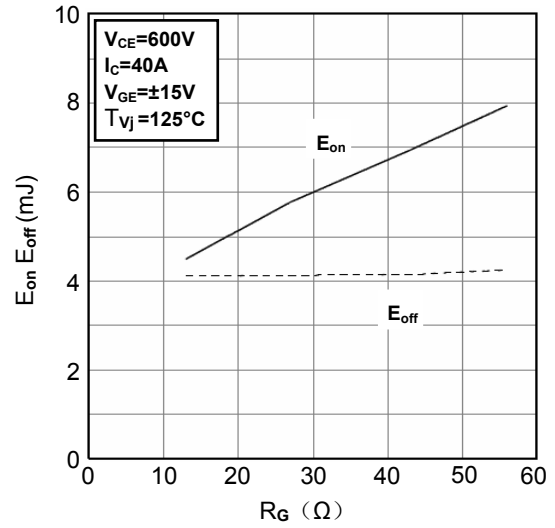

Figure4. Switching Energy vs. Gate Resistor IGBT-inverter

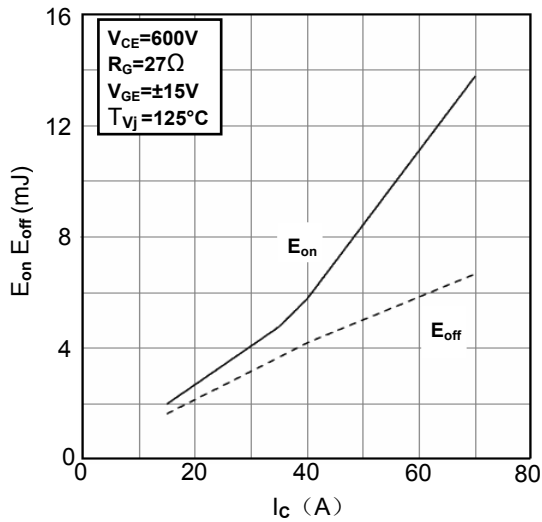

Figure5. Switching Energy vs. Collector Current IGBT-inverter

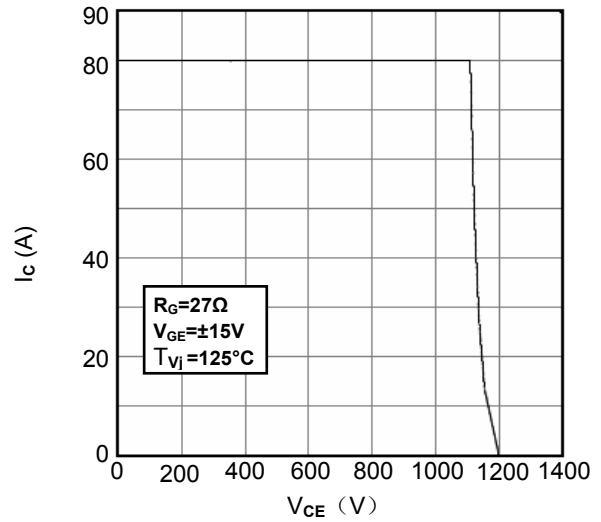

Figure6. Reverse Biased Safe Operating Area IGBT-inverter

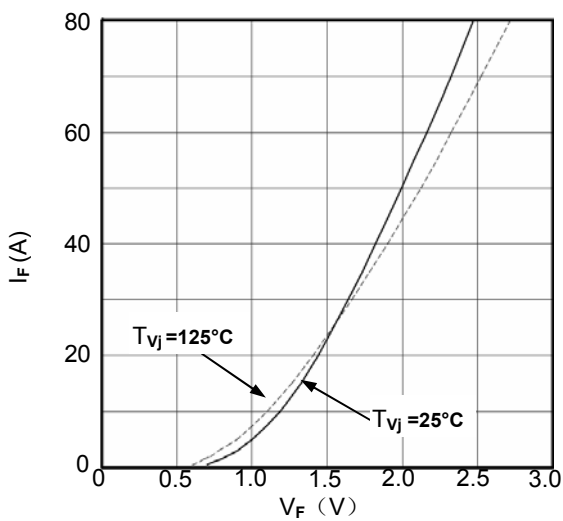

Figure7. Diode Forward Characteristics Diode -inverter

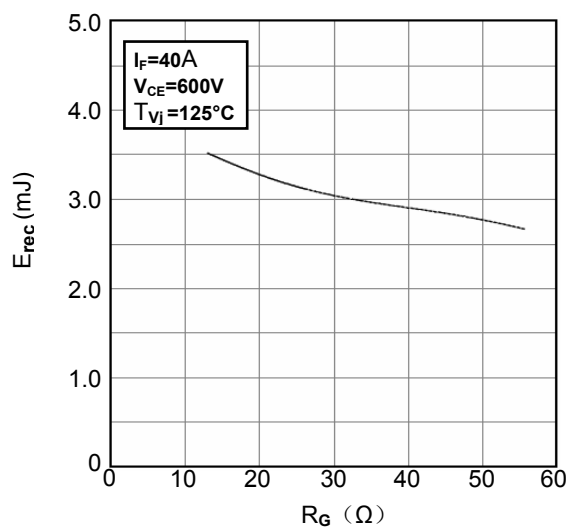

Figure8. Switching Energy vs. Gate Resistor Diode -inverter

# MIMMG40H120XB6TN

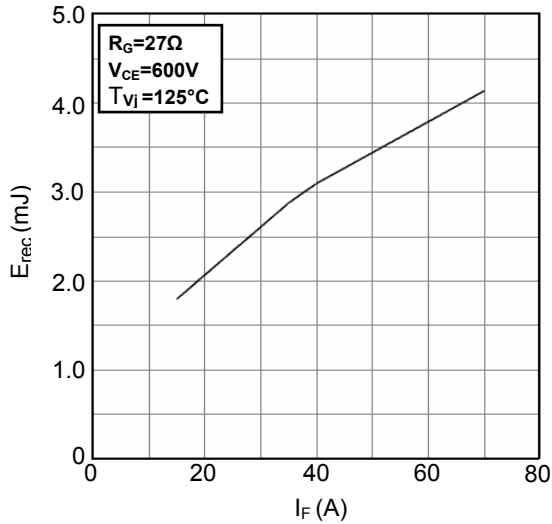

Figure9. Switching Energy vs. Forward Current Diode-inverter

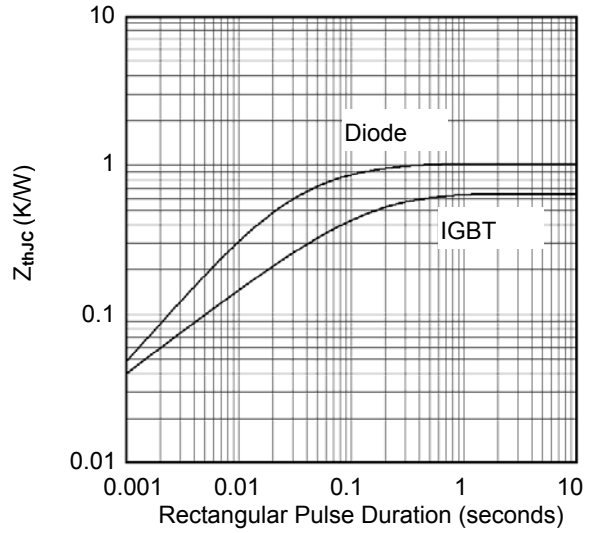

Figure10. Transient Thermal Impedance of Diode and IGBT-inverter

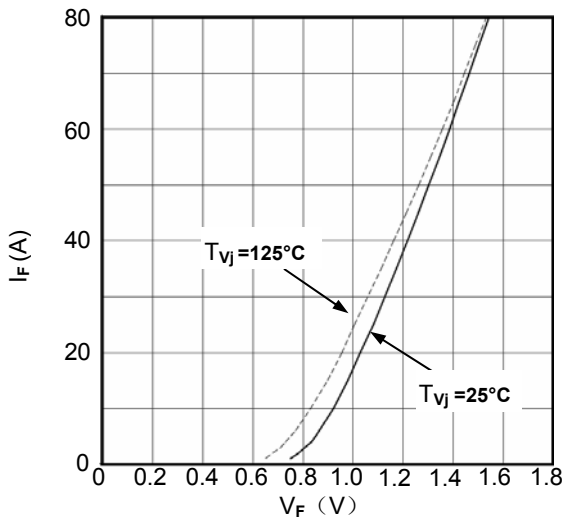

Figure11. Diode Forward Characteristics Diode- rectifier

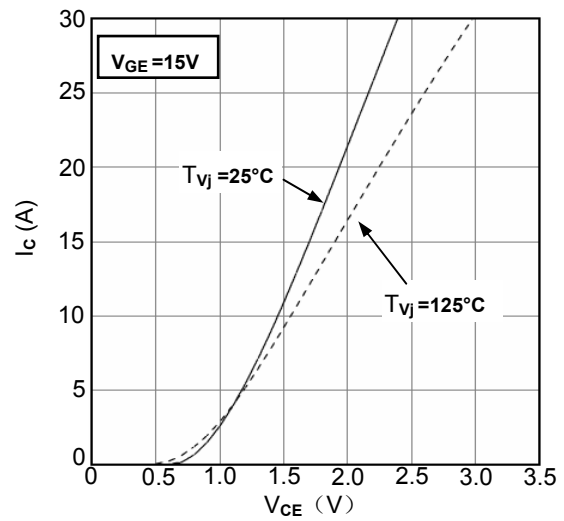

Figure12. Typical Output Characteristics IGBT- brake chopper

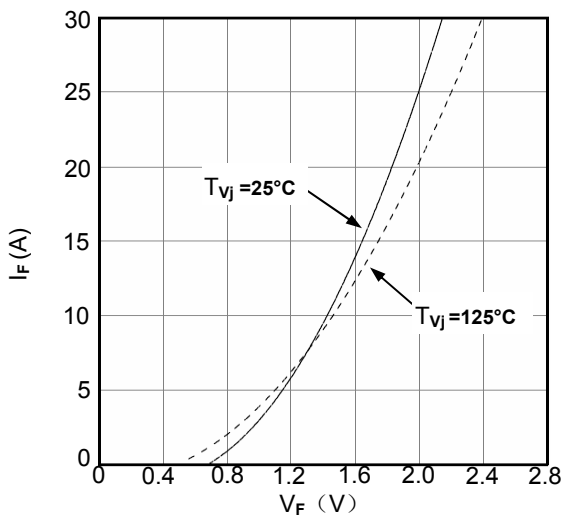

Figure13. Diode Forward Characteristics Diode - brake chopper

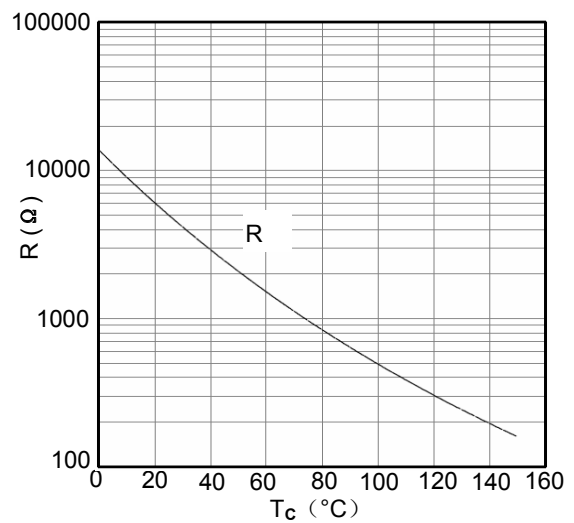

Figure14. NTC Characteristics

# MIMMG40H120XB6TN

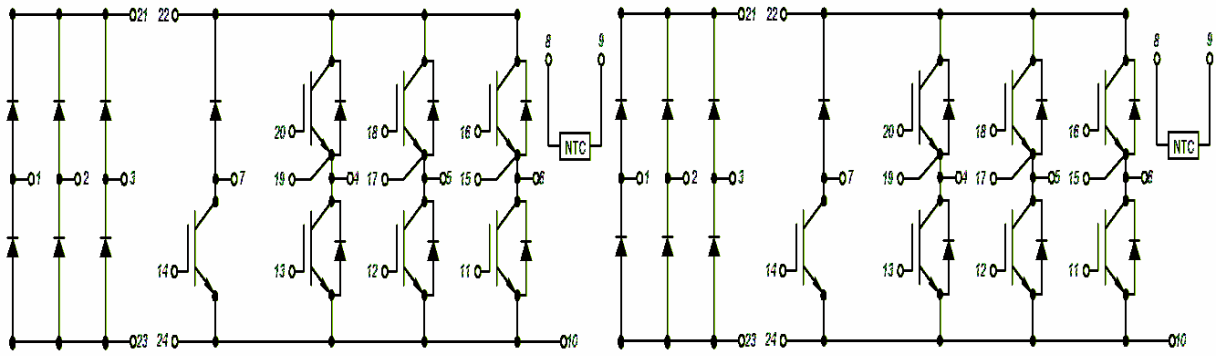
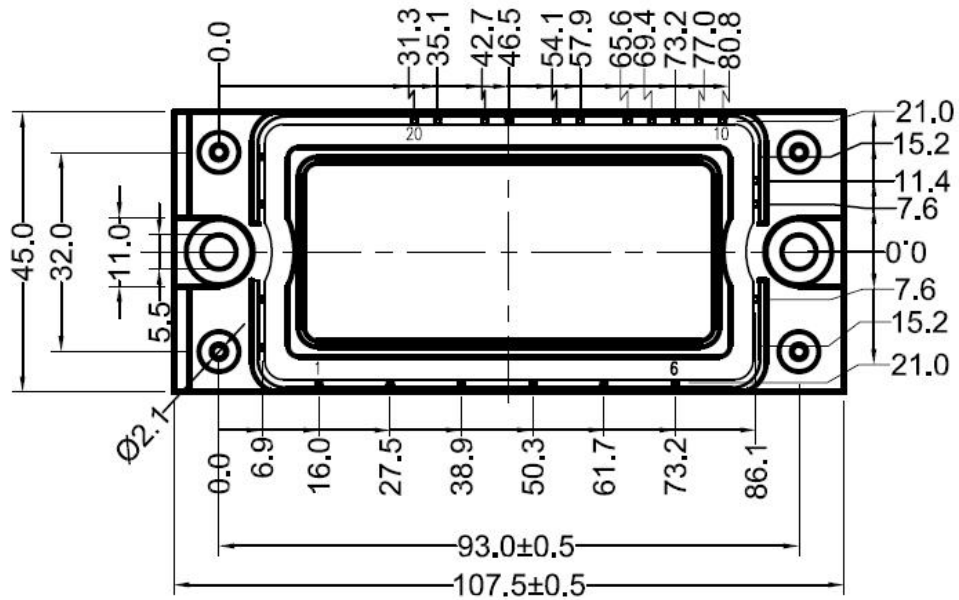
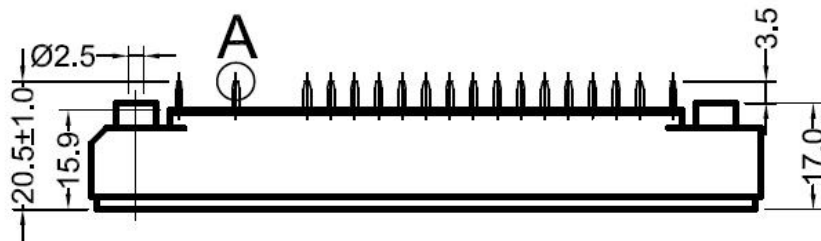

Figure15. Circuit Diagram



Dimensions (mm)

Figure16. Package Outline