



Film capacitors - AC capacitors Motor run capacitors

Series/Type: **B32328**

The following products presented in this data sheet are being withdrawn.

Ordering Code	Substitute Product	Date of Withdrawal	Deadline Last Orders	Last Shipments
B32328A4256J037		2013-02-08	2013-05-08	2013-08-08

For further information please contact your nearest EPCOS sales office, which will also support you in selecting a suitable substitute. The addresses of our worldwide sales network are presented at www.epcos.com/sales.

Construction

- Dielectric: polypropylene film
- Plastic can and top UL 94 V2 material
- Dry type

Features

- Self-healing properties
- Low dissipation factor
- P0 as per IEC 60252-1 2001-02
- High insulation resistance
- Case IP 53 protected
- IEC/EN 60335-1 compatible on request

Typical applications

- For general sine wave applications, mainly as motor run capacitor

Terminals

- Twin core cable type PP 2 × 0.50 mm², 600 V, 95 °C
- Connectors on request

Mounting parts (optional)

- Threaded stud at bottom of can (max. torque = 5 Nm)
- Fast fixation for mounting into a hole of Ø 8 mm



Technical data and specifications	
Reference standards	IEC 60252-1 2001-02 / EN 60252 2001
Safety class to IEC 60252-1 2001-02	P0
Life expectancy to IEC 60252 2001	250 V/85 °C: 10,000 h (class B) 400 V/85 °C: 10,000 h (class B) 480 V/85 °C: 3,000 h (class C)
Rated capacitance C _R	See dimensions table
Tolerance	±5%
Rated voltage V _R	250 V, 400 V, 480 V
Rated frequency f _R	50/60 Hz
Maximum ratings	
Maximum permissible voltage V _{max}	1.1 × V _R (V _R = Rated voltage)
Maximum permissible current I _{max}	1.3 × I _R (I _R = Rated current)

Film capacitors – AC capacitors
Motor Run Capacitors
B32328 – MotorCap™

Test data	
AC test voltage terminal to terminal V_{TT}	$2 \cdot V_R$, 2 s (routine test) $2 \cdot V_R$, 60 s (type test)
Insulation resistance R_{ins} or time constant τ at 20 °C, rel. humidity $\leq 65\%$ (minimum as-delivered values)	3,000 s
Dissipation factor $\tan \delta$ at 20 °C	$\leq 1,0 \cdot 10^{-3}$ (120 Hz)
Maximum rate of voltage rise dV/dt_{max}	10 V/ μ s
Climatic data	
Climatic category	25/085/21 to IEC 60068-1
Lower category T_{min}	-25 °C
Upper category T_{max}	+85 °C
Damp heat test t_{test}	21 days
Mechanical and thermal properties	
Ball pressure test to IEC 60309-1 sec. 27.3	20 N at 125 °C
Plastic can and top disk material	Compliant to EN 60252
<ul style="list-style-type: none"> ■ UL 94 V2 compatible ■ Glow wire test to IEC 60695-2-1/0 and -2-1/1 Test temp 550 °C for $I_R \leq 0.5$ A Test temp 750 °C for $I_R > 0.5$ A 	Self extinguish within 30 seconds of withdrawing the glow wire and without igniting wrapping tissue.
Tracking test to IEC 60112 solution A	> 250 V
Protection class to IEC 60529 2001	IP 53
Compatibility to RoHS	
Compliance to directive 2002/95/EC	
Approvals	
VDE	
400 V/85 °C: 10,000 h (class B) for 1,5 μ F ... 50 μ F	Approved
480 V/85 °C: 3,000 h (class C) for 3 μ F ... 35 μ F	Approved

Dimensional drawing

Mounting options

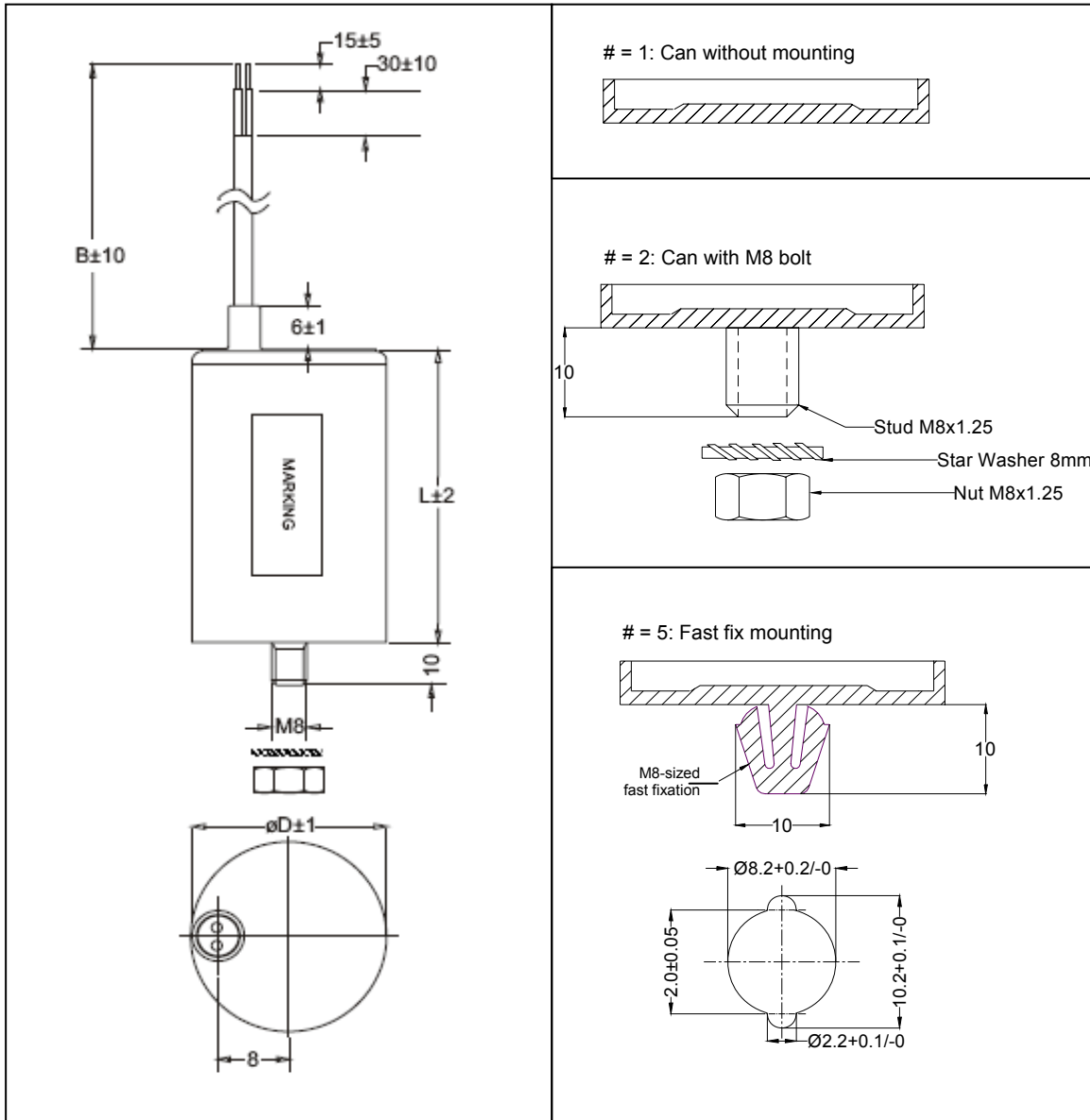

Ordering codes and packing units

V _R V AC	C _R μF	Max. dimensions d × l mm	Ordering code	Packing units pcs.
250	1,5	25 × 58	B32328A1155J0#*	112
	2	25 × 58	B32328A1205J0#*	112
	3	25 × 58	B32328A1305J0#*	112
	4	25 × 58	B32328A1405J0#*	112
	5	25 × 58	B32328A1505J0#*	112
	6	25 × 58	B32328A1605J0#*	112
	7	25 × 58	B32328A1705J0#*	112
	7,5	25 × 58	B32328A1755J0#*	112
	8	25 × 58	B32328A1805J0#*	112
	9	30 × 62	B32328A1905J0#*	112
	10	30 × 62	B32328A1106J0#*	112
	12	30 × 62	B32328A1126J0#*	112
	14	30 × 62	B32328A1146J0#*	112
	15	30 × 62	B32328A1156J0#*	112
	16	30 × 62	B32328A1166J0#*	112
	18	30 × 62	B32328A1186J0#*	112
	20	35 × 62	B32328A1206J0#*	84
	22	35 × 62	B32328A1226J0#*	84
	25	35 × 71	B32328A1256J0#*	84
	30	35 × 71	B32328A1306J0#*	84
	35	40 × 71	B32328A1356J0#*	60
	40	40 × 71	B32328A1406J0#*	60
45	40 × 71	B32328A1456J0#*	60	
50	40 × 95	B32328A1506J0#*	60	
55	40 × 95	B32328A1556J0#*	60	
60	40 × 95	B32328A1606J0#*	60	

Film capacitors – AC capacitors
Motor Run Capacitors
B32328 – MotorCap™

V _R V AC	C _R μF	Max. dimensions d × l mm	Ordering code	Packing units pcs.
400	1,5	25 × 58	B32328A4155J0#*	112
	2	25 × 58	B32328A4205J0#*	112
	3	25 × 58	B32328A4305J0#*	112
	4	25 × 58	B32328A4405J0#*	112
	5	30 × 62	B32328A4505J0#*	112
	6	30 × 62	B32328A4605J0#*	112
	7	35 × 62	B32328A4705J0#*	84
	7,5	35 × 62	B32328A4755J0#*	84
	8	35 × 62	B32328A4805J0#*	84
	9	35 × 62	B32328A4905J0#*	84
	10	35 × 62	B32328A4106J0#*	84
	12	35 × 71	B32328A4126J0#*	84
	14	35 × 71	B32328A4146J0#*	84
	15	40 × 71	B32328A4156J0#*	60
	16	40 × 71	B32328A4166J0#*	60
	18	40 × 71	B32328A4186J0#*	60
	20	40 × 71	B32328A4206J0#*	60
	22	40 × 71	B32328A4226J0#*	60
	25	40 × 95	B32328A4256J0#*	60
	30	40 × 95	B32328A4306J0#*	60
	35	45 × 95	B32328A4356J0#*	45
	40	45 × 95	B32328A4406J0#*	45
45	50 × 95	B32328A4456J0#*	32	
50	50 × 95	B32328A4506J0#*	32	
55	50 × 95	B32328A4556J0#*	32	
60	50 × 95	B32328A4606J0#*	32	

Film capacitors – AC capacitors
Motor Run Capacitors
B32328 – MotorCap™

V _R V AC	C _R μF	Max. dimensions d × l mm	Ordering code	Packing units pcs.
480	3	30 × 62	B32328A8305J0#*	112
	4	30 × 62	B32328A8405J0#*	112
	6	35 × 62	B32328A8605J0#*	84
	7,5	35 × 62	B32328A8755J0#*	84
	8	35 × 71	B32328A8805J0#*	84
	10	40 × 71	B32328A8106J0#*	60
	12	40 × 71	B32328A8126J0#*	60
	15	45 × 71	B32328A8156J0#*	45
	16	45 × 71	B32328A8166J0#*	45
	20	45 × 71	B32328A8206J0#*	45
	22	45 × 71	B32328A8226J0#*	45
	25	45 × 95	B32328A8256J0#*	45
	30	45 × 95	B32328A8306J0#*	45
	35	45 × 95	B32328A8356J0#*	32
	40	45 × 120	B32328A8406J0#*	45
	45	50 × 120	B32328A8456J0#*	32
50	50 × 120	B32328A8506J0#*	32	

Composition of ordering code:

: Construction

- 1 plastic can
- 3 plastic can with M8 bolt
- 5 plastic can with fast fixation device, available for diameters 30 mm, 32 mm and 35 mm, others on request

: Wire length (dimension 'b' in drawing)

- 7 200 mm
- 9 300 mm
- others on request

⚠ Please read "Applications warning, installation and maintenance instructions" and the "General Safety Data Sheet for Power Capacitors" issued by ZVEI, which are available on the internet at www.epcos.com/ac_capacitors, to ensure optimum performance and to prevent products from failing, and in worst case, bursting and fire. Information given in the data sheet reflects typical specifications. You are kindly requested to approve our product specifications or request our approval for your specification before ordering.

Important notes

The following applies to all products named in this publication:

1. Some parts of this publication contain **statements about the suitability of our products for certain areas of application**. These statements are based on our knowledge of typical requirements that are often placed on our products in the areas of application concerned. We nevertheless expressly point out **that such statements cannot be regarded as binding statements about the suitability of our products for a particular customer application**. As a rule, EPCOS is either unfamiliar with individual customer applications or less familiar with them than the customers themselves. For these reasons, it is always ultimately incumbent on the customer to check and decide whether an EPCOS product with the properties described in the product specification is suitable for use in a particular customer application.
2. We also point out that **in individual cases, a malfunction of passive electronic components or failure before the end of their usual service life cannot be completely ruled out in the current state of the art, even if they are operated as specified**. In customer applications requiring a very high level of operational safety and especially in customer applications in which the malfunction or failure of a passive electronic component could endanger human life or health (e.g. in accident prevention or lifesaving systems), it must therefore be ensured by means of suitable design of the customer application or other action taken by the customer (e.g. installation of protective circuitry or redundancy) that no injury or damage is sustained by third parties in the event of malfunction or failure of a passive electronic component.
3. **The warnings, cautions and product specific notes must be observed.**
4. In order to satisfy certain technical requirements, **some of the products described in this publication may contain substances subject to restrictions in certain jurisdictions (e.g. because they are classed as “hazardous”)**. Useful information on this will be found in our Material Data Sheets on the Internet (www.epcos.com/material). Should you have any more detailed questions, please contact our sales offices.
5. We constantly strive to improve our products. Consequently, **the products described in this publication may change from time to time**. The same is true of the corresponding product specifications. Please check therefore to what extent product descriptions and specifications contained in this publication are still applicable before or when you place an order.

We also **reserve the right to discontinue production and delivery of products**. Consequently, we cannot guarantee that all products named in this publication will always be available.
6. Unless otherwise agreed in individual contracts, **all orders are subject to the current version of the “General Terms of Delivery for Products and Services in the Electrical Industry” published by the German Electrical and Electronics Industry Association (ZVEI)**.
7. The trade names EPCOS, BAOKE, Alu-X, CeraDiode, CSSP, MiniBlue, MKK, MLSC, MotorCap, PCC, PhaseCap, PhaseMod, SIFI, SIKOREL, SilverCap, SIMDAD, SIMID, SineFormer, SIOV, SIP5D, SIP5K, ThermoFuse, WindCap are **trademarks registered or pending** in Europe and in other countries. Further information will be found on the Internet at www.epcos.com/trademarks.