

SOT-723 Plastic-Encapsulate MOSFETS

CJ3139K P-Channel MOSFET

FEATURES

- Lead Free Product is Acquired
- Surface Mount Package
- P-Channel Switch with Low $R_{DS(on)}$
- Operated at Low Logic Level Gate Drive

APPLICATION

- Load/Power Switching
- Interfacing, Logic Switching
- Battery Management for Ultra Small Portable Electronics

MARKING: KD

Maximum ratings ($T_a=25^{\circ}\text{C}$ unless otherwise noted)

Parameter	Symbol	Value	Unit
Drain-Source Voltage	V_{DS}	-20	V
Gate-Source Voltage	V_{GS}	± 12	V
Continuous Drain Current (note 1)	I_D	-0.66	A
Pulsed Drain Current ($t_p=10 \mu s$)	I_{DM}	-1.2	A
Power Dissipation (note 1)	P_D	150	mW
Thermal Resistance from Junction to Ambient (note 1)	$R_{\theta JA}$	833	$^{\circ}\text{C}/\text{W}$
Junction Temperature	T_J	150	$^{\circ}\text{C}$
Storage Temperature	T_{STG}	-55~+150	$^{\circ}\text{C}$
Lead Temperature for Soldering Purposes(1/8" from case for 10 s)	T_L	260	$^{\circ}\text{C}$

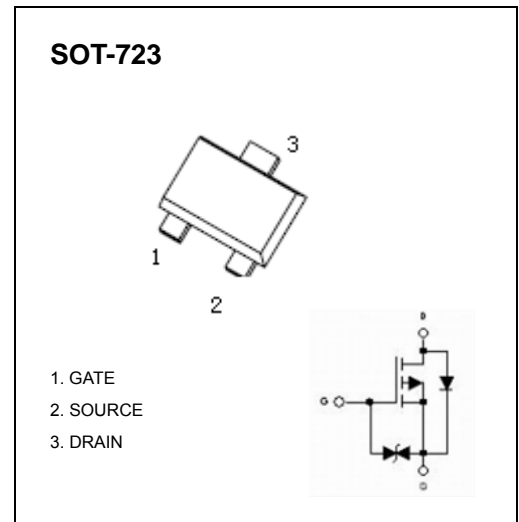

Electrical characteristics (T_a=25°C unless otherwise noted)

Parameter	Symbol	Test Condition	Min	Typ	Max	Unit
STATIC CHARACTERISTICS						
Drain-source breakdown voltage	V _{(BR)DSS}	V _{GS} = 0V, I _D = -250μA	-20			V
Zero gate voltage drain current	I _{DSS}	V _{DS} = -20V, V _{GS} = 0V			-1	μA
Gate-body leakage current	I _{GSS}	V _{GS} = ±12V, V _{DS} = 0V			20	μA
Gate threshold voltage (note 2)	V _{GS(th)}	V _{DS} = V _{GS} , I _D = -250μA	-0.35		-1.1	V
Drain-source on-resistance (note 2)	R _{DS(on)}	V _{GS} = -4.5V, I _D = -1A			520	mΩ
		V _{GS} = -2.5V, I _D = -0.8A			700	mΩ
		V _{GS} = -1.8V, I _D = -0.5A			950	mΩ
Forward transconductance (note 2)	g _{FS}	V _{DS} = -10V, I _D = -0.54A		1.2		S
Diode forward voltage	V _{SD}	I _S = -0.5A, V _{GS} = 0V			-1.2	V
DYNAMIC CHARACTERISTICS (note 4)						
Input capacitance	C _{iss}	V _{DS} = -16V, V _{GS} = 0V, f = 1MHz		113	170	pF
Output capacitance	C _{oss}			15	25	pF
Reverse transfer capacitance	C _{rss}			9	15	pF
SWITCHING CHARACTERISTICS (note 4)						
Turn-on delay time (note 3)	t _{d(on)}	V _{GS} = -4.5V, V _{DS} = -10V, I _D = -200mA, R _{GEN} = 10Ω		9		ns
Turn-on rise time (note 3)	t _r			5.8		ns
Turn-off delay time (note 3)	t _{d(off)}			32.7		ns
Turn-off fall time (note 3)	t _f			20.3		ns

Notes :

1. Surface mounted on FR4 board using the minimum recommended pad size.
2. Pulse Test : Pulse Width=300μs, Duty Cycle=2%.
3. Switching characteristics are independent of operating junction temperatures.
4. Guaranteed by design, not subject to producing.

CJ3139K

Output Characteristics

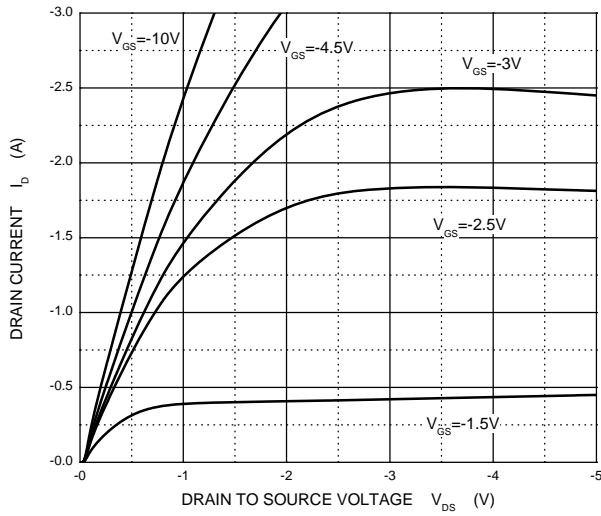

Transfer Characteristics

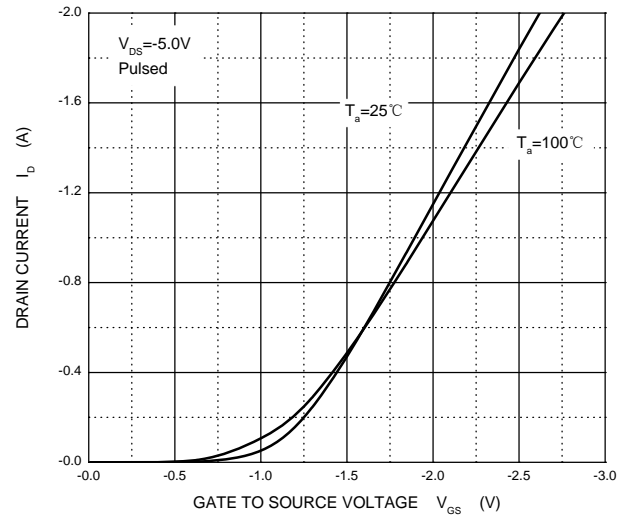

$R_{DS(ON)}$ — I_D

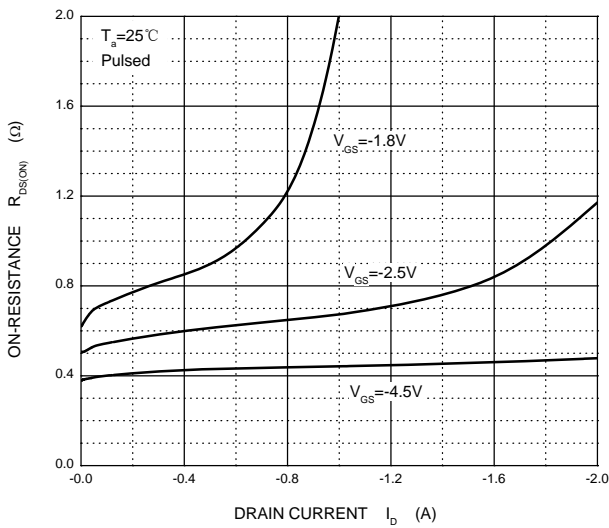

$R_{DS(ON)}$ — V_{GS}

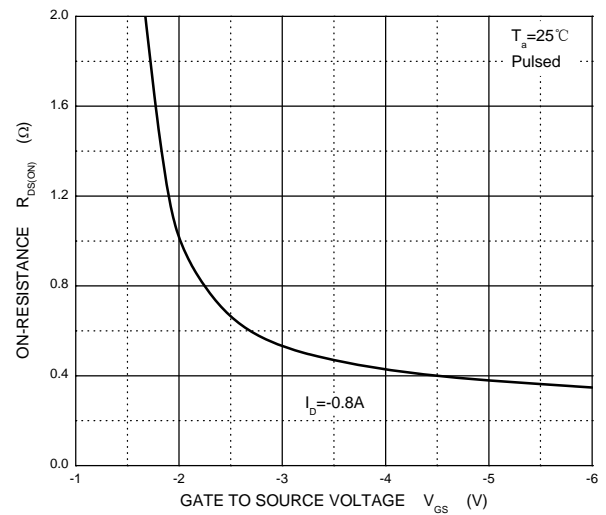

I_S — V_{SD}

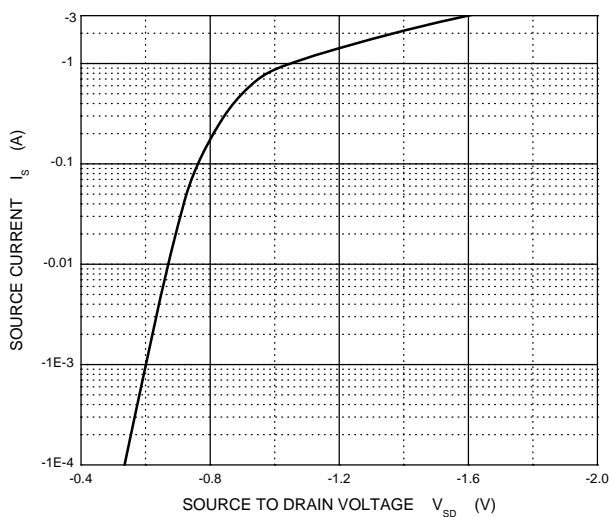

Threshold Voltage

