

## ARM<sup>®</sup>-based 32-bit MCU, up to 32 KB Flash, crystal-less USB FS 2.0, CAN, 8 timers, ADC & comm. interfaces, 2.0 - 3.6 V

Datasheet - production data

### Features

- Core: ARM<sup>®</sup> 32-bit Cortex<sup>®</sup>-M0 CPU, frequency up to 48 MHz
- Memories
  - 16 to 32 Kbytes of Flash memory
  - 6 Kbytes of SRAM with HW parity
- CRC calculation unit
- Reset and power management
  - Digital and I/Os supply:  $V_{DD} = 2\text{ V to }3.6\text{ V}$
  - Analog supply:  $V_{DDA} = V_{DD}$  to 3.6 V
  - Selected I/Os:  $V_{DDIO2} = 1.65\text{ V to }3.6\text{ V}$
  - Power-on/Power down reset (POR/PDR)
  - Programmable voltage detector (PVD)
  - Low power modes: Sleep, Stop, Standby
  - $V_{BAT}$  supply for RTC and backup registers
- Clock management
  - 4 to 32 MHz crystal oscillator
  - 32 kHz oscillator for RTC with calibration
  - Internal 8 MHz RC with x6 PLL option
  - Internal 40 kHz RC oscillator
  - Internal 48 MHz oscillator with automatic trimming based on ext. synchronization
- Up to 37 fast I/Os
  - All mappable on external interrupt vectors
  - Up to 37 I/Os with 5 V tolerant capability and 8 with independent supply  $V_{DDIO2}$
- 5-channel DMA controller
- One 12-bit, 1.0  $\mu\text{s}$  ADC (up to 10 channels)
  - Conversion range: 0 to 3.6 V
  - Separate analog supply: 2.4 V to 3.6 V
- Up to 14 capacitive sensing channels for touchkey, linear and rotary touch sensors
- Calendar RTC with alarm and periodic wakeup from Stop/Standby

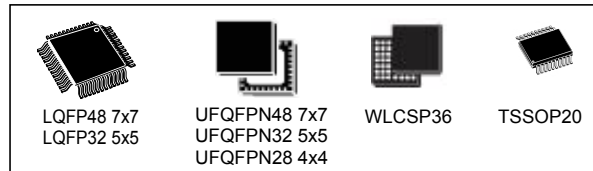

- Nine timers
  - One 16-bit advanced-control timer for six channel PWM output
  - One 32-bit and four 16-bit timers, with up to four IC/OC, OCN, usable for IR control decoding
  - Independent and system watchdog timers
  - SysTick timer
- Communication interfaces
  - One I<sup>2</sup>C interface supporting Fast Mode Plus (1 Mbit/s) with 20 mA current sink, SMBus/PMBus and wakeup
  - Two USARTs supporting master synchronous SPI and modem control; one with ISO7816 interface, LIN, IrDA, auto baud rate detection and wakeup feature
  - Two SPIs (18 Mbit/s) with four to 16 programmable bit frames, one with I<sup>2</sup>S interface multiplexed
  - CAN interface
  - USB 2.0 full-speed interface, able to run from internal 48 MHz oscillator and with BCD and LPM support
- HDMI CEC, wakeup on header reception
- Serial wire debug (SWD)
- 96-bit unique ID
- All packages ECOPACK<sup>®</sup>2

**Table 1. Device summary**

Reference	Part number
STM32F042xx	STM32F042F4, STM32F042G4, STM32F042K4, STM32F042T4, STM32F042C4 STM32F042F6, STM32F042G6, STM32F042K6, STM32F042T6, STM32F042C6

# Contents

<b>1</b>	<b>Introduction</b>	<b>9</b>
<b>2</b>	<b>Description</b>	<b>10</b>
<b>3</b>	<b>Functional overview</b>	<b>13</b>
3.1	ARM® Cortex®-M0 core with embedded Flash and SRAM	13
3.2	Memories	13
3.3	Boot modes	13
3.4	Cyclic redundancy check calculation unit (CRC)	14
3.5	Power management	14
3.5.1	Power supply schemes	14
3.5.2	Power supply supervisors	14
3.5.3	Voltage regulator	15
3.5.4	Low-power modes	15
3.6	Clocks and startup	16
3.7	General-purpose inputs/outputs (GPIOs)	17
3.8	Direct memory access controller (DMA)	18
3.9	Interrupts and events	18
3.9.1	Nested vectored interrupt controller (NVIC)	18
3.9.2	Extended interrupt/event controller (EXTI)	18
3.10	Analog to digital converter (ADC)	18
3.10.1	Temperature sensor	19
3.10.2	Internal voltage reference ( $V_{REFINT}$ )	19
3.10.3	$V_{BAT}$ battery voltage monitoring	20
3.11	Touch sensing controller (TSC)	20
3.12	Timers and watchdogs	21
3.12.1	Advanced-control timer (TIM1)	22
3.12.2	General-purpose timers (TIM2..3, TIM14, 16, 17)	22
3.12.3	Independent watchdog (IWDG)	23
3.12.4	System window watchdog (WWDG)	23
3.12.5	SysTick timer	23
3.13	Real-time clock (RTC) and backup registers	23
3.14	Inter-integrated circuit interfaces (I <sup>2</sup> C)	24

3.15	Universal synchronous/asynchronous receiver transmitters (USART) . . .	25
3.16	Serial peripheral interface (SPI)/Inter-integrated sound interfaces (I <sup>2</sup> S) .	26
3.17	High-definition multimedia interface (HDMI) - consumer electronics control (CEC) . . . . .	27
3.18	Controller area network (CAN) . . . . .	27
3.19	Universal serial bus (USB) . . . . .	27
3.20	Clock recovery system (CRS) . . . . .	27
3.21	Serial wire debug port (SW-DP) . . . . .	27
<b>4</b>	<b>Pinouts and pin descriptions . . . . .</b>	<b>28</b>
<b>5</b>	<b>Memory mapping . . . . .</b>	<b>41</b>
<b>6</b>	<b>Electrical characteristics . . . . .</b>	<b>44</b>
6.1	Parameter conditions . . . . .	44
6.1.1	Minimum and maximum values . . . . .	44
6.1.2	Typical values . . . . .	44
6.1.3	Typical curves . . . . .	44
6.1.4	Loading capacitor . . . . .	44
6.1.5	Pin input voltage . . . . .	44
6.1.6	Power supply scheme . . . . .	45
6.1.7	Current consumption measurement . . . . .	46
6.2	Absolute maximum ratings . . . . .	47
6.3	Operating conditions . . . . .	49
6.3.1	General operating conditions . . . . .	49
6.3.2	Operating conditions at power-up / power-down . . . . .	50
6.3.3	Embedded reset and power control block characteristics . . . . .	50
6.3.4	Embedded reference voltage . . . . .	51
6.3.5	Supply current characteristics . . . . .	52
6.3.6	Wakeup time from low-power mode . . . . .	62
6.3.7	External clock source characteristics . . . . .	63
6.3.8	Internal clock source characteristics . . . . .	69
6.3.9	PLL characteristics . . . . .	72
6.3.10	Memory characteristics . . . . .	73
6.3.11	EMC characteristics . . . . .	73
6.3.12	Electrical sensitivity characteristics . . . . .	75

---

6.3.13	I/O current injection characteristics	75
6.3.14	I/O port characteristics	76
6.3.15	NRST pin characteristics	82
6.3.16	12-bit ADC characteristics	83
6.3.17	Temperature sensor characteristics	87
6.3.18	V <sub>BAT</sub> monitoring characteristics	87
6.3.19	Timer characteristics	87
6.3.20	Communication interfaces	88
<b>7</b>	<b>Package characteristics</b>	<b>95</b>
7.1	Package mechanical data	95
7.2	Thermal characteristics	114
7.2.1	Reference document	114
<b>8</b>	<b>Part numbering</b>	<b>115</b>
<b>9</b>	<b>Revision history</b>	<b>116</b>

## List of tables

Table 1.	Device summary . . . . .	1
Table 2.	STM32F042x device features and peripheral counts . . . . .	11
Table 3.	Temperature sensor calibration values . . . . .	19
Table 4.	Internal voltage reference calibration values . . . . .	19
Table 5.	Capacitive sensing GPIOs available on STM32F042x devices . . . . .	20
Table 6.	No. of capacitive sensing channels available on STM32F042x devices. . . . .	21
Table 7.	Timer feature comparison . . . . .	21
Table 8.	Comparison of I2C analog and digital filters . . . . .	24
Table 9.	STM32F042x I <sup>2</sup> C implementation . . . . .	25
Table 10.	STM32F042x USART implementation . . . . .	25
Table 11.	STM32F042x SPI/I2S implementation . . . . .	26
Table 12.	Legend/abbreviations used in the pinout table . . . . .	32
Table 13.	STM32F042x pin definitions . . . . .	33
Table 14.	Alternate functions selected through GPIOA_AFR registers for port A . . . . .	38
Table 15.	Alternate functions selected through GPIOB_AFR registers for port B . . . . .	39
Table 16.	Alternate functions selected through GPIOF_AFR registers for port F . . . . .	40
Table 17.	STM32F042x peripheral register boundary addresses . . . . .	42
Table 18.	Voltage characteristics . . . . .	47
Table 19.	Current characteristics . . . . .	48
Table 20.	Thermal characteristics . . . . .	48
Table 21.	General operating conditions . . . . .	49
Table 22.	Operating conditions at power-up / power-down . . . . .	50
Table 23.	Embedded reset and power control block characteristics . . . . .	50
Table 24.	Programmable voltage detector characteristics . . . . .	50
Table 25.	Embedded internal reference voltage . . . . .	51
Table 26.	Typical and maximum current consumption from V <sub>DD</sub> supply at V <sub>DD</sub> = 3.6 V . . . . .	52
Table 27.	Typical and maximum current consumption from the V <sub>DDA</sub> supply . . . . .	54
Table 28.	Typical and maximum consumption in Stop and Standby modes . . . . .	55
Table 29.	Typical and maximum current consumption from the V <sub>BAT</sub> supply . . . . .	56
Table 30.	Typical current consumption, code executing from Flash, running from HSE 8 MHz crystal . . . . .	57
Table 31.	Switching output I/O current consumption . . . . .	59
Table 32.	Peripheral current consumption . . . . .	60
Table 33.	Low-power mode wakeup timings . . . . .	62
Table 34.	High-speed external user clock characteristics . . . . .	63
Table 35.	Low-speed external user clock characteristics . . . . .	64
Table 36.	HSE oscillator characteristics . . . . .	65
Table 37.	LSE oscillator characteristics (f <sub>LSE</sub> = 32.768 kHz) . . . . .	67
Table 38.	HSI oscillator characteristics . . . . .	69
Table 39.	HSI14 oscillator characteristics . . . . .	70
Table 40.	HSI48 oscillator characteristics . . . . .	71
Table 41.	LSI oscillator characteristics . . . . .	72
Table 42.	PLL characteristics . . . . .	72
Table 43.	Flash memory characteristics . . . . .	73
Table 44.	Flash memory endurance and data retention . . . . .	73
Table 45.	EMS characteristics . . . . .	74
Table 46.	EMI characteristics . . . . .	74
Table 47.	ESD absolute maximum ratings . . . . .	75

Table 48.	Electrical sensitivities	75
Table 49.	I/O current injection susceptibility	76
Table 50.	I/O static characteristics	76
Table 51.	Output voltage characteristics	80
Table 52.	I/O AC characteristics	81
Table 53.	NRST pin characteristics	82
Table 54.	ADC characteristics	83
Table 55.	$R_{AIN}$ max for $f_{ADC} = 14$ MHz	85
Table 56.	ADC accuracy	85
Table 57.	TS characteristics	87
Table 58.	$V_{BAT}$ monitoring characteristics	87
Table 59.	TIMx characteristics	87
Table 60.	IWDG min/max timeout period at 40 kHz (LSI)	88
Table 61.	WWDG min/max timeout value at 48 MHz (PCLK)	88
Table 62.	I2C analog filter characteristics	89
Table 63.	SPI characteristics	90
Table 64.	I <sup>2</sup> S characteristics	92
Table 65.	LQFP48 – 7 mm x 7 mm low-profile quad flat package mechanical data	95
Table 66.	UFQFPN48 – 7 mm x 7 mm, 0.5 mm pitch, package mechanical data	99
Table 67.	WLCSP36, 0.4 mm pitch, package mechanical data	102
Table 68.	LQFP32 – 7 mm x 7 mm 32-pin low-profile quad flat package mechanical data	104
Table 69.	UFQFPN32 – 5 x 5 mm, 32-lead ultra thin fine pitch quad flat no-lead package mechanical data	107
Table 70.	UFQFPN28 – 4 x 4 mm, 28-lead ultra thin fine pitch quad flat no-lead package mechanical data	109
Table 71.	TSSOP20 – 20-pin thin shrink small outline package mechanical data	112
Table 72.	Package thermal characteristics	114
Table 73.	Ordering information scheme	115
Table 74.	Document revision history	116

## List of figures

Figure 1.	Block diagram	12
Figure 2.	Clock tree	17
Figure 3.	LQFP48 48-pin package pinout (top view)	28
Figure 4.	UFQFPN48 48-pin package pinout (top view)	28
Figure 5.	WLCSP36 36-pin package ball-out.	29
Figure 6.	LQFP32 32-pin package pinout (top view)	29
Figure 7.	UFQFPN32 32-pin package pinout (top view)	30
Figure 8.	UQFPN28 28-pin package (top view)	30
Figure 9.	TSSOP20 20-pin package (top view)	31
Figure 10.	STM32F042x memory map	41
Figure 11.	Pin loading conditions	44
Figure 12.	Pin input voltage	44
Figure 13.	Power supply scheme	45
Figure 14.	Current consumption measurement scheme	46
Figure 15.	High-speed external clock source AC timing diagram	63
Figure 16.	Low-speed external clock source AC timing diagram	64
Figure 17.	Typical application with an 8 MHz crystal	66
Figure 18.	Typical application with a 32.768 kHz crystal	68
Figure 19.	HSI oscillator accuracy characterization results	69
Figure 20.	HSI14 oscillator accuracy characterization results	70
Figure 21.	HSI48 oscillator accuracy characterization results	71
Figure 22.	TC and TTA I/O input characteristics	78
Figure 23.	Five volt tolerant (FT and FTf) I/O input characteristics	79
Figure 24.	I/O AC characteristics definition	82
Figure 25.	Recommended NRST pin protection	83
Figure 26.	ADC accuracy characteristics	86
Figure 27.	Typical connection diagram using the ADC	86
Figure 28.	SPI timing diagram - slave mode and CPHA = 0	91
Figure 29.	SPI timing diagram - slave mode and CPHA = 1	91
Figure 30.	SPI timing diagram - master mode	92
Figure 31.	I2S slave timing diagram (Philips protocol)	93
Figure 32.	I2S master timing diagram (Philips protocol)	94
Figure 33.	LQFP48 – 7 mm x 7 mm, 48 pin low-profile quad flat package outline.	95
Figure 34.	LQFP48 recommended footprint.	96
Figure 35.	LQFP48 package top view	97
Figure 36.	UFQFPN48 – 7 mm x 7 mm, 0.5 mm pitch, package outline	98
Figure 37.	UFQFPN48 recommended footprint.	99
Figure 38.	UFQFPN48 package top view	100
Figure 39.	WLCSP36 - 0.4 mm pitch, package outline	101
Figure 40.	WLCSP36 package top view	103
Figure 41.	LQFP32 – 7 mm x 7 mm 32-pin low-profile quad flat package outline	104
Figure 42.	LQFP32 recommended footprint.	105
Figure 43.	LQFP32 package top view	106
Figure 44.	UFQFPN32 - 5 x 5 mm, 32-lead ultra thin fine pitch quad flat no-lead package outline.	107
Figure 45.	UFQFPN32 recommended footprint.	108
Figure 46.	UFQFPN32 package top view	108
Figure 47.	UFQFPN28 - 4 x 4 mm, 28-lead ultra thin fine pitch quad flat no-lead package outline.	109
Figure 48.	UFQFPN28 recommended footprint.	110

Figure 49.	UFQFPN28 package top view . . . . .	111
Figure 50.	TSSOP20 - 20-pin thin shrink small outline . . . . .	112
Figure 51.	TSSOP20 recommended footprint . . . . .	113
Figure 52.	TSSOP20 package top view . . . . .	113



# 1 Introduction

This datasheet provides the ordering information and mechanical device characteristics of the STM32F042x microcontrollers.

This document should be read in conjunction with the STM32F0xxxx reference manual (RM0091). The reference manual is available from the STMicroelectronics website at [www.st.com](http://www.st.com).

For information on the ARM<sup>®</sup> Cortex<sup>®</sup>-M0 core, please refer to the Cortex<sup>®</sup>-M0 Technical Reference Manual, available from ARM website at [www.arm.com](http://www.arm.com).



## 2 Description

The STM32F042x microcontrollers incorporate the high-performance ARM<sup>®</sup> Cortex<sup>®</sup>-M0 32-bit RISC core operating at a 48 MHz frequency, high-speed embedded memories (up to 32 Kbytes of Flash memory and 6 Kbytes of SRAM), and an extensive range of enhanced peripherals and I/Os. All devices offer standard communication interfaces (one I<sup>2</sup>C, two SPIs/one I2S, one HDMI CEC and two USARTs), one USB Full speed device (crystal-less), one CAN, one 12-bit ADC, four general-purpose 16-bit timers, a 32-bit timer and an advanced-control PWM timer.

The STM32F042x microcontrollers operate in the -40 to +85 °C and -40 to +105 °C temperature ranges from a 2.0 to 3.6 V power supply. A comprehensive set of power-saving modes allows the design of low-power applications.

The STM32F042x microcontrollers include devices in seven different packages ranging from 20 pins to 48 pins with a die form also available upon request. Depending on the device chosen, different sets of peripherals are included. The description below provides an overview of the complete range of STM32F042x peripherals proposed.

These features make the STM32F042x microcontrollers suitable for a wide range of applications such as application control and user interfaces, handheld equipment, A/V receivers and digital TV, PC peripherals, gaming and GPS platforms, industrial applications, PLCs, inverters, printers, scanners, alarm systems, video intercoms, and HVACs.

**Table 2. STM32F042x device features and peripheral counts**

Peripheral		STM32F042Fx		STM32F042G		STM32F042K		STM32F042T		STM32F042C	
Flash (Kbytes)		16	32	16	32	16	32	16	32	16	32
SRAM (Kbytes)		6		6		6		6		6	
Timers	Advanced control	1 (16-bit)									
	General purpose	4 (16-bit) 1 (32-bit)									
Comm. interfaces	SPI [I2S] <sup>(1)</sup>	1 [1]								2 [1]	
	I <sup>2</sup> C	1									
	USART	2									
	CAN	1									
	USB	1									
	CEC	1									
12-bit ADC (number of channels)		1 (9 ext. + 3 int.)		1 (10 ext. + 3 int.)							
GPIOs		16		24		26 28		30		38	
Capacitive sensing channels		7		11		13 14		14		14	
Max. CPU frequency		48 MHz									
Operating voltage		2.0 to 3.6 V									
Operating temperature		Ambient operating temperature: -40 °C to 85 °C / -40 °C to 105 °C Junction temperature: -40 °C to 105 °C / -40 °C to 125 °C									
Packages		TSSOP20		UQFPN28		LQFP32 UQFPN32		WLCSP36		LQFP48 UFQFPN48	

1. The SPI1 interface can be used either in SPI mode or in I2S audio mode.

Figure 1. Block diagram

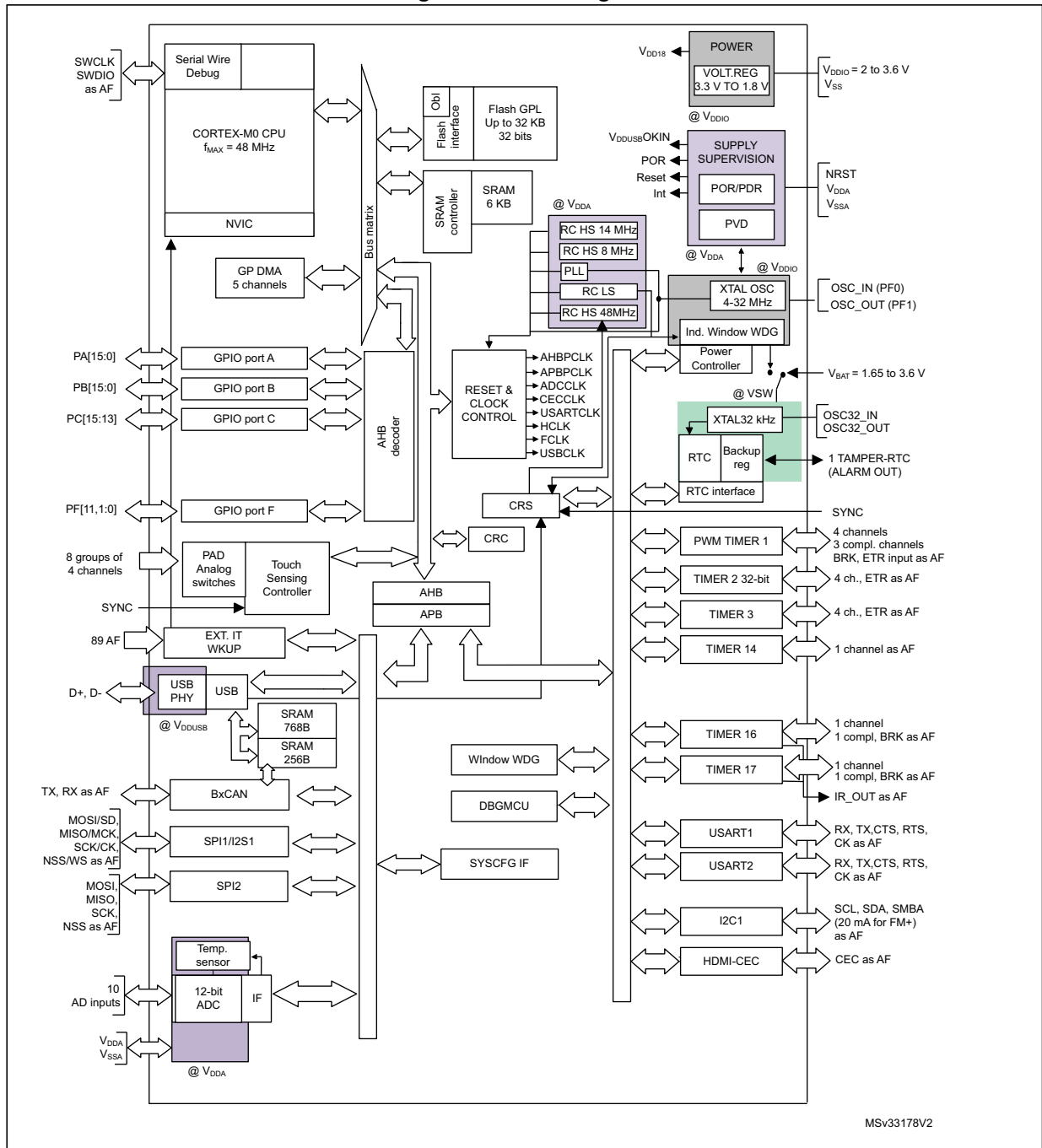

## 3 Functional overview

### 3.1 ARM<sup>®</sup> Cortex<sup>®</sup>-M0 core with embedded Flash and SRAM

The ARM<sup>®</sup> Cortex<sup>®</sup>-M0 processor is the latest generation of ARM processors for embedded systems. It has been developed to provide a low-cost platform that meets the needs of MCU implementation, with a reduced pin count and low-power consumption, while delivering outstanding computational performance and an advanced system response to interrupts.

The ARM<sup>®</sup> Cortex<sup>®</sup>-M0 32-bit RISC processor features exceptional code-efficiency, delivering the high-performance expected from an ARM core in the memory size usually associated with 8- and 16-bit devices.

The STM32F0xx family has an embedded ARM core and is therefore compatible with all ARM tools and software.

*Figure 1* shows the general block diagram of the device family.

### 3.2 Memories

The device has the following features:

- 6 Kbytes of embedded SRAM accessed (read/write) at CPU clock speed with 0 wait states and featuring embedded parity checking with exception generation for fail-critical applications.
- The non-volatile memory is divided into two arrays:
  - 16 to 32 Kbytes of embedded Flash memory for programs and data
  - Option bytes

The option bytes are used to write-protect the memory (with 4 KB granularity) and/or readout-protect the whole memory with the following options:

- Level 0: no readout protection
- Level 1: memory readout protection, the Flash memory cannot be read from or written to if either debug features are connected or boot in RAM is selected
- Level 2: chip readout protection, debug features (Cortex-M0 serial wire) and boot in RAM selection disabled

### 3.3 Boot modes

At startup, the boot pin and boot selector option bits are used to select one of the three boot options:

- Boot from User Flash
- Boot from System Memory
- Boot from embedded SRAM

The boot pin is shared with the standard GPIO and can be disabled through the boot selector option bits. The boot loader is located in System Memory. It is used to reprogram the Flash memory by using USART on pins PA14/PA15 or PA9/PA10, I2C on pins PB6/PB7 or through the USB DFU interface.

## 3.4 Cyclic redundancy check calculation unit (CRC)

The CRC (cyclic redundancy check) calculation unit is used to get a CRC code from a 32-bit data word and a CRC-32 (Ethernet) polynomial.

Among other applications, CRC-based techniques are used to verify data transmission or storage integrity. In the scope of the EN/IEC 60335-1 standard, they offer a means of verifying the Flash memory integrity. The CRC calculation unit helps compute a signature of the software during runtime, to be compared with a reference signature generated at link-time and stored at a given memory location.

## 3.5 Power management

### 3.5.1 Power supply schemes

- $V_{DD} = 2.0$  to  $3.6$  V: external power supply for I/Os and the internal regulator. Provided externally through  $V_{DD}$  pins.
- $V_{DDA} = 2.0$  to  $3.6$  V: external analog power supply for ADC, Reset blocks, RCs and PLL (minimum voltage to be applied to  $V_{DDA}$  is  $2.4$  V when the ADC is used). The  $V_{DDA}$  voltage level must be always greater or equal to the  $V_{DD}$  voltage level and must be provided first.
- $V_{DDIO2} = 1.65$  to  $3.6$  V: external power supply for marked I/Os. Provided externally through the  $V_{DDIO2}$  pin. The  $V_{DDIO2}$  voltage level is completely independent from  $V_{DD}$  or  $V_{DDA}$ , but it must not be provided without a valid supply on  $V_{DD}$ . Refer to the pinout diagrams or tables for concerned I/Os list.
- $V_{BAT} = 1.65$  to  $3.6$  V: power supply for RTC, external clock 32 kHz oscillator and backup registers (through power switch) when  $V_{DD}$  is not present.

### 3.5.2 Power supply supervisors

The device has integrated power-on reset (POR) and power-down reset (PDR) circuits. They are always active, and ensure proper operation above a threshold of 2 V. The device remains in reset mode when the monitored supply voltage is below a specified threshold,  $V_{POR/PDR}$ , without the need for an external reset circuit.

- The POR monitors only the  $V_{DD}$  supply voltage. During the startup phase it is required that  $V_{DDA}$  should arrive first and be greater than or equal to  $V_{DD}$ .
- The PDR monitors both the  $V_{DD}$  and  $V_{DDA}$  supply voltages, however the  $V_{DDA}$  power supply supervisor can be disabled (by programming a dedicated Option bit) to reduce the power consumption if the application design ensures that  $V_{DDA}$  is higher than or equal to  $V_{DD}$ .

The  $V_{DDIO2}$  supply is monitored and compared with the internal reference voltage ( $V_{REFINT}$ ). When the  $V_{DDIO2}$  is below this threshold, all the I/Os supplied from this rail are disabled by hardware. The output of this comparator is connected to EXTI line 31 and it can be used to generate an interrupt.

The device features an embedded programmable voltage detector (PVD) that monitors the  $V_{DD}$  power supply and compares it to the  $V_{PVD}$  threshold. An interrupt can be generated when  $V_{DD}$  drops below the  $V_{PVD}$  threshold and/or when  $V_{DD}$  is higher than the  $V_{PVD}$  threshold. The interrupt service routine can then generate a warning message and/or put the MCU into a safe state. The PVD is enabled by software.

### 3.5.3 Voltage regulator

The regulator has two operating modes and it is always enabled after reset.

- Main (MR) is used in normal operating mode (Run).
- Low power (LPR) can be used in Stop mode where the power demand is reduced.

In Standby mode, it is put in power down mode. In this mode, the regulator output is in high impedance and the kernel circuitry is powered down, inducing zero consumption (but the contents of the registers and SRAM are lost).

### 3.5.4 Low-power modes

The STM32F042x microcontrollers support three low-power modes to achieve the best compromise between low power consumption, short startup time and available wakeup sources:

- **Sleep mode**

In Sleep mode, only the CPU is stopped. All peripherals continue to operate and can wake up the CPU when an interrupt/event occurs.

- **Stop mode**

Stop mode achieves very low power consumption while retaining the content of SRAM and registers. All clocks in the 1.8 V domain are stopped, the PLL, the HSI RC and the HSE crystal oscillators are disabled. The voltage regulator can also be put either in normal or in low power mode.

The device can be woken up from Stop mode by any of the EXTI lines. The EXTI line source can be one of the 16 external lines, the PVD output, RTC alarm, I2C1, USART1 or the CEC.

The I2C1, USART1 and the CEC can be configured to enable the HSI RC oscillator for processing incoming data. If this is used when the voltage regulator is put in low power mode, the regulator is first switched to normal mode before the clock is provided to the given peripheral.

- **Standby mode**

The Standby mode is used to achieve the lowest power consumption. The internal voltage regulator is switched off so that the entire 1.8 V domain is powered off. The PLL, the HSI RC and the HSE crystal oscillators are also switched off. After entering Standby mode, SRAM and register contents are lost except for registers in the RTC domain and Standby circuitry.

The device exits Standby mode when an external reset (NRST pin), an IWDG reset, a rising edge on the WKUP pins, or an RTC event occurs.

*Note: The RTC, the IWDG, and the corresponding clock sources are not stopped by entering Stop or Standby mode.*

## 3.6 Clocks and startup

System clock selection is performed on startup, however the internal RC 8 MHz oscillator is selected as default CPU clock on reset. An external 4-32 MHz clock can be selected, in which case it is monitored for failure. If failure is detected, the system automatically switches back to the internal RC oscillator. A software interrupt is generated if enabled. Similarly, full interrupt management of the PLL clock entry is available when necessary (for example on failure of an indirectly used external crystal, resonator or oscillator).

Several prescalers allow the application to configure the frequency of the AHB and the APB domains. The maximum frequency of the AHB and the APB domains is 48 MHz.

Additionally, also the internal RC 48 MHz oscillator can be selected for system clock or PLL input source. This oscillator can be automatically fine-trimmed by the means of the CRS peripheral using the external synchronization.



Figure 2. Clock tree

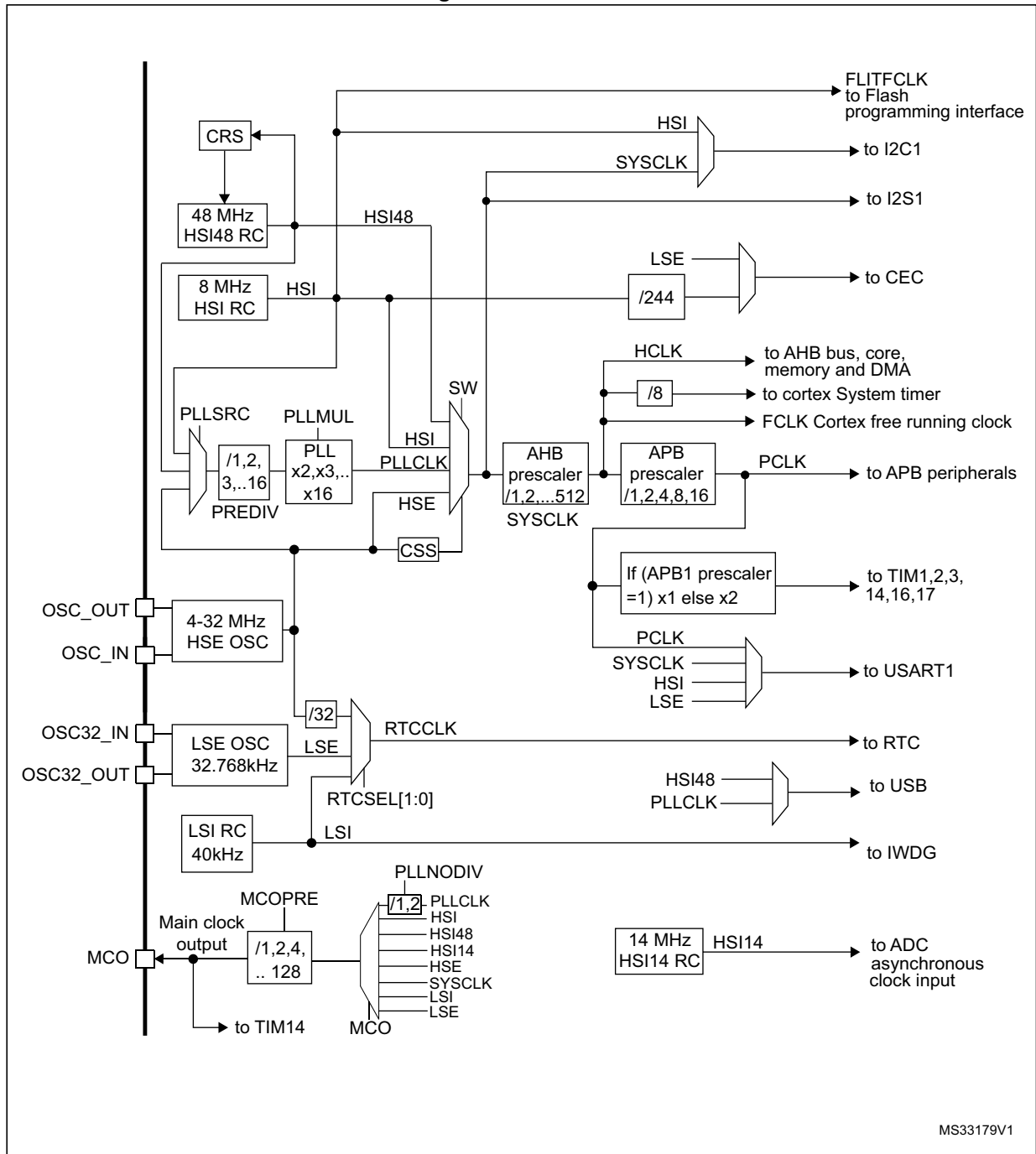

MS33179V1

### 3.7 General-purpose inputs/outputs (GPIOs)

Each of the GPIO pins can be configured by software as output (push-pull or open-drain), as input (with or without pull-up or pull-down) or as peripheral alternate function. Most of the GPIO pins are shared with digital or analog alternate functions.

The I/O configuration can be locked if needed following a specific sequence in order to avoid spurious writing to the I/Os registers.

### 3.8 Direct memory access controller (DMA)

The 5-channel general-purpose DMAs manage memory-to-memory, peripheral-to-memory and memory-to-peripheral transfers.

The DMA supports circular buffer management, removing the need for user code intervention when the controller reaches the end of the buffer.

Each channel is connected to dedicated hardware DMA requests, with support for software trigger on each channel. Configuration is made by software and transfer sizes between source and destination are independent.

DMA can be used with the main peripherals: SPI, I2S, I2C, USART, all TIMx timers (except TIM14) and ADC.

### 3.9 Interrupts and events

#### 3.9.1 Nested vectored interrupt controller (NVIC)

The STM32F0xx family embeds a nested vectored interrupt controller able to handle up to 32 maskable interrupt channels (not including the 16 interrupt lines of Cortex™-M0) and 4 priority levels.

- Closely coupled NVIC gives low latency interrupt processing
- Interrupt entry vector table address passed directly to the core
- Closely coupled NVIC core interface
- Allows early processing of interrupts
- Processing of late arriving higher priority interrupts
- Support for tail-chaining
- Processor state automatically saved
- Interrupt entry restored on interrupt exit with no instruction overhead

This hardware block provides flexible interrupt management features with minimal interrupt latency.

#### 3.9.2 Extended interrupt/event controller (EXTI)

The extended interrupt/event controller consists of 24 edge detector lines used to generate interrupt/event requests and wake-up the system. Each line can be independently configured to select the trigger event (rising edge, falling edge, both) and can be masked independently. A pending register maintains the status of the interrupt requests. The EXTI can detect an external line with a pulse width shorter than the internal clock period. Up to 38 GPIOs can be connected to the 16 external interrupt lines.

### 3.10 Analog to digital converter (ADC)

The 12-bit analog to digital converter has up to 10 external and 3 internal (temperature

sensor, voltage reference, VBAT voltage measurement) channels and performs conversions in single-shot or scan modes. In scan mode, automatic conversion is performed on a selected group of analog inputs.

The ADC can be served by the DMA controller.

An analog watchdog feature allows very precise monitoring of the converted voltage of one, some or all selected channels. An interrupt is generated when the converted voltage is outside the programmed thresholds.

### 3.10.1 Temperature sensor

The temperature sensor (TS) generates a voltage  $V_{SENSE}$  that varies linearly with temperature.

The temperature sensor is internally connected to the ADC\_IN16 input channel which is used to convert the sensor output voltage into a digital value.

The sensor provides good linearity but it has to be calibrated to obtain good overall accuracy of the temperature measurement. As the offset of the temperature sensor varies from chip to chip due to process variation, the uncalibrated internal temperature sensor is suitable for applications that detect temperature changes only.

To improve the accuracy of the temperature sensor measurement, each device is individually factory-calibrated by ST. The temperature sensor factory calibration data are stored by ST in the system memory area, accessible in read-only mode.

**Table 3. Temperature sensor calibration values**

Calibration value name	Description	Memory address
TS_CAL1	TS ADC raw data acquired at a temperature of 30 °C ( $\pm 5$ °C), $V_{DDA} = 3.3$ V ( $\pm 10$ mV)	0x1FFF F7B8 - 0x1FFF F7B9
TS_CAL2	TS ADC raw data acquired at a temperature of 110 °C ( $\pm 5$ °C), $V_{DDA} = 3.3$ V ( $\pm 10$ mV)	0x1FFF F7C2 - 0x1FFF F7C3

### 3.10.2 Internal voltage reference ( $V_{REFINT}$ )

The internal voltage reference ( $V_{REFINT}$ ) provides a stable (bandgap) voltage output for the ADC.  $V_{REFINT}$  is internally connected to the ADC\_IN17 input channel. The precise voltage of  $V_{REFINT}$  is individually measured for each part by ST during production test and stored in the system memory area. It is accessible in read-only mode.

**Table 4. Internal voltage reference calibration values**

Calibration value name	Description	Memory address
VREFINT_CAL	Raw data acquired at a temperature of 30 °C ( $\pm 5$ °C), $V_{DDA} = 3.3$ V ( $\pm 10$ mV)	0x1FFF F7BA - 0x1FFF F7BB

### 3.10.3 $V_{BAT}$ battery voltage monitoring

This embedded hardware feature allows the application to measure the  $V_{BAT}$  battery voltage using the internal ADC channel ADC\_IN18. As the  $V_{BAT}$  voltage may be higher than  $V_{DDA}$ , and thus outside the ADC input range, the  $V_{BAT}$  pin is internally connected to a bridge divider by 2. As a consequence, the converted digital value is half the  $V_{BAT}$  voltage.

## 3.11 Touch sensing controller (TSC)

The STM32F042x devices provide a simple solution for adding capacitive sensing functionality to any application. These devices offer up to 14 capacitive sensing channels distributed over 5 analog I/O groups.

Capacitive sensing technology is able to detect the presence of a finger near a sensor which is protected from direct touch by a dielectric (glass, plastic...). The capacitive variation introduced by the finger (or any conductive object) is measured using a proven implementation based on a surface charge transfer acquisition principle. It consists of charging the sensor capacitance and then transferring a part of the accumulated charges into a sampling capacitor until the voltage across this capacitor has reached a specific threshold. To limit the CPU bandwidth usage, this acquisition is directly managed by the hardware touch sensing controller and only requires few external components to operate.

The touch sensing controller is fully supported by the STMTouch touch sensing firmware library, which is free to use and allows touch sensing functionality to be implemented reliably in the end application.

**Table 5. Capacitive sensing GPIOs available on STM32F042x devices**

Group	Capacitive sensing signal name	Pin name	Group	Capacitive sensing signal name	Pin name
1	TSC_G1_IO1	PA0	4	TSC_G4_IO1	PA9
	TSC_G1_IO2	PA1		TSC_G4_IO2	PA10
	TSC_G1_IO3	PA2		TSC_G4_IO3	PA11
	TSC_G1_IO4	PA3		TSC_G4_IO4	PA12
2	TSC_G2_IO1	PA4	5	TSC_G5_IO1	PB3
	TSC_G2_IO2	PA5		TSC_G5_IO2	PB4
	TSC_G2_IO3	PA6		TSC_G5_IO3	PB6
	TSC_G2_IO4	PA7		TSC_G5_IO4	PB7
3	TSC_G3_IO2	PB0			
	TSC_G3_IO3	PB1			
	TSC_G3_IO4	PB2			

Table 6. No. of capacitive sensing channels available on STM32F042x devices

Analog I/O group	Number of capacitive sensing channels				
	STM32F042Cx LQPF48 UQFPN48	STM32F042Tx WLCSP36	STM32F042Kx LQFP32 UQFPN32	STM32F042Gx UQFPN28	STM32F042Fx TSSOP20
G1	3	3	3	3	3
G2	3	3	3	3	3
G3	2	2	1 2	1	0
G4	3	3	3	1	1
G5	3	3	3	3	0
Number of capacitive sensing channels	14	14	13 14	11	7

### 3.12 Timers and watchdogs

The STM32F042x devices include up to five general-purpose timers and an advanced control timer.

[Table 7](#) compares the features of the advanced-control and general-purpose timers.

Table 7. Timer feature comparison

Timer type	Timer	Counter resolution	Counter type	Prescaler factor	DMA request generation	Capture/compare channels	Complementary outputs
Advanced control	TIM1	16-bit	Up, down, up/down	Any integer between 1 and 65536	Yes	4	Yes
General purpose	TIM2	32-bit	Up, down, up/down	Any integer between 1 and 65536	Yes	4	No
	TIM3	16-bit	Up, down, up/down	Any integer between 1 and 65536	Yes	4	No
	TIM14	16-bit	Up	Any integer between 1 and 65536	No	1	No
	TIM16, TIM17	16-bit	Up	Any integer between 1 and 65536	Yes	1	Yes

### 3.12.1 Advanced-control timer (TIM1)

The advanced-control timer (TIM1) can be seen as a three-phase PWM multiplexed on six channels. It has complementary PWM outputs with programmable inserted dead times. It can also be seen as a complete general-purpose timer. The four independent channels can be used for:

- Input capture
- Output compare
- PWM generation (edge or center-aligned modes)
- One-pulse mode output

If configured as a standard 16-bit timer, it has the same features as the TIMx timer. If configured as the 16-bit PWM generator, it has full modulation capability (0-100%).

The counter can be frozen in debug mode.

Many features are shared with those of the standard timers which have the same architecture. The advanced control timer can therefore work together with the other timers via the Timer Link feature for synchronization or event chaining.

### 3.12.2 General-purpose timers (TIM2..3, TIM14, 16, 17)

There are five synchronizable general-purpose timers embedded in the STM32F042x devices (see [Table 7](#) for differences). Each general-purpose timer can be used to generate PWM outputs, or as simple time base.

#### TIM2, TIM3

STM32F042x devices feature two synchronizable 4-channel general-purpose timers. TIM2 is based on a 32-bit auto-reload up/downcounter and a 16-bit prescaler. TIM3 is based on a 16-bit auto-reload up/downcounter and a 16-bit prescaler. They feature 4 independent channels each for input capture/output compare, PWM or one-pulse mode output. This gives up to 12 input captures/output compares/PWMs on the largest packages.

The TIM2 and TIM3 general-purpose timers can work together or with the TIM1 advanced-control timer via the Timer Link feature for synchronization or event chaining.

TIM2 and TIM3 both have independent DMA request generation.

These timers are capable of handling quadrature (incremental) encoder signals and the digital outputs from 1 to 3 hall-effect sensors.

Their counters can be frozen in debug mode.

#### TIM14

This timer is based on a 16-bit auto-reload upcounter and a 16-bit prescaler.

TIM14 features one single channel for input capture/output compare, PWM or one-pulse mode output.

Its counter can be frozen in debug mode.

#### TIM16 and TIM17

Both timers are based on a 16-bit auto-reload upcounter and a 16-bit prescaler.

They each have a single channel for input capture/output compare, PWM or one-pulse mode output.

The TIM16 and TIM17 timers can work together via the Timer Link feature for synchronization or event chaining.

TIM16 and TIM17 have a complementary output with dead-time generation and independent DMA request generation.

Their counters can be frozen in debug mode.

### 3.12.3 Independent watchdog (IWDG)

The independent watchdog is based on an 8-bit prescaler and 12-bit downcounter with user-defined refresh window. It is clocked from an independent 40 kHz internal RC and as it operates independently from the main clock, it can operate in Stop and Standby modes. It can be used either as a watchdog to reset the device when a problem occurs, or as a free running timer for application timeout management. It is hardware or software configurable through the option bytes. The counter can be frozen in debug mode.

### 3.12.4 System window watchdog (WWDG)

The system window watchdog is based on a 7-bit downcounter that can be set as free running. It can be used as a watchdog to reset the device when a problem occurs. It is clocked from the APB clock (PCLK). It has an early warning interrupt capability and the counter can be frozen in debug mode.

### 3.12.5 SysTick timer

This timer is dedicated to real-time operating systems, but could also be used as a standard down counter. It features:

- A 24-bit down counter
- Autoreload capability
- Maskable system interrupt generation when the counter reaches 0
- Programmable clock source (HCLK or HCLK/8)

## 3.13 Real-time clock (RTC) and backup registers

The RTC and the 5 backup registers are supplied through a switch that takes power either on  $V_{DD}$  supply when present or through the  $V_{BAT}$  pin. The backup registers are five 32-bit registers used to store 20 bytes of user application data when  $V_{DD}$  power is not present. They are not reset by a system or power reset, or when the device wakes up from Standby mode.

The RTC is an independent BCD timer/counter. Its main features are the following:

- Calendar with subseconds, seconds, minutes, hours (12 or 24 format), week day, date, month, year, in BCD (binary-coded decimal) format.
- Automatically correction for 28, 29 (leap year), 30, and 31 day of the month.
- Programmable alarm with wake up from Stop and Standby mode capability.
- On-the-fly correction from 1 to 32767 RTC clock pulses. This can be used to synchronize it with a master clock.
- Digital calibration circuit with 1 ppm resolution, to compensate for quartz crystal inaccuracy.
- 2 anti-tamper detection pins with programmable filter. The MCU can be woken up from Stop and Standby modes on tamper event detection.
- Timestamp feature which can be used to save the calendar content. This function can be triggered by an event on the timestamp pin, or by a tamper event. The MCU can be woken up from Stop and Standby modes on timestamp event detection.
- Reference clock detection: a more precise second source clock (50 or 60 Hz) can be used to enhance the calendar precision.

The RTC clock sources can be:

- A 32.768 kHz external crystal
- A resonator or oscillator
- The internal low-power RC oscillator (typical frequency of 40 kHz)
- The high-speed external clock divided by 32

### 3.14 Inter-integrated circuit interfaces (I<sup>2</sup>C)

The I<sup>2</sup>C interface (I2C1) can operate in multimaster or slave modes. It can support Standard mode (up to 100 kbit/s), Fast mode (up to 400 kbit/s) and Fast Mode Plus (up to 1 Mbit/s) with 20 mA output drive on some I/Os.

It supports 7-bit and 10-bit addressing modes, multiple 7-bit slave addresses (2 addresses, 1 with configurable mask). It also includes programmable analog and digital noise filters.

**Table 8. Comparison of I2C analog and digital filters**

	Analog filter	Digital filter
Pulse width of suppressed spikes	≥ 50 ns	Programmable length from 1 to 15 I2C peripheral clocks
Benefits	Available in Stop mode	1. Extra filtering capability vs. standard requirements. 2. Stable length
Drawbacks	Variations depending on temperature, voltage, process	Wakeup from Stop on address match is not available when digital filter is enabled.

In addition, I2C1 provides hardware support for SMBUS 2.0 and PMBUS 1.1: ARP capability, Host notify protocol, hardware CRC (PEC) generation/verification, timeouts verifications and ALERT protocol management. I2C1 also has a clock domain independent



from the CPU clock, allowing the I2C1 to wake up the MCU from Stop mode on address match.

The I2C interface can be served by the DMA controller.

**Table 9. STM32F042x I<sup>2</sup>C implementation**

I2C features <sup>(1)</sup>	I2C1
7-bit addressing mode	X
10-bit addressing mode	X
Standard mode (up to 100 kbit/s)	X
Fast mode (up to 400 kbit/s)	X
Fast Mode Plus with 20mA output drive I/Os (up to 1 Mbit/s)	X
Independent clock	X
SMBus	X
Wakeup from STOP	X

1. X = supported.

### 3.15 Universal synchronous/asynchronous receiver transmitters (USART)

The device embeds up to two universal synchronous/asynchronous receiver transmitters (USART1 and USART2), which communicate at speeds of up to 6 Mbit/s.

They provide hardware management of the CTS, RTS and RS485 DE signals, multiprocessor communication mode, master synchronous communication and single-wire half-duplex communication mode. USART1 supports also SmartCard communication (ISO 7816), IrDA SIR ENDEC, LIN Master/Slave capability and auto baud rate feature, and has a clock domain independent from the CPU clock, allowing USART1 to wake up the MCU from Stop mode.

The USART interfaces can be served by the DMA controller.

Refer to [Table 10](#) for the differences between USART1 and USART2.

**Table 10. STM32F042x USART implementation**

USART modes/features <sup>(1)</sup>	USART1	USART2
Hardware flow control for modem	X	X
Continuous communication using DMA	X	X
Multiprocessor communication	X	X
Synchronous mode	X	X
Smartcard mode	X <sup>(2)</sup>	
Single-wire half-duplex communication	X	X
IrDA SIR ENDEC block	X	

**Table 10. STM32F042x USART implementation (continued)**

USART modes/features <sup>(1)</sup>	USART1	USART2
LIN mode	X	
Dual clock domain and wakeup from Stop mode	X	
Receiver timeout interrupt	X	
Modbus communication	X	
Auto baud rate detection	X	
Driver Enable	X	X

1. X = supported.
2. USART1\_CK is not available on 20/28 pin packages. Another source of clock (for example timer output programmed to the desired clock frequency) is needed to clock the card.

### 3.16 Serial peripheral interface (SPI)/Inter-integrated sound interfaces (I<sup>2</sup>S)

Up to two SPIs are able to communicate up to 18 Mbits/s in slave and master modes in full-duplex and half-duplex communication modes. The 3-bit prescaler gives 8 master mode frequencies and the frame size is configurable from 4 bits to 16 bits.

One standard I<sup>2</sup>S interface (multiplexed with SPI1) supporting four different audio standards can operate as master or slave at half-duplex communication mode. It can be configured to transfer 16 and 24 or 32 bits with 16-bit or 32-bit data resolution and synchronized by a specific signal. Audio sampling frequency from 8 kHz up to 192 kHz can be set by an 8-bit programmable linear prescaler. When operating in master mode, it can output a clock for an external audio component at 256 times the sampling frequency.

Refer to [Table 11](#) for the differences between SPI1 and SPI2.

**Table 11. STM32F042x SPI/I2S implementation**

SPI features <sup>(1)</sup>	SPI1	SPI2
Hardware CRC calculation	X	X
Rx/Tx FIFO	X	X
NSS pulse mode	X	X
I2S mode	X	
TI mode	X	X

1. X = supported.

### 3.17 High-definition multimedia interface (HDMI) - consumer electronics control (CEC)

The device embeds a HDMI-CEC controller that provides hardware support for the Consumer Electronics Control (CEC) protocol (Supplement 1 to the HDMI standard).

This protocol provides high-level control functions between all audiovisual products in an environment. It is specified to operate at low speeds with minimum processing and memory overhead. It has a clock domain independent from the CPU clock, allowing the HDMI\_CEC controller to wakeup the MCU from Stop mode on data reception.

### 3.18 Controller area network (CAN)

The CAN is compliant with specifications 2.0A and B (active) with a bit rate up to 1 Mbit/s. It can receive and transmit standard frames with 11-bit identifiers as well as extended frames with 29-bit identifiers. It has three transmit mailboxes, two receive FIFOs with 3 stages and 14 scalable filter banks.

### 3.19 Universal serial bus (USB)

The STM32F042x embeds a full-speed USB device peripheral compliant with the USB specification version 2.0. The internal USB PHY supports USB FS signaling, embedded DP pull-up and also battery charging detection according to Battery Charging Specification Revision 1.2. The USB interface implements a full-speed (12 Mbit/s) function interface with added support for USB 2.0 Link Power Management. It has software-configurable endpoint setting with packet memory up-to 1 KB (the last 256 bytes are used for CAN peripheral if enabled) and suspend/resume support. It requires a precise 48 MHz clock which can be generated from the internal main PLL (the clock source must use an HSE crystal oscillator) or by the internal 48 MHz oscillator in automatic trimming mode. The synchronization for this oscillator can be taken from the USB data stream itself (SOF signalization) which allows crystal-less operation.

### 3.20 Clock recovery system (CRS)

The STM32F042x embeds a special block which allows automatic trimming of the internal 48 MHz oscillator to guarantee its optimal accuracy over the whole device operational range. This automatic trimming is based on the external synchronization signal, which could be either derived from USB SOF signalization, from LSE oscillator, from an external signal on CRS\_SYNC pin or generated by user software. For faster lock-in during startup it is also possible to combine automatic trimming with manual trimming action.

### 3.21 Serial wire debug port (SW-DP)

An ARM SW-DP interface is provided to allow a serial wire debugging tool to be connected to the MCU.

# 4 Pinouts and pin descriptions

Figure 3. LQFP48 48-pin package pinout (top view)

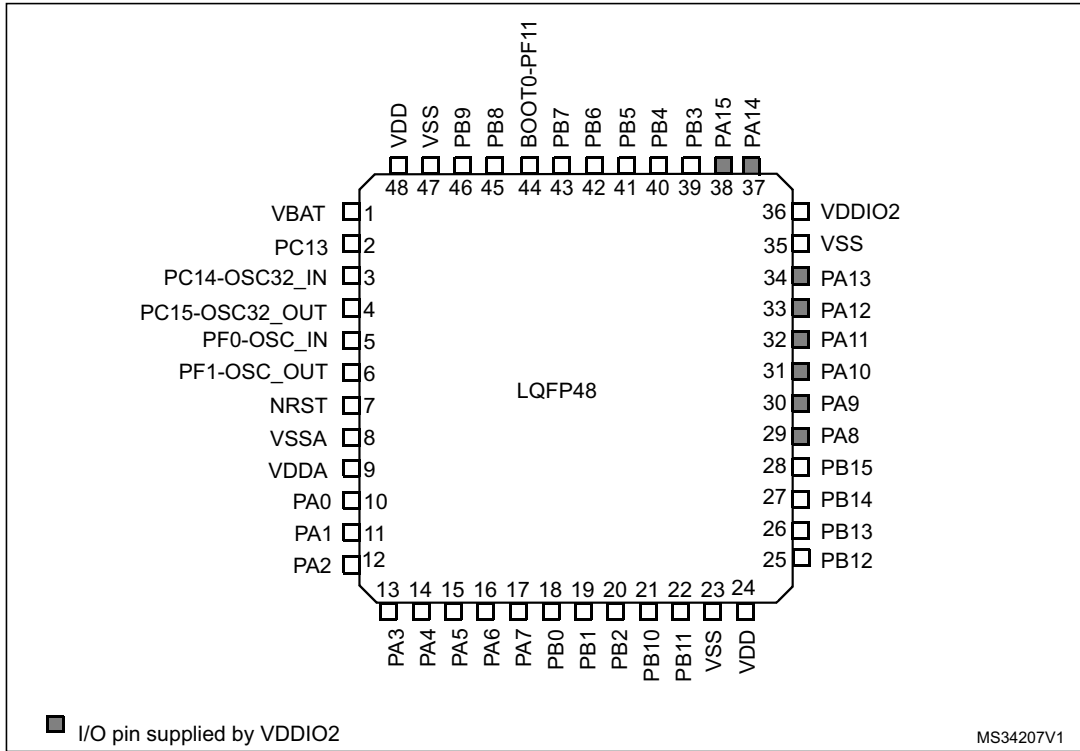

Figure 4. UFQFPN48 48-pin package pinout (top view)

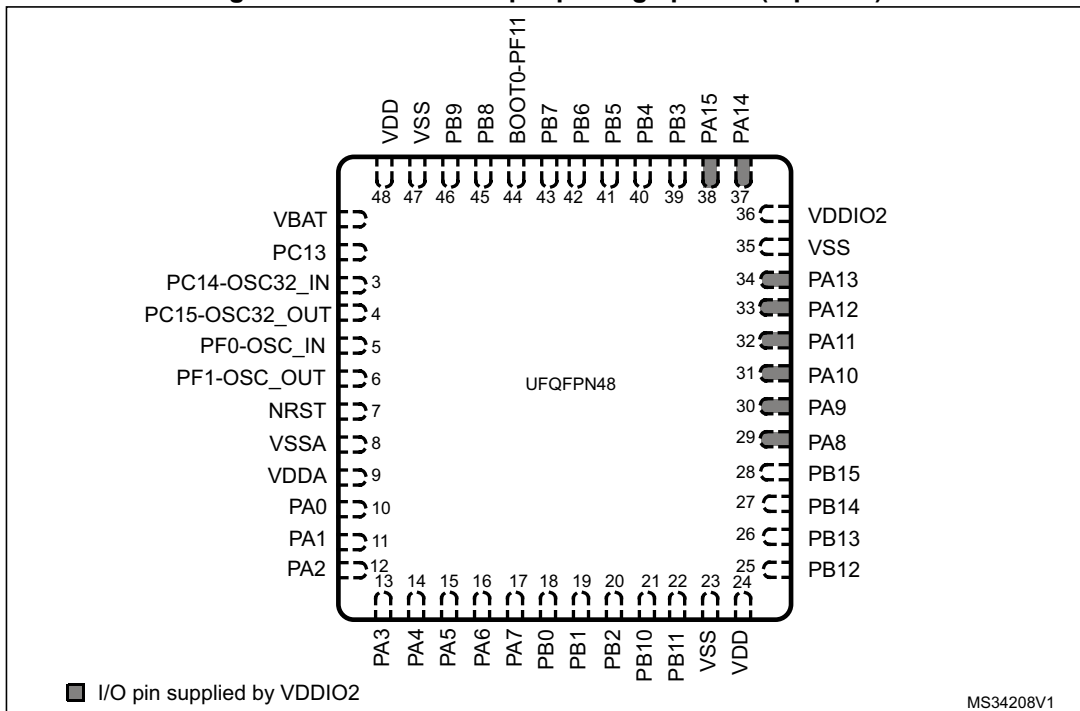

Figure 5. WLCSP36 36-pin package ball-out

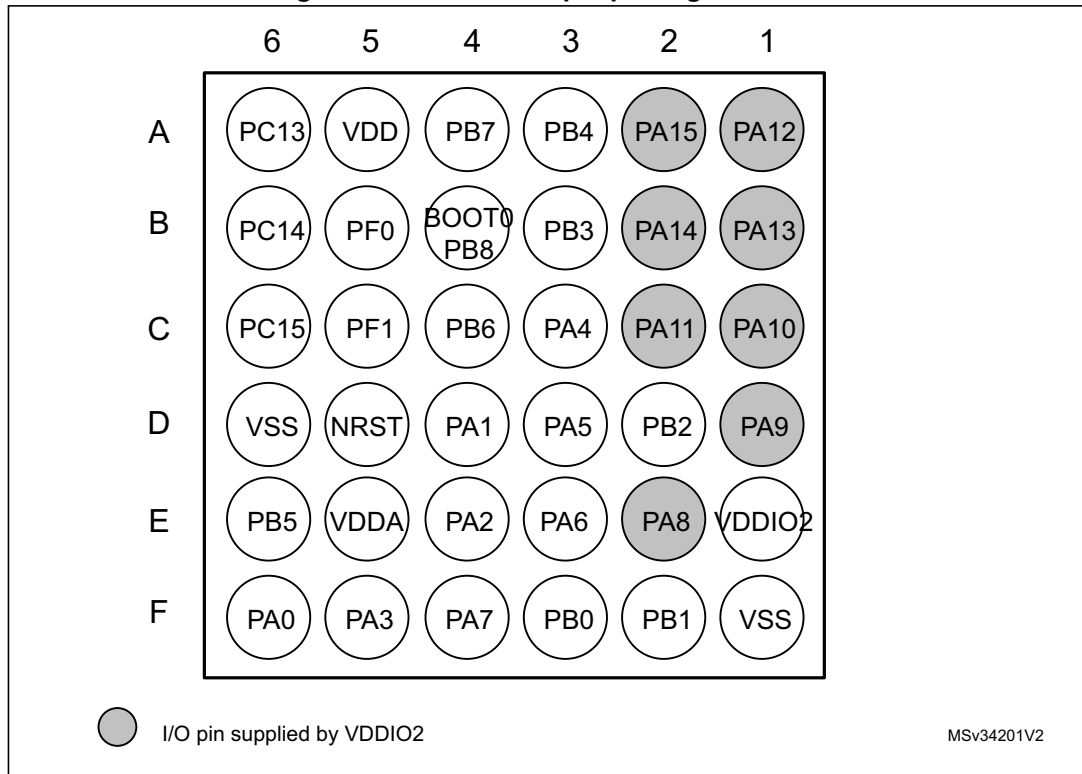

Figure 6. LQFP32 32-pin package pinout (top view)

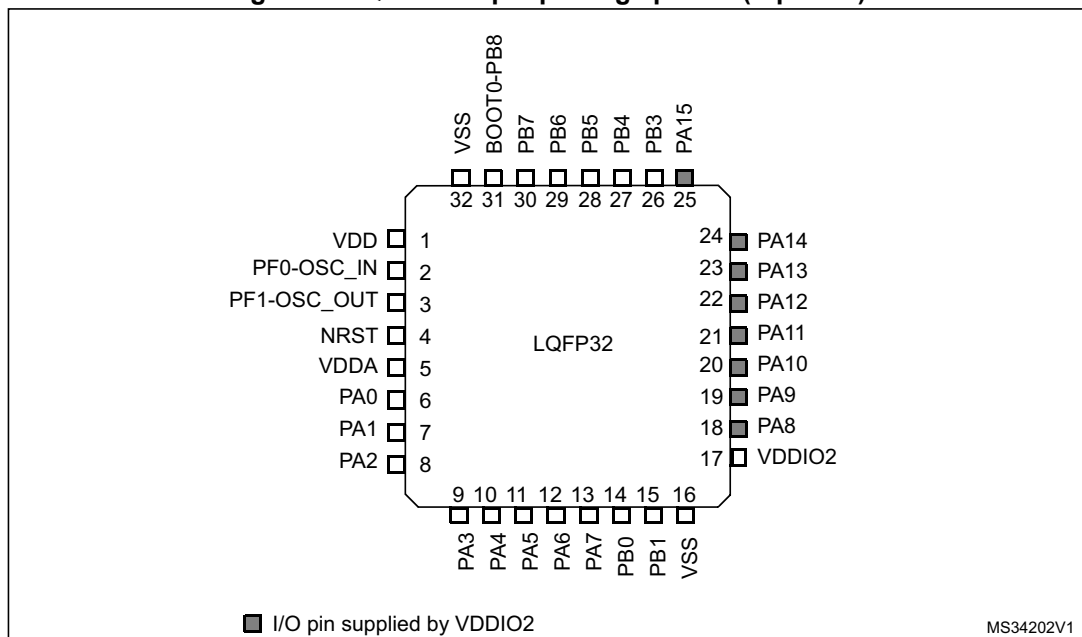

Figure 7. UFQFPN32 32-pin package pinout (top view)

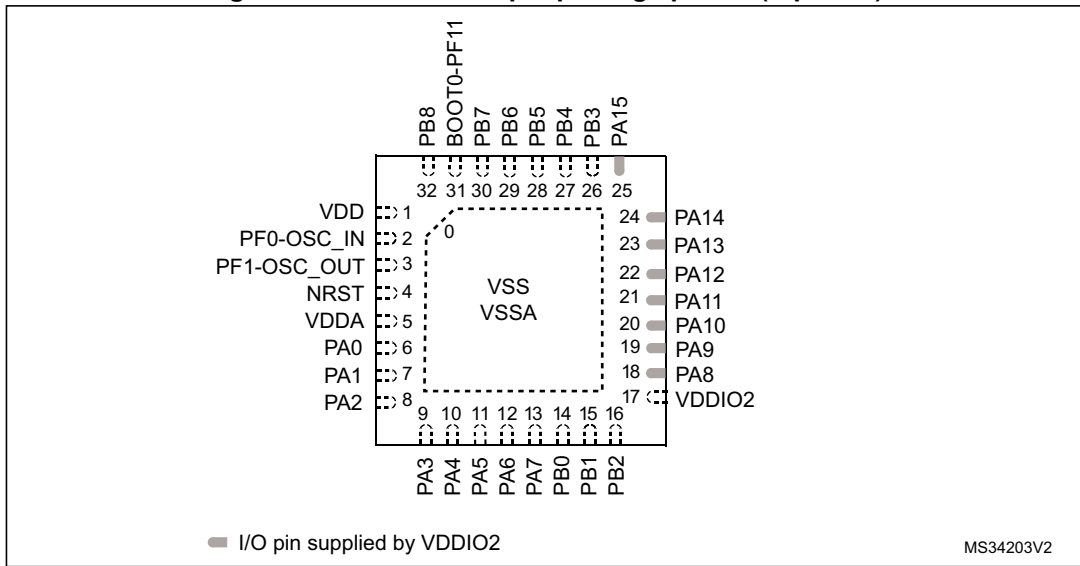
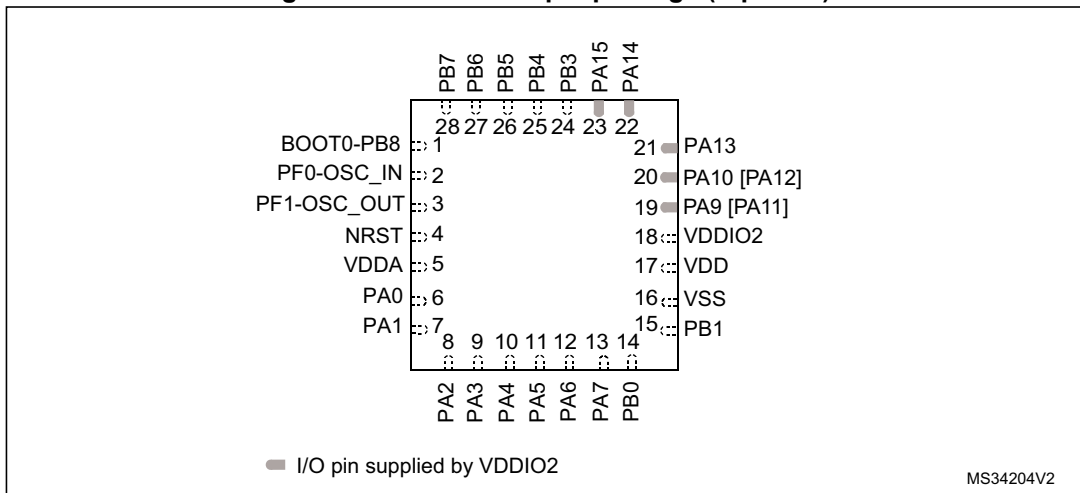
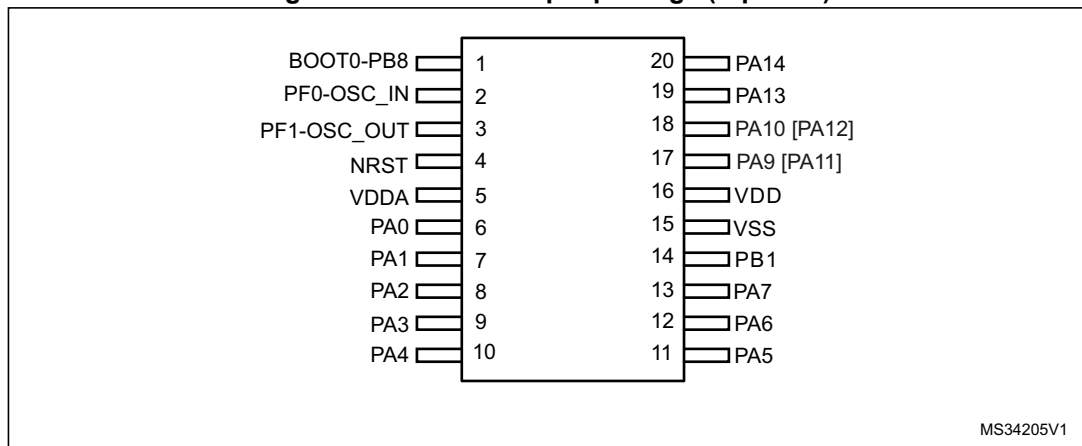

Figure 8. UQFPN28 28-pin package (top view)



1. Pin pair PA11/12 can be remapped instead of pin pair PA9/10 using the SYSCFG\_CFGR1 register.

Figure 9. TSSOP20 20-pin package (top view)



1. Pin pair PA11/12 can be remapped instead of pin pair PA9/10 using the SYSCFG\_CFGR1 register.

Table 12. Legend/abbreviations used in the pinout table

Name		Abbreviation	Definition
Pin name		Unless otherwise specified in brackets below the pin name, the pin function during and after reset is the same as the actual pin name	
Pin type		S	Supply pin
		I	Input only pin
		I/O	Input / output pin
I/O structure		FT	5 V tolerant I/O
		FTf	5 V tolerant I/O, FM+ capable
		TTa	3.3 V tolerant I/O directly connected to ADC
		TC	Standard 3.3 V I/O
		RST	Bidirectional reset pin with embedded weak pull-up resistor
Notes		Unless otherwise specified by a note, all I/Os are set as floating inputs during and after reset.	
Pin functions	Alternate functions	Functions selected through GPIOx_AFR registers	
	Additional functions	Functions directly selected/enabled through peripheral registers	



Table 13. STM32F042x pin definitions

Pin numbers						Pin name (function after reset)	Pin type	I/O structure	Notes	Pin functions	
LQFP48/UFQFPN48	WLCSP36	LQFP32	UFQFPN32	UFQFPN28	TSSPOP20					Alternate function	Additional functions
1	-	-	-	-	-	VBAT	S	-	-	Backup power supply	
2	A6	-	-	-	-	PC13	I/O	TC	(1) (2)	-	WKUP2, RTC_TAMP1, RTC_TS, RTC_OUT
3	B6	-	-	-	-	PC14- OSC32_IN (PC14)	I/O	TC	(1) (2)	-	OSC32_IN
4	C6	-	-	-	-	PC15- OSC32_OUT (PC15)	I/O	TC	(1) (2)	-	OSC32_OUT
5	B5	2	2	2	2	PF0-OSC_IN (PF0)	I/O	FTf	-	CRS_SYNC I2C1_SDA	OSC_IN
6	C5	3	3	3	3	PF1-OSC_OUT (PF1)	I/O	FTf	-	I2C1_SCL	OSC_OUT
7	D5	4	4	4	4	NRST	I/O	RST	-	Device reset input / internal reset output (active low)	
8	D6	32	0	16	15	VSSA	S	-	-	Analog ground	
9	E5	5	5	5	5	VDDA	S	-	-	Analog power supply	
10	F6	6	6	6	6	PA0	I/O	TTa	-	USART2_CTS, TIM2_CH1_ETR, TSC_G1_IO1	RTC_ TAMP2, WKUP1, ADC_IN0,
11	D4	7	7	7	7	PA1	I/O	TTa	-	USART2_RTS, TIM2_CH2, TSC_G1_IO2, EVENTOUT	ADC_IN1
12	E4	8	8	8	8	PA2	I/O	TTa	-	USART2_TX, TIM2_CH3, TSC_G1_IO3	ADC_IN2, WKUP4
13	F5	9	9	9	9	PA3	I/O	TTa	-	USART2_RX, TIM2_CH4, TSC_G1_IO4	ADC_IN3

Table 13. STM32F042x pin definitions (continued)

Pin numbers						Pin name (function after reset)	Pin type	I/O structure	Notes	Pin functions	
LQFP48/UFQFPN48	WLCSP36	LQFP32	UFQFPN32	UFQFPN28	TSSPOP20					Alternate function	Additional functions
14	C3	10	10	10	10	PA4	I/O	TTa	-	SPI1_NSS, I2S1_WS, TIM14_CH1, TSC_G2_IO1, USART2_CK USB_NOE	ADC_IN4
15	D3	11	11	11	11	PA5	I/O	TTa	-	SPI1_SCK, I2S1_CK, CEC, TIM2_CH1_ETR, TSC_G2_IO2	ADC_IN5
16	E3	12	12	12	12	PA6	I/O	TTa	-	SPI1_MISO, I2S1_MCK, TIM3_CH1, TIM1_BKIN, TIM16_CH1, TSC_G2_IO3, EVENTOUT	ADC_IN6
17	F4	13	13	13	13	PA7	I/O	TTa	-	SPI1_MOSI, I2S1_SD, TIM3_CH2, TIM14_CH1, TIM1_CH1N, TIM17_CH1, TSC_G2_IO4, EVENTOUT	ADC_IN7
18	F3	14	14	14	-	PB0	I/O	TTa	-	TIM3_CH3, TIM1_CH2N, TSC_G3_IO2, EVENTOUT	ADC_IN8
19	F2	15	15	15	14	PB1	I/O	TTa	-	TIM3_CH4, TIM14_CH1, TIM1_CH3N, TSC_G3_IO3	ADC_IN9
20	D2	-	16	-	-	PB2	I/O	FT	-	TSC_G3_IO4	-
21	-	-	-	-	-	PB10	I/O	FTf	-	SPI2_SCK, CEC, TSC_SYNC, TIM2_CH3, I2C1_SCL	-
22	-	-	-	-	-	PB11	I/O	FTf	-	TIM2_CH4, EVENTOUT, I2C1_SDA	-
23	F1	16	0	16	15	VSS	S	-	-	Ground	
24	-	-	-	17	16	VDD	S	-	-	Digital power supply	
25	-	-	-	-	-	PB12	I/O	FT	-	TIM1_BKIN, SPI2_NSS, EVENTOUT	-

Table 13. STM32F042x pin definitions (continued)

Pin numbers						Pin name (function after reset)	Pin type	I/O structure	Notes	Pin functions	
LQFP48/UFQFPN48	WLCSP36	LQFP32	UFQFPN32	UFQFPN28	TSSPOP20					Alternate function	Additional functions
26	-	-	-	-	-	PB13	I/O	FTf	-	SPI2_SCK, TIM1_CH1N, I2C1_SCL	-
27	-	-	-	-	-	PB14	I/O	FTf	-	SPI2_MISO, TIM1_CH2N, I2C1_SDA	-
28	-	-	-	-	-	PB15	I/O	FT	-	SPI2_MOSI, TIM1_CH3N	WKUP7, RTC_REFIN
29	E2	18	18	-	-	PA8	I/O	FT	(3)	USART1_CK, TIM1_CH1, EVENTOUT, MCO, CRS_SYNC	-
30	D1	19	19	19	17	PA9	I/O	FTf	(3)	USART1_TX, TIM1_CH2, TSC_G4_IO1, I2C1_SCL	-
31	C1	20	20	20	18	PA10	I/O	FTf	(3)	USART1_RX, TIM1_CH3, TIM17_BKIN, TSC_G4_IO2, I2C1_SDA	-
32	C2	21	21	19 <sup>(4)</sup>	17 <sup>(4)</sup>	PA11	I/O	FTf	(3)	CAN_RX, USART1_CTS, TIM1_CH4, COMP1_OUT, TSC_G4_IO3, EVENTOUT, I2C1_SCL	USB_DM
33	A1	22	22	20 <sup>(4)</sup>	18 <sup>(4)</sup>	PA12	I/O	FTf	(3)	CAN_TX, USART1_RTS, TIM1_ETR, TSC_G4_IO4, EVENTOUT, I2C1_SDA	USB_DP
34	B1	23	23	21	19	PA13	I/O	FT	(3) (5)	IR_OUT, SWDIO USB_NOE	-
35	-	-	-	-	-	VSS	S	-	-	Ground	
36	E1	17	17	18	16	VDDIO2	S	-	-	Digital power supply	

Table 13. STM32F042x pin definitions (continued)

Pin numbers						Pin name (function after reset)	Pin type	I/O structure	Notes	Pin functions	
LQFP48/UFQFPN48	WLCSP36	LQFP32	UFQFPN32	UFQFPN28	TSSPOP20					Alternate function	Additional functions
37	B2	24	24	22	20	PA14	I/O	FT	(3) (5)	USART2_TX, SWCLK	-
38	A2	25	25	23	-	PA15	I/O	FT	(3)	SPI1_NSS, I2S1_WS, USART2_RX, TIM2_CH1_ETR, EVENTOUT, USB_NOE	-
39	B3	26	26	24	-	PB3	I/O	FT	-	SPI1_SCK, I2S1_CK, TIM2_CH2, TSC_G5_IO1, EVENTOUT	-
40	A3	27	27	25	-	PB4	I/O	FT	-	SPI1_MISO, I2S1_MCK, TIM17_BKIN, TIM3_CH1, TSC_G5_IO2, EVENTOUT	-
41	E6	28	28	26	-	PB5	I/O	FT	-	SPI1_MOSI, I2S1_SD, I2C1_SMBA, TIM16_BKIN, TIM3_CH2	WKUP6
42	C4	29	29	27	-	PB6	I/O	FTf	-	I2C1_SCL, USART1_TX, TIM16_CH1N, TSC_G5_IO3	-
43	A4	30	30	28	-	PB7	I/O	FTf	-	I2C1_SDA, USART1_RX, USART4_CTS, TIM17_CH1N, TSC_G5_IO4	-
44	-	-	31	-	-	PF11 BOOT0	I/O	FT	-	-	Boot memory selection
-	B4	31	-	1	1	PB8 BOOT0	I/O	FTf	-	I2C1_SCL, CEC, TIM16_CH1, TSC_SYNC, CAN_RX	Boot memory selection
45	-	-	32	-	-	PB8	I/O	FTf	-	I2C1_SCL, CEC, TIM16_CH1, TSC_SYNC, CAN_RX	-

Table 13. STM32F042x pin definitions (continued)

Pin numbers						Pin name (function after reset)	Pin type	I/O structure	Notes	Pin functions	
LQFP48/UFQFPN48	WLCSP36	LQFP32	UFQFPN32	UFQFPN28	TSSPOP20					Alternate function	Additional functions
46	-	-	-	-	-	PB9	I/O	FTf	-	SPI2_NSS, I2C1_SDA, IR_OUT, TIM17_CH1, EVENTOUT, CAN_TX	-
47	-	32	0	-	-	VSS	S	-	-	Ground	
48	A5	1	1	-	-	VDD	S	-	-	Digital power supply	

- PC13, PC14 and PC15 are supplied through the power switch. Since the switch only sinks a limited amount of current (3 mA), the use of GPIOs PC13 to PC15 in output mode is limited:
  - The speed should not exceed 2 MHz with a maximum load of 30 pF.
  - These GPIOs must not be used as current sources (e.g. to drive an LED).
- After the first RTC domain power-up, PC13, PC14 and PC15 operate as GPIOs. Their function then depends on the content of the RTC registers which are not reset by the system reset. For details on how to manage these GPIOs, refer to the RTC domain and RTC register descriptions in the reference manual.
- PA8, PA9, PA10, PA11, PA12, PA13, PA14 and PA15 I/Os are supplied by VDDIO2.
- Pin pair PA11/12 can be remapped instead of pin pair PA9/10 using SYSCFG\_CFGR1 register.
- After reset, these pins are configured as SWDIO and SWCLK alternate functions, and the internal pull-up on the SWDIO pin and the internal pull-down on the SWCLK pin are activated.



**Table 14. Alternate functions selected through GPIOA\_AFR registers for port A**

Pin name	AF0	AF1	AF2	AF3	AF4	AF5	AF6	AF7
PA0	-	USART2_CTS	TIM2_CH1_ETR	TSC_G1_IO1	-	-	-	-
PA1	EVENTOUT	USART2_RTS	TIM2_CH2	TSC_G1_IO2	-	-	-	-
PA2	-	USART2_TX	TIM2_CH3	TSC_G1_IO3	-	-	-	-
PA3	-	USART2_RX	TIM2_CH4	TSC_G1_IO4	-	-	-	-
PA4	SPI1_NSS, I2S1_WS	USART2_CK	USB_NOE	TSC_G2_IO1	TIM14_CH1	-	-	-
PA5	SPI1_SCK, I2S1_CK	CEC	TIM2_CH1_ETR	TSC_G2_IO2	-	-	-	-
PA6	SPI1_MISO, I2S1_MCK	TIM3_CH1	TIM1_BKIN	TSC_G2_IO3	-	TIM16_CH1	EVENTOUT	-
PA7	SPI1_MOSI, I2S1_SD	TIM3_CH2	TIM1_CH1N	TSC_G2_IO4	TIM14_CH1	TIM17_CH1	EVENTOUT	-
PA8	MCO	USART1_CK	TIM1_CH1	EVENTOUT	CRS_SYNC	-	-	-
PA9	-	USART1_TX	TIM1_CH2	TSC_G4_IO1	I2C1_SCL	MCO	-	-
PA10	TIM17_BKIN	USART1_RX	TIM1_CH3	TSC_G4_IO2	I2C1_SDA	-	-	-
PA11	EVENTOUT	USART1_CTS	TIM1_CH4	TSC_G4_IO3	CAN_RX	I2C1_SCL	-	-
PA12	EVENTOUT	USART1_RTS	TIM1_ETR	TSC_G4_IO4	CAN_TX	I2C1_SDA	-	-
PA13	SWDIO	IR_OUT	USB_NOE	-	-	-	-	-
PA14	SWCLK	USART2_TX	-	-	-	-	-	-
PA15	SPI1_NSS, I2S1_WS	USART2_RX	TIM2_CH1_ETR	EVENTOUT	-	USB_NOE	-	-

**Table 15. Alternate functions selected through GPIOB\_AFR registers for port B**

Pin name	AF0	AF1	AF2	AF3	AF4	AF5
PB0	EVENTOUT	TIM3_CH3	TIM1_CH2N	TSC_G3_IO2	-	-
PB1	TIM14_CH1	TIM3_CH4	TIM1_CH3N	TSC_G3_IO3	-	-
PB2	-	-	-	TSC_G3_IO4	-	-
PB3	SPI1_SCK, I2S1_CK	EVENTOUT	TIM2_CH2	TSC_G5_IO1	-	-
PB4	SPI1_MISO, I2S1_MCK	TIM3_CH1	EVENTOUT	TSC_G5_IO2	-	TIM17_BKIN
PB5	SPI1_MOSI, I2S1_SD	TIM3_CH2	TIM16_BKIN	I2C1_SMBA	-	-
PB6	USART1_TX	I2C1_SCL	TIM16_CH1N	TSC_G5_IO3	-	-
PB7	USART1_RX	I2C1_SDA	TIM17_CH1N	TSC_G5_IO4	-	-
PB8	CEC	I2C1_SCL	TIM16_CH1	TSC_SYNC	CAN_RX	-
PB9	IR_OUT	I2C1_SDA	TIM17_CH1	EVENTOUT	CAN_TX	SPI2_NSS
PB10	CEC	I2C1_SCL	TIM2_CH3	TSC_SYNC	-	SPI2_SCK
PB11	EVENTOUT	I2C1_SDA	TIM2_CH4	-	-	-
PB12	SPI2_NSS	EVENTOUT	TIM1_BKIN	-	-	-
PB13	SPI2_SCK	-	TIM1_CH1N	-	-	I2C2_SCL
PB14	SPI2_MISO	-	TIM1_CH2N	-	-	I2C2_SDA
PB15	SPI2_MOSI	-	TIM1_CH3N	-	-	-

**Table 16. Alternate functions selected through GPIOF\_AFR registers for port F**

Pin name	AF0	AF1
PF0	CRS_SYNC	I2C1_SDA
PF1	-	I2C1_SCL



# 5 Memory mapping

Figure 10. STM32F042x memory map

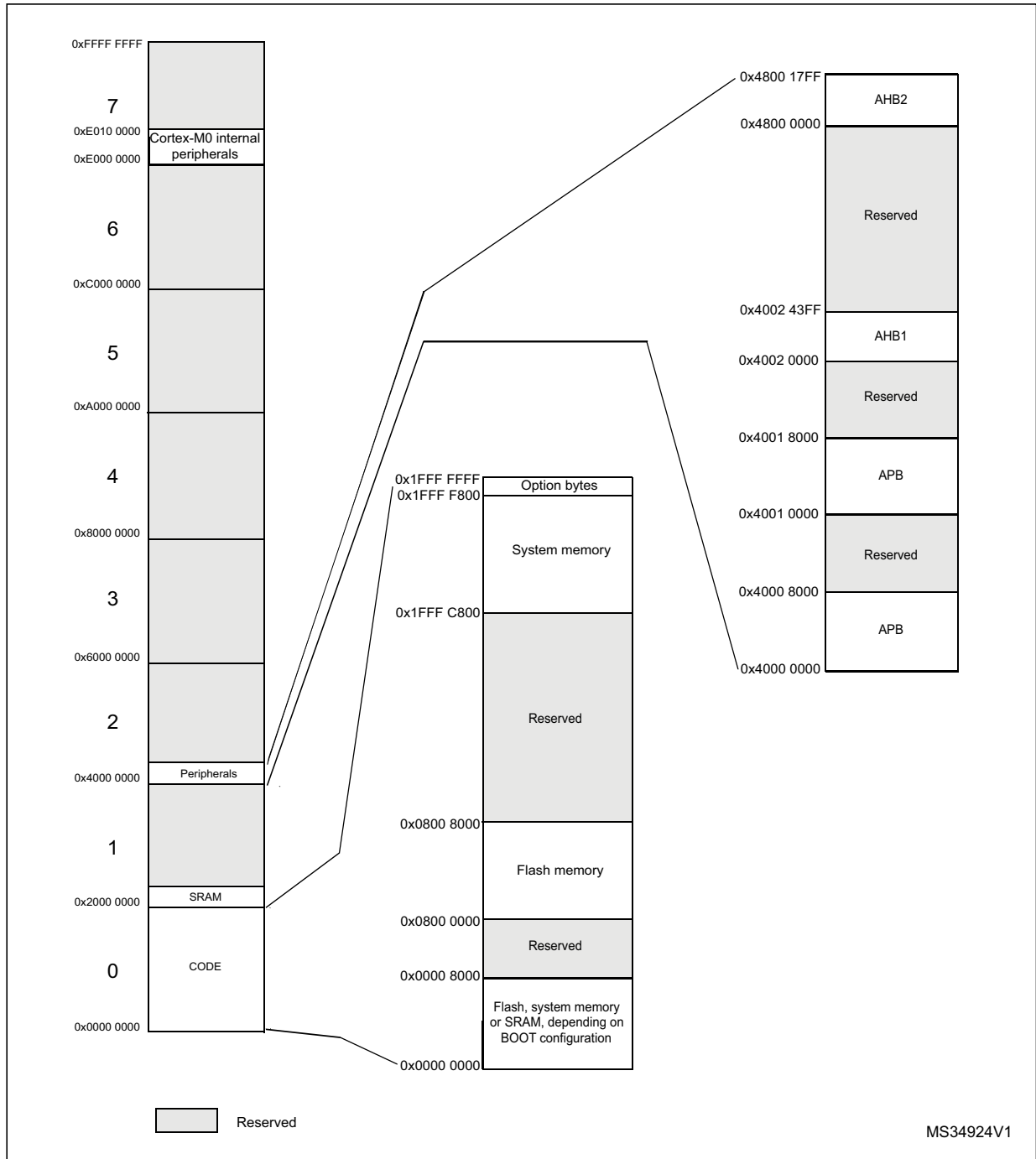

Table 17. STM32F042x peripheral register boundary addresses

Bus	Boundary address	Size	Peripheral
	0x4800 1800 - 0x5FFF FFFF	~384 MB	Reserved
AHB2	0x4800 1400 - 0x4800 17FF	1 KB	GPIOF
	0x4800 0C00 - 0x4800 13FF	2 KB	Reserved
	0x4800 0800 - 0x4800 0BFF	1 KB	GPIOC
	0x4800 0400 - 0x4800 07FF	1 KB	GPIOB
	0x4800 0000 - 0x4800 03FF	1 KB	GPIOA
	0x4002 4400 - 0x47FF FFFF	~128 MB	Reserved
AHB1	0x4002 4000 - 0x4002 43FF	1 KB	TSC
	0x4002 3400 - 0x4002 3FFF	3 KB	Reserved
	0x4002 3000 - 0x4002 33FF	1 KB	CRC
	0x4002 2400 - 0x4002 2FFF	3 KB	Reserved
	0x4002 2000 - 0x4002 23FF	1 KB	FLASH Interface
	0x4002 1400 - 0x4002 1FFF	3 KB	Reserved
	0x4002 1000 - 0x4002 13FF	1 KB	RCC
	0x4002 0400 - 0x4002 0FFF	3 KB	Reserved
	0x4002 0000 - 0x4002 03FF	1 KB	DMA
	0x4001 8000 - 0x4001 FFFF	32 KB	Reserved
APB	0x4001 5C00 - 0x4001 7FFF	9 KB	Reserved
	0x4001 5800 - 0x4001 5BFF	1 KB	DBGMCU
	0x4001 4C00 - 0x4001 57FF	3 KB	Reserved
	0x4001 4800 - 0x4001 4BFF	1 KB	TIM17
	0x4001 4400 - 0x4001 47FF	1 KB	TIM16
	0x4001 3C00 - 0x4001 43FF	2 KB	Reserved
	0x4001 3800 - 0x4001 3BFF	1 KB	USART1
	0x4001 3400 - 0x4001 37FF	1 KB	Reserved
	0x4001 3000 - 0x4001 33FF	1 KB	SPI1/I2S1
	0x4001 2C00 - 0x4001 2FFF	1 KB	TIM1
	0x4001 2800 - 0x4001 2BFF	1 KB	Reserved
	0x4001 2400 - 0x4001 27FF	1 KB	ADC
	0x4001 0800 - 0x4001 23FF	7 KB	Reserved
	0x4001 0400 - 0x4001 07FF	1 KB	EXTI
0x4001 0000 - 0x4001 03FF	1 KB	SYSCFG + COMP	
	0x4000 8000 - 0x4000 FFFF	32 KB	Reserved

Table 17. STM32F042x peripheral register boundary addresses (continued)

Bus	Boundary address	Size	Peripheral
APB	0x4000 7C00 - 0x4000 7FFF	1 KB	Reserved
	0x4000 7800 - 0x4000 7BFF	1 KB	CEC
	0x4000 7400 - 0x4000 77FF	1 KB	Reserved
	0x4000 7000 - 0x4000 73FF	1 KB	PWR
	0x4000 6C00 - 0x4000 6FFF	1 KB	CRS
	0x4000 6800 - 0x4000 6BFF0	1 KB	Reserved
	0x4000 6400 - 0x4000 67FF	1 KB	BxCAN
	0x4000 6000 - 0x4000 63FF	1 KB	USB/CAN RAM
	0x4000 5C00 - 0x4000 5FFF	1 KB	USB
	0x4000 5800 - 0x4000 5BFF	1 KB	Reserved
	0x4000 5400 - 0x4000 57FF	1 KB	I2C1
	0x4000 4800 - 0x4000 53FF	3 KB	Reserved
	0x4000 4400 - 0x4000 47FF	1 KB	USART2
	0x4000 3C00 - 0x4000 43FF	2 KB	Reserved
	0x4000 3800 - 0x4000 3BFF	1 KB	SPI2
	0x4000 3400 - 0x4000 37FF	1 KB	Reserved
	0x4000 3000 - 0x4000 33FF	1 KB	IWDG
	0x4000 2C00 - 0x4000 2FFF	1 KB	WWDG
	0x4000 2800 - 0x4000 2BFF	1 KB	RTC
	0x4000 2400 - 0x4000 27FF	1 KB	Reserved
	0x4000 2000 - 0x4000 23FF	1 KB	TIM14
	0x4000 0800 - 0x4000 1FFF	6 KB	Reserved
	0x4000 0400 - 0x4000 07FF	1 KB	TIM3
0x4000 0000 - 0x4000 03FF	1 KB	TIM2	

## 6 Electrical characteristics

### 6.1 Parameter conditions

Unless otherwise specified, all voltages are referenced to  $V_{SS}$ .

#### 6.1.1 Minimum and maximum values

Unless otherwise specified, the minimum and maximum values are guaranteed in the worst conditions of ambient temperature, supply voltage and frequencies by tests in production on 100% of the devices with an ambient temperature at  $T_A = 25\text{ }^\circ\text{C}$  and  $T_A = T_{Amax}$  (given by the selected temperature range).

Data based on characterization results, design simulation and/or technology characteristics are indicated in the table footnotes and are not tested in production. Based on characterization, the minimum and maximum values refer to sample tests and represent the mean value plus or minus three times the standard deviation (mean  $\pm 3\sigma$ ).

#### 6.1.2 Typical values

Unless otherwise specified, typical data are based on  $T_A = 25\text{ }^\circ\text{C}$ ,  $V_{DD} = V_{DDA} = 3.3\text{ V}$ . They are given only as design guidelines and are not tested.

Typical ADC accuracy values are determined by characterization of a batch of samples from a standard diffusion lot over the full temperature range, where 95% of the devices have an error less than or equal to the value indicated (mean  $\pm 2\sigma$ ).

#### 6.1.3 Typical curves

Unless otherwise specified, all typical curves are given only as design guidelines and are not tested.

#### 6.1.4 Loading capacitor

The loading conditions used for pin parameter measurement are shown in [Figure 11](#).

#### 6.1.5 Pin input voltage

The input voltage measurement on a pin of the device is described in [Figure 12](#).

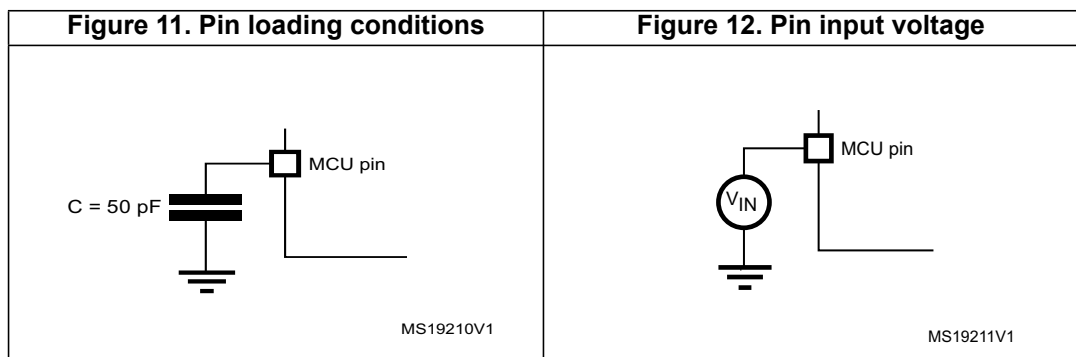

6.1.6 Power supply scheme

Figure 13. Power supply scheme

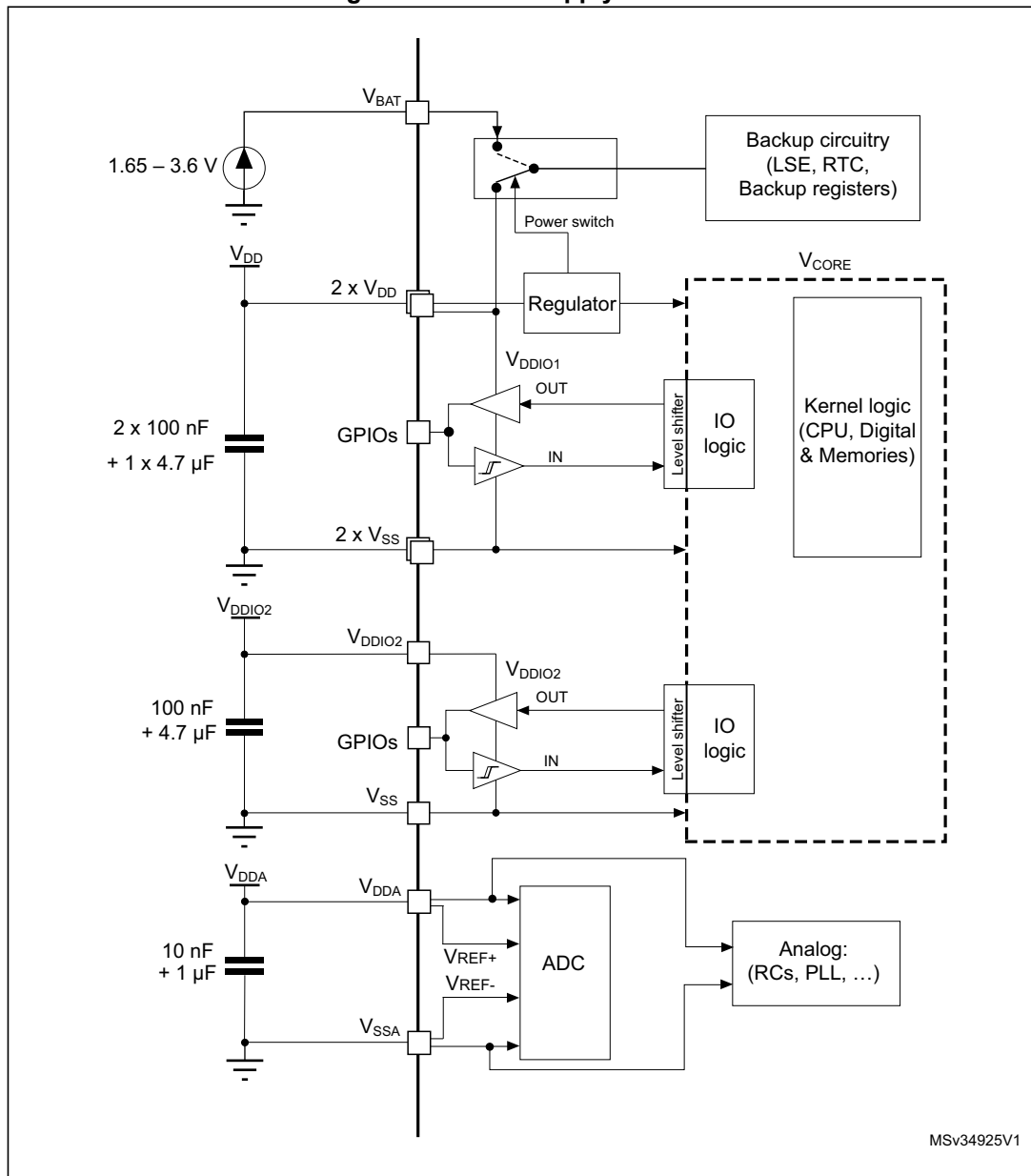

**Caution:** Each power supply pair ( $V_{DD}/V_{SS}$ ,  $V_{DDA}/V_{SSA}$  etc.) must be decoupled with filtering ceramic capacitors as shown above. These capacitors must be placed as close as possible to, or below, the appropriate pins on the underside of the PCB to ensure the good functionality of the device.

### 6.1.7 Current consumption measurement

Figure 14. Current consumption measurement scheme

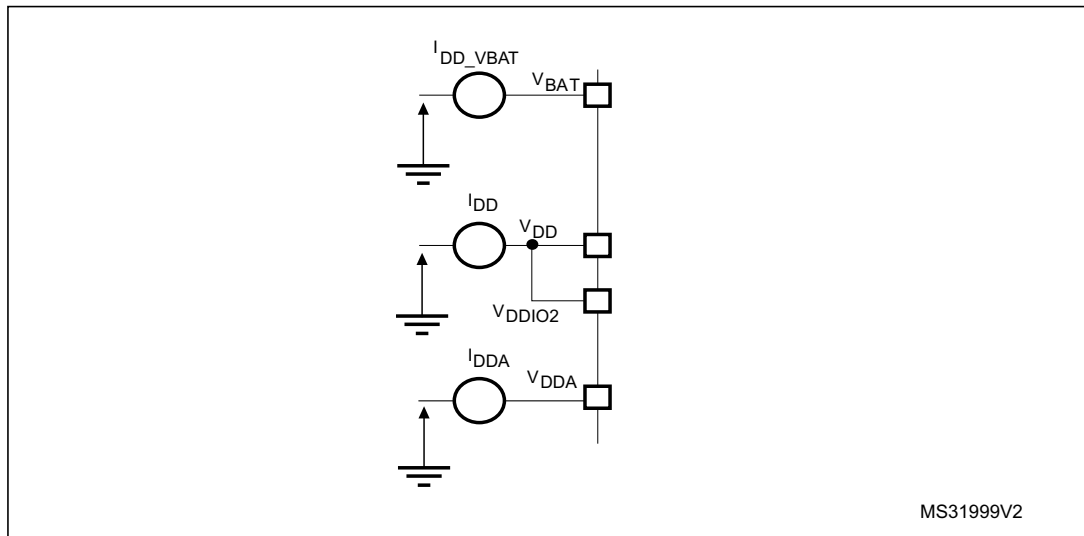

## 6.2 Absolute maximum ratings

Stresses above the absolute maximum ratings listed in [Table 18: Voltage characteristics](#), [Table 19: Current characteristics](#) and [Table 20: Thermal characteristics](#) may cause permanent damage to the device. These are stress ratings only and functional operation of the device at these conditions is not implied. Exposure to maximum rating conditions for extended periods may affect device reliability.

**Table 18. Voltage characteristics<sup>(1)</sup>**

Symbol	Ratings	Min	Max	Unit
$V_{DD}-V_{SS}$	External main supply voltage	-0.3	4.0	V
$V_{DDIO2}-V_{SS}$	External I/O supply voltage	-0.3	4.0	V
$V_{DDA}-V_{SS}$	External analog supply voltage	-0.3	4.0	V
$V_{DD}-V_{DDA}$	Allowed voltage difference for $V_{DD} > V_{DDA}$	-	0.4	V
$V_{BAT}-V_{SS}$	External backup supply voltage	-0.3	4.0	V
$V_{IN}^{(2)}$	Input voltage on FT and FTf pins	$V_{SS} - 0.3$	$V_{DDIOx} + 4.0$	V
	Input voltage on TTa pins	$V_{SS} - 0.3$	4.0	V
	Input voltage on any other pin	$V_{SS} - 0.3$	4.0	V
$ \Delta V_{DDx} $	Variations between different $V_{DD}$ power pins	-	50	mV
$ V_{SSx} - V_{SS} $	Variations between all the different ground pins	-	50	mV
$V_{ESD(HBM)}$	Electrostatic discharge voltage (human body model)	see <a href="#">Section 6.3.12: Electrical sensitivity characteristics</a>		

1. All main power ( $V_{DD}$ ,  $V_{DDA}$ ) and ground ( $V_{SS}$ ,  $V_{SSA}$ ) pins must always be connected to the external power supply, in the permitted range.
2.  $V_{IN}$  maximum must always be respected. Refer to [Table 19: Current characteristics](#) for the maximum allowed injected current values.

**Table 19. Current characteristics**

Symbol	Ratings	Max.	Unit
$\Sigma I_{VDD}$	Total current into sum of all VDD power lines (source) <sup>(1)</sup>	120	mA
$\Sigma I_{VSS}$	Total current out of sum of all VSS ground lines (sink) <sup>(1)</sup>	-120	
$I_{VDD(PIN)}$	Maximum current into each VDD power pin (source) <sup>(1)</sup>	100	
$I_{VSS(PIN)}$	Maximum current out of each VSS ground pin (sink) <sup>(1)</sup>	-100	
$I_{IO(PIN)}$	Output current sunk by any I/O and control pin	25	
	Output current source by any I/O and control pin	-25	
$\Sigma I_{IO(PIN)}$	Total output current sunk by sum of all I/Os and control pins <sup>(2)</sup>	80	
	Total output current sourced by sum of all I/Os and control pins <sup>(2)</sup>	-80	
	Total output current sourced by sum of all I/Os supplied by VDDIO2	-40	
$I_{INJ(PIN)}^{(3)}$	Injected current on FT and FTf pins	-5/+0 <sup>(4)</sup>	
	Injected current on TC and RST pin	± 5	
	Injected current on TTa pins <sup>(5)</sup>	± 5	
$\Sigma I_{INJ(PIN)}$	Total injected current (sum of all I/O and control pins) <sup>(6)</sup>	± 25	

1. All main power (VDD, VDDA) and ground (VSS, VSSA) pins must always be connected to the external power supply, in the permitted range.
2. This current consumption must be correctly distributed over all I/Os and control pins. The total output current must not be sunk/sourced between two consecutive power supply pins referring to high pin count QFP packages.
3. A positive injection is induced by  $V_{IN} > V_{DDIOx}$  while a negative injection is induced by  $V_{IN} < V_{SS}$ .  $I_{INJ(PIN)}$  must never be exceeded. Refer to [Table 18: Voltage characteristics](#) for the maximum allowed input voltage values.
4. Positive injection is not possible on these I/Os and does not occur for input voltages lower than the specified maximum value.
5. On these I/Os, a positive injection is induced by  $V_{IN} > V_{DDA}$ . Negative injection disturbs the analog performance of the device. See note <sup>(2)</sup> below [Table 56: ADC accuracy](#).
6. When several inputs are submitted to a current injection, the maximum  $\Sigma I_{INJ(PIN)}$  is the absolute sum of the positive and negative injected currents (instantaneous values).

**Table 20. Thermal characteristics**

Symbol	Ratings	Value	Unit
$T_{STG}$	Storage temperature range	-65 to +150	°C
$T_J$	Maximum junction temperature	150	°C



## 6.3 Operating conditions

### 6.3.1 General operating conditions

Table 21. General operating conditions

Symbol	Parameter	Conditions	Min	Max	Unit
$f_{HCLK}$	Internal AHB clock frequency		0	48	MHz
$f_{PCLK}$	Internal APB clock frequency		0	48	
$V_{DD}$	Standard operating voltage		2.0	3.6	V
$V_{DDIO2}$	I/O supply voltage	Must not be supplied if $V_{DD}$ is not present	1.65	3.6	V
$V_{DDA}$	Analog operating voltage (ADC not used)	Must have a potential equal to or higher than $V_{DD}$	$V_{DD}$	3.6	V
	Analog operating voltage (ADC used)		2.4	3.6	
$V_{BAT}$	Backup operating voltage		1.65	3.6	V
$V_{IN}$	I/O input voltage	TC and RST I/O	-0.3	$V_{DDIOx}+0.3$	V
		TTa I/O	-0.3	$V_{DDA}+0.3$	
		FT and FTf I/O	-0.3	5.5 <sup>(1)</sup>	
$P_D$	Power dissipation at $T_A = 85\text{ °C}$ for suffix 6 or $T_A = 105\text{ °C}$ for suffix 7 <sup>(2)</sup>	LQFP48	-	364	mW
		UFQFPN48	-	606	
		WLCSP36	-	313	
		LQFP32	-	351	
		UFQFPN32	-	526	
		UFQFPN28	-	170	
		TSSOP20	-	263	
$T_A$	Ambient temperature for the suffix 6 version	Maximum power dissipation	-40	85	°C
		Low power dissipation <sup>(3)</sup>	-40	105	
	Ambient temperature for the suffix 7 version	Maximum power dissipation	-40	105	°C
		Low power dissipation <sup>(3)</sup>	-40	125	
$T_J$	Junction temperature range	Suffix 6 version	-40	105	°C
		Suffix 7 version	-40	125	

1. To sustain a voltage higher than  $V_{DDIOx}+0.3\text{ V}$ , the internal pull-up/pull-down resistors must be disabled.
2. If  $T_A$  is lower, higher  $P_D$  values are allowed as long as  $T_J$  does not exceed  $T_{Jmax}$ . See [Section 7.2: Thermal characteristics](#).
3. In low power dissipation state,  $T_A$  can be extended to this range as long as  $T_J$  does not exceed  $T_{Jmax}$  (see [Section 7.2: Thermal characteristics](#)).

### 6.3.2 Operating conditions at power-up / power-down

The parameters given in [Table 22](#) are derived from tests performed under the ambient temperature condition summarized in [Table 21](#).

**Table 22. Operating conditions at power-up / power-down**

Symbol	Parameter	Conditions	Min	Max	Unit
$t_{VDD}$	$V_{DD}$ rise time rate	-	0	$\infty$	$\mu\text{s/V}$
	$V_{DD}$ fall time rate		20	$\infty$	
$t_{VDDA}$	$V_{DDA}$ rise time rate	-	0	$\infty$	
	$V_{DDA}$ fall time rate		20	$\infty$	

### 6.3.3 Embedded reset and power control block characteristics

The parameters given in [Table 23](#) are derived from tests performed under the ambient temperature and supply voltage conditions summarized in [Table 21: General operating conditions](#).

**Table 23. Embedded reset and power control block characteristics**

Symbol	Parameter	Conditions	Min	Typ	Max	Unit
$V_{POR/PDR}^{(1)}$	Power on/power down reset threshold	Falling edge <sup>(2)</sup>	1.80	1.88	1.96 <sup>(3)</sup>	V
		Rising edge	1.84 <sup>(3)</sup>	1.92	2.00	V
$V_{PDRhyst}$	PDR hysteresis		-	40	-	mV
$t_{RSTTEMPO}^{(4)}$	Reset temporization		1.50	2.50	4.50	ms

1. The PDR detector monitors  $V_{DD}$  and also  $V_{DDA}$  (if kept enabled in the option bytes). The POR detector monitors only  $V_{DD}$ .
2. The product behavior is guaranteed by design down to the minimum  $V_{POR/PDR}$  value.
3. Data based on characterization results, not tested in production.
4. Guaranteed by design, not tested in production.

**Table 24. Programmable voltage detector characteristics**

Symbol	Parameter	Conditions	Min	Typ	Max	Unit
$V_{PVD0}$	PVD threshold 0	Rising edge	2.1	2.18	2.26	V
		Falling edge	2	2.08	2.16	V
$V_{PVD1}$	PVD threshold 1	Rising edge	2.19	2.28	2.37	V
		Falling edge	2.09	2.18	2.27	V
$V_{PVD2}$	PVD threshold 2	Rising edge	2.28	2.38	2.48	V
		Falling edge	2.18	2.28	2.38	V
$V_{PVD3}$	PVD threshold 3	Rising edge	2.38	2.48	2.58	V
		Falling edge	2.28	2.38	2.48	V

Table 24. Programmable voltage detector characteristics (continued)

Symbol	Parameter	Conditions	Min	Typ	Max	Unit
V <sub>PVD4</sub>	PVD threshold 4	Rising edge	2.47	2.58	2.69	V
		Falling edge	2.37	2.48	2.59	V
V <sub>PVD5</sub>	PVD threshold 5	Rising edge	2.57	2.68	2.79	V
		Falling edge	2.47	2.58	2.69	V
V <sub>PVD6</sub>	PVD threshold 6	Rising edge	2.66	2.78	2.9	V
		Falling edge	2.56	2.68	2.8	V
V <sub>PVD7</sub>	PVD threshold 7	Rising edge	2.76	2.88	3	V
		Falling edge	2.66	2.78	2.9	V
V <sub>PVDhyst</sub> <sup>(1)</sup>	PVD hysteresis		-	100	-	mV
I <sub>DD(PVD)</sub>	PVD current consumption		-	0.15	0.26 <sup>(1)</sup>	μA

1. Guaranteed by design, not tested in production.

### 6.3.4 Embedded reference voltage

The parameters given in [Table 25](#) are derived from tests performed under the ambient temperature and supply voltage conditions summarized in [Table 21: General operating conditions](#).

Table 25. Embedded internal reference voltage

Symbol	Parameter	Conditions	Min	Typ	Max	Unit
V <sub>REFINT</sub>	Internal reference voltage	-40 °C < T <sub>A</sub> < +105 °C	1.16	1.2	1.25	V
		-40 °C < T <sub>A</sub> < +85 °C	1.16	1.2	1.24 <sup>(1)</sup>	V
t <sub>S_vrefint</sub>	ADC sampling time when reading the internal reference voltage		4 <sup>(2)</sup>	-	-	μs
ΔV <sub>REFINT</sub>	Internal reference voltage spread over the temperature range	V <sub>DDA</sub> = 3 V	-	-	10 <sup>(2)</sup>	mV
T <sub>Coeff</sub>	Temperature coefficient		- 100 <sup>(2)</sup>	-	100 <sup>(2)</sup>	ppm/°C

1. Data based on characterization results, not tested in production.

2. Guaranteed by design, not tested in production.

### 6.3.5 Supply current characteristics

The current consumption is a function of several parameters and factors such as the operating voltage, ambient temperature, I/O pin loading, device software configuration, operating frequencies, I/O pin switching rate, program location in memory and executed binary code.

The current consumption is measured as described in [Figure 14: Current consumption measurement scheme](#).

All Run-mode current consumption measurements given in this section are performed with a reduced code that gives a consumption equivalent to CoreMark code.

#### Typical and maximum current consumption

The MCU is placed under the following conditions:

- All I/O pins are in analog input mode
- All peripherals are disabled except when explicitly mentioned
- The Flash memory access time is adjusted to the  $f_{HCLK}$  frequency:
  - 0 wait state and Prefetch OFF from 0 to 24 MHz
  - 1 wait state and Prefetch ON above 24 MHz
- When the peripherals are enabled  $f_{PCLK} = f_{HCLK}$

The parameters given in [Table 26](#) to [Table 30](#) are derived from tests performed under ambient temperature and supply voltage conditions summarized in [Table 21: General operating conditions](#).

**Table 26. Typical and maximum current consumption from  $V_{DD}$  supply at  $V_{DD} = 3.6 V$**

Symbol	Parameter	Conditions	$f_{HCLK}$	All peripherals enabled <sup>(1)</sup>				All peripherals disabled				Unit
				Typ	Max @ $T_A$ <sup>(2)</sup>			Typ	Max @ $T_A$ <sup>(2)</sup>			
					25 °C	85 °C	105 °C		25 °C	85 °C	105 °C	
$I_{DD}$	Supply current in Run mode, code executing from Flash	HSI48	48 MHz	20.3	23.2	23.4	24.6	12.7	14.4	14.4	14.7	mA
		HSE bypass, PLL on	48 MHz	20.2	22.9	23.0	23.9	12.6	14.1	14.3	14.4	
			32 MHz	14.0	16.0	16.1	16.7	8.7	9.5	9.7	10.3	
			24 MHz	11.0	13.5	13.7	13.8	6.9	7.6	7.8	8.2	
		HSE bypass, PLL off	8 MHz	3.9	5.2	5.3	5.6	2.6	3.1	3.2	3.3	
			1 MHz	0.9	1.3	1.5	1.8	0.7	1.0	1.1	1.3	
		HSI clock, PLL on	48 MHz	20.5	23.1	23.3	23.6	12.8	14.6	14.6	15.0	
			32 MHz	14.3	15.6	15.9	17.0	8.6	9.5	9.7	10.0	
			24 MHz	11.2	13.6	13.8	14.8	6.9	7.4	7.5	7.7	
		HSI clock, PLL off	8 MHz	4.1	5.2	5.3	5.6	2.6	3.1	3.1	3.3	

Table 26. Typical and maximum current consumption from V<sub>DD</sub> supply at V<sub>DD</sub> = 3.6 V (continued)

Symbol	Parameter	Conditions	f <sub>HCLK</sub>	All peripherals enabled <sup>(1)</sup>				All peripherals disabled				Unit
				Typ	Max @ T <sub>A</sub> <sup>(2)</sup>			Typ	Max @ T <sub>A</sub> <sup>(2)</sup>			
					25 °C	85 °C	105 °C		25 °C	85 °C	105 °C	
I <sub>DD</sub>	Supply current in Run mode, code executing from RAM	HSI48	48 MHz	19.3	21.9	22.1	23.7	11.9	13.4	13.6	13.7	mA
		HSE bypass, PLL on	48 MHz	19.2	21.8 <sup>(3)</sup>	22.0	22.1 <sup>(3)</sup>	11.7	13.3 <sup>(3)</sup>	13.5	13.7 <sup>(3)</sup>	
			32 MHz	13.4	15.8	15.9	16.0	7.9	8.8	8.9	9.7	
			24 MHz	10.3	12.6	13.0	13.4	6.2	8.0	8.2	8.3	
		HSE bypass, PLL off	8 MHz	3.6	4.1	4.3	4.4	2.0	2.1	2.1	2.5	
			1 MHz	0.8	0.9	0.9	1.1	0.4	0.5	0.6	0.8	
		HSI clock, PLL on	48 MHz	19.5	22.0	22.1	22.5	11.8	13.6	13.8	13.9	
			32 MHz	13.5	16.3	16.4	16.6	8.0	8.8	9.1	9.9	
			24 MHz	10.5	12.8	13.0	13.8	6.5	8.0	8.1	8.4	
		HSI clock, PLL off	8 MHz	3.7	4.7	5.0	5.3	2.1	2.3	2.4	3.0	
	Supply current in Sleep mode, code executing from Flash or RAM	HSI48	48 MHz	12.4	15.1	16.3	16.7	3.0	3.2	3.3	3.4	
		HSE bypass, PLL on	48 MHz	12.3	15.0 <sup>(3)</sup>	16.0	16.2 <sup>(3)</sup>	2.9	3.2 <sup>(3)</sup>	3.3	3.4 <sup>(3)</sup>	
			32 MHz	8.5	10.6	11.2	11.7	1.9	2.1	2.2	2.5	
			24 MHz	6.5	8.1	8.5	8.7	1.6	1.8	1.8	1.9	
		HSE bypass, PLL off	8 MHz	2.3	3.0	3.1	3.2	0.7	0.8	0.8	0.9	
			1 MHz	0.4	0.4	0.4	0.6	0.1	0.3	0.3	0.4	
		HSI clock, PLL on	48 MHz	12.4	15.3	15.7	15.9	3.0	3.0	3.2	3.4	
			32 MHz	8.6	10.7	11.3	11.6	2.1	2.2	2.2	2.5	
			24 MHz	6.6	8.4	8.7	8.9	1.6	1.6	1.7	1.9	
		HSI clock, PLL off	8 MHz	2.4	3.2	3.4	3.6	0.6	0.8	0.9	1.0	

1. USB is kept disabled as this IP functions only with a 48 MHz clock.
2. Data based on characterization results, not tested in production unless otherwise specified.
3. Data based on characterization results and tested in production (using one common test limit for sum of I<sub>DD</sub> and I<sub>DDA</sub>).

**Table 27. Typical and maximum current consumption from the V<sub>DDA</sub> supply**

Symbol	Parameter	Conditions <sup>(1)</sup>	f <sub>HCLK</sub>	V <sub>DDA</sub> = 2.4 V			V <sub>DDA</sub> = 3.6 V			Unit		
				Typ	Max @ T <sub>A</sub> <sup>(2)</sup>			Typ	Max @ T <sub>A</sub> <sup>(2)</sup>			
					25 °C	85 °C	105 °C		25 °C		85 °C	105 °C
I <sub>DDA</sub>	Supply current in Run or Sleep mode, code executing from Flash or RAM	HSI48	48 MHz	309	325	332	342	317	334	338	344	μA
		HSE bypass, PLL on	48 MHz	148	167 <sup>(3)</sup>	176	179 <sup>(3)</sup>	161	181 <sup>(3)</sup>	193	197 <sup>(3)</sup>	
			32 MHz	102	119	124	126	111	128	135	137	
			24 MHz	80	95	99	100	88	102	106	108	
		HSE bypass, PLL off	8 MHz	2.7	3.7	4.2	4.5	3.5	4.7	5.2	5.5	
			1 MHz	2.7	3.7	4.2	4.2	3.6	4.7	5.2	5.5	
		HSI clock, PLL on	48 MHz	220	242	251	254	242	264	275	279	
			32 MHz	173	193	200	202	191	211	219	221	
			24 MHz	151	169	175	177	167	184	191	193	
		HSI clock, PLL off	8 MHz	72	82	85	85	82	92	95	95	

1. Current consumption from the V<sub>DDA</sub> supply is independent of whether the digital peripherals are enabled or disabled, being in Run or Sleep mode or executing from Flash or RAM. Furthermore, when the PLL is off, I<sub>DDA</sub> is independent from the frequency.
2. Data based on characterization results, not tested in production unless otherwise specified.
3. Data based on characterization results and tested in production (using one common test limit for sum of I<sub>DD</sub> and I<sub>DDA</sub>).

Table 28. Typical and maximum consumption in Stop and Standby modes

Symbol	Parameter	Conditions	Typ @V <sub>DD</sub> (V <sub>DD</sub> = V <sub>DDA</sub> )						Max <sup>(1)</sup>			Unit		
			= 2.0 V	= 2.4 V	= 2.7 V	= 3.0 V	= 3.3 V	= 3.6 V	T <sub>A</sub> = 25°C	T <sub>A</sub> = 85°C	T <sub>A</sub> = 105°C			
I <sub>DD</sub>	Supply current in Stop mode	Regulator in stop mode, all oscillators OFF	14.3	14.5	14.6	14.7	14.8	14.9	21.0	47.0	64.0	μA		
		Regulator in low-power mode, all oscillators OFF	2.9	3.1	3.2	3.3	3.4	3.5	6.5	32.0	44.0			
	Supply current in Standby mode	LSI ON and IWDG ON	0.8	0.9	1.1	1.2	1.3	1.5	-	-	-			
		LSI OFF and IWDG OFF	0.6	0.7	0.8	0.9	1.0	1.1	2.0	2.5	3.0			
I <sub>DDA</sub>	Supply current in Stop mode	V <sub>DDA</sub> monitoring ON	Regulator in stop mode, all oscillators OFF	2.0	2.1	2.2	2.4	2.5	2.7	3.5	3.5		4.5	
			Regulator in low-power mode, all oscillators OFF	2.0	2.1	2.2	2.4	2.5	2.7	3.5	3.5		4.5	
	Supply current in Standby mode	V <sub>DDA</sub> monitoring ON	LSI ON and IWDG ON	2.4	2.6	2.8	3.0	3.1	3.4	-	-		-	
			LSI OFF and IWDG OFF	1.9	2.0	2.1	2.3	2.4	2.5	3.4	3.5		4.5	
	Supply current in Stop mode	V <sub>DDA</sub> monitoring OFF	Regulator in stop mode, all oscillators OFF	1.3	1.3	1.3	1.4	1.4	1.5	-	-		-	
			Regulator in low-power mode, all oscillators OFF	1.3	1.3	1.3	1.4	1.4	1.5	-	-		-	
		Supply current in Standby mode	V <sub>DDA</sub> monitoring OFF	LSI ON and IWDG ON	1.7	1.8	1.8	2.0	2.1	2.2	-		-	-
				LSI OFF and IWDG OFF	1.1	1.2	1.2	1.3	1.3	1.4	-		-	-

1. Data based on characterization results, not tested in production unless otherwise specified.

**Table 29. Typical and maximum current consumption from the V<sub>BAT</sub> supply**

Symbol	Parameter	Conditions	Typ @ V <sub>BAT</sub>						Max <sup>(1)</sup>			Unit
			= 1.65 V	= 1.8 V	= 2.4 V	= 2.7 V	= 3.3 V	= 3.6 V	T <sub>A</sub> = 25 °C	T <sub>A</sub> = 85 °C	T <sub>A</sub> = 105 °C	
I <sub>DD-VBAT</sub>	RTC domain supply current	LSE & RTC ON; “Xtal mode”: lower driving capability; LSEDRV[1:0] = '00'	0.5	0.5	0.6	0.7	0.9	1.1	1.2	1.5	2.0	µA
		LSE & RTC ON; “Xtal mode” higher driving capability; LSEDRV[1:0] = '11'	0.8	0.9	1.1	1.2	1.4	1.5	1.6	2.0	2.6	

1. Data based on characterization results, not tested in production.

**Typical current consumption**

The MCU is placed under the following conditions:

- V<sub>DD</sub> = V<sub>DDA</sub> = 3.3 V
- All I/O pins are in analog input configuration
- The Flash access time is adjusted to f<sub>HCLK</sub> frequency:
  - 0 wait state and Prefetch OFF from 0 to 24 MHz
  - 1 wait state and Prefetch ON above 24 MHz
- When the peripherals are enabled, f<sub>PCLK</sub> = f<sub>HCLK</sub>
- PLL is used for frequencies greater than 8 MHz
- AHB prescaler of 2, 4, 8 and 16 is used for the frequencies 4 MHz, 2 MHz, 1 MHz and 500 kHz respectively



**Table 30. Typical current consumption, code executing from Flash, running from HSE  
8 MHz crystal**

Symbol	Parameter	f <sub>HCLK</sub>	Typical consumption in Run mode		Typical consumption in Sleep mode		Unit
			Peripherals enabled	Peripherals disabled	Peripherals enabled	Peripherals disabled	
I <sub>DD</sub>	Current consumption from V <sub>DD</sub> supply	48 MHz	20.7	12.8	12.3	3.4	mA
		36 MHz	15.9	9.9	9.5	2.7	
		32 MHz	14.3	9.0	8.5	2.5	
		24 MHz	11.0	7.1	6.6	2.1	
		16 MHz	7.7	5.0	4.7	1.6	
		8 MHz	4.3	3.0	2.7	1.2	
		4 MHz	2.6	2.0	1.7	0.9	
		2 MHz	1.8	1.5	1.2	0.8	
		1 MHz	1.4	1.2	1.0	0.8	
		500 kHz	1.2	1.1	0.8	0.7	
I <sub>DDA</sub>	Current consumption from V <sub>DDA</sub> supply	48 MHz	163.3				μA
		36 MHz	124.3				
		32 MHz	111.9				
		24 MHz	87.1				
		16 MHz	62.5				
		8 MHz	2.5				
		4 MHz	2.5				
		2 MHz	2.5				
		1 MHz	2.5				
		500 kHz	2.5				

### I/O system current consumption

The current consumption of the I/O system has two components: static and dynamic.

#### I/O static current consumption

All the I/Os used as inputs with pull-up generate current consumption when the pin is externally held low. The value of this current consumption can be simply computed by using the pull-up/pull-down resistors values given in [Table 50: I/O static characteristics](#).

For the output pins, any external pull-down or external load must also be considered to estimate the current consumption.

Additional I/O current consumption is due to I/Os configured as inputs if an intermediate voltage level is externally applied. This current consumption is caused by the input Schmitt trigger circuits used to discriminate the input value. Unless this specific configuration is required by the application, this supply current consumption can be avoided by configuring these I/Os in analog mode. This is notably the case of ADC input pins which should be configured as analog inputs.

**Caution:** Any floating input pin can also settle to an intermediate voltage level or switch inadvertently, as a result of external electromagnetic noise. To avoid current consumption related to floating pins, they must either be configured in analog mode, or forced internally to a definite digital value. This can be done either by using pull-up/down resistors or by configuring the pins in output mode.

#### I/O dynamic current consumption

In addition to the internal peripheral current consumption measured previously (see [Table 32: Peripheral current consumption](#)), the I/Os used by an application also contribute to the current consumption. When an I/O pin switches, it uses the current from the I/O supply voltage to supply the I/O pin circuitry and to charge/discharge the capacitive load (internal or external) connected to the pin:

$$I_{SW} = V_{DDIOx} \times f_{SW} \times C$$

where

$I_{SW}$  is the current sunk by a switching I/O to charge/discharge the capacitive load

$V_{DDIOx}$  is the I/O supply voltage

$f_{SW}$  is the I/O switching frequency

$C$  is the total capacitance seen by the I/O pin:  $C = C_{INT} + C_{EXT} + C_S$

$C_S$  is the PCB board capacitance including the pad pin.

The test pin is configured in push-pull output mode and is toggled by software at a fixed frequency.

Table 31. Switching output I/O current consumption

Symbol	Parameter	Conditions <sup>(1)</sup>	I/O toggling frequency (f <sub>SW</sub> )	Typ	Unit
I <sub>sw</sub>	I/O current consumption	V <sub>DDIOx</sub> = 3.3 V C = C <sub>INT</sub>	4 MHz	0.07	mA
			8 MHz	0.15	
			16 MHz	0.31	
			24 MHz	0.53	
			48 MHz	0.92	
		V <sub>DDIOx</sub> = 3.3 V C <sub>EXT</sub> = 0 pF C = C <sub>INT</sub> + C <sub>EXT</sub> + C <sub>S</sub>	4 MHz	0.18	
			8 MHz	0.37	
			16 MHz	0.76	
			24 MHz	1.39	
			48 MHz	2.188	
		V <sub>DDIOx</sub> = 3.3 V C <sub>EXT</sub> = 10 pF C = C <sub>INT</sub> + C <sub>EXT</sub> + C <sub>S</sub>	4 MHz	0.32	
			8 MHz	0.64	
			16 MHz	1.25	
			24 MHz	2.23	
			48 MHz	4.442	
		V <sub>DDIOx</sub> = 3.3 V C <sub>EXT</sub> = 22 pF C = C <sub>INT</sub> + C <sub>EXT</sub> + C <sub>S</sub>	4 MHz	0.49	
			8 MHz	0.94	
			16 MHz	2.38	
			24 MHz	3.99	
			V <sub>DDIOx</sub> = 3.3 V C <sub>EXT</sub> = 33 pF C = C <sub>INT</sub> + C <sub>EXT</sub> + C <sub>S</sub>	4 MHz	
		8 MHz		1.25	
		16 MHz		3.24	
		24 MHz		5.02	
		V <sub>DDIOx</sub> = 3.3 V C <sub>EXT</sub> = 47 pF C = C <sub>INT</sub> + C <sub>EXT</sub> + C <sub>S</sub> C = C <sub>int</sub>		4 MHz	
8 MHz	1.7				
16 MHz	3.67				
V <sub>DDIOx</sub> = 2.4 V C <sub>EXT</sub> = 47 pF C = C <sub>INT</sub> + C <sub>EXT</sub> + C <sub>S</sub> C = C <sub>int</sub>	4 MHz		0.66		
	8 MHz	1.43			
	16 MHz	2.45			
	24 MHz	4.97			

1. C<sub>S</sub> = 7 pF (estimated value).

**On-chip peripheral current consumption**

The current consumption of the on-chip peripherals is given in [Table 32](#). The MCU is placed under the following conditions:

- All I/O pins are in analog mode
- All peripherals are disabled unless otherwise mentioned
- The given value is calculated by measuring the current consumption
  - with all peripherals clocked off
  - with only one peripheral clocked on
- Ambient operating temperature and supply voltage conditions summarized in [Table 18: Voltage characteristics](#)

**Table 32. Peripheral current consumption**

Peripheral		Typical consumption at 25 °C	Unit
AHB	BusMatrix <sup>(1)</sup>	2.2	μA/MHz
	CRC	1.9	
	DMA	5.1	
	Flash interface	15.0	
	GPIOA	8.2	
	GPIOB	7.7	
	GPIOC	2.1	
	GPIOF	1.8	
	SRAM	1.1	
	TSC	4.9	
	ALL AHB Peripherals	50.7	

**Table 32. Peripheral current consumption (continued)**

Peripheral		Typical consumption at 25 °C	Unit
APB	APB-Bridge <sup>(2)</sup>	2.1	μA/MHz
	ADC <sup>(3)</sup>	4.7	
	CAN	13.8	
	CEC	2.4	
	CRS	1.8	
	DEBUG (MCU debug feature)	1.1	
	I2C1	4.5	
	PWR	2.3	
	SPI1	9.4	
	SPI2	6.5	
	SYSCFG	2.7	
	TIM1	16.0	
	TIM2	17.6	
	TIM3	12.5	
	TIM14	6.4	
	TIM16	7.9	
	TIM17	7.8	
	USART1	18.6	
	USART2	6.5	
	USB	6.6	
WWDG	2.2		
ALL APB Peripherals	153.8		

1. The BusMatrix is automatically active when at least one master is ON (CPU, DMA).
2. The APB Bridge is automatically active when at least one peripheral is ON on the Bus.
3. The power consumption of the analog part (I<sub>DDA</sub>) of peripherals such as ADC is not included. Refer to the tables of characteristics in the subsequent sections.

### 6.3.6 Wakeup time from low-power mode

The wakeup times given in [Table 33](#) are the latency between the event and the execution of the first user instruction. The device goes in low-power mode after the WFE (Wait For Event) instruction, in the case of a WFI (Wait For Interruption) instruction, 16 CPU cycles must be added to the following timings due to the interrupt latency in the Cortex M0 architecture.

The SYSCLK clock source setting is kept unchanged after wakeup from Sleep mode. During wakeup from Stop or Standby mode, SYSCLK takes the default setting: HSI 8 MHz.

The wakeup source from Sleep and Stop mode is an EXTI line configured in event mode. The wakeup source from Standby mode is the WKUP1 pin (PA0).

All timings are derived from tests performed under the ambient temperature and supply voltage conditions summarized in [Table 21: General operating conditions](#).

**Table 33. Low-power mode wakeup timings**

Symbol	Parameter	Conditions	Typ @VDD = VDDA					Max	Unit
			= 2.0 V	= 2.4 V	= 2.7 V	= 3 V	= 3.3 V		
t <sub>WU</sub> STOP	Wakeup from Stop mode	Regulator in run mode	3.2	3.1	2.9	2.9	2.8	5	μs
		Regulator in low power mode	7.0	5.8	5.2	4.9	4.6	9	
t <sub>WU</sub> STANDBY	Wakeup from Standby mode		60.4	55.6	53.5	52	51	-	
t <sub>WU</sub> SLEEP	Wakeup from Sleep mode		4 SYSCLK cycles					-	

### 6.3.7 External clock source characteristics

#### High-speed external user clock generated from an external source

In bypass mode the HSE oscillator is switched off and the input pin is a standard GPIO.

The external clock signal has to respect the I/O characteristics in [Section 6.3.14](#). However, the recommended clock input waveform is shown in [Figure 15: High-speed external clock source AC timing diagram](#).

**Table 34. High-speed external user clock characteristics**

Symbol	Parameter <sup>(1)</sup>	Conditions	Min	Typ	Max	Unit
$f_{HSE\_ext}$	User external clock source frequency	-	-	8	32	MHz
$V_{HSEH}$	OSC_IN input pin high level voltage	-	$0.7 V_{DDIOx}$	-	$V_{DDIOx}$	V
$V_{HSEL}$	OSC_IN input pin low level voltage	-	$V_{SS}$	-	$0.3 V_{DDIOx}$	
$t_{w(HSEH)}$ $t_{w(HSEL)}$	OSC_IN high or low time	-	15	-	-	ns
$t_{r(HSE)}$ $t_{f(HSE)}$	OSC_IN rise or fall time	-	-	-	20	

1. Guaranteed by design, not tested in production.

**Figure 15. High-speed external clock source AC timing diagram**

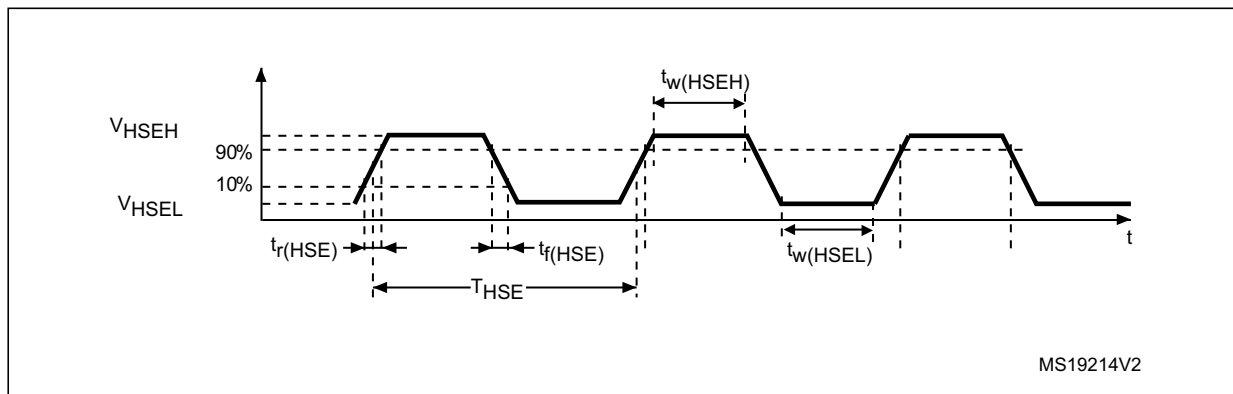

**Low-speed external user clock generated from an external source**

In bypass mode the LSE oscillator is switched off and the input pin is a standard GPIO.

The external clock signal has to respect the I/O characteristics in [Section 6.3.14](#). However, the recommended clock input waveform is shown in [Figure 16](#).

**Table 35. Low-speed external user clock characteristics**

Symbol	Parameter <sup>(1)</sup>	Conditions	Min	Typ	Max	Unit
$f_{LSE\_ext}$	User external clock source frequency		-	32.768	1000	kHz
$V_{LSEH}$	OSC32_IN input pin high level voltage		$0.7 V_{DDIOx}$	-	$V_{DDIOx}$	V
$V_{LSEL}$	OSC32_IN input pin low level voltage		$V_{SS}$	-	$0.3 V_{DDIOx}$	
$t_{w(LSEH)}$ $t_{w(LSEL)}$	OSC32_IN high or low time		450	-	-	ns
$t_{r(LSE)}$ $t_{f(LSE)}$	OSC32_IN rise or fall time		-	-	50	

1. Guaranteed by design, not tested in production.

**Figure 16. Low-speed external clock source AC timing diagram**

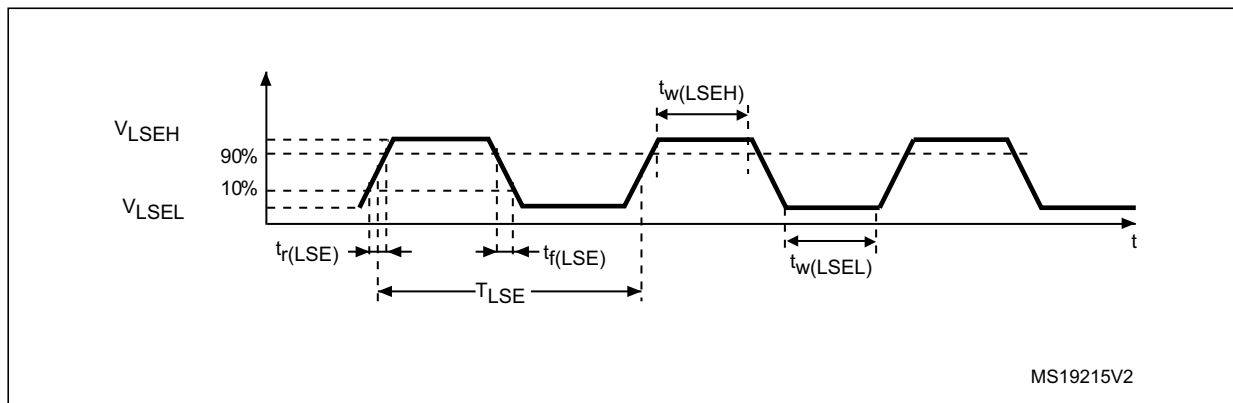



### High-speed external clock generated from a crystal/ceramic resonator

The high-speed external (HSE) clock can be supplied with a 4 to 32 MHz crystal/ceramic resonator oscillator. All the information given in this paragraph are based on design simulation results obtained with typical external components specified in [Table 36](#). In the application, the resonator and the load capacitors have to be placed as close as possible to the oscillator pins in order to minimize output distortion and startup stabilization time. Refer to the crystal resonator manufacturer for more details on the resonator characteristics (frequency, package, accuracy).

**Table 36. HSE oscillator characteristics**

Symbol	Parameter	Conditions <sup>(1)</sup>	Min <sup>(2)</sup>	Typ	Max <sup>(2)</sup>	Unit
f <sub>OSC_IN</sub>	Oscillator frequency		4	8	32	MHz
R <sub>F</sub>	Feedback resistor		-	200	-	kΩ
I <sub>DD</sub>	HSE current consumption	During startup <sup>(3)</sup>	-		8.5	mA
		V <sub>DD</sub> = 3.3 V, R <sub>m</sub> = 30 Ω, CL = 10 pF@8 MHz	-	0.4	-	
		V <sub>DD</sub> = 3.3 V, R <sub>m</sub> = 45 Ω, CL = 10 pF@8 MHz	-	0.5	-	
		V <sub>DD</sub> = 3.3 V, R <sub>m</sub> = 30 Ω, CL = 5 pF@32 MHz	-	0.8	-	
		V <sub>DD</sub> = 3.3 V, R <sub>m</sub> = 30 Ω, CL = 10 pF@32 MHz	-	1	-	
		V <sub>DD</sub> = 3.3 V, R <sub>m</sub> = 30 Ω, CL = 20 pF@32 MHz	-	1.5	-	
g <sub>m</sub>	Oscillator transconductance	Startup	10	-	-	mA/V
t <sub>SU(HSE)</sub> <sup>(4)</sup>	Startup time	V <sub>DD</sub> is stabilized	-	2	-	ms

1. Resonator characteristics given by the crystal/ceramic resonator manufacturer.
2. Guaranteed by design, not tested in production.
3. This consumption level occurs during the first 2/3 of the t<sub>SU(HSE)</sub> startup time
4. t<sub>SU(HSE)</sub> is the startup time measured from the moment it is enabled (by software) to a stabilized 8 MHz oscillation is reached. This value is measured for a standard crystal resonator and it can vary significantly with the crystal manufacturer

For C<sub>L1</sub> and C<sub>L2</sub>, it is recommended to use high-quality external ceramic capacitors in the 5 pF to 20 pF range (typ.), designed for high-frequency applications, and selected to match the requirements of the crystal or resonator (see [Figure 17](#)). C<sub>L1</sub> and C<sub>L2</sub> are usually the same size. The crystal manufacturer typically specifies a load capacitance which is the series combination of C<sub>L1</sub> and C<sub>L2</sub>. PCB and MCU pin capacitance must be included (10 pF can be used as a rough estimate of the combined pin and board capacitance) when sizing C<sub>L1</sub> and C<sub>L2</sub>.

**Note:** For information on selecting the crystal, refer to the application note AN2867 "Oscillator design guide for ST microcontrollers" available from the ST website [www.st.com](http://www.st.com).

Figure 17. Typical application with an 8 MHz crystal

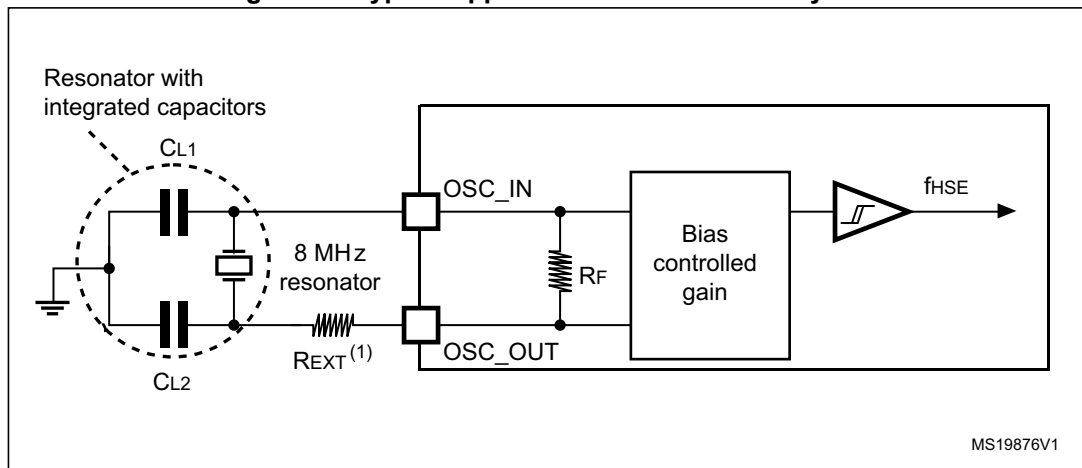

1.  $R_{EXT}$  value depends on the crystal characteristics.

### Low-speed external clock generated from a crystal resonator

The low-speed external (LSE) clock can be supplied with a 32.768 kHz crystal resonator oscillator. All the information given in this paragraph are based on design simulation results obtained with typical external components specified in [Table 37](#). In the application, the resonator and the load capacitors have to be placed as close as possible to the oscillator pins in order to minimize output distortion and startup stabilization time. Refer to the crystal resonator manufacturer for more details on the resonator characteristics (frequency, package, accuracy).

**Table 37. LSE oscillator characteristics ( $f_{LSE} = 32.768$  kHz)**

Symbol	Parameter	Conditions <sup>(1)</sup>	Min <sup>(2)</sup>	Typ	Max <sup>(2)</sup>	Unit
$I_{DD}$	LSE current consumption	LSEDRV[1:0]=00 lower driving capability	-	0.5	0.9	$\mu$ A
		LSEDRV[1:0]= 01 medium low driving capability	-	-	1	
		LSEDRV[1:0] = 10 medium high driving capability	-	-	1.3	
		LSEDRV[1:0]=11 higher driving capability	-	-	1.6	
$g_m$	Oscillator transconductance	LSEDRV[1:0]=00 lower driving capability	5	-	-	$\mu$ A/V
		LSEDRV[1:0]= 01 medium low driving capability	8	-	-	
		LSEDRV[1:0] = 10 medium high driving capability	15	-	-	
		LSEDRV[1:0]=11 higher driving capability	25	-	-	
$t_{SU(LSE)}$ <sup>(3)</sup>	Startup time	$V_{DDIOX}$ is stabilized	-	2	-	s

1. Refer to the note and caution paragraphs below the table, and to the application note AN2867 "Oscillator design guide for ST microcontrollers".
2. Guaranteed by design, not tested in production.
3.  $t_{SU(LSE)}$  is the startup time measured from the moment it is enabled (by software) to a stabilized 32.768 kHz oscillation is reached. This value is measured for a standard crystal and it can vary significantly with the crystal manufacturer

**Note:** For information on selecting the crystal, refer to the application note AN2867 "Oscillator design guide for ST microcontrollers" available from the ST website [www.st.com](http://www.st.com).

Figure 18. Typical application with a 32.768 kHz crystal

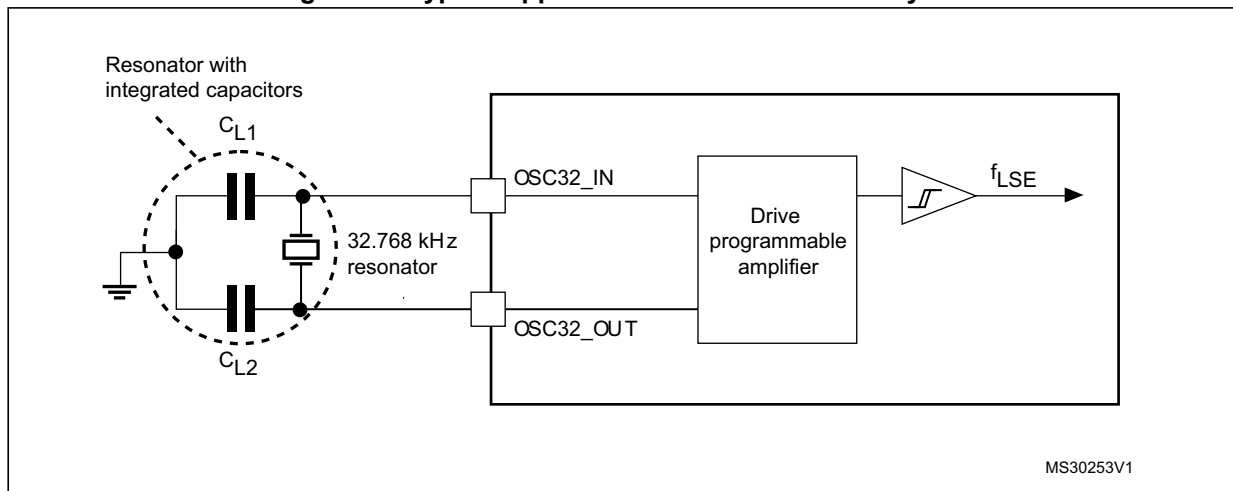

**Note:** An external resistor is not required between OSC32\_IN and OSC32\_OUT and it is forbidden to add one.

### 6.3.8 Internal clock source characteristics

The parameters given in *Table 38* are derived from tests performed under ambient temperature and supply voltage conditions summarized in *Table 21: General operating conditions*. The provided curves are characterization results, not tested in production.

#### High-speed internal (HSI) RC oscillator

**Table 38. HSI oscillator characteristics<sup>(1)</sup>**

Symbol	Parameter	Conditions	Min	Typ	Max	Unit
$f_{HSI}$	Frequency		-	8	-	MHz
TRIM	HSI user trimming step		-	-	1 <sup>(2)</sup>	%
DuCy <sub>(HSI)</sub>	Duty cycle		45 <sup>(2)</sup>	-	55 <sup>(2)</sup>	%
ACC <sub>HSI</sub>	Accuracy of the HSI oscillator (factory calibrated)	T <sub>A</sub> = -40 to 105 °C	-3.8 <sup>(3)</sup>	-	4.6 <sup>(3)</sup>	%
		T <sub>A</sub> = -10 to 85 °C	-2.9 <sup>(3)</sup>	-	2.9 <sup>(3)</sup>	%
		T <sub>A</sub> = 0 to 70 °C	-2.3 <sup>(3)</sup>	-	2.2 <sup>(3)</sup>	%
		T <sub>A</sub> = 25 °C	-1	-	1	%
t <sub>su(HSI)</sub>	HSI oscillator startup time		1 <sup>(2)</sup>	-	2 <sup>(2)</sup>	µs
I <sub>DDA(HSI)</sub>	HSI oscillator power consumption		-	80	100 <sup>(2)</sup>	µA

1. V<sub>DDA</sub> = 3.3 V, T<sub>A</sub> = -40 to 105 °C unless otherwise specified.
2. Guaranteed by design, not tested in production.
3. Data based on characterization results, not tested in production.

**Figure 19. HSI oscillator accuracy characterization results**

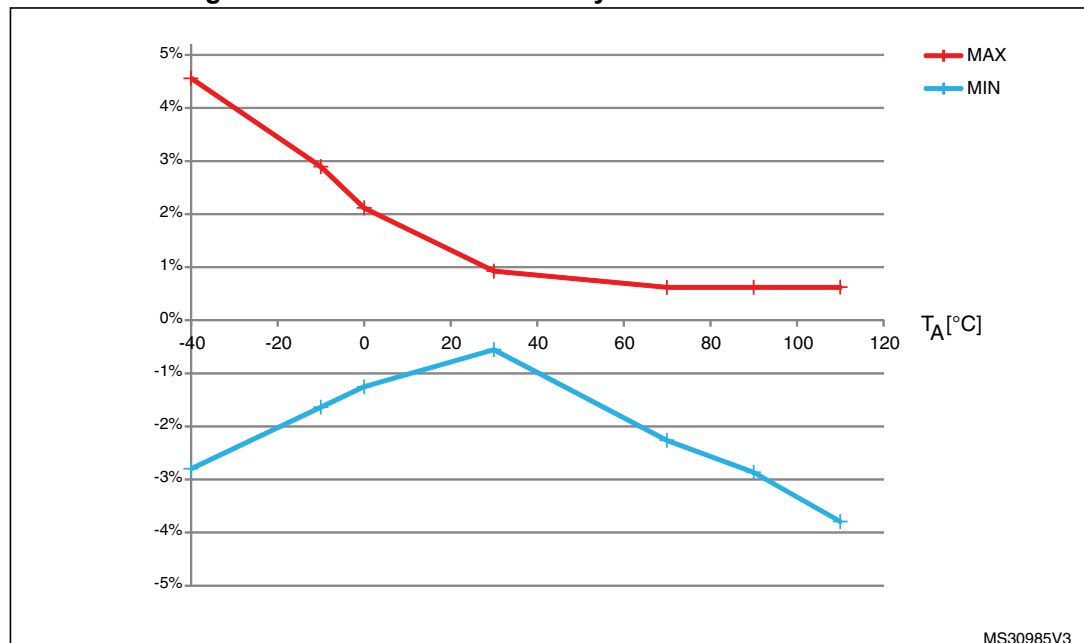

High-speed internal 14 MHz (HSI14) RC oscillator (dedicated to ADC)

Table 39. HSI14 oscillator characteristics<sup>(1)</sup>

Symbol	Parameter	Conditions	Min	Typ	Max	Unit
$f_{\text{HSI14}}$	Frequency		-	14	-	MHz
TRIM	HSI14 user-trimming step		-	-	1 <sup>(2)</sup>	%
$\text{DuCy}_{\text{(HSI14)}}$	Duty cycle		45 <sup>(2)</sup>	-	55 <sup>(2)</sup>	%
$\text{ACC}_{\text{HSI14}}$	Accuracy of the HSI14 oscillator (factory calibrated)	$T_A = -40 \text{ to } 105 \text{ }^\circ\text{C}$	-4.2 <sup>(3)</sup>	-	5.1 <sup>(3)</sup>	%
		$T_A = -10 \text{ to } 85 \text{ }^\circ\text{C}$	-3.2 <sup>(3)</sup>	-	3.1 <sup>(3)</sup>	%
		$T_A = 0 \text{ to } 70 \text{ }^\circ\text{C}$	-2.5 <sup>(3)</sup>	-	2.3 <sup>(3)</sup>	%
		$T_A = 25 \text{ }^\circ\text{C}$	-1	-	1	%
$t_{\text{su(HSI14)}}$	HSI14 oscillator startup time		1 <sup>(2)</sup>	-	2 <sup>(2)</sup>	$\mu\text{s}$
$I_{\text{DDA(HSI14)}}$	HSI14 oscillator power consumption		-	100	150 <sup>(2)</sup>	$\mu\text{A}$

1.  $V_{\text{DDA}} = 3.3 \text{ V}$ ,  $T_A = -40 \text{ to } 105 \text{ }^\circ\text{C}$  unless otherwise specified.
2. Guaranteed by design, not tested in production.
3. Data based on characterization results, not tested in production.

Figure 20. HSI14 oscillator accuracy characterization results

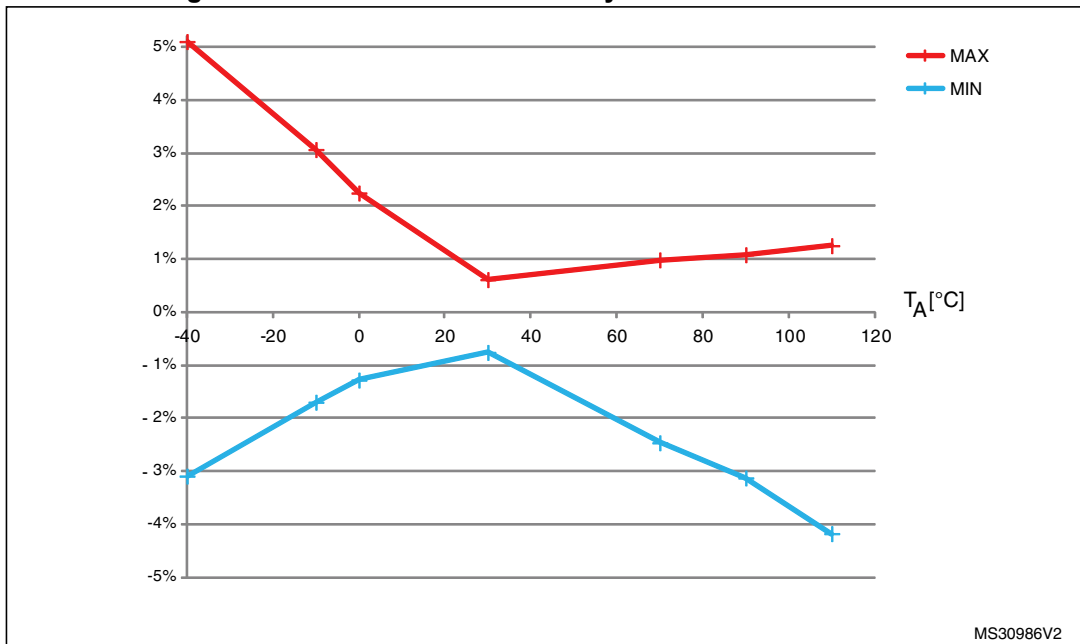

MS30986V2

High-speed internal 48 MHz (HSI48) RC oscillator

Table 40. HSI48 oscillator characteristics<sup>(1)</sup>

Symbol	Parameter	Conditions	Min	Typ	Max	Unit
$f_{\text{HSI48}}$	Frequency		-	48	-	MHz
TRIM	HSI48 user-trimming step		0.09 <sup>(2)</sup>	0.14	0.2 <sup>(2)</sup>	%
DuCy <sub>(HSI48)</sub>	Duty cycle		45 <sup>(2)</sup>	-	55 <sup>(2)</sup>	%
$\text{ACC}_{\text{HSI48}}$	Accuracy of the HSI48 oscillator (factory calibrated)	$T_A = -40$ to $105$ °C	-4.9 <sup>(3)</sup>	-	4.7 <sup>(3)</sup>	%
		$T_A = -10$ to $85$ °C	-4.1 <sup>(3)</sup>	-	3.7 <sup>(3)</sup>	%
		$T_A = 0$ to $70$ °C	-3.8 <sup>(3)</sup>	-	3.4 <sup>(3)</sup>	%
		$T_A = 25$ °C	-2.8	-	2.9	%
$t_{\text{su(HSI48)}}$	HSI48 oscillator startup time		-	-	6 <sup>(2)</sup>	µs
$I_{\text{DDA(HSI48)}}$	HSI48 oscillator power consumption		-	312	350 <sup>(2)</sup>	µA

- $V_{\text{DDA}} = 3.3$  V,  $T_A = -40$  to  $105$  °C unless otherwise specified.
- Guaranteed by design, not tested in production.
- Data based on characterization results, not tested in production.

Figure 21. HSI48 oscillator accuracy characterization results

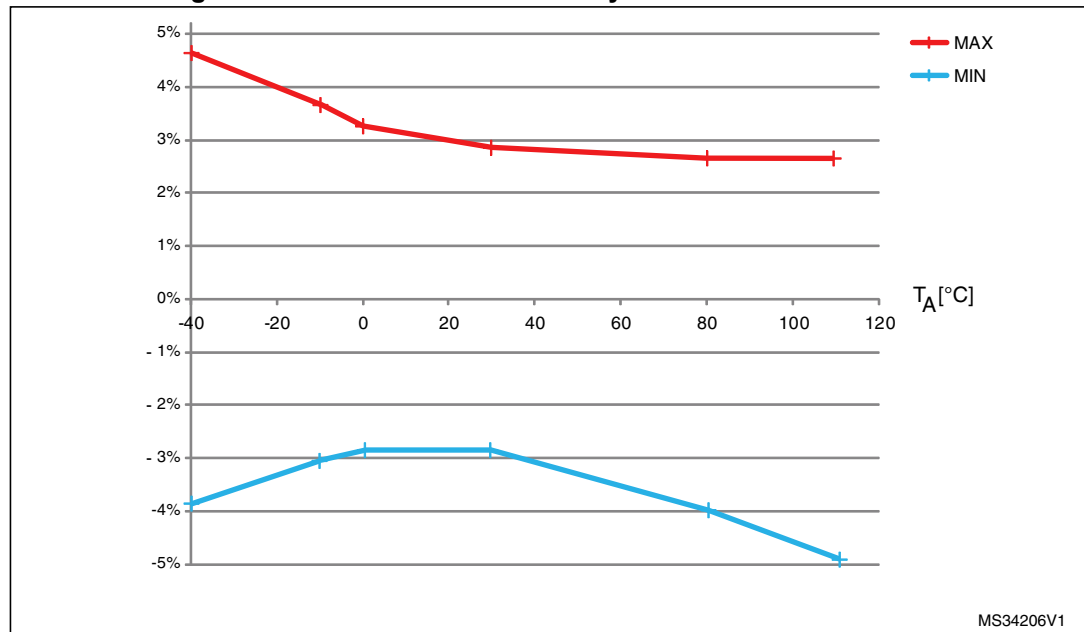

### Low-speed internal (LSI) RC oscillator

**Table 41. LSI oscillator characteristics<sup>(1)</sup>**

Symbol	Parameter	Min	Typ	Max	Unit
$f_{LSI}$	Frequency	30	40	50	kHz
$t_{su(LSI)}^{(2)}$	LSI oscillator startup time	-	-	85	$\mu$ s
$I_{DDA(LSI)}^{(2)}$	LSI oscillator power consumption	-	0.75	1.2	$\mu$ A

1.  $V_{DDA} = 3.3$  V,  $T_A = -40$  to  $105$  °C unless otherwise specified.

2. Guaranteed by design, not tested in production.

### 6.3.9 PLL characteristics

The parameters given in [Table 42](#) are derived from tests performed under ambient temperature and supply voltage conditions summarized in [Table 21: General operating conditions](#).

**Table 42. PLL characteristics**

Symbol	Parameter	Value			Unit
		Min	Typ	Max	
$f_{PLL\_IN}$	PLL input clock <sup>(1)</sup>	1 <sup>(2)</sup>	8.0	24 <sup>(2)</sup>	MHz
	PLL input clock duty cycle	40 <sup>(2)</sup>	-	60 <sup>(2)</sup>	%
$f_{PLL\_OUT}$	PLL multiplier output clock	16 <sup>(2)</sup>	-	48	MHz
$t_{LOCK}$	PLL lock time	-	-	200 <sup>(2)</sup>	$\mu$ s
$Jitter_{PLL}$	Cycle-to-cycle jitter	-	-	300 <sup>(2)</sup>	ps

1. Take care to use the appropriate multiplier factors to obtain PLL input clock values compatible with the range defined by  $f_{PLL\_OUT}$ .

2. Guaranteed by design, not tested in production.



### 6.3.10 Memory characteristics

#### Flash memory

The characteristics are given at  $T_A = -40$  to  $105$  °C unless otherwise specified.

**Table 43. Flash memory characteristics**

Symbol	Parameter	Conditions	Min	Typ	Max <sup>(1)</sup>	Unit
$t_{\text{prog}}$	16-bit programming time	$T_A = -40$ to $+105$ °C	40	53.5	60	µs
$t_{\text{ERASE}}$	Page (1 KB) erase time	$T_A = -40$ to $+105$ °C	20	-	40	ms
$t_{\text{ME}}$	Mass erase time	$T_A = -40$ to $+105$ °C	20	-	40	ms
$I_{\text{DD}}$	Supply current	Write mode	-	-	10	mA
		Erase mode	-	-	12	mA

1. Guaranteed by design, not tested in production.

**Table 44. Flash memory endurance and data retention**

Symbol	Parameter	Conditions	Min <sup>(1)</sup>	Unit
$N_{\text{END}}$	Endurance	$T_A = -40$ to $+105$ °C	10	kcycles
$t_{\text{RET}}$	Data retention	1 kcycle <sup>(2)</sup> at $T_A = 85$ °C	30	Years
		1 kcycle <sup>(2)</sup> at $T_A = 105$ °C	10	
		10 kcycles <sup>(2)</sup> at $T_A = 55$ °C	20	

1. Data based on characterization results, not tested in production.

2. Cycling performed over the whole temperature range.

### 6.3.11 EMC characteristics

Susceptibility tests are performed on a sample basis during device characterization.

#### Functional EMS (electromagnetic susceptibility)

While a simple application is executed on the device (toggling 2 LEDs through I/O ports), the device is stressed by two electromagnetic events until a failure occurs. The failure is indicated by the LEDs:

- **Electrostatic discharge (ESD)** (positive and negative) is applied to all device pins until a functional disturbance occurs. This test is compliant with the IEC 61000-4-2 standard.
- **FTB:** A Burst of Fast Transient voltage (positive and negative) is applied to  $V_{\text{DD}}$  and  $V_{\text{SS}}$  through a 100 pF capacitor, until a functional disturbance occurs. This test is compliant with the IEC 61000-4-4 standard.

A device reset allows normal operations to be resumed.

The test results are given in [Table 45](#). They are based on the EMS levels and classes defined in application note AN1709.

**Table 45. EMS characteristics**

Symbol	Parameter	Conditions	Level/Class
V <sub>FESD</sub>	Voltage limits to be applied on any I/O pin to induce a functional disturbance	V <sub>DD</sub> = 3.3 V, LQFP48, T <sub>A</sub> = +25 °C, f <sub>HCLK</sub> = 48 MHz, conforming to IEC 61000-4-2	3B
V <sub>EFTB</sub>	Fast transient voltage burst limits to be applied through 100 pF on V <sub>DD</sub> and V <sub>SS</sub> pins to induce a functional disturbance	V <sub>DD</sub> = 3.3 V, LQFP48, T <sub>A</sub> = +25°C, f <sub>HCLK</sub> = 48 MHz, conforming to IEC 61000-4-4	4B

**Designing hardened software to avoid noise problems**

EMC characterization and optimization are performed at component level with a typical application environment and simplified MCU software. It should be noted that good EMC performance is highly dependent on the user application and the software in particular.

Therefore it is recommended that the user applies EMC software optimization and prequalification tests in relation with the EMC level requested for his application.

**Software recommendations**

The software flowchart must include the management of runaway conditions such as:

- Corrupted program counter
- Unexpected reset
- Critical Data corruption (control registers...)

**Prequalification trials**

Most of the common failures (unexpected reset and program counter corruption) can be reproduced by manually forcing a low state on the NRST pin or the Oscillator pins for 1 second.

To complete these trials, ESD stress can be applied directly on the device, over the range of specification values. When unexpected behavior is detected, the software can be hardened to prevent unrecoverable errors occurring (see application note AN1015).

**Electromagnetic Interference (EMI)**

The electromagnetic field emitted by the device are monitored while a simple application is executed (toggling 2 LEDs through the I/O ports). This emission test is compliant with IEC 61967-2 standard which specifies the test board and the pin loading.

**Table 46. EMI characteristics**

Symbol	Parameter	Conditions	Monitored frequency band	Max vs. [f <sub>HSE</sub> /f <sub>HCLK</sub> ]	Unit
				8/48 MHz	
S <sub>EMI</sub>	Peak level	V <sub>DD</sub> = 3.6 V, T <sub>A</sub> = 25 °C, LQFP48 package compliant with IEC 61967-2	0.1 to 30 MHz	-9	dBμV
			30 to 130 MHz	9	
			130 MHz to 1 GHz	17	
			EMI Level	3	-



### 6.3.12 Electrical sensitivity characteristics

Based on three different tests (ESD, LU) using specific measurement methods, the device is stressed in order to determine its performance in terms of electrical sensitivity.

#### Electrostatic discharge (ESD)

Electrostatic discharges (a positive then a negative pulse separated by 1 second) are applied to the pins of each sample according to each pin combination. The sample size depends on the number of supply pins in the device (3 parts × (n+1) supply pins). This test conforms to the JESD22-A114/C101 standard.

**Table 47. ESD absolute maximum ratings**

Symbol	Ratings	Conditions	Class	Maximum value <sup>(1)</sup>	Unit
V <sub>ESD(HBM)</sub>	Electrostatic discharge voltage (human body model)	T <sub>A</sub> = +25 °C, conforming to JESD22-A114	2	2000	V
V <sub>ESD(CDM)</sub>	Electrostatic discharge voltage (charge device model)	T <sub>A</sub> = +25 °C, conforming to ANSI/ESD STM5.3.1	II	500	

1. Data based on characterization results, not tested in production.

#### Static latch-up

Two complementary static tests are required on six parts to assess the latch-up performance:

- A supply overvoltage is applied to each power supply pin.
- A current injection is applied to each input, output and configurable I/O pin.

These tests are compliant with EIA/JESD 78A IC latch-up standard.

**Table 48. Electrical sensitivities**

Symbol	Parameter	Conditions	Class
LU	Static latch-up class	T <sub>A</sub> = +105 °C conforming to JESD78A	II level A

### 6.3.13 I/O current injection characteristics

As a general rule, current injection to the I/O pins, due to external voltage below V<sub>SS</sub> or above V<sub>DDIOx</sub> (for standard, 3.3 V-capable I/O pins) should be avoided during normal product operation. However, in order to give an indication of the robustness of the microcontroller in cases when abnormal injection accidentally happens, susceptibility tests are performed on a sample basis during device characterization.

### Functional susceptibility to I/O current injection

While a simple application is executed on the device, the device is stressed by injecting current into the I/O pins programmed in floating input mode. While current is injected into the I/O pin, one at a time, the device is checked for functional failures.

The failure is indicated by an out of range parameter: ADC error above a certain limit (higher than 5 LSB TUE), out of conventional limits of induced leakage current on adjacent pins (out of the  $-5 \mu\text{A}/+0 \mu\text{A}$  range) or other functional failure (for example reset occurrence or oscillator frequency deviation).

The characterization results are given in [Table 49](#).

Negative induced leakage current is caused by negative injection and positive induced leakage current is caused by positive injection.

**Table 49. I/O current injection susceptibility**

Symbol	Description	Functional susceptibility		Unit
		Negative injection	Positive injection	
I <sub>INJ</sub>	Injected current on PA12 pin	-0	+5	mA
	Injected current on PA9, PB3, PB13, PF11 pins with induced leakage current on adjacent pins less than 50 $\mu\text{A}$	-5	NA	
	Injected current on PB0, PB1 and all other FT and FTf pins	-5	NA	
	Injected current on all other TC, TTa and RST pins	-5	+5	

### 6.3.14 I/O port characteristics

#### General input/output characteristics

Unless otherwise specified, the parameters given in [Table 50](#) are derived from tests performed under the conditions summarized in [Table 21: General operating conditions](#). All I/Os are designed as CMOS- and TTL-compliant.

**Table 50. I/O static characteristics**

Symbol	Parameter	Conditions	Min	Typ	Max	Unit
V <sub>IL</sub>	Low level input voltage	TC and TTa I/O	-	-	$0.3 V_{\text{DDIOx}} + 0.07^{(1)}$	V
		FT and FTf I/O	-	-	$0.475 V_{\text{DDIOx}} - 0.2^{(1)}$	
		All I/Os	-	-	$0.3 V_{\text{DDIOx}}$	
V <sub>IH</sub>	High level input voltage	TC and TTa I/O	$0.445 V_{\text{DDIOx}} + 0.398^{(1)}$	-	-	V
		FT and FTf I/O	$0.5 V_{\text{DDIOx}} + 0.2^{(1)}$	-	-	
		All I/Os	$0.7 V_{\text{DDIOx}}$	-	-	
V <sub>hys</sub>	Schmitt trigger hysteresis	TC and TTa I/O	-	200 <sup>(1)</sup>	-	mV
		FT and FTf I/O	-	100 <sup>(1)</sup>	-	

Table 50. I/O static characteristics (continued)

Symbol	Parameter	Conditions	Min	Typ	Max	Unit
$I_{lkg}$	Input leakage current <sup>(2)</sup>	TC, FT and FTf I/O TTa in digital mode $V_{SS} \leq V_{IN} \leq V_{DDIOx}$	-	-	$\pm 0.1$	$\mu A$
		TTa in digital mode $V_{DDIOx} \leq V_{IN} \leq V_{DDA}$	-	-	1	
		TTa in analog mode $V_{SS} \leq V_{IN} \leq V_{DDA}$	-	-	$\pm 0.2$	
		FT and FTf I/O <sup>(3)</sup> $V_{DDIOx} \leq V_{IN} \leq 5 V$	-	-	10	
$R_{PU}$	Weak pull-up equivalent resistor <sup>(4)</sup>	$V_{IN} = V_{SS}$	25	40	55	$k\Omega$
$R_{PD}$	Weak pull-down equivalent resistor <sup>(4)</sup>	$V_{IN} = V_{DDIOx}$	25	40	55	$k\Omega$
$C_{IO}$	I/O pin capacitance		-	5	-	pF

1. Data based on design simulation only. Not tested in production.
2. The leakage could be higher than the maximum value, if negative current is injected on adjacent pins. Refer to [Table 49: I/O current injection susceptibility](#).
3. To sustain a voltage higher than  $V_{DDIOx} + 0.3 V$ , the internal pull-up/pull-down resistors must be disabled.
4. Pull-up and pull-down resistors are designed with a true resistance in series with a switchable PMOS/NMOS. This PMOS/NMOS contribution to the series resistance is minimal (~10% order).

All I/Os are CMOS- and TTL-compliant (no software configuration required). Their characteristics cover more than the strict CMOS-technology or TTL parameters. The coverage of these requirements is shown in *Figure 22* for standard I/Os, and in *Figure 23* for 5 V tolerant I/Os. The following curves are design simulation results, not tested in production.

Figure 22. TC and TTa I/O input characteristics

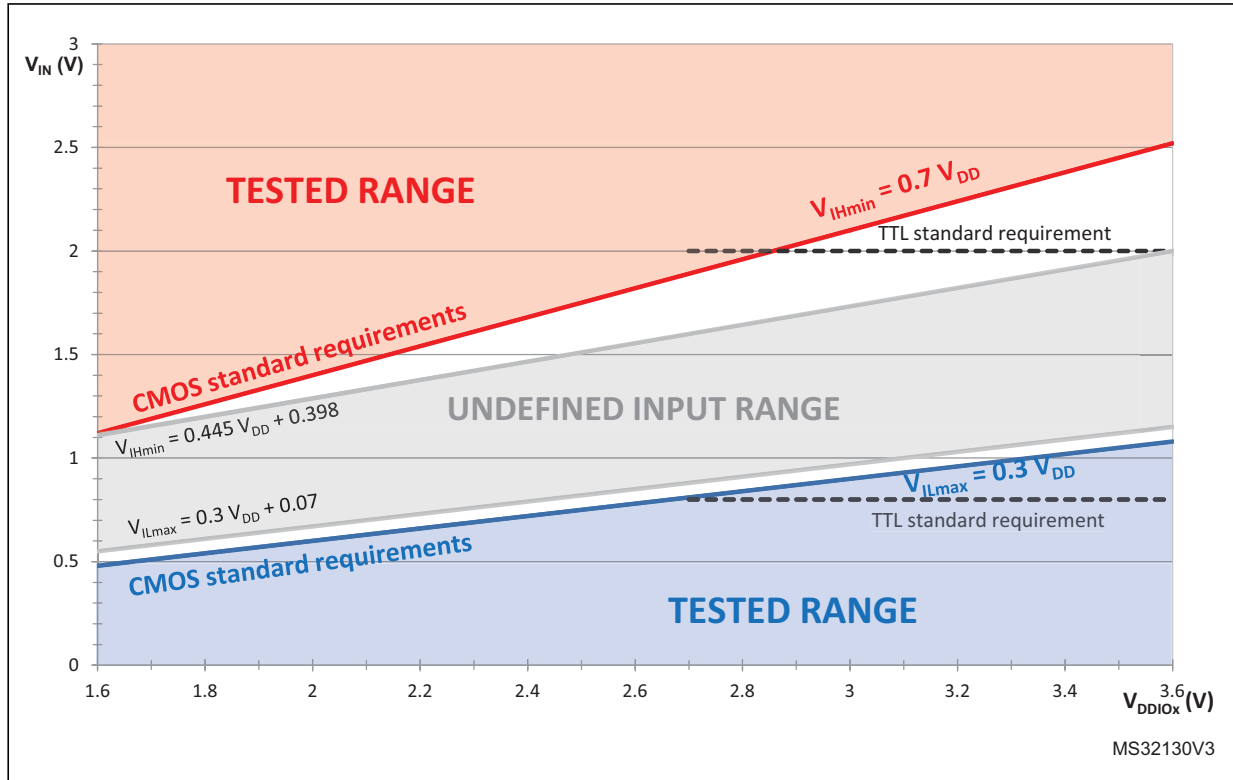
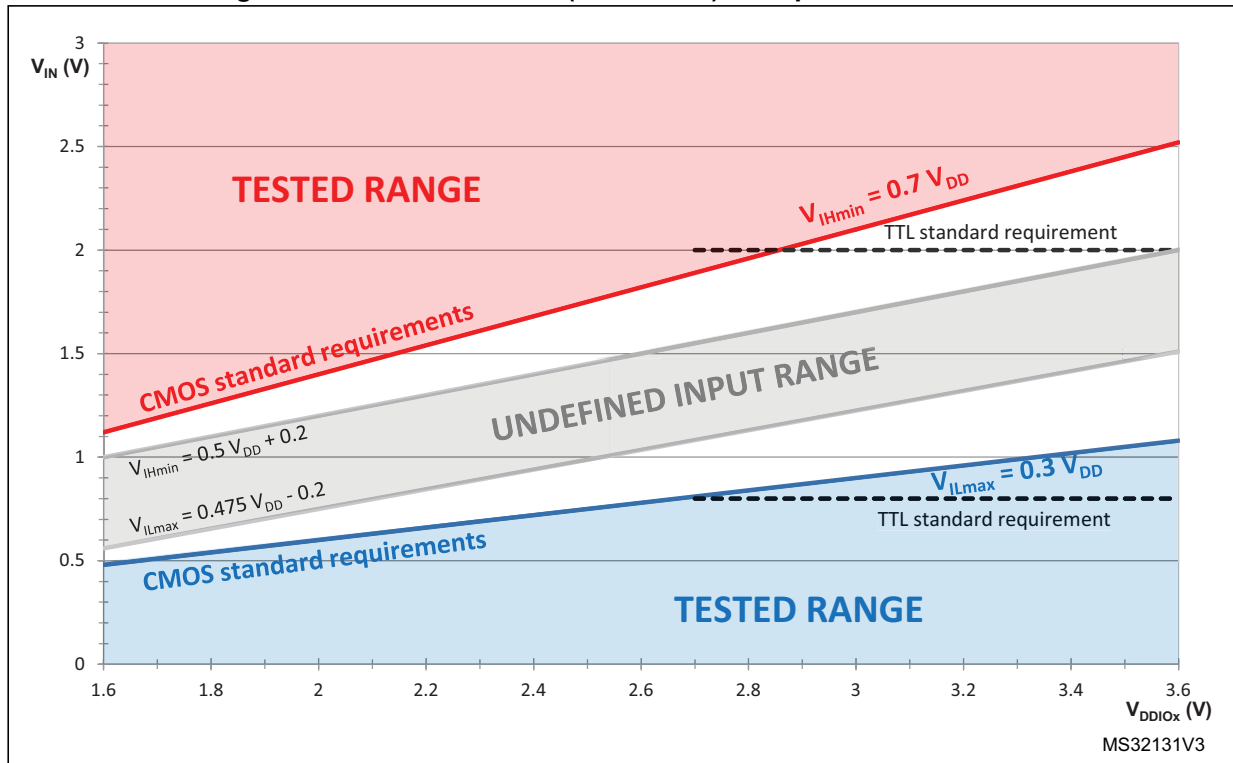

Figure 23. Five volt tolerant (FT and FTf) I/O input characteristics



### Output driving current

The GPIOs (general purpose input/outputs) can sink or source up to +/-8 mA, and sink or source up to +/- 20 mA (with a relaxed  $V_{OL}/V_{OH}$ ).

In the user application, the number of I/O pins which can drive current must be limited to respect the absolute maximum rating specified in [Section 6.2](#):

- The sum of the currents sourced by all the I/Os on  $V_{DDIOx}$ , plus the maximum consumption of the MCU sourced on  $V_{DD}$ , cannot exceed the absolute maximum rating  $\Sigma I_{VDD}$  (see [Table 18: Voltage characteristics](#)).
- The sum of the currents sunk by all the I/Os on  $V_{SS}$ , plus the maximum consumption of the MCU sunk on  $V_{SS}$ , cannot exceed the absolute maximum rating  $\Sigma I_{VSS}$  (see [Table 18: Voltage characteristics](#)).

### Output voltage levels

Unless otherwise specified, the parameters given in the table below are derived from tests performed under the ambient temperature and supply voltage conditions summarized in [Table 21: General operating conditions](#). All I/Os are CMOS- and TTL-compliant (FT, TTa or TC unless otherwise specified).

**Table 51. Output voltage characteristics<sup>(1)</sup>**

Symbol	Parameter	Conditions	Min	Max	Unit
$V_{OL}$	Output low level voltage for an I/O pin	CMOS port <sup>(2)</sup> $ I_{IO}  = 8 \text{ mA}$ $V_{DDIOx} \geq 2.7 \text{ V}$	-	0.4	V
$V_{OH}$	Output high level voltage for an I/O pin		$V_{DDIOx}-0.4$	-	
$V_{OL}$	Output low level voltage for an I/O pin	TTL port <sup>(2)</sup> $ I_{IO}  = 8 \text{ mA}$ $V_{DDIOx} \geq 2.7 \text{ V}$	-	0.4	V
$V_{OH}$	Output high level voltage for an I/O pin		2.4	-	
$V_{OL}^{(3)}$	Output low level voltage for an I/O pin	$ I_{IO}  = 20 \text{ mA}$ $V_{DDIOx} \geq 2.7 \text{ V}$	-	1.3	V
$V_{OH}^{(3)}$	Output high level voltage for an I/O pin		$V_{DDIOx}-1.3$	-	
$V_{OL}^{(3)}$	Output low level voltage for an I/O pin	$ I_{IO}  = 6 \text{ mA}$ $V_{DDIOx} \geq 2 \text{ V}$	-	0.4	V
$V_{OH}^{(3)}$	Output high level voltage for an I/O pin		$V_{DDIOx}-0.4$	-	
$V_{OL}^{(3)}$	Output low level voltage for an I/O pin	$ I_{IO}  = 4 \text{ mA}$	-	0.4	V
$V_{OH}^{(3)}$	Output high level voltage for an I/O pin		$V_{DDIOx}-0.4$	-	V
$V_{OLFm+}^{(3)}$	Output low level voltage for an FTf I/O pin in Fm+ mode	$ I_{IO}  = 20 \text{ mA}$ $V_{DDIOx} \geq 2.7 \text{ V}$	-	0.4	V
		$ I_{IO}  = 10 \text{ mA}$	-	0.4	V

1. The  $I_{IO}$  current sourced or sunk by the device must always respect the absolute maximum rating specified in [Table 18: Voltage characteristics](#), and the sum of the currents sourced or sunk by all the I/Os (I/O ports and control pins) must always respect the absolute maximum ratings  $\Sigma I_{IO}$ .
2. TTL and CMOS outputs are compatible with JEDEC standards JESD36 and JESD52.
3. Data based on characterization results. Not tested in production.



**Input/output AC characteristics**

The definition and values of input/output AC characteristics are given in *Figure 24* and *Table 52*, respectively.

Unless otherwise specified, the parameters given are derived from tests performed under the ambient temperature and supply voltage conditions summarized in *Table 21: General operating conditions*.

**Table 52. I/O AC characteristics<sup>(1)(2)</sup>**

OSPEEDRy [1:0] value <sup>(1)</sup>	Symbol	Parameter	Conditions	Min	Max	Unit
x0	f <sub>max(I/O)out</sub>	Maximum frequency <sup>(3)</sup>	C <sub>L</sub> = 50 pF, V <sub>DDIOx</sub> ≥ 2 V	-	2	MHz
	t <sub>f(I/O)out</sub>	Output fall time		-	125	ns
	t <sub>r(I/O)out</sub>	Output rise time		-	125	
	f <sub>max(I/O)out</sub>	Maximum frequency <sup>(3)</sup>	C <sub>L</sub> = 50 pF, V <sub>DDIOx</sub> < 2 V	-	1	MHz
	t <sub>f(I/O)out</sub>	Output fall time		-	125	ns
	t <sub>r(I/O)out</sub>	Output rise time		-	125	
01	f <sub>max(I/O)out</sub>	Maximum frequency <sup>(3)</sup>	C <sub>L</sub> = 50 pF, V <sub>DDIOx</sub> ≥ 2 V	-	10	MHz
	t <sub>f(I/O)out</sub>	Output fall time		-	25	ns
	t <sub>r(I/O)out</sub>	Output rise time		-	25	
	f <sub>max(I/O)out</sub>	Maximum frequency <sup>(3)</sup>	C <sub>L</sub> = 50 pF, V <sub>DDIOx</sub> < 2 V	-	4	MHz
	t <sub>f(I/O)out</sub>	Output fall time		-	62.5	ns
	t <sub>r(I/O)out</sub>	Output rise time		-	62.5	
11	f <sub>max(I/O)out</sub>	Maximum frequency <sup>(3)</sup>	C <sub>L</sub> = 30 pF, V <sub>DDIOx</sub> ≥ 2.7 V	-	50	MHz
			C <sub>L</sub> = 50 pF, V <sub>DDIOx</sub> ≥ 2.7 V	-	30	
			C <sub>L</sub> = 50 pF, 2 V ≤ V <sub>DDIOx</sub> < 2.7 V	-	20	
			C <sub>L</sub> = 50 pF, V <sub>DDIOx</sub> < 2 V	-	10	
	t <sub>f(I/O)out</sub>	Output fall time	C <sub>L</sub> = 30 pF, V <sub>DDIOx</sub> ≥ 2.7 V	-	5	ns
			C <sub>L</sub> = 50 pF, V <sub>DDIOx</sub> ≥ 2.7 V	-	8	
			C <sub>L</sub> = 50 pF, 2 V ≤ V <sub>DDIOx</sub> < 2.7 V	-	12	
			C <sub>L</sub> = 50 pF, V <sub>DDIOx</sub> < 2 V	-	25	
	t <sub>r(I/O)out</sub>	Output rise time	C <sub>L</sub> = 30 pF, V <sub>DDIOx</sub> ≥ 2.7 V	-	5	
			C <sub>L</sub> = 50 pF, V <sub>DDIOx</sub> ≥ 2.7 V	-	8	
			C <sub>L</sub> = 50 pF, 2 V ≤ V <sub>DDIOx</sub> < 2.7 V	-	12	
			C <sub>L</sub> = 50 pF, V <sub>DDIOx</sub> < 2 V	-	25	

Table 52. I/O AC characteristics<sup>(1)(2)</sup> (continued)

OSPEEDRx[1:0] value <sup>(1)</sup>	Symbol	Parameter	Conditions	Min	Max	Unit
Fm+ configuration <sup>(4)</sup>	f <sub>max(I/O)out</sub>	Maximum frequency <sup>(3)</sup>	C <sub>L</sub> = 50 pF, V <sub>DDIOx</sub> ≥ 2 V	-	2	MHz
	t <sub>f(I/O)out</sub>	Output fall time		-	12	ns
	t <sub>r(I/O)out</sub>	Output rise time		-	34	
	f <sub>max(I/O)out</sub>	Maximum frequency <sup>(3)</sup>	C <sub>L</sub> = 50 pF, V <sub>DDIOx</sub> < 2 V	-	0.5	MHz
	t <sub>f(I/O)out</sub>	Output fall time		-	16	ns
	t <sub>r(I/O)out</sub>	Output rise time		-	44	
	t <sub>EXTIpw</sub>	Pulse width of external signals detected by the EXTI controller		10	-	ns

1. The I/O speed is configured using the OSPEEDRx[1:0] bits. Refer to the STM32F0xxx RM0091 reference manual for a description of GPIO Port configuration register.
2. Guaranteed by design, not tested in production.
3. The maximum frequency is defined in Figure 24.
4. When Fm+ configuration is set, the I/O speed control is bypassed. Refer to the STM32F0xxx reference manual RM0091 for a detailed description of Fm+ I/O configuration.

Figure 24. I/O AC characteristics definition

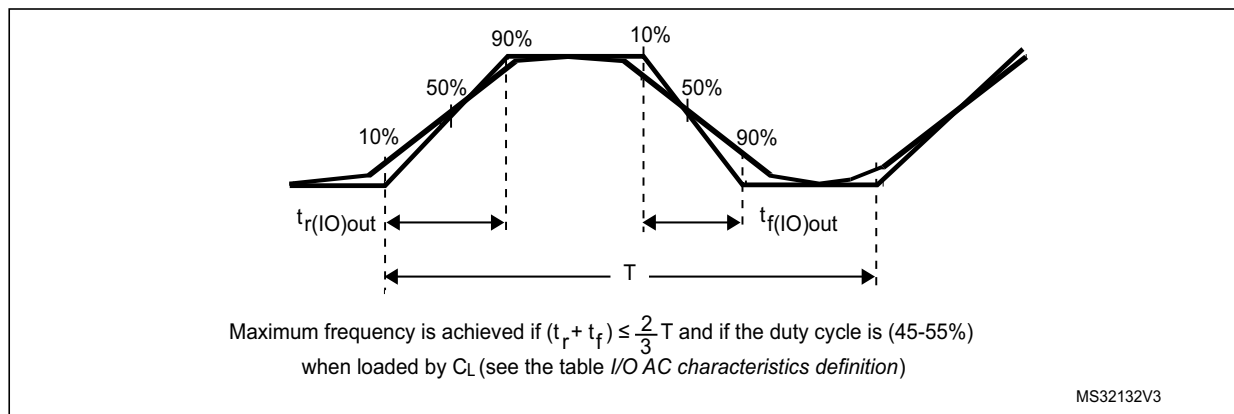

### 6.3.15 NRST pin characteristics

The NRST pin input driver uses the CMOS technology. It is connected to a permanent pull-up resistor, R<sub>PJ</sub>.

Unless otherwise specified, the parameters given in the table below are derived from tests performed under the ambient temperature and supply voltage conditions summarized in Table 21: General operating conditions.

Table 53. NRST pin characteristics

Symbol	Parameter	Conditions	Min	Typ	Max	Unit
V <sub>IL(NRST)</sub>	NRST input low level voltage		-	-	0.3 V <sub>DD</sub> +0.07 <sup>(1)</sup>	V
V <sub>IH(NRST)</sub>	NRST input high level voltage		0.445 V <sub>DD</sub> +0.398 <sup>(1)</sup>	-	-	

**Table 53. NRST pin characteristics (continued)**

Symbol	Parameter	Conditions	Min	Typ	Max	Unit
$V_{hys(NRST)}$	NRST Schmitt trigger voltage hysteresis		-	200	-	mV
$R_{PU}$	Weak pull-up equivalent resistor <sup>(2)</sup>	$V_{IN} = V_{SS}$	25	40	55	k $\Omega$
$V_{F(NRST)}$	NRST input filtered pulse		-	-	100 <sup>(1)</sup>	ns
$V_{NF(NRST)}$	NRST input not filtered pulse	$2.7 < V_{DD} < 3.6$	300 <sup>(3)</sup>	-	-	ns
		$2.0 < V_{DD} < 3.6$	500 <sup>(3)</sup>	-	-	

1. Data based on design simulation only. Not tested in production.
2. The pull-up is designed with a true resistance in series with a switchable PMOS. This PMOS contribution to the series resistance is minimal (~10% order).
3. Data based on design simulation only. Not tested in production.

**Figure 25. Recommended NRST pin protection**

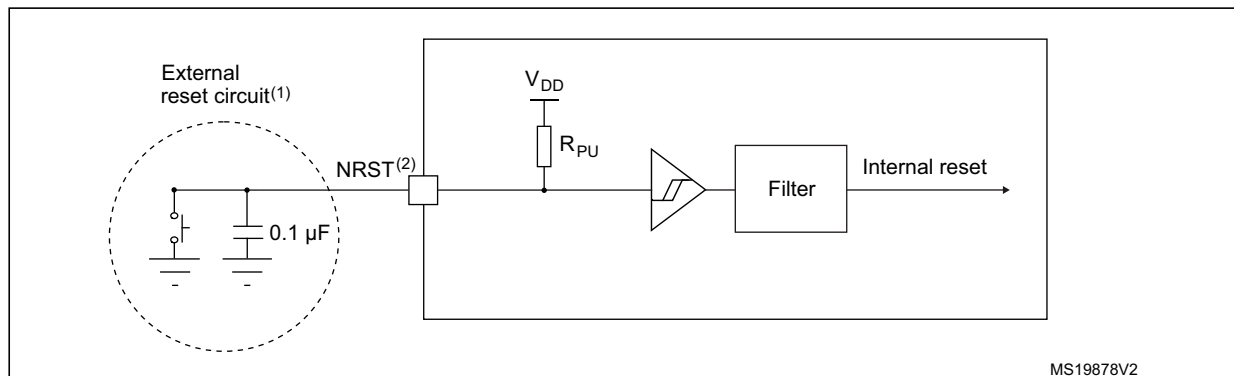

1. The external capacitor protects the device against parasitic resets.
2. The user must ensure that the level on the NRST pin can go below the  $V_{IL(NRST)}$  max level specified in [Table 53: NRST pin characteristics](#). Otherwise the reset will not be taken into account by the device.

### 6.3.16 12-bit ADC characteristics

Unless otherwise specified, the parameters given in [Table 54](#) are preliminary values derived from tests performed under ambient temperature,  $f_{PCLK}$  frequency and  $V_{DDA}$  supply voltage conditions summarized in [Table 21: General operating conditions](#).

*Note:* It is recommended to perform a calibration after each power-up.

**Table 54. ADC characteristics**

Symbol	Parameter	Conditions	Min	Typ	Max	Unit
$V_{DDA}$	Analog supply voltage for ADC ON		2.4	-	3.6	V
$I_{DDA(ADC)}$	Current consumption of the ADC <sup>(1)</sup>	$V_{DD} = V_{DDA} = 3.3 V$	-	0.9	-	mA
$f_{ADC}$	ADC clock frequency		0.6	-	14	MHz
$f_S^{(2)}$	Sampling rate		0.05	-	1	MHz

Table 54. ADC characteristics (continued)

Symbol	Parameter	Conditions	Min	Typ	Max	Unit
f <sub>TRIG</sub> <sup>(2)</sup>	External trigger frequency	f <sub>ADC</sub> = 14 MHz	-	-	823	kHz
			-	-	17	1/f <sub>ADC</sub>
V <sub>AIN</sub>	Conversion voltage range		0	-	V <sub>DDA</sub>	V
R <sub>AIN</sub> <sup>(2)</sup>	External input impedance	See <i>Equation 1</i> and <i>Table 55</i> for details	-	-	50	kΩ
R <sub>ADC</sub> <sup>(2)</sup>	Sampling switch resistance		-	-	1	kΩ
C <sub>ADC</sub> <sup>(2)</sup>	Internal sample and hold capacitor		-	-	8	pF
t <sub>CAL</sub> <sup>(2)</sup>	Calibration time	f <sub>ADC</sub> = 14 MHz	5.9			μs
			83			1/f <sub>ADC</sub>
W <sub>LATENCY</sub> <sup>(2)</sup>	ADC_DR register write latency	ADC clock = HSI14	1.5 ADC cycles + 2 f <sub>PCLK</sub> cycles	-	1.5 ADC cycles + 3 f <sub>PCLK</sub> cycles	
		ADC clock = PCLK/2	-	4.5	-	f <sub>PCLK</sub> cycle
		ADC clock = PCLK/4	-	8.5	-	f <sub>PCLK</sub> cycle
t <sub>itr</sub> <sup>(2)</sup>	Trigger conversion latency	f <sub>ADC</sub> = f <sub>PCLK</sub> /2 = 14 MHz	0.196			μs
		f <sub>ADC</sub> = f <sub>PCLK</sub> /2	5.5			1/f <sub>PCLK</sub>
		f <sub>ADC</sub> = f <sub>PCLK</sub> /4 = 12 MHz	0.219			μs
		f <sub>ADC</sub> = f <sub>PCLK</sub> /4	10.5			1/f <sub>PCLK</sub>
		f <sub>ADC</sub> = f <sub>HSI14</sub> = 14 MHz	0.188	-	0.259	μs
Jitter <sub>ADC</sub>	ADC jitter on trigger conversion	f <sub>ADC</sub> = f <sub>HSI14</sub>	-	1	-	1/f <sub>HSI14</sub>
t <sub>S</sub> <sup>(2)</sup>	Sampling time	f <sub>ADC</sub> = 14 MHz	0.107	-	17.1	μs
			1.5	-	239.5	1/f <sub>ADC</sub>
t <sub>STAB</sub> <sup>(2)</sup>	Power-up time		0	0	1	μs
t <sub>CONV</sub> <sup>(2)</sup>	Total conversion time (including sampling time)	f <sub>ADC</sub> = 14 MHz	1	-	18	μs
			14 to 252 (t <sub>S</sub> for sampling +12.5 for successive approximation)			1/f <sub>ADC</sub>

1. During conversion of the sampled value (12.5 x ADC clock period), an additional consumption of 100 μA on I<sub>DDA</sub> and 60 μA on I<sub>DD</sub> should be taken into account.
2. Guaranteed by design, not tested in production.

**Equation 1: R<sub>AIN</sub> max formula**

$$R_{AIN} < \frac{T_S}{f_{ADC} \times C_{ADC} \times \ln(2^{N+2})} - R_{ADC}$$

The formula above (*Equation 1*) is used to determine the maximum external impedance allowed for an error below 1/4 of LSB. Here N = 12 (from 12-bit resolution).

**Table 55. R<sub>AIN</sub> max for f<sub>ADC</sub> = 14 MHz**

T <sub>s</sub> (cycles)	t <sub>s</sub> (μs)	R <sub>AIN</sub> max (kΩ) <sup>(1)</sup>
1.5	0.11	0.4
7.5	0.54	5.9
13.5	0.96	11.4
28.5	2.04	25.2
41.5	2.96	37.2
55.5	3.96	50
71.5	5.11	NA
239.5	17.1	NA

1. Guaranteed by design, not tested in production.

**Table 56. ADC accuracy<sup>(1)(2)(3)</sup>**

Symbol	Parameter	Test conditions	Typ	Max <sup>(4)</sup>	Unit
ET	Total unadjusted error	f <sub>PCLK</sub> = 48 MHz, f <sub>ADC</sub> = 14 MHz, R <sub>AIN</sub> < 10 kΩ V <sub>DDA</sub> = 3 V to 3.6 V T <sub>A</sub> = 25 °C	±1.3	±2	LSB
EO	Offset error		±1	±1.5	
EG	Gain error		±0.5	±1.5	
ED	Differential linearity error		±0.7	±1	
EL	Integral linearity error		±0.8	±1.5	
ET	Total unadjusted error	f <sub>PCLK</sub> = 48 MHz, f <sub>ADC</sub> = 14 MHz, R <sub>AIN</sub> < 10 kΩ V <sub>DDA</sub> = 2.7 V to 3.6 V T <sub>A</sub> = -40 to 105 °C	±3.3	±4	LSB
EO	Offset error		±1.9	±2.8	
EG	Gain error		±2.8	±3	
ED	Differential linearity error		±0.7	±1.3	
EL	Integral linearity error		±1.2	±1.7	
ET	Total unadjusted error	f <sub>PCLK</sub> = 48 MHz, f <sub>ADC</sub> = 14 MHz, R <sub>AIN</sub> < 10 kΩ V <sub>DDA</sub> = 2.4 V to 3.6 V T <sub>A</sub> = 25 °C	±3.3	±4	LSB
EO	Offset error		±1.9	±2.8	
EG	Gain error		±2.8	±3	
ED	Differential linearity error		±0.7	±1.3	
EL	Integral linearity error		±1.2	±1.7	

- ADC DC accuracy values are measured after internal calibration.
- ADC Accuracy vs. Negative Injection Current: Injecting negative current on any of the standard (non-robust) analog input pins should be avoided as this significantly reduces the accuracy of the conversion being performed on another analog input. It is recommended to add a Schottky diode (pin to ground) to standard analog pins which may potentially inject negative current.  
Any positive injection current within the limits specified for I<sub>INJ(PIN)</sub> and ΣI<sub>INJ(PIN)</sub> in *Section 6.3.14* does not affect the ADC accuracy.
- Better performance may be achieved in restricted V<sub>DDA</sub>, frequency and temperature ranges.
- Data based on characterization results, not tested in production.

Figure 26. ADC accuracy characteristics

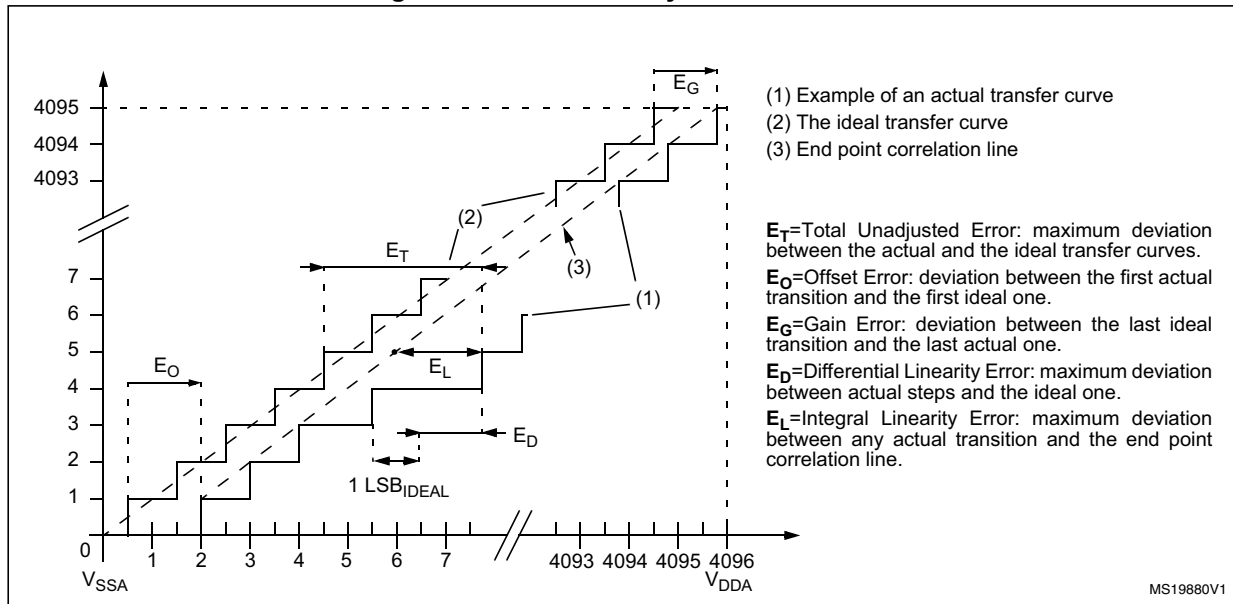
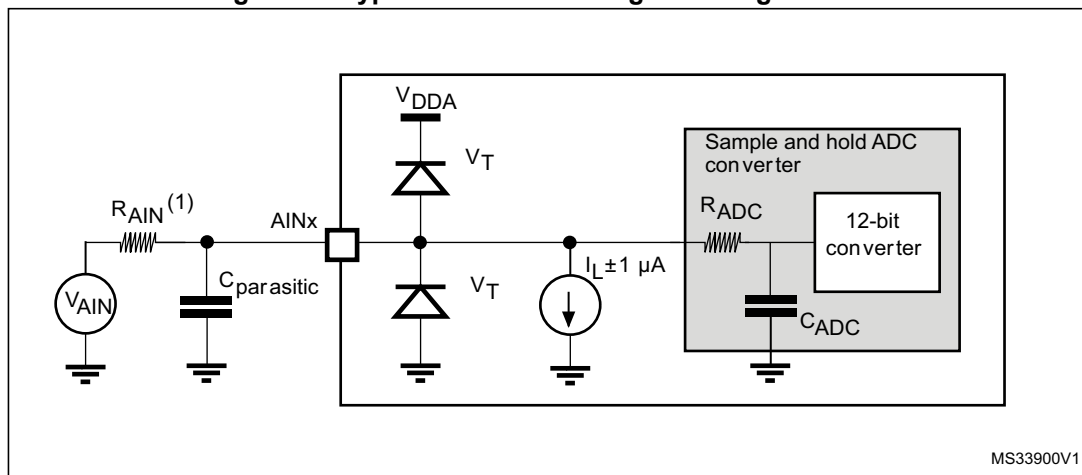

Figure 27. Typical connection diagram using the ADC



1. Refer to [Table 54: ADC characteristics](#) for the values of  $R_{AIN}$ ,  $R_{ADC}$  and  $C_{ADC}$ .
2.  $C_{parasitic}$  represents the capacitance of the PCB (dependent on soldering and PCB layout quality) plus the pad capacitance (roughly 7 pF). A high  $C_{parasitic}$  value will downgrade conversion accuracy. To remedy this,  $f_{ADC}$  should be reduced.

**General PCB design guidelines**

Power supply decoupling should be performed as shown in [Figure 13: Power supply scheme](#). The 10 nF capacitor should be ceramic (good quality) and it should be placed as close as possible to the chip.

### 6.3.17 Temperature sensor characteristics

Table 57. TS characteristics

Symbol	Parameter	Min	Typ	Max	Unit
$T_L^{(1)}$	$V_{SENSE}$ linearity with temperature	-	$\pm 1$	$\pm 2$	$^{\circ}C$
Avg_Slope <sup>(1)</sup>	Average slope	4.0	4.3	4.6	mV/ $^{\circ}C$
$V_{30}$	Voltage at 30 $^{\circ}C$ ( $\pm 5$ $^{\circ}C$ ) <sup>(2)</sup>	1.34	1.43	1.52	V
$t_{START}^{(1)}$	Startup time	4	-	10	$\mu s$
$t_{S\_temp}^{(1)}$	ADC sampling time when reading the temperature	4	-	-	$\mu s$

1. Guaranteed by design, not tested in production.
2. Measured at  $V_{DDA} = 3.3 V \pm 10 mV$ . The  $V_{30}$  ADC conversion result is stored in the TS\_CAL1 byte. Refer to [Table 3: Temperature sensor calibration values](#).

### 6.3.18 $V_{BAT}$ monitoring characteristics

Table 58.  $V_{BAT}$  monitoring characteristics

Symbol	Parameter	Min	Typ	Max	Unit
R	Resistor bridge for $V_{BAT}$	-	50	-	$k\Omega$
Q	Ratio on $V_{BAT}$ measurement	-	2	-	
$Er^{(1)}$	Error on Q	-1	-	+1	%
$t_{S\_vbat}^{(1)}$	ADC sampling time when reading the $V_{BAT}$	4	-	-	$\mu s$

1. Guaranteed by design, not tested in production.

### 6.3.19 Timer characteristics

The parameters given in the following tables are guaranteed by design.

Refer to [Section 6.3.14: I/O port characteristics](#) for details on the input/output alternate function characteristics (output compare, input capture, external clock, PWM output).

Table 59. TIMx characteristics

Symbol	Parameter	Conditions	Min	Max	Unit
$t_{res(TIM)}$	Timer resolution time		1	-	$t_{TIMxCLK}$
		$f_{TIMxCLK} = 48 MHz$	20.8	-	ns
$f_{EXT}$	Timer external clock frequency on CH1 to CH4		0	$f_{TIMxCLK}/2$	MHz
		$f_{TIMxCLK} = 48 MHz$	0	24	MHz
$Res_{TIM}$	Timer resolution	TIMx (except TIM2)	-	16	bit
		TIM2	-	32	
$t_{COUNTER}$	16-bit counter clock period		1	65536	$t_{TIMxCLK}$
		$f_{TIMxCLK} = 48 MHz$	0.0208	1365	$\mu s$

**Table 59. TIMx characteristics (continued)**

Symbol	Parameter	Conditions	Min	Max	Unit
t <sub>MAX_COUNT</sub>	Maximum possible count with 32-bit counter		-	65536 × 65536	t <sub>TIMxCLK</sub>
		f <sub>TIMxCLK</sub> = 48 MHz	-	89.48	s

**Table 60. IWDG min/max timeout period at 40 kHz (LSI)<sup>(1)</sup>**

Prescaler divider	PR[2:0] bits	Min timeout RL[11:0]= 0x000	Max timeout RL[11:0]= 0xFFFF	Unit
/4	0	0.1	409.6	ms
/8	1	0.2	819.2	
/16	2	0.4	1638.4	
/32	3	0.8	3276.8	
/64	4	1.6	6553.6	
/128	5	3.2	13107.2	
/256	6 or 7	6.4	26214.4	

1. These timings are given for a 40 kHz clock but the microcontroller internal RC frequency can vary from 30 to 60 kHz. Moreover, given an exact RC oscillator frequency, the exact timings still depend on the phasing of the APB interface clock versus the LSI clock so that there is always a full RC period of uncertainty.

**Table 61. WWDG min/max timeout value at 48 MHz (PCLK)**

Prescaler	WDGTB	Min timeout value	Max timeout value	Unit
1	0	0.0853	5.4613	ms
2	1	0.1706	10.9226	
4	2	0.3413	21.8453	
8	3	0.6826	43.6906	

### 6.3.20 Communication interfaces

#### I<sup>2</sup>C interface characteristics

The I2C interface meets the timings requirements of the I<sup>2</sup>C-bus specification and user manual rev. 03 for:

- Standard-mode (Sm): with a bit rate up to 100 kbit/s
- Fast-mode (Fm): with a bit rate up to 400 kbit/s
- Fast-mode Plus (Fm+): with a bit rate up to 1 Mbit/s.

The I2C timings requirements are guaranteed by design when the I2C peripheral is properly configured (refer to Reference manual).

The SDA and SCL I/O requirements are met with the following restrictions: the SDA and SCL I/O pins are not “true” open-drain. When configured as open-drain, the PMOS connected between the I/O pin and V<sub>DDIOx</sub> is disabled, but is still present. Only FTf I/O pins support Fm+ low level output current maximum requirement. Refer to [Section 6.3.14: I/O port characteristics](#) for the I2C I/Os characteristics.



All I2C SDA and SCL I/Os embed an analog filter. Refer to the table below for the analog filter characteristics:

**Table 62. I2C analog filter characteristics<sup>(1)</sup>**

Symbol	Parameter	Min	Max	Unit
$t_{AF}$	Maximum pulse width of spikes that are suppressed by the analog filter	50 <sup>(2)</sup>	260 <sup>(3)</sup>	ns

1. Guaranteed by design, not tested in production.
2. Spikes with widths below  $t_{AF(min)}$  are filtered.
3. Spikes with widths above  $t_{AF(max)}$  are not filtered

**SPI/I<sup>2</sup>S characteristics**

Unless otherwise specified, the parameters given in [Table 63](#) for SPI or in [Table 64](#) for I<sup>2</sup>S are derived from tests performed under the ambient temperature, f<sub>PCLKX</sub> frequency and supply voltage conditions summarized in [Table 21: General operating conditions](#).

Refer to [Section 6.3.14: I/O port characteristics](#) for more details on the input/output alternate function characteristics (NSS, SCK, MOSI, MISO for SPI and WS, CK, SD for I<sup>2</sup>S).

**Table 63. SPI characteristics<sup>(1)</sup>**

Symbol	Parameter	Conditions	Min	Max	Unit	
f <sub>SCK</sub> 1/t <sub>c(SCK)</sub>	SPI clock frequency	Master mode	-	18	MHz	
		Slave mode	-	18		
t <sub>r(SCK)</sub> t <sub>f(SCK)</sub>	SPI clock rise and fall time	Capacitive load: C = 15 pF	-	6	ns	
t <sub>su(NSS)</sub>	NSS setup time	Slave mode	4Tpclk	-	ns	
t <sub>h(NSS)</sub>	NSS hold time	Slave mode	2Tpclk + 10	-		
t <sub>w(SCKH)</sub> t <sub>w(SCKL)</sub>	SCK high and low time	Master mode, f <sub>PCLK</sub> = 36 MHz, presc = 4	Tpclk/2 - 2	Tpclk/2 + 1		
t <sub>su(MI)</sub> t <sub>su(SI)</sub>	Data input setup time	Master mode	4	-		
		Slave mode	5	-		
t <sub>h(MI)</sub> t <sub>h(SI)</sub>	Data input hold time	Master mode	4	-		
		Slave mode	5	-		
t <sub>a(SO)</sub> <sup>(2)</sup>	Data output access time	Slave mode, f <sub>PCLK</sub> = 20 MHz	0	3Tpclk		
t <sub>dis(SO)</sub> <sup>(3)</sup>	Data output disable time	Slave mode	0	18		
t <sub>v(SO)</sub>	Data output valid time	Slave mode (after enable edge)	-	22.5		
t <sub>v(MO)</sub>	Data output valid time	Master mode (after enable edge)	-	6		
t <sub>h(SO)</sub> t <sub>h(MO)</sub>	Data output hold time	Slave mode (after enable edge)	11.5	-		
		Master mode (after enable edge)	2	-		
DuCy(SCK)	SPI slave input clock duty cycle	Slave mode	25	75		%

1. Data based on characterization results, not tested in production.
2. Min time is for the minimum time to drive the output and the max time is for the maximum time to validate the data.
3. Min time is for the minimum time to invalidate the output and the max time is for the maximum time to put the data in Hi-Z

Figure 28. SPI timing diagram - slave mode and CPHA = 0

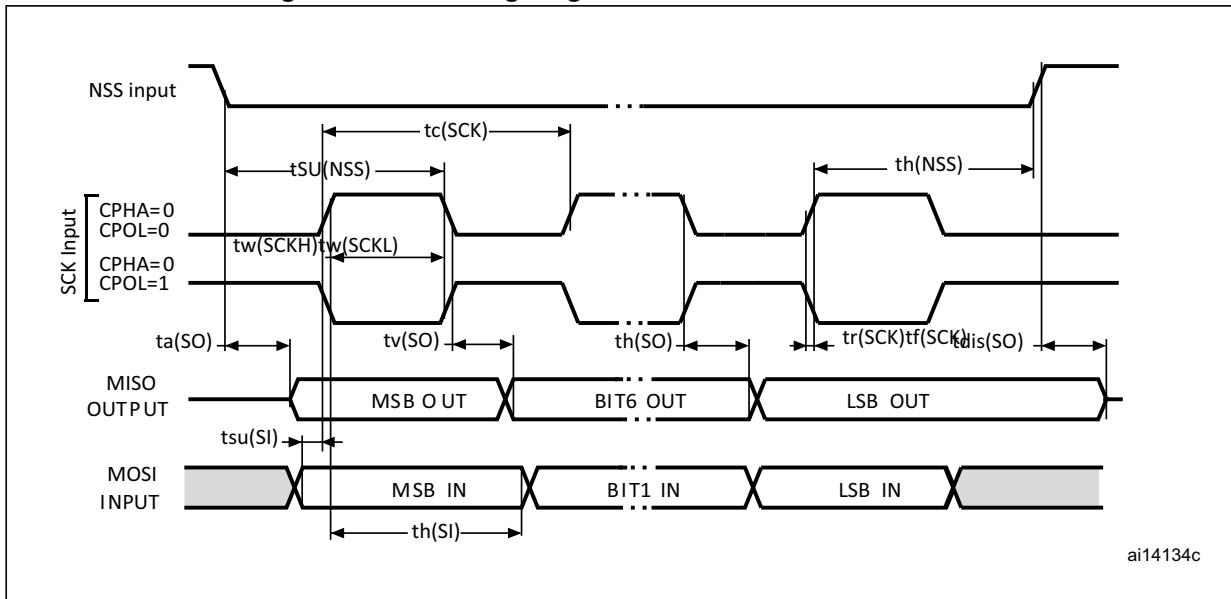
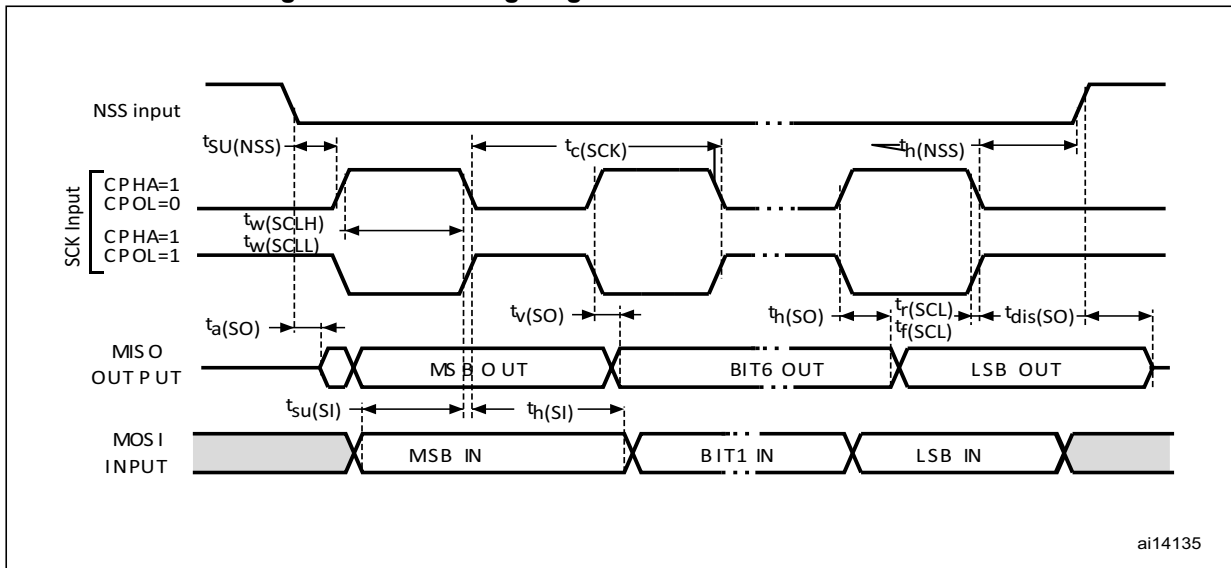
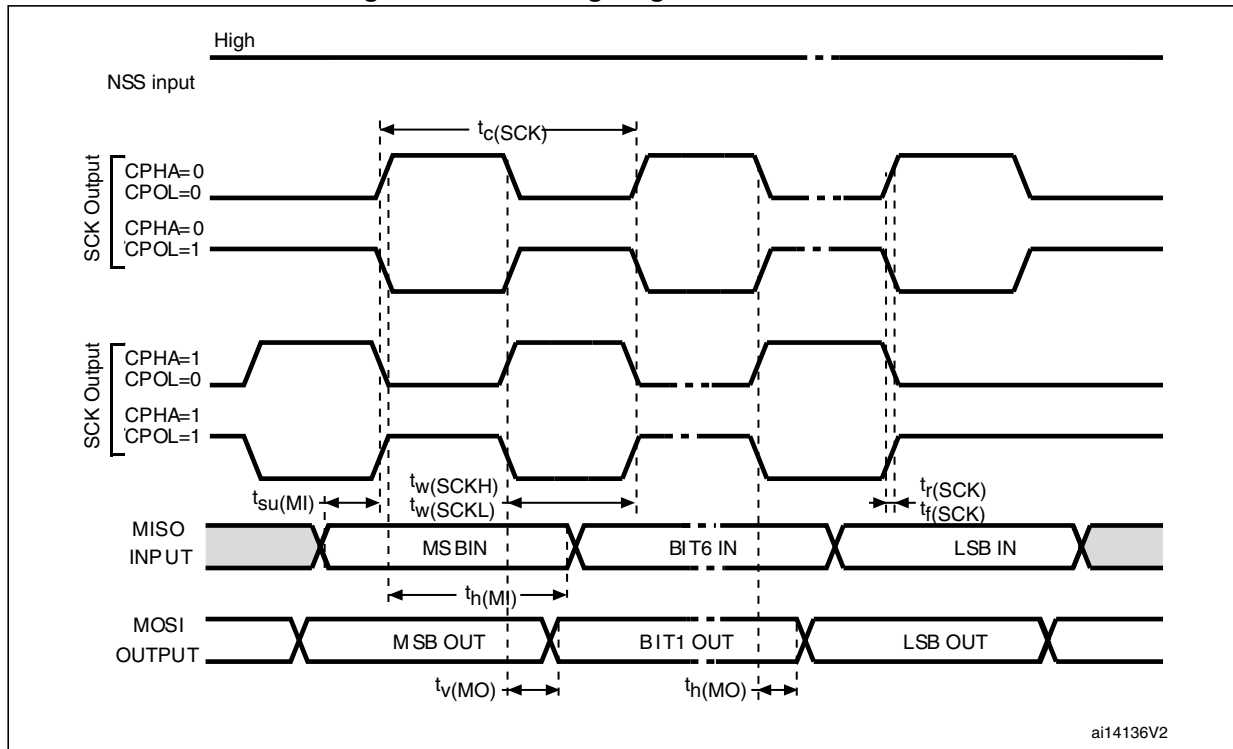

Figure 29. SPI timing diagram - slave mode and CPHA = 1



1. Measurement points are done at CMOS levels: 0.3  $V_{DD}$  and 0.7  $V_{DD}$ .

Figure 30. SPI timing diagram - master mode



1. Measurement points are done at CMOS levels: 0.3 V<sub>DD</sub> and 0.7 V<sub>DD</sub>.

Table 64. I<sup>2</sup>S characteristics<sup>(1)</sup>

Symbol	Parameter	Conditions	Min	Max	Unit
$f_{CK}$ $1/t_c(CK)$	I <sup>2</sup> S clock frequency	Master mode (data: 16 bits, Audio frequency = 48 kHz)	1.597	1.601	MHz
		Slave mode	0	6.5	
$t_r(CK)$	I <sup>2</sup> S clock rise time	Capacitive load C <sub>L</sub> = 15 pF	-	10	ns
$t_f(CK)$	I <sup>2</sup> S clock fall time		-	12	
$t_w(CKH)$	I2S clock high time	Master $f_{PCLK} = 16$ MHz, audio frequency = 48 kHz	306	-	
$t_w(CKL)$	I2S clock low time		312	-	
$t_v(WS)$	WS valid time	Master mode	2	-	
$t_h(WS)$	WS hold time	Master mode	2	-	
$t_{su}(WS)$	WS setup time	Slave mode	7	-	
$t_h(WS)$	WS hold time	Slave mode	0	-	
DuCy(SCK)	I2S slave input clock duty cycle	Slave mode	25	75	

Table 64. I<sup>2</sup>S characteristics<sup>(1)</sup> (continued)

Symbol	Parameter	Conditions	Min	Max	Unit
$t_{su(SD\_MR)}$	Data input setup time	Master receiver	6	-	ns
$t_{su(SD\_SR)}$	Data input setup time	Slave receiver	2	-	
$t_h(SD\_MR)^{(2)}$	Data input hold time	Master receiver	4	-	
$t_h(SD\_SR)^{(2)}$		Slave receiver	0.5	-	
$t_v(SD\_ST)^{(2)}$	Data output valid time	Slave transmitter (after enable edge)	-	-	
$t_h(SD\_ST)$	Data output hold time	Slave transmitter (after enable edge)	13	-	
$t_v(SD\_MT)^{(2)}$	Data output valid time	Master transmitter (after enable edge)	-	4	
$t_h(SD\_MT)$	Data output hold time	Master transmitter (after enable edge)	0	-	

1. Data based on design simulation and/or characterization results, not tested in production.
2. Depends on  $f_{PCLK}$ . For example, if  $f_{PCLK} = 8$  MHz, then  $T_{PCLK} = 1/f_{PCLK} = 125$  ns.

Figure 31. I2S slave timing diagram (Philips protocol)

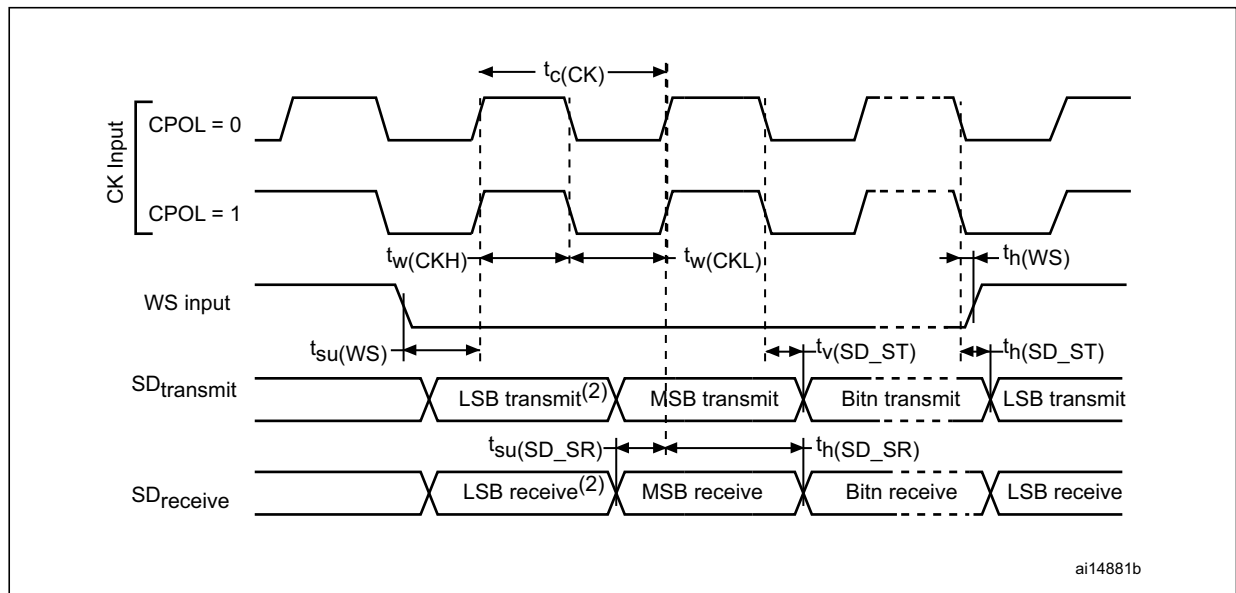

1. Measurement points are done at CMOS levels:  $0.3 \times V_{DDIOx}$  and  $0.7 \times V_{DDIOx}$ .
2. LSB transmit/receive of the previously transmitted byte. No LSB transmit/receive is sent before the first byte.

Figure 32. I2S master timing diagram (Philips protocol)

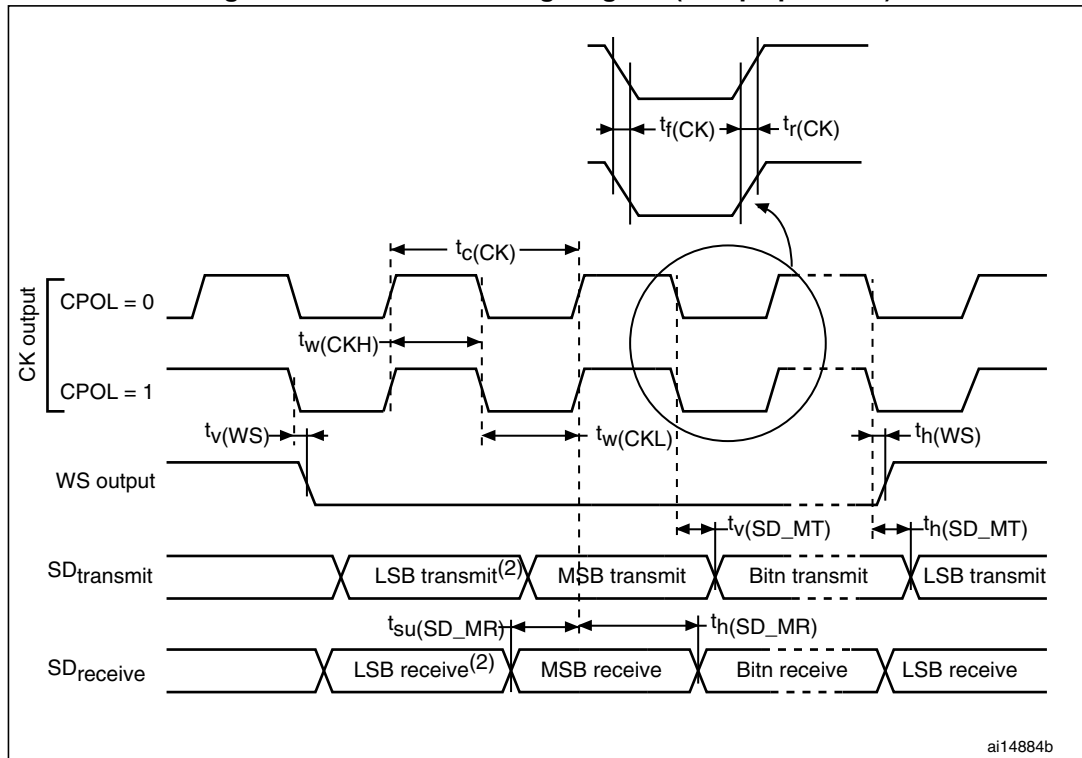

1. Data based on characterization results, not tested in production.
2. LSB transmit/receive of the previously transmitted byte. No LSB transmit/receive is sent before the first byte.

**CAN (controller area network) interface**

Refer to [Section 6.3.14: I/O port characteristics](#) for more details on the input/output alternate function characteristics (CAN\_TX and CAN\_RX).

## 7 Package characteristics

### 7.1 Package mechanical data

In order to meet environmental requirements, ST offers these devices in different grades of ECOPACK<sup>®</sup> packages, depending on their level of environmental compliance. ECOPACK<sup>®</sup> specifications, grade definitions and product status are available at: [www.st.com](http://www.st.com). ECOPACK<sup>®</sup> is an ST trademark.

Figure 33. LQFP48 – 7 mm x 7 mm, 48 pin low-profile quad flat package outline

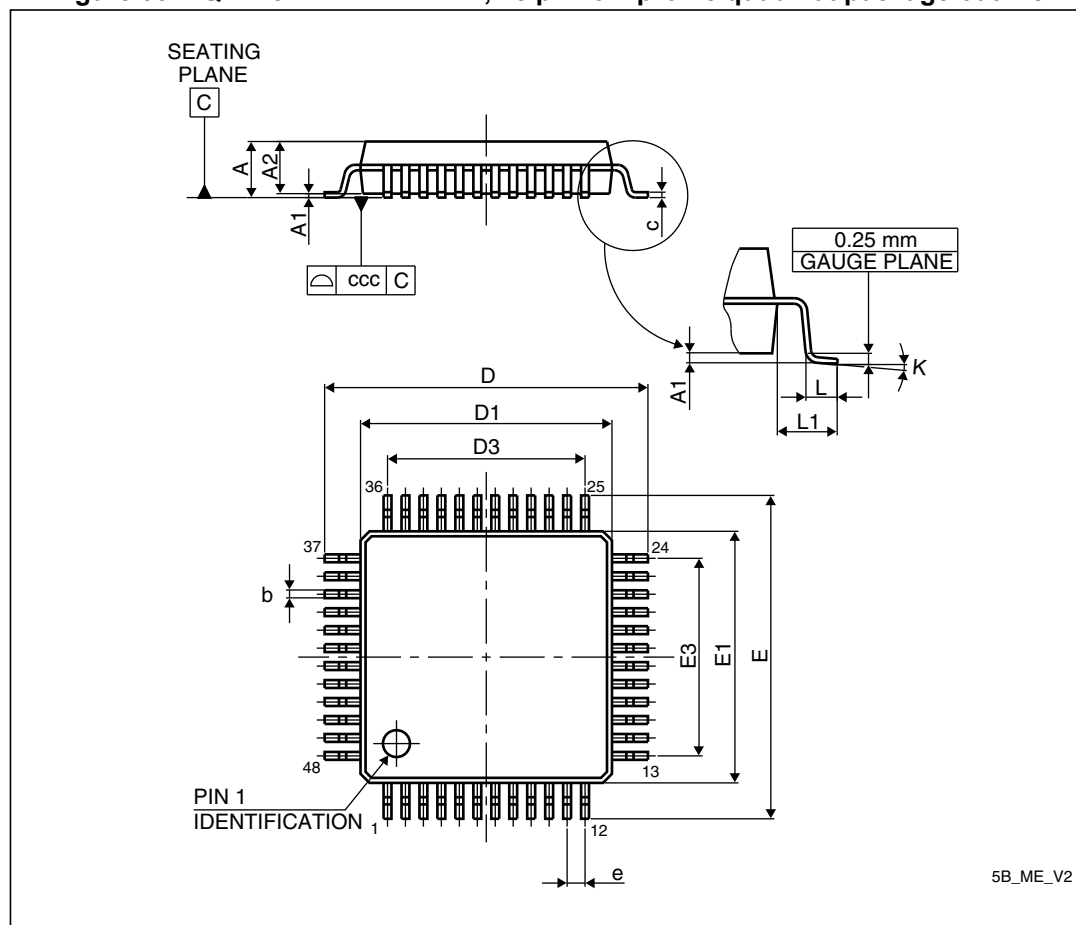

1. Drawing is not to scale.

Table 65. LQFP48 – 7 mm x 7 mm low-profile quad flat package mechanical data

Symbol	millimeters			inches <sup>(1)</sup>		
	Min	Typ	Max	Min	Typ	Max
A		-	1.600	-	-	0.0630
A1	0.050	-	0.150	0.0020	-	0.0059
A2	1.350	1.400	1.450	0.0531	0.0551	0.0571
b	0.170	0.220	0.270	0.0067	0.0087	0.0106

**Table 65. LQFP48 – 7 mm x 7 mm low-profile quad flat package mechanical data**

Symbol	millimeters			inches <sup>(1)</sup>		
	Min	Typ	Max	Min	Typ	Max
c	0.090	-	0.200	0.0035	-	0.0079
D	8.800	9.000	9.200	0.3465	0.3543	0.3622
D1	6.800	7.000	7.200	0.2677	0.2756	0.2835
D3	-	5.500	-	-	0.2165	-
E	8.800	9.000	9.200	0.3465	0.3543	0.3622
E1	6.800	7.000	7.200	0.2677	0.2756	0.2835
E3	-	5.500	-	-	0.2165	-
e	-	0.500	-	-	0.0197	-
L	0.450	0.600	0.750	0.0177	0.0236	0.0295
L1	-	1.000	-	-	0.0394	-
ccc	-	-	0.080	-	-	0.0031
K	0°	3.5°	7°	0°	3.5°	7°

1. Values in inches are converted from mm and rounded to 4 decimal digits.

**Figure 34. LQFP48 recommended footprint**

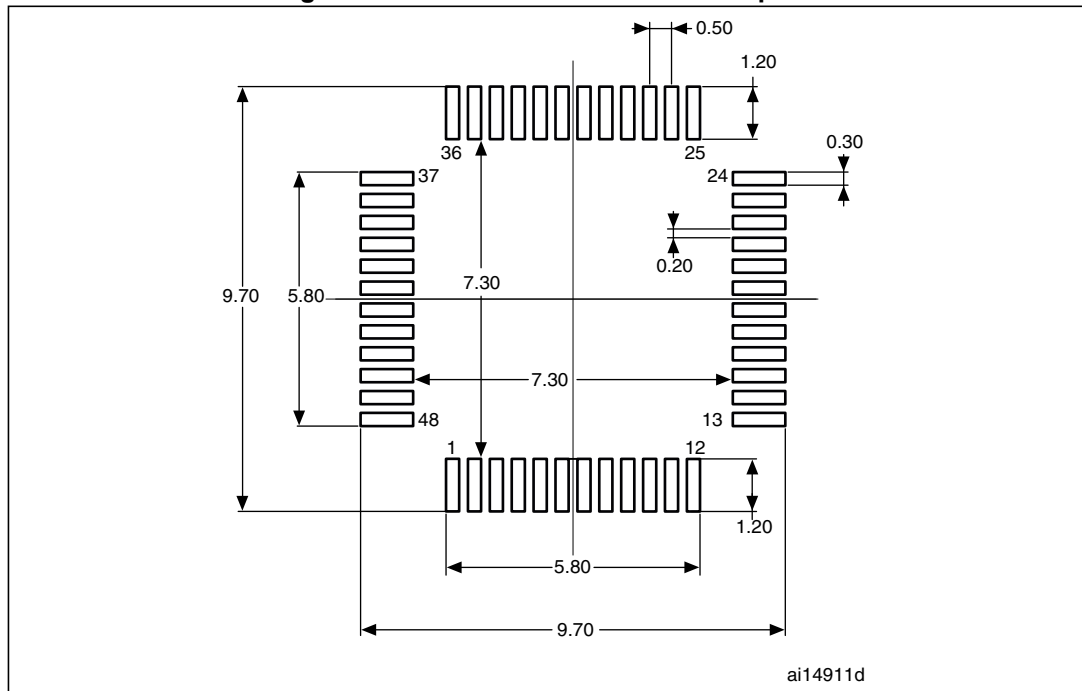

1. Dimensions are in millimeters.



**Marking of engineering samples for LQFP48**

The following figure shows the engineering sample marking for the LQFP48 package. Only the information field containing the engineering sample marking is shown.

**Figure 35. LQFP48 package top view**

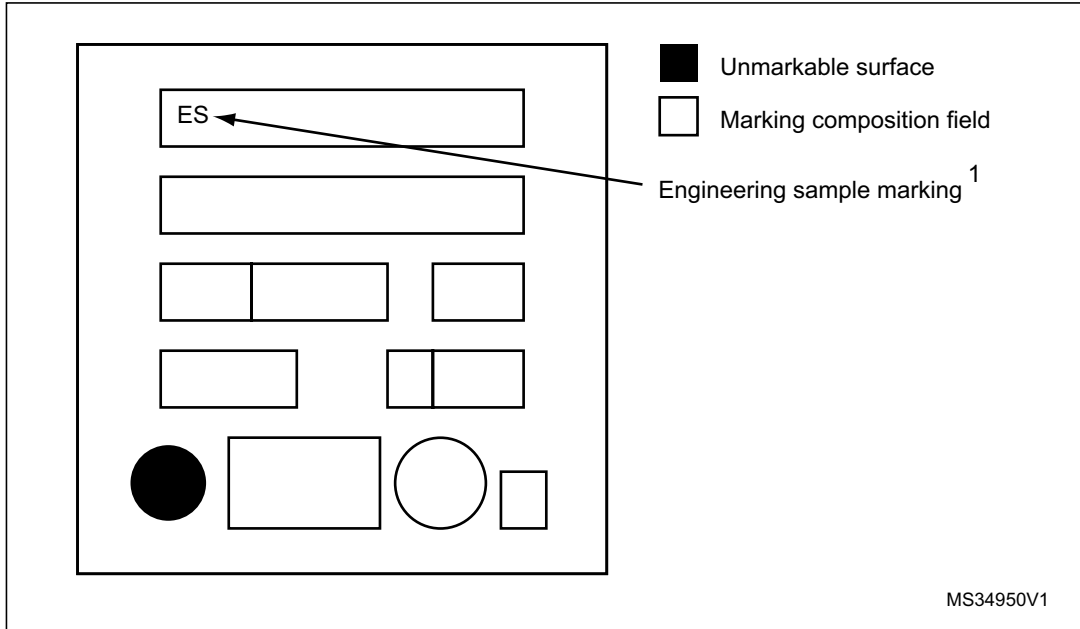

1. Samples marked "ES" are to be considered as "Engineering Samples": i.e. they are intended to be sent to customer for electrical compatibility evaluation and may be used to start customer qualification where specifically authorized by ST in writing. In no event ST will be liable for any customer usage in production. Only if ST has authorized in writing the customer qualification Engineering Samples can be used for reliability qualification trials.

Figure 36. UFQFPN48 – 7 mm x 7 mm, 0.5 mm pitch, package outline

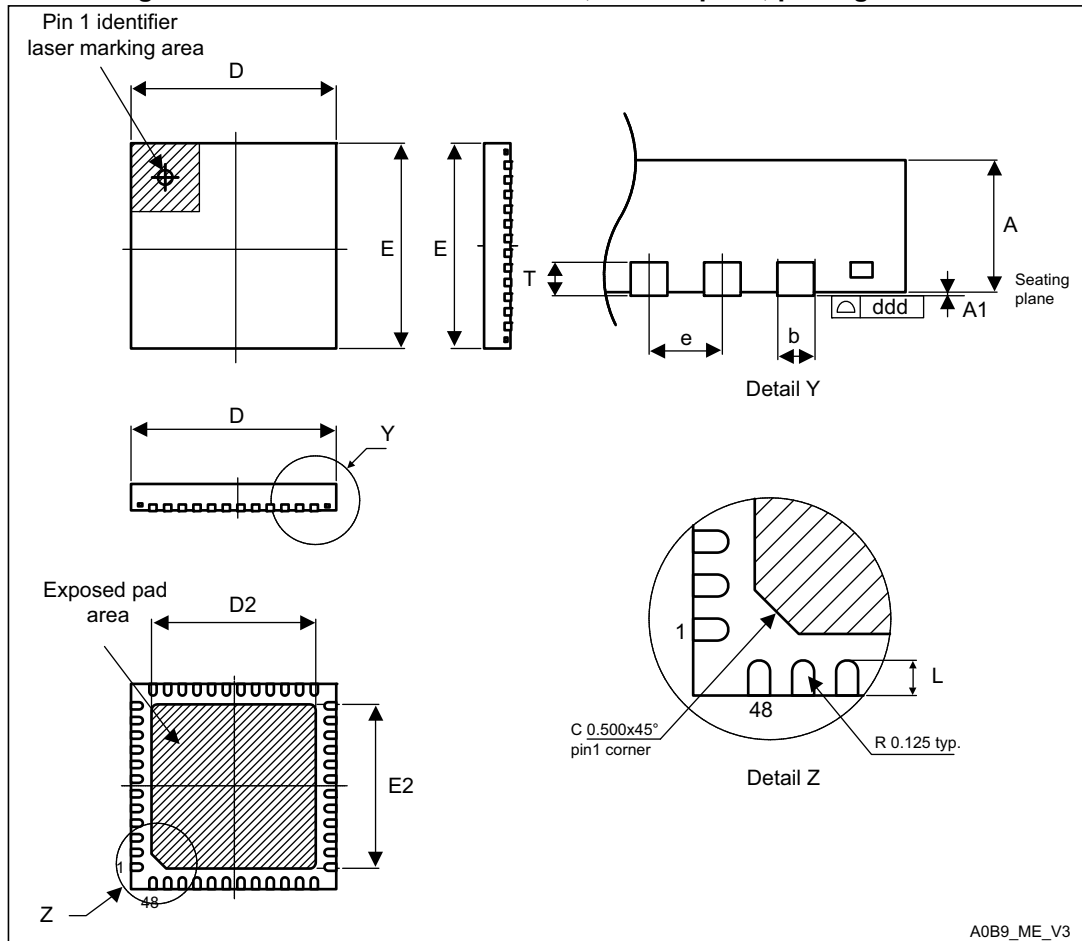

A0B9\_ME\_V3

1. Drawing is not to scale.
2. All leads/pads should also be soldered to the PCB to improve the lead/pad solder joint life.
3. There is an exposed die pad on the underside of the UFQFPN package. It is recommended to connect and solder this back-side pad to PCB ground.

Table 66. UFQFPN48 – 7 mm x 7 mm, 0.5 mm pitch, package mechanical data

Symbol	millimeters			inches <sup>(1)</sup>		
	Min	Typ	Max	Min	Typ	Max
A	0.500	0.550	0.600	0.0197	0.0217	0.0236
A1	0.000	0.020	0.050	0.0000	0.0008	0.0020
D	6.900	7.000	7.100	0.2717	0.2756	0.2795
E	6.900	7.000	7.100	0.2717	0.2756	0.2795
D2	5.500	5.600	5.700	0.2165	0.2205	0.2244
E2	5.500	5.600	5.700	0.2165	0.2205	0.2244
L	0.300	0.400	0.500	0.0118	0.0157	0.0197
T	-	0.152	-	-	0.0060	-
b	0.200	0.250	0.300	0.0079	0.0098	0.0118
e	-	0.500	-	-	0.0197	-

1. Values in inches are converted from mm and rounded to 4 decimal digits.

Figure 37. UFQFPN48 recommended footprint

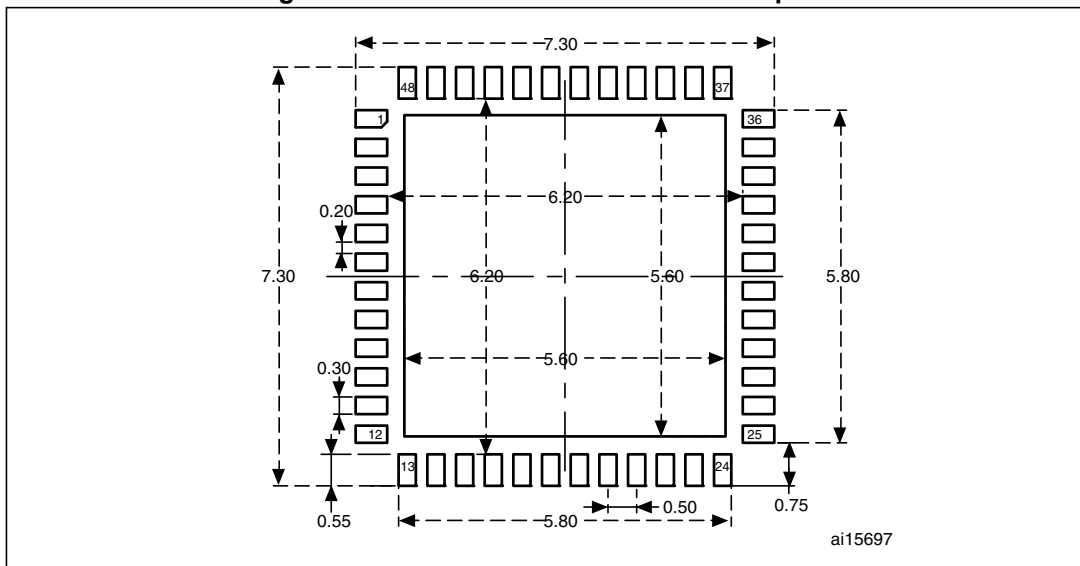

1. Dimensions are in millimeters.

**Marking of engineering samples for UFQFPN48**

The following figure shows the engineering sample marking for the UFQFPN48 package. Only the information field containing the engineering sample marking is shown.

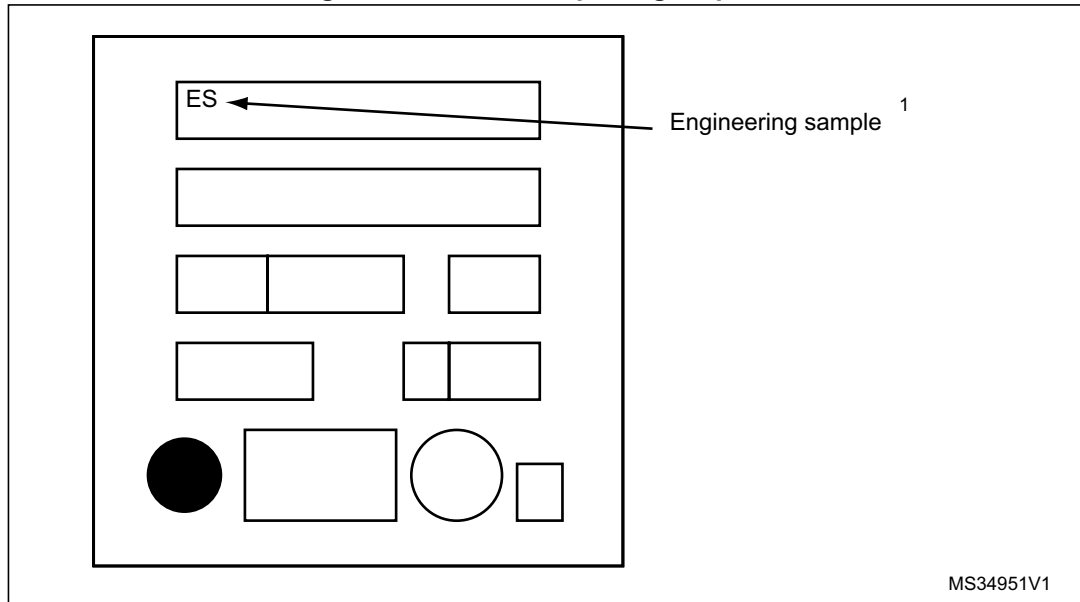
**Figure 38. UFQFPN48 package top view**

1. Samples marked "ES" are to be considered as "Engineering Samples": i.e. they are intended to be sent to customer for electrical compatibility evaluation and may be used to start customer qualification where specifically authorized by ST in writing. In no event ST will be liable for any customer usage in production. Only if ST has authorized in writing the customer qualification Engineering Samples can be used for reliability qualification trials.

Figure 39. WLCSP36 - 0.4 mm pitch, package outline

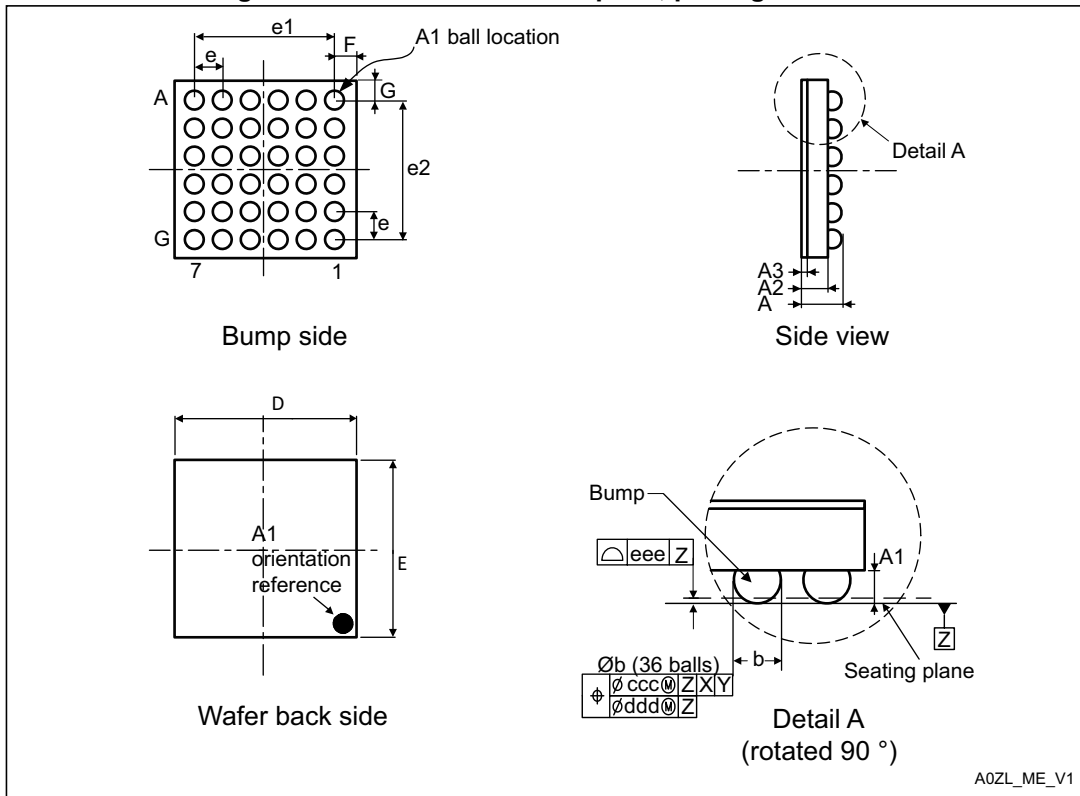

1. Drawing is not to scale.

Table 67. WLCSP36, 0.4 mm pitch, package mechanical data

Symbol	millimeters			inches <sup>(1)</sup>		
	Min	Typ	Max	Min	Typ	Max
A	0.555	0.525	0.585	0.0219	0.0207	0.0230
A1	0.175	-	-	0.0069	-	-
A2	0.380	-	-	0.0150	-	-
A3 <sup>(2)</sup>	0.025	-	-	0.0010	-	-
b <sup>(3)</sup>	0.250	0.220	0.280	0.0098	0.0087	0.0110
D	2.605	2.570	2.640	0.1026	0.1012	0.1039
E	2.703	2.668	2.738	0.1064	0.1050	0.1078
e	0.400	-	-	0.0157	-	-
e1	2.000	-	-	0.0787	-	-
e2	2.000	-	-	0.0787	-	-
F	0.3025	-	-	0.0119	-	-
G	0.2825	-	-	0.0111	-	-
ccc	0.100	-	-	0.0039	-	-
ddd	0.050	-	-	0.0020	-	-
eee	0.050	-	-	0.0020	-	-

1. Values in inches are converted from mm and rounded to 4 decimal digits.
2. Back side coating
3. Dimension is measured at the maximum bump diameter parallel to primary datum Z.

### Marking of engineering samples for WLCSP36

The following figure shows the engineering sample marking for the WLCSP36 package. Only the information field containing the engineering sample marking is shown.

Figure 40. WLCSP36 package top view

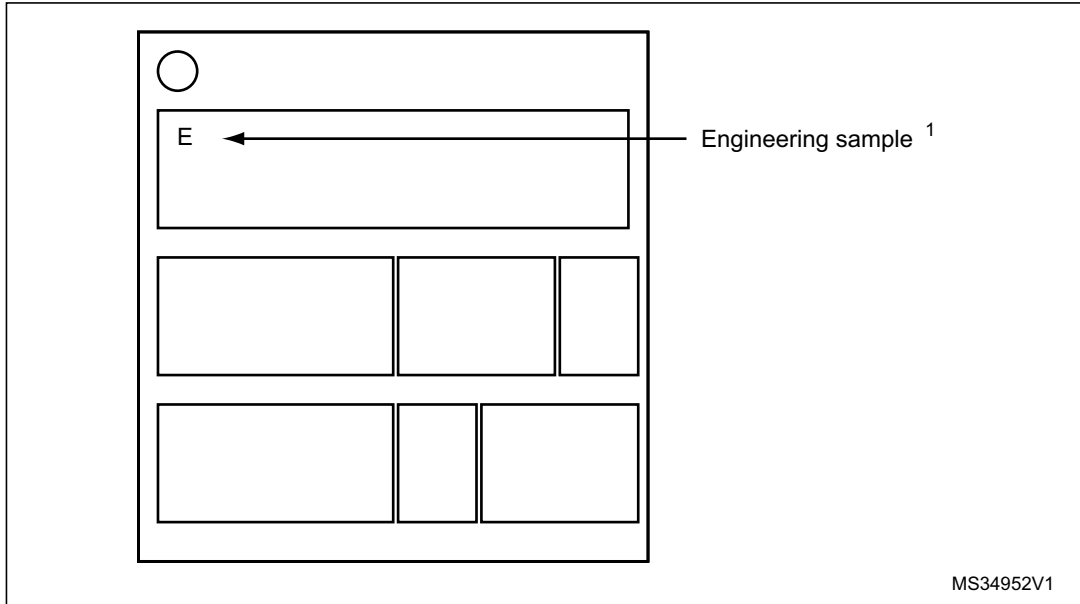

1. Samples marked "E" are to be considered as "Engineering Samples": i.e. they are intended to be sent to customer for electrical compatibility evaluation and may be used to start customer qualification where specifically authorized by ST in writing. In no event ST will be liable for any customer usage in production. Only if ST has authorized in writing the customer qualification Engineering Samples can be used for reliability qualification trials.

Figure 41. LQFP32 – 7 mm x 7 mm 32-pin low-profile quad flat package outline

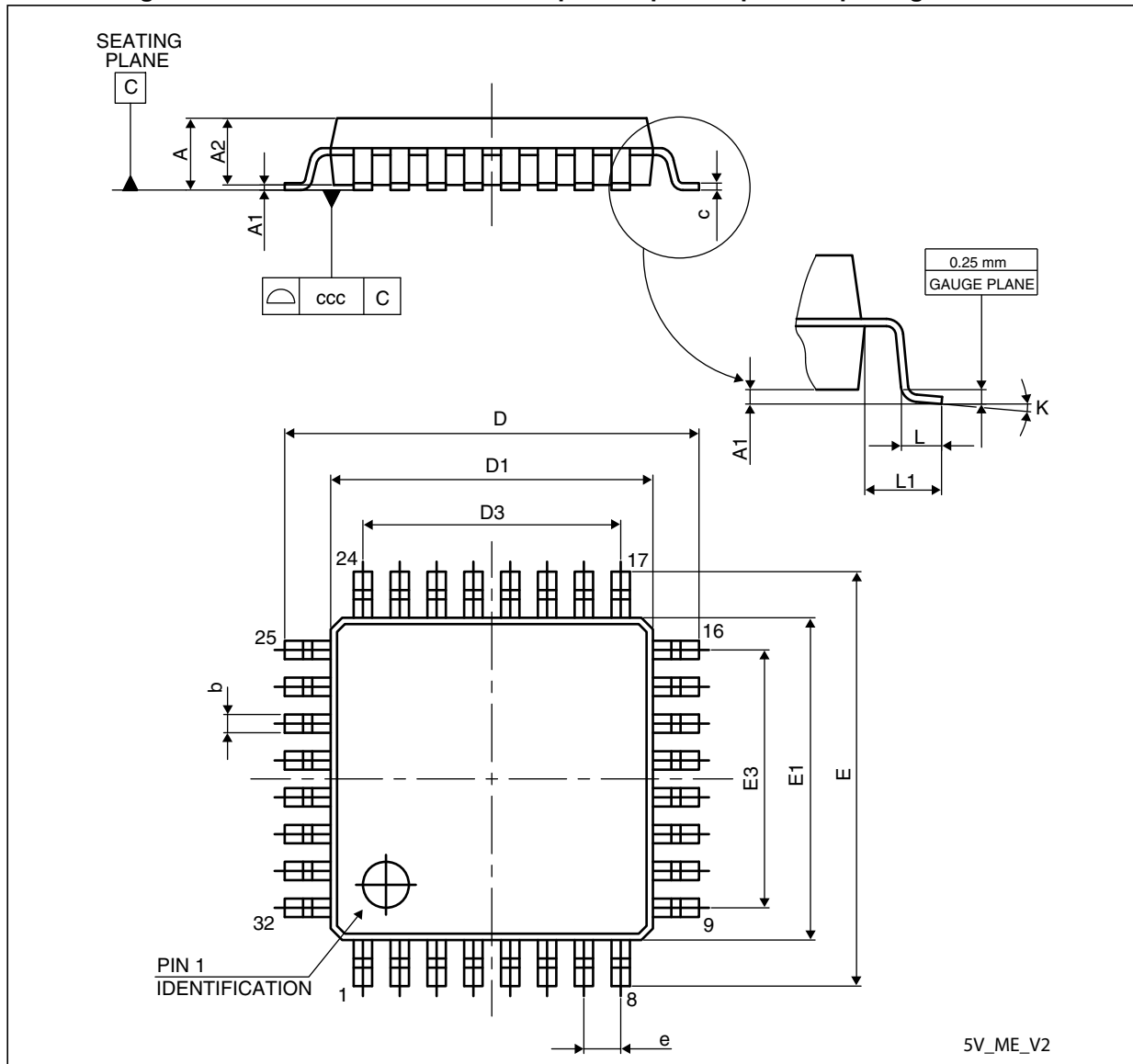

5V\_ME\_V2

1. Drawing is not to scale.

Table 68. LQFP32 – 7 mm x 7 mm 32-pin low-profile quad flat package mechanical data

Symbol	millimeters			inches <sup>(1)</sup>		
	Min	Typ	Max	Min	Typ	Max
A	-	-	1.600	-	-	0.0630
A1	0.050	-	0.150	0.0020	-	0.0059
A2	1.350	1.400	1.450	0.0531	0.0551	0.0571
b	0.300	0.370	0.450	0.0118	0.0146	0.0177
c	0.090	-	0.200	0.0035	-	0.0079
D	8.800	9.000	9.200	0.3465	0.3543	0.3622

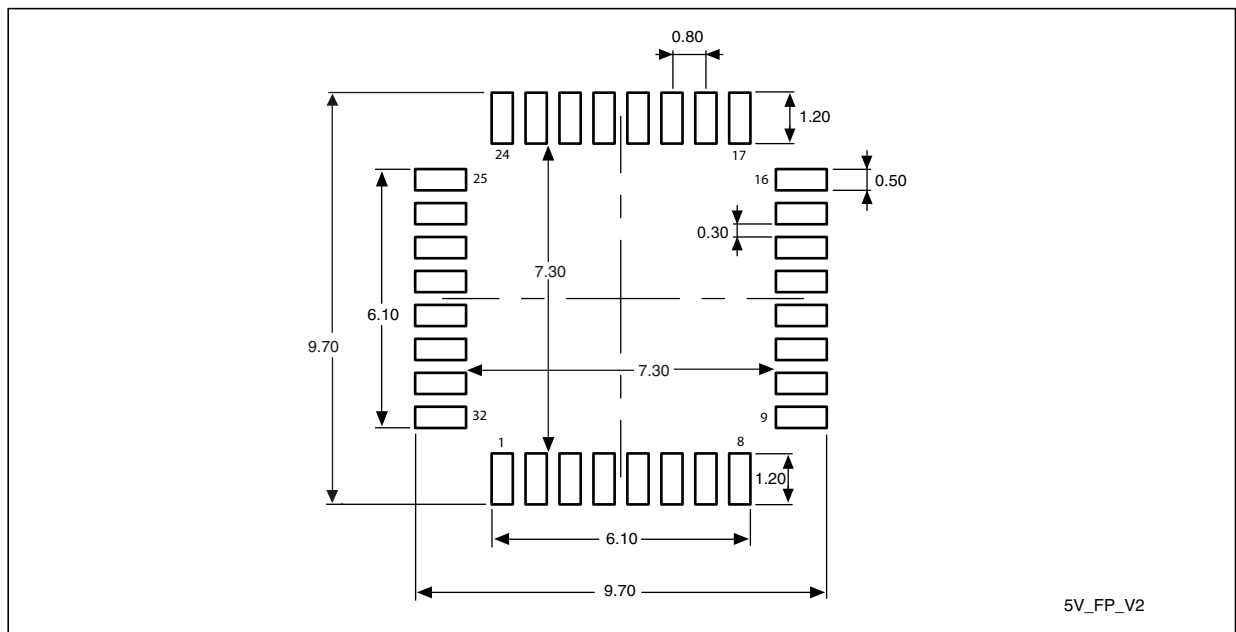

**Table 68. LQFP32 – 7 mm x 7 mm 32-pin low-profile quad flat package mechanical data**

Symbol	millimeters			inches <sup>(1)</sup>		
	Min	Typ	Max	Min	Typ	Max
D1	6.800	7.000	7.200	0.2677	0.2756	0.2835
D3	-	5.600	-	-	0.2205	-
E	8.800	9.000	9.200	0.3465	0.3543	0.3622
E1	6.800	7.000	7.200	0.2677	0.2756	0.2835
E3	-	5.600	-	-	0.2205	-
e	-	0.800	-	-	0.0315	-
L	0.450	0.600	0.750	0.0177	0.0236	0.0295
L1	-	1.000	-	-	0.0394	-
k	0.0°	3.5°	7.0°	0.0°	3.5°	7.0°
ccc	-	-	0.100	-	-	0.0039

1. Values in inches are converted from mm and rounded to 4 decimal digits.

**Figure 42. LQFP32 recommended footprint**



1. Drawing is not to scale.
2. Dimensions are in millimeters.

**Marking of engineering samples for LQFP32**

The following figure shows the engineering sample marking for the LQFP32 package. Only the information field containing the engineering sample marking is shown.

**Figure 43. LQFP32 package top view**

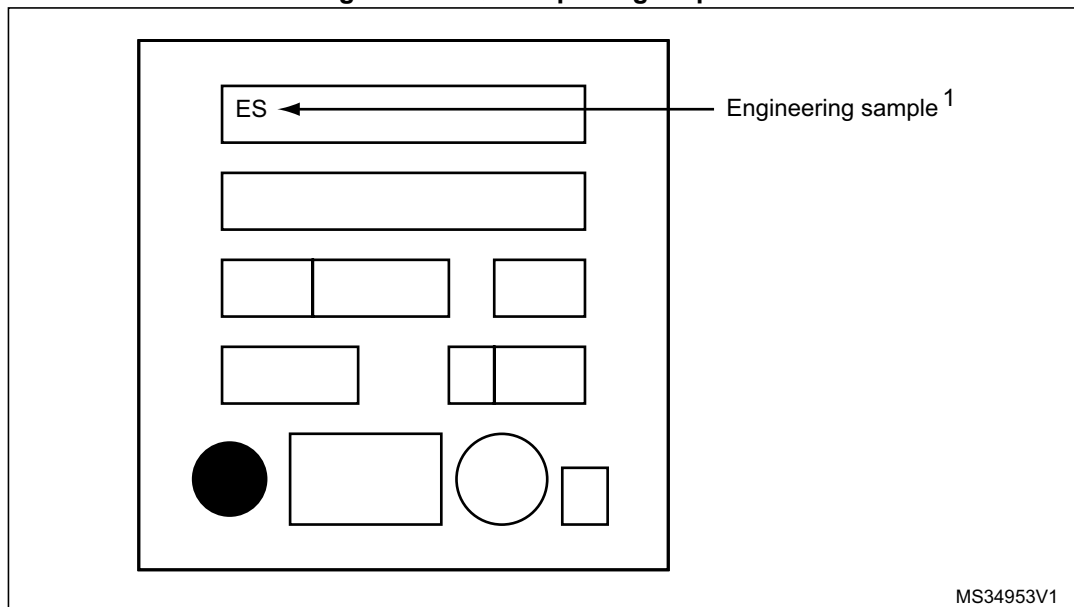

1. Samples marked "ES" are to be considered as "Engineering Samples": i.e. they are intended to be sent to customer for electrical compatibility evaluation and may be used to start customer qualification where specifically authorized by ST in writing. In no event ST will be liable for any customer usage in production. Only if ST has authorized in writing the customer qualification Engineering Samples can be used for reliability qualification trials.

Figure 44. UFQFPN32 - 5 x 5 mm, 32-lead ultra thin fine pitch quad flat no-lead package outline

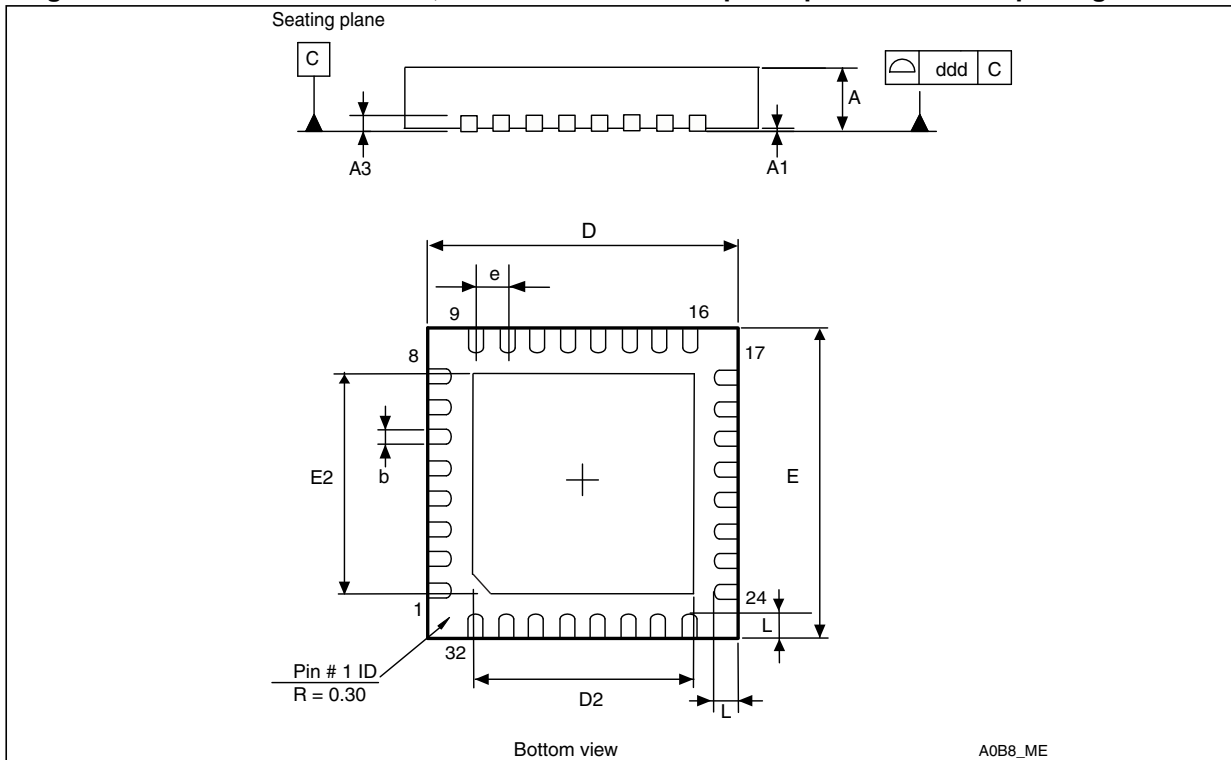

1. Drawing is not to scale.
2. All leads/pads should also be soldered to the PCB to improve the lead/pad solder joint life.
3. There is an exposed die pad on the underside of the UFQFPN package. This pad is used for the device ground and must be connected. It is referred to as pin 0 in [Table 12: Legend/abbreviations used in the pinout table](#).

Table 69. UFQFPN32 – 5 x 5 mm, 32-lead ultra thin fine pitch quad flat no-lead package mechanical data

Dim.	millimeters			inches <sup>(1)</sup>		
	Min	Typ	Max	Min	Typ	Max
A	0.5	0.55	0.6	0.0197	0.0217	0.0236
A1	0.00	0.02	0.05	0	0.0008	0.0020
A3	-	0.152	-	-	0.006	-
b	0.18	0.23	0.28	0.0071	0.0091	0.0110
D	4.90	5.00	5.10	0.1929	0.1969	0.2008
D2	-	3.50	-	-	0.1378	-
E	4.90	5.00	5.10	0.1929	0.1969	0.2008
E2	3.40	3.50	3.60	0.1339	0.1378	0.1417
e	-	0.500	-	-	0.0197	-
L	0.30	0.40	0.50	0.0118	0.0157	0.0197
ddd	0.08			0.0031		

1. Values in inches are converted from mm and rounded to 4 decimal digits.

Figure 45. UFQFPN32 recommended footprint

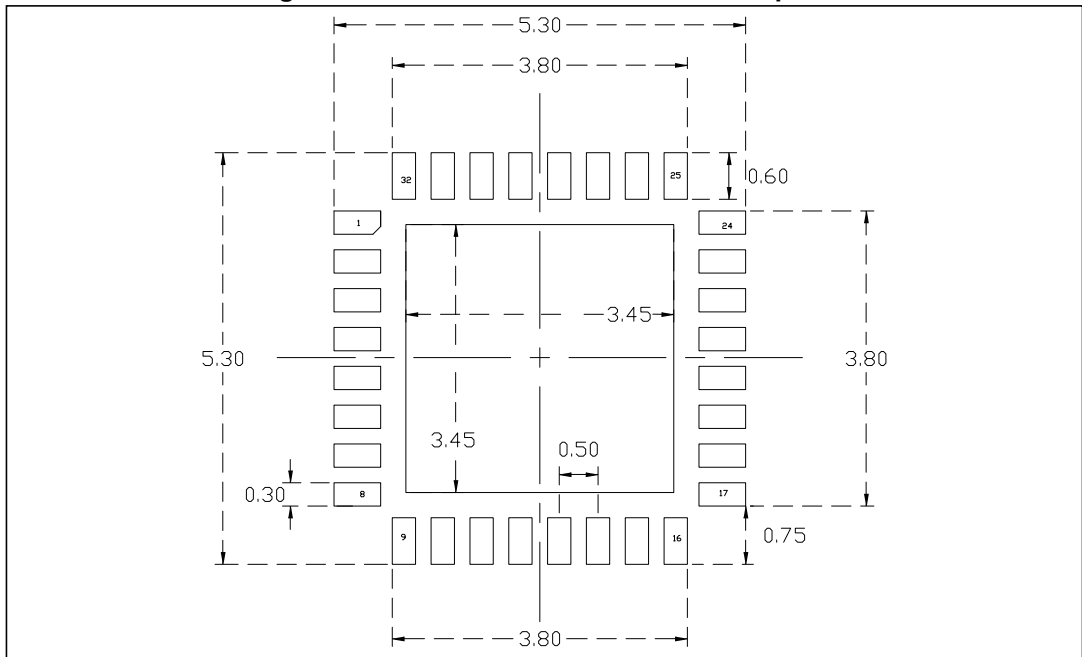

- 1. Drawing is not to scale.
- 2. Dimensions are in millimeters.

**Marking of engineering samples for UFQFPN32**

The following figure shows the engineering sample marking for the UFQFPN32 package. Only the information field containing the engineering sample marking is shown.

Figure 46. UFQFPN32 package top view

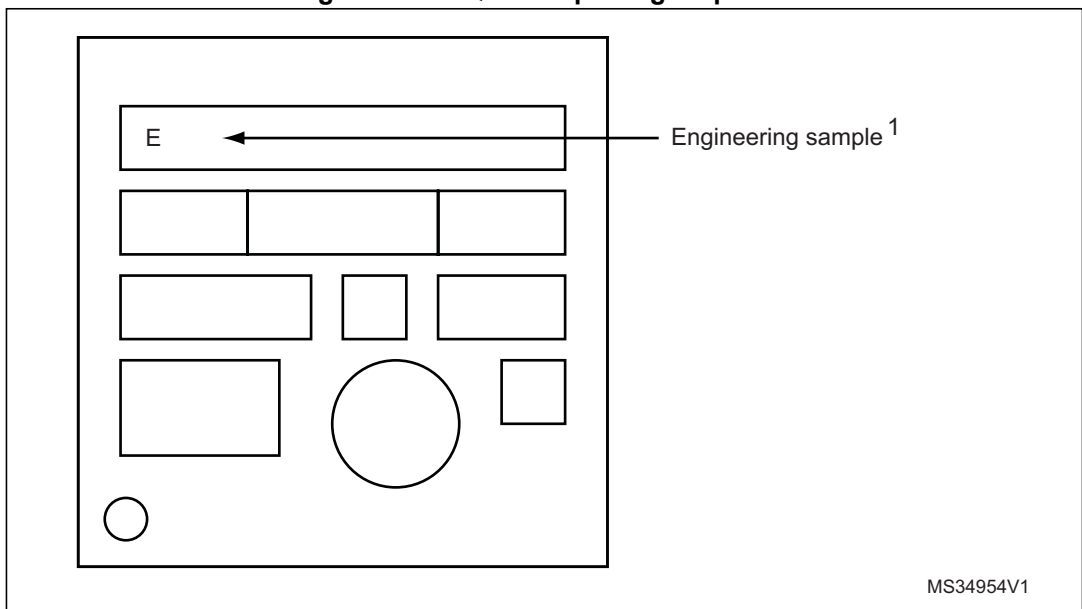

MS34954V1

- 1. Samples marked "E" are to be considered as "Engineering Samples": i.e. they are intended to be sent to customer for electrical compatibility evaluation and may be used to start customer qualification where specifically authorized by ST in writing. In no event ST will be liable for any customer usage in production. Only if ST has authorized in writing the customer qualification Engineering Samples can be used for reliability qualification trials.

Figure 47. UFQFPN28 - 4 x 4 mm, 28-lead ultra thin fine pitch quad flat no-lead package outline

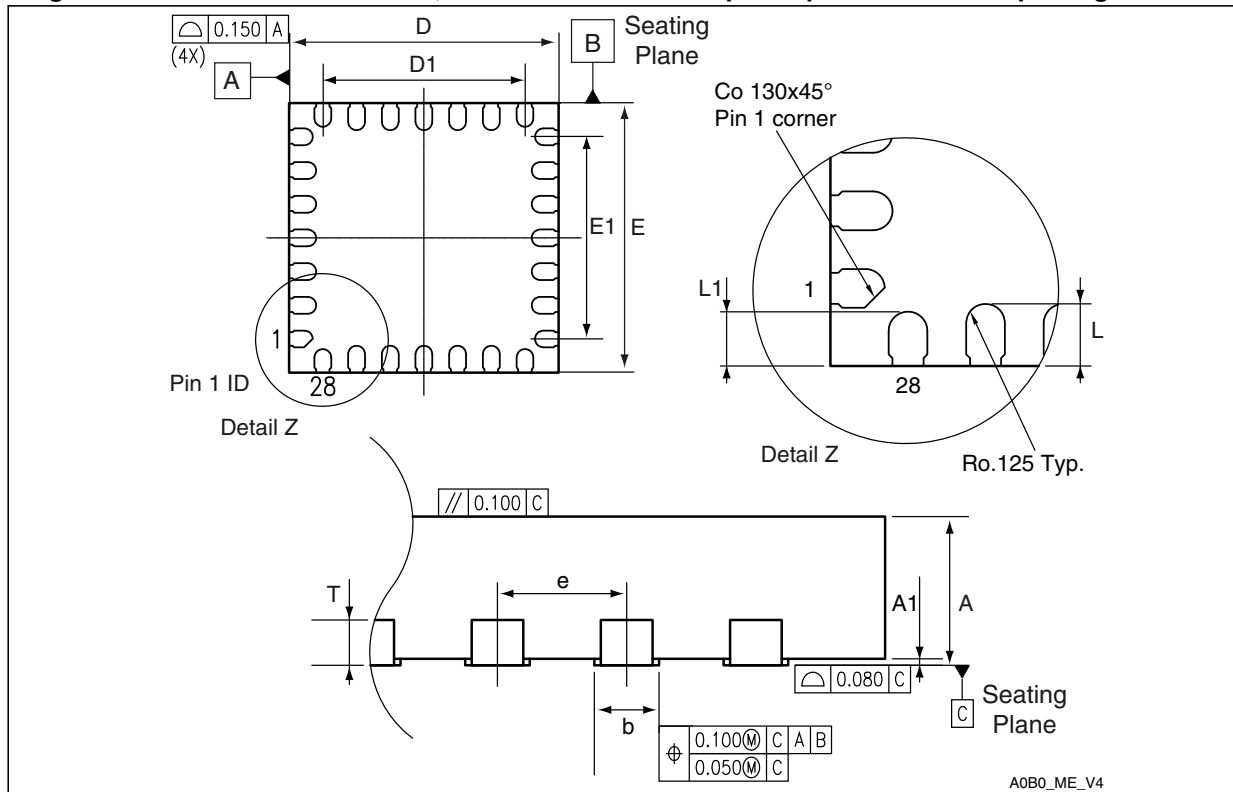

1. Drawing is not to scale.
2. Dimensions are in millimeters.
3. All leads/pads should also be soldered to the PCB to improve the lead/pad solder joint life.

Table 70. UFQFPN28 – 4 x 4 mm, 28-lead ultra thin fine pitch quad flat no-lead package mechanical data

Symbol	millimeters			inches <sup>(1)</sup>		
	Min	Typ	Max	Min	Typ	Max
A	0.5	0.55	0.6	0.0197	0.0217	0.0236
A1	-0.05	0	0.05	-0.002	0	0.002
D	3.9	4	4.1	0.1535	0.1575	0.1614
D1	2.9	3	3.1	0.1142	0.1181	0.122
E	3.9	4	4.1	0.1535	0.1575	0.1614
E1	2.9	3	3.1	0.1142	0.1181	0.122
L	0.3	0.4	0.5	0.0118	0.0157	0.0197
L1	0.25	0.35	0.45	0.0098	0.0138	0.0177
T	-	0.152	-	-	0.006	-
b	0.2	0.25	0.3	0.0079	0.0098	0.0118
e	-	0.5	-	-	0.0197	-

1. Values in inches are converted from mm and rounded to 4 decimal digits.

Figure 48. UFQFPN28 recommended footprint

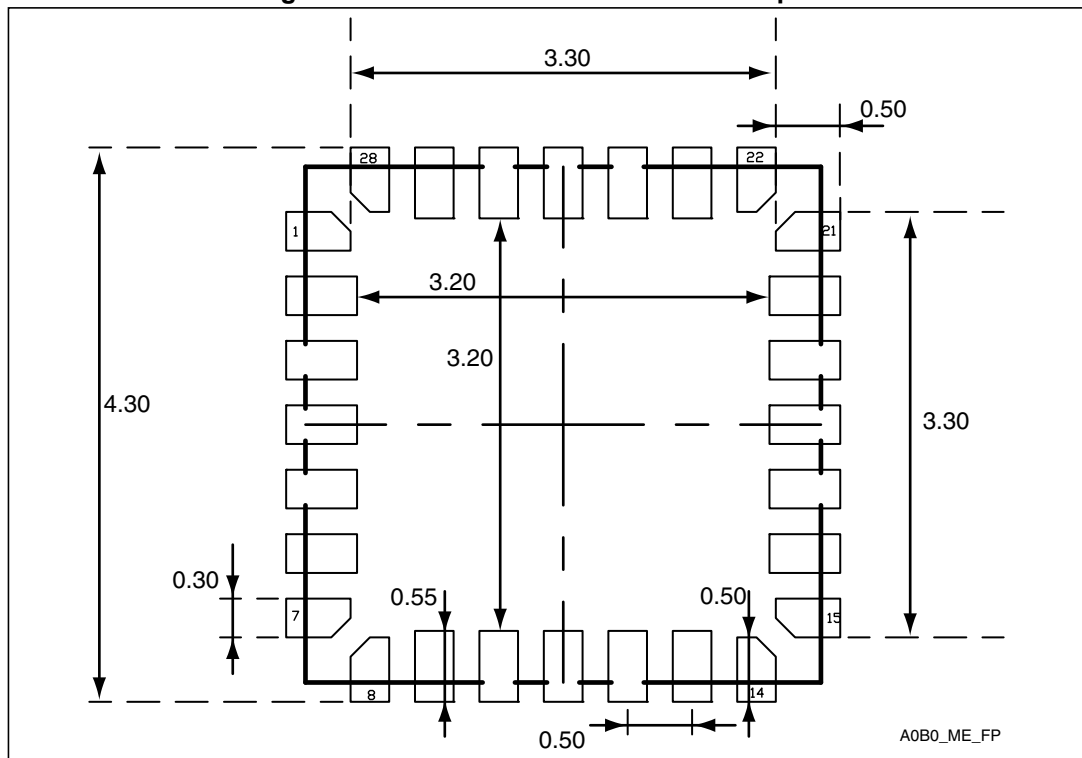

1. Dimensions are in millimeters
2. All leads/pads should also be soldered to the PCB to improve the lead/pad solder joint life.

### Marking of engineering samples for UFQFPN28

The following figure shows the engineering sample marking for the UFQFPN28 package. Only the information field containing the engineering sample marking is shown.

Figure 49. UFQFPN28 package top view

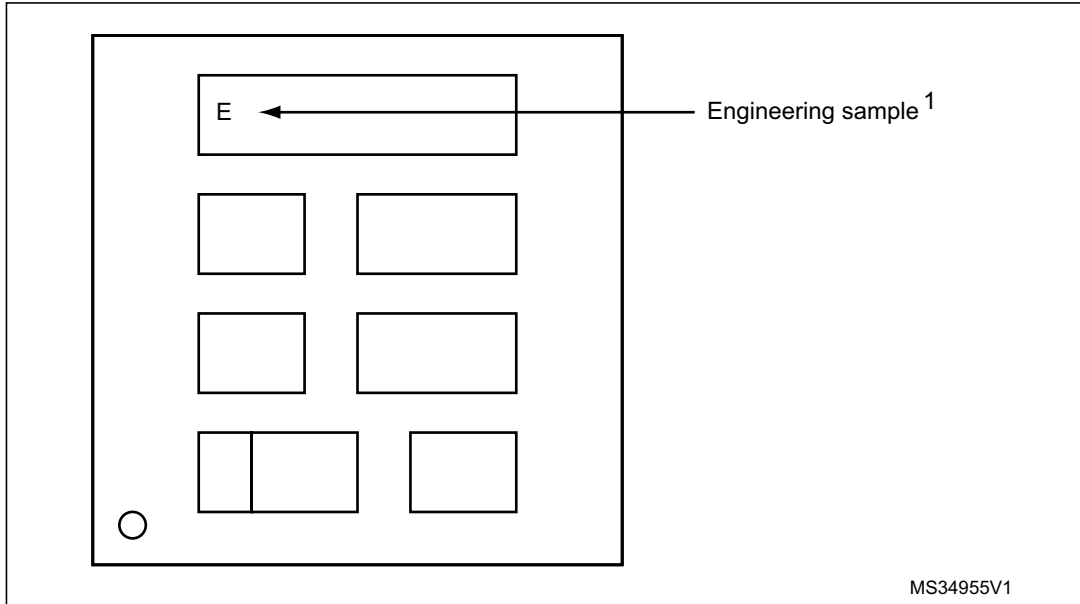

1. Samples marked "E" are to be considered as "Engineering Samples": i.e. they are intended to be sent to customer for electrical compatibility evaluation and may be used to start customer qualification where specifically authorized by ST in writing. In no event ST will be liable for any customer usage in production. Only if ST has authorized in writing the customer qualification Engineering Samples can be used for reliability qualification trials.

Figure 50. TSSOP20 - 20-pin thin shrink small outline

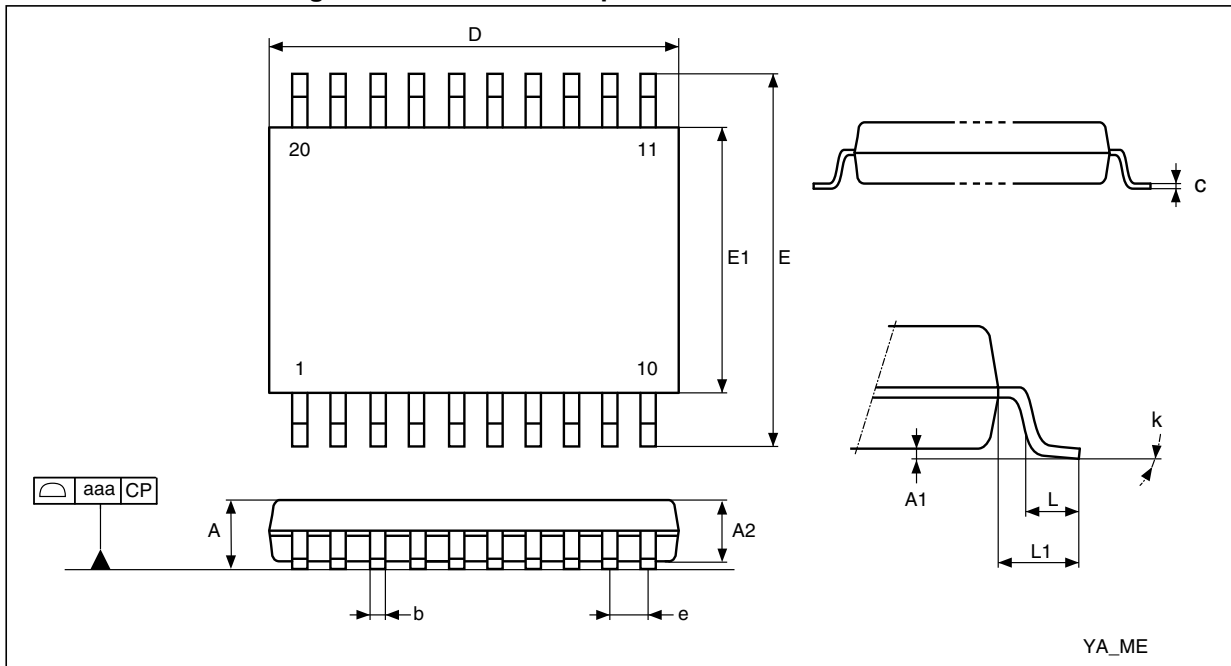

1. Drawing is not to scale.

Table 71. TSSOP20 – 20-pin thin shrink small outline package mechanical data

Symbol	millimeters			inches <sup>(1)</sup>		
	Min	Typ	Max	Min	Typ	
A		-	1.2	-	-	0.0472
A1	0.05	-	0.15	0.002	-	0.0059
A2	0.8	1	1.05	0.0315	0.0394	0.0413
b	0.19		0.3	0.0075	-	0.0118
c	0.09		0.2	0.0035	-	0.0079
D <sup>(2)</sup>	6.4	6.5	6.6	0.252	0.2559	0.2598
E	6.2	6.4	6.6	0.2441	0.252	0.2598
E1 <sup>(3)</sup>	4.3	4.4	4.5	0.1693	0.1732	0.1772
e	-	0.65	-	-	0.0256	-
L	0.45	0.6	0.75	0.0177	0.0236	0.0295
L1	-	1	-	-	0.0394	-
k	0.0°	-	8.0°	0.0°	-	8.0°
aaa	-	-	0.1	-	-	0.0039

1. Values in inches are converted from mm and rounded to 4 decimal digits.

2. Dimension “D” does not include mold flash, protrusions or gate burrs. Mold flash, protrusions or gate burrs shall not exceed 0.15mm per side.

3. Dimension “E1” does not include interlead flash or protrusions. Interlead flash or protrusions shall not exceed 0.25mm per side.



Figure 51. TSSOP20 recommended footprint

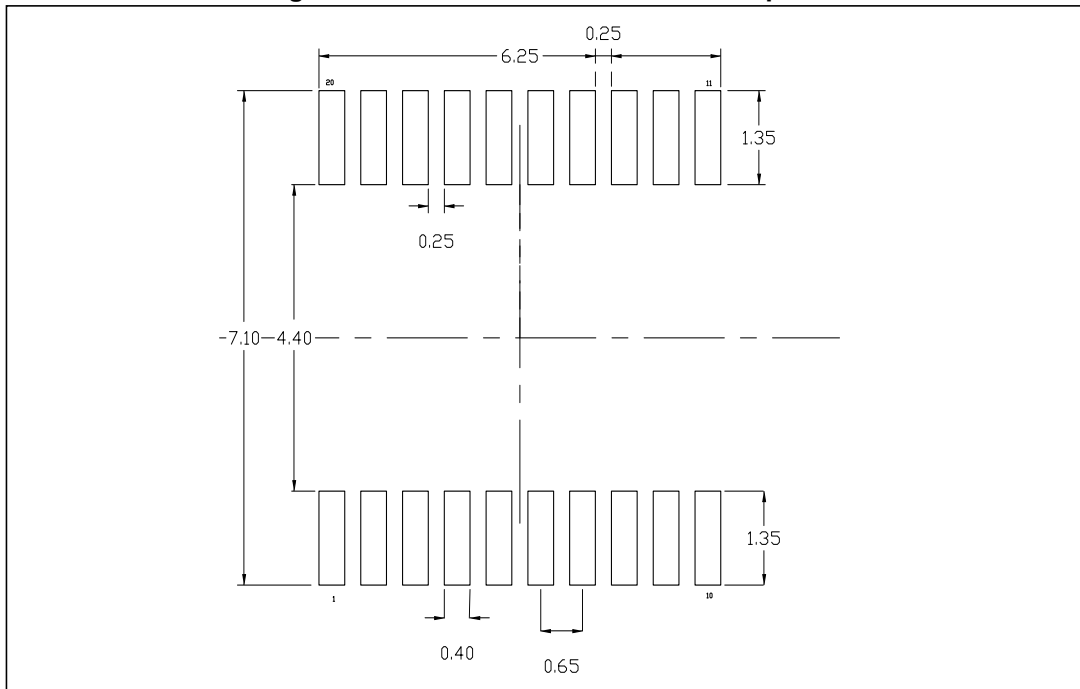

1. Dimensions are in millimeters.

**Marking of engineering samples for TSSOP20**

The following figure shows the engineering sample marking for the TSSOP20 package. Only the information field containing the engineering sample marking is shown.

Figure 52. TSSOP20 package top view

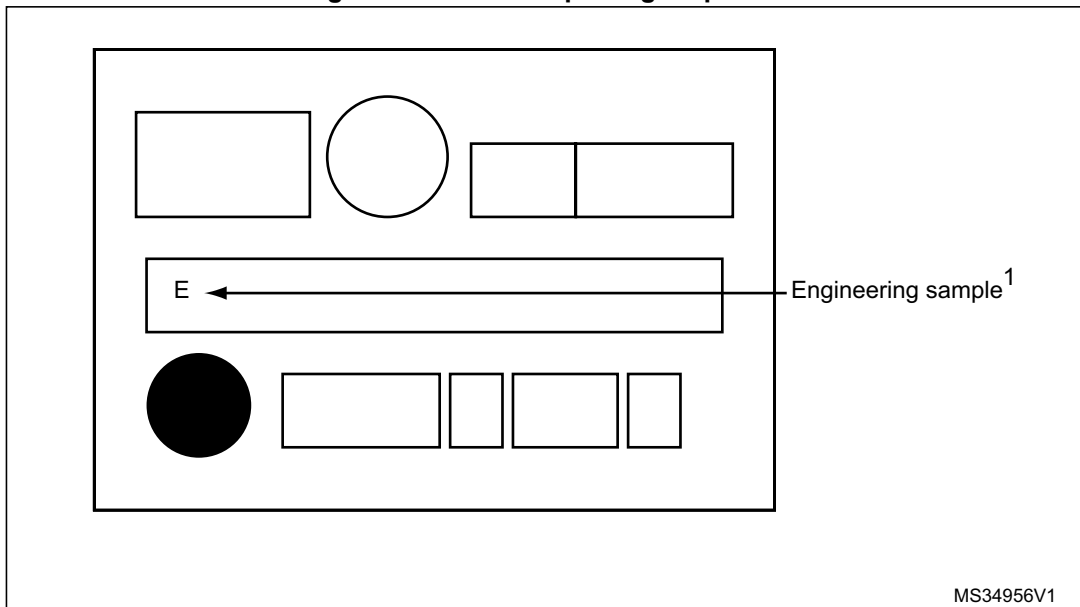

1. Samples marked "E" are to be considered as "Engineering Samples": i.e. they are intended to be sent to customer for electrical compatibility evaluation and may be used to start customer qualification where specifically authorized by ST in writing. In no event ST will be liable for any customer usage in production. Only if ST has authorized in writing the customer qualification Engineering Samples can be used for reliability qualification trials.

## 7.2 Thermal characteristics

The maximum chip junction temperature ( $T_{Jmax}$ ) must never exceed the values given in [Table 21: General operating conditions](#).

The maximum chip-junction temperature,  $T_J$  max, in degrees Celsius, may be calculated using the following equation:

$$T_J \text{ max} = T_A \text{ max} + (P_D \text{ max} \times \Theta_{JA})$$

Where:

- $T_A$  max is the maximum ambient temperature in °C,
- $\Theta_{JA}$  is the package junction-to-ambient thermal resistance, in °C/W,
- $P_D$  max is the sum of  $P_{INT}$  max and  $P_{I/O}$  max ( $P_D$  max =  $P_{INT}$  max +  $P_{I/O}$ max),
- $P_{INT}$  max is the product of  $I_{DD}$  and  $V_{DD}$ , expressed in Watts. This is the maximum chip internal power.

$P_{I/O}$  max represents the maximum power dissipation on output pins where:

$$P_{I/O} \text{ max} = \Sigma (V_{OL} \times I_{OL}) + \Sigma ((V_{DD} - V_{OH}) \times I_{OH}),$$

taking into account the actual  $V_{OL} / I_{OL}$  and  $V_{OH} / I_{OH}$  of the I/Os at low and high level in the application.

**Table 72. Package thermal characteristics**

Symbol	Parameter	Value	Unit
$\Theta_{JA}$	<b>Thermal resistance junction-ambient</b> LQFP48 - 7 mm x 7 mm	55	°C/W
	<b>Thermal resistance junction-ambient</b> UFQFPN48 - 7 mm x 7 mm	33	
	<b>Thermal resistance junction-ambient</b> WLCSP36 die 445	64	
	<b>Thermal resistance junction-ambient</b> LQFP32 - 7 mm x 7 mm	57	
	<b>Thermal resistance junction-ambient</b> UFQFPN32 - 5 mm x 5 mm	38	
	<b>Thermal resistance junction-ambient</b> UFQFPN28 - 4 mm x 4 mm	118	
	<b>Thermal resistance junction-ambient</b> TSSOP20 - 6.5 mm x 6.4 mm	76	

### 7.2.1 Reference document

JESD51-2 Integrated Circuits Thermal Test Method Environment Conditions - Natural Convection (Still Air). Available from [www.jedec.org](http://www.jedec.org)

## 8 Part numbering

For a list of available options (memory, package, and so on) or for further information on any aspect of this device, please contact your nearest ST sales office.

**Table 73. Ordering information scheme**

Example:	STM32	F	042	C	6	T	6	x
<b>Device family</b> STM32 = ARM-based 32-bit microcontroller								
<b>Product type</b> F = General-purpose								
<b>Sub-family</b> 042 = STM32F042xx								
<b>Pin count</b> F = 20 pins G = 28 pins K = 32 pins T = 36 pins C = 48 pins								
<b>Code size</b> 4 = 16 Kbytes of Flash memory 6 = 32 Kbytes of Flash memory								
<b>Package</b> P = TSSOP T = LQFP U = UFQFPN Y = WLCSP								
<b>Temperature range</b> 6 = -40 to 85 °C 7 = -40 to 105 °C								
<b>Options</b> xxx = programmed parts TR = tape and reel								

## 9 Revision history

**Table 74. Document revision history**

Date	Revision	Changes
25-Feb-2014	1	Initial release.
04-Apr-2014	2	<p>Updated:</p> <ul style="list-style-type: none"> <li>– The document status to Datasheet - production data,</li> <li>– <i>Table 10: STM32F042x USART implementation</i>: added one table footnote.</li> <li>– <i>Figure 3: LQFP48 48-pin package pinout (top view)</i>,</li> <li>– <i>Figure 8: UQFPN28 28-pin package (top view)</i>,</li> <li>– <i>Table 13: STM32F042x pin definitions</i>,</li> <li>– <i>Table 19: Current characteristics</i>,</li> <li>– <i>Table 26: Typical and maximum current consumption from VDD supply at VDD = 3.6 V</i>,</li> <li>– <i>Table 27: Typical and maximum current consumption from the VDDA supply</i>,</li> <li>– <i>Table 28: Typical and maximum consumption in Stop and Standby modes</i>,</li> <li>– <i>Table 29: Typical and maximum current consumption from the VBAT supply</i>,</li> <li>– <i>Table 30: Typical current consumption, code executing from Flash, running from HSE 8 MHz crystal</i>,</li> <li>– <i>Table 43: Flash memory characteristics</i>,</li> <li>– <i>Table 45: EMS characteristics</i>,</li> <li>– <i>Table 46: EMI characteristics</i>,</li> <li>– <i>Table 50: I/O static characteristics</i>,</li> <li>– <i>Table 49: I/O current injection susceptibility</i>,</li> <li>– <i>Figure 13: Power supply scheme</i>,</li> <li>– <i>Figure 22: TC and TTA I/O input characteristics</i>,</li> <li>– <i>Figure 23: Five volt tolerant (FT and FTf) I/O input characteristics</i>.</li> </ul> <p>Added the sample engineering sections for all the packages in <i>Chapter 7: Package characteristics</i>:</p> <ul style="list-style-type: none"> <li>– <i>Figure 35: LQFP48 package top view</i>,</li> <li>– <i>Figure 38: UFQFPN48 package top view</i>,</li> <li>– <i>Figure 40: WLCSP36 package top view</i>,</li> <li>– <i>Figure 43: LQFP32 package top view</i>,</li> <li>– <i>Figure 46: UFQFPN32 package top view</i>,</li> <li>– <i>Figure 49: UFQFPN28 package top view</i>,</li> <li>– <i>Figure 52: TSSOP20 package top view</i>.</li> </ul>

**Please Read Carefully:**

Information in this document is provided solely in connection with ST products. STMicroelectronics NV and its subsidiaries ("ST") reserve the right to make changes, corrections, modifications or improvements, to this document, and the products and services described herein at any time, without notice.

All ST products are sold pursuant to ST's terms and conditions of sale.

Purchasers are solely responsible for the choice, selection and use of the ST products and services described herein, and ST assumes no liability whatsoever relating to the choice, selection or use of the ST products and services described herein.

No license, express or implied, by estoppel or otherwise, to any intellectual property rights is granted under this document. If any part of this document refers to any third party products or services it shall not be deemed a license grant by ST for the use of such third party products or services, or any intellectual property contained therein or considered as a warranty covering the use in any manner whatsoever of such third party products or services or any intellectual property contained therein.

**UNLESS OTHERWISE SET FORTH IN ST'S TERMS AND CONDITIONS OF SALE ST DISCLAIMS ANY EXPRESS OR IMPLIED WARRANTY WITH RESPECT TO THE USE AND/OR SALE OF ST PRODUCTS INCLUDING WITHOUT LIMITATION IMPLIED WARRANTIES OF MERCHANTABILITY, FITNESS FOR A PARTICULAR PURPOSE (AND THEIR EQUIVALENTS UNDER THE LAWS OF ANY JURISDICTION), OR INFRINGEMENT OF ANY PATENT, COPYRIGHT OR OTHER INTELLECTUAL PROPERTY RIGHT.**

**ST PRODUCTS ARE NOT DESIGNED OR AUTHORIZED FOR USE IN: (A) SAFETY CRITICAL APPLICATIONS SUCH AS LIFE SUPPORTING, ACTIVE IMPLANTED DEVICES OR SYSTEMS WITH PRODUCT FUNCTIONAL SAFETY REQUIREMENTS; (B) AERONAUTIC APPLICATIONS; (C) AUTOMOTIVE APPLICATIONS OR ENVIRONMENTS, AND/OR (D) AEROSPACE APPLICATIONS OR ENVIRONMENTS. WHERE ST PRODUCTS ARE NOT DESIGNED FOR SUCH USE, THE PURCHASER SHALL USE PRODUCTS AT PURCHASER'S SOLE RISK, EVEN IF ST HAS BEEN INFORMED IN WRITING OF SUCH USAGE, UNLESS A PRODUCT IS EXPRESSLY DESIGNATED BY ST AS BEING INTENDED FOR "AUTOMOTIVE, AUTOMOTIVE SAFETY OR MEDICAL" INDUSTRY DOMAINS ACCORDING TO ST PRODUCT DESIGN SPECIFICATIONS. PRODUCTS FORMALLY ESCC, QML OR JAN QUALIFIED ARE DEEMED SUITABLE FOR USE IN AEROSPACE BY THE CORRESPONDING GOVERNMENTAL AGENCY.**

Resale of ST products with provisions different from the statements and/or technical features set forth in this document shall immediately void any warranty granted by ST for the ST product or service described herein and shall not create or extend in any manner whatsoever, any liability of ST.

ST and the ST logo are trademarks or registered trademarks of ST in various countries.

Information in this document supersedes and replaces all information previously supplied.

The ST logo is a registered trademark of STMicroelectronics. All other names are the property of their respective owners.

© 2014 STMicroelectronics - All rights reserved

STMicroelectronics group of companies

Australia - Belgium - Brazil - Canada - China - Czech Republic - Finland - France - Germany - Hong Kong - India - Israel - Italy - Japan - Malaysia - Malta - Morocco - Philippines - Singapore - Spain - Sweden - Switzerland - United Kingdom - United States of America

[www.st.com](http://www.st.com)

