

# TC4027BP, TC4027BF, TC4027BFN

## TC4027B Dual J-K Master-Slave Flip Flop

TC4027B is J-K master-slave flip-flop having RESET and SET functions.

In the case of J-K made, when the clock input is given with both RESET and SET at "L", the output changes at rising edge of the clock according to the states of J and K.

When SET input is placed at "H", and RESET input is placed at "L", outputs become Q = "H", and  $\bar{Q}$  = "L".

When RESET input is placed at "H", and SET input is placed at "L", outputs become Q = "L", and  $\bar{Q}$  = "H".

When both of RESET input and SET input are at "H", outputs become Q = "H" and  $\bar{Q}$  = "H".

Note: xxxFN (JEDEC SOP) is not available in Japan.

### Pin Assignment

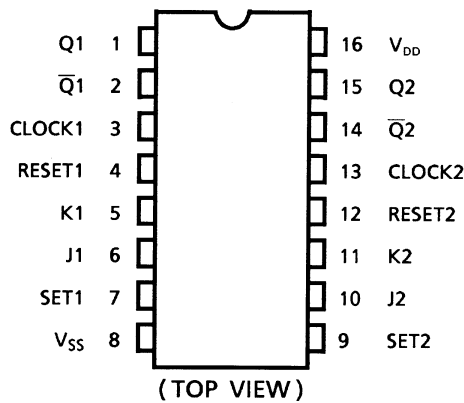

### Block Diagram

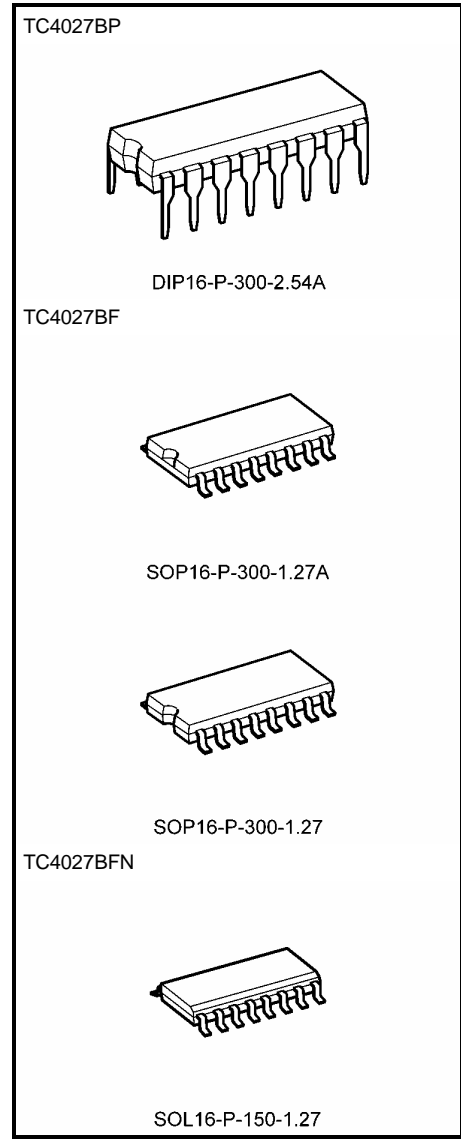
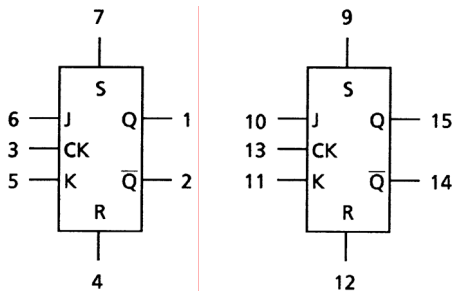

Weight	
DIP16-P-300-2.54A	: 1.00 g (typ.)
SOP16-P-300-1.27A	: 0.18 g (typ.)
SOP16-P-300-1.27	: 0.18 g (typ.)
SOL16-P-150-1.27	: 0.13 g (typ.)

## Truth Table

Inputs					Outputs	
RESET	SET	J	K	CLOCK $\Delta$	$Q_{n+1}$	$\bar{Q}_{n+1}$
L	H	*	*	*	H	L
H	L	*	*	*	L	H
H	H	*	*	*	H	H
L	L	L	L	$\uparrow$	$Q_n^*$	$Q_n^*$
L	L	L	H	$\uparrow$	L	H
L	L	H	L	$\uparrow$	H	L
L	L	H	H	$\uparrow$	$\bar{Q}_n^{**}$	$Q_n^{**}$
L	L	*	*	$\downarrow$	$Q_n^*$	$\bar{Q}_n^*$

\*: Don't care

$\Delta$ : Level change

\*: No change

\*\* : Change

## Logic Diagram

### 1/2 TC4027B

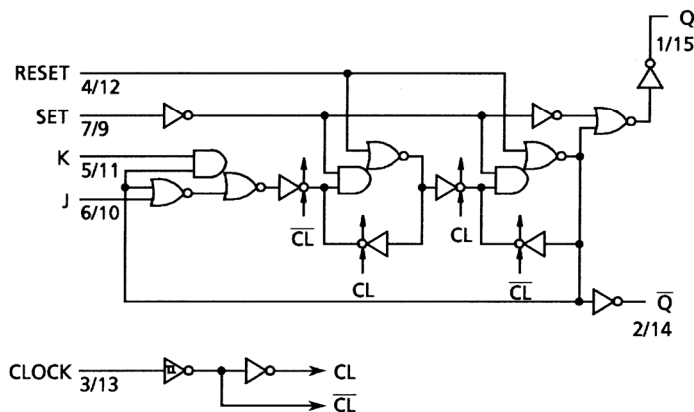

## Absolute Maximum Ratings (Note)

Characteristics	Symbol	Rating	Unit
DC supply voltage	$V_{DD}$	$V_{SS} - 0.5$ to $V_{SS} + 20$	V
Input voltage	$V_{IN}$	$V_{SS} - 0.5$ to $V_{DD} + 0.5$	V
Output voltage	$V_{OUT}$	$V_{SS} - 0.5$ to $V_{DD} + 0.5$	V
DC input current	$I_{IN}$	$\pm 10$	mA
Power dissipation	$P_D$	300 (DIP)/180 (SOIC)	mW
Operating temperature range	$T_{opr}$	-40 to 85	$^{\circ}C$
Storage temperature range	$T_{stg}$	-65 to 150	$^{\circ}C$

Note: Exceeding any of the absolute maximum ratings, even briefly, lead to deterioration in IC performance or even destruction.

## Recommended Operating Conditions ( $V_{SS} = 0\text{ V}$ ) (Note)

Characteristics	Symbol	Test Condition	Min	Typ.	Max	Unit
DC supply voltage	$V_{DD}$	—	3	—	18	V
Input voltage	$V_{IN}$	—	0	—	$V_{DD}$	V

Note: The recommended operating conditions are required to ensure the normal operation of the device.  
Unused inputs must be tied to either VCC or GND.

## Static Electrical Characteristics ( $V_{SS} = 0\text{ V}$ )

Characteristics	Sym- bol	Test Condition	$V_{DD}$ (V)	-40°C		25°C			85°C		Unit	
				Min	Max	Min	Typ.	Max	Min	Max		
High-level output voltage	$V_{OH}$	$ I_{OUT}  < 1\ \mu\text{A}$ $V_{IN} = V_{SS}, V_{DD}$	5	4.95	—	4.95	5.00	—	4.95	—	V	
			10	9.95	—	9.95	10.00	—	9.95	—		
			15	14.95	—	14.95	15.00	—	14.95	—		
Low-level output voltage	$V_{OL}$	$ I_{OUT}  < 1\ \mu\text{A}$ $V_{IN} = V_{SS}, V_{DD}$	5	—	0.05	—	0.00	0.05	—	0.05	V	
			10	—	0.05	—	0.00	0.05	—	0.05		
			15	—	0.05	—	0.00	0.05	—	0.05		
Output high current	$I_{OH}$	$V_{OH} = 4.6\text{ V}$ $V_{OH} = 2.5\text{ V}$ $V_{OH} = 9.5\text{ V}$ $V_{OH} = 13.5\text{ V}$ $V_{IN} = V_{SS}, V_{DD}$	5	-0.61	—	-0.51	-1.0	—	-0.42	—	mA	
			5	-2.50	—	-2.10	-4.0	—	-1.70	—		
			10	-1.50	—	-1.30	-2.2	—	-1.10	—		
			15	-4.00	—	-3.40	-9.0	—	-2.80	—		
Output low current	$I_{OL}$	$V_{OL} = 0.4\text{ V}$ $V_{OL} = 0.5\text{ V}$ $V_{OL} = 1.5\text{ V}$ $V_{IN} = V_{SS}, V_{DD}$	5	0.61	—	0.51	1.2	—	0.42	—	mA	
			10	1.50	—	1.30	3.2	—	1.10	—		
			15	4.00	—	3.40	12.0	—	2.80	—		
Input high voltage	$V_{IH}$	$V_{OUT} = 0.5\text{ V}, 4.5\text{ V}$ $V_{OUT} = 1.0\text{ V}, 9.0\text{ V}$ $V_{OUT} = 1.5\text{ V}, 13.5\text{ V}$ $ I_{OUT}  < 1\ \mu\text{A}$	5	3.5	—	3.5	2.75	—	3.5	—	V	
			10	7.0	—	7.0	5.50	—	7.0	—		
			15	11.0	—	11.0	8.25	—	11.0	—		
Input low voltage	$V_{IL}$	$V_{OUT} = 0.5\text{ V}, 4.5\text{ V}$ $V_{OUT} = 1.0\text{ V}, 9.0\text{ V}$ $V_{OUT} = 1.5\text{ V}, 13.5\text{ V}$ $ I_{OUT}  < 1\ \mu\text{A}$	5	—	1.5	—	2.25	1.5	—	1.5	V	
			10	—	3.0	—	4.50	3.0	—	3.0		
			15	—	4.0	—	6.75	4.0	—	4.0		
Input current	"H" level	$I_{IH}$	$V_{IH} = 18\text{ V}$	18	—	0.1	—	$10^{-5}$	0.1	—	1.0	$\mu\text{A}$
	"L" level	$I_{IL}$	$V_{IL} = 0\text{ V}$	18	—	-0.1	—	$-10^{-5}$	-0.1	—	-1.0	
Quiescent supply current	$I_{DD}$	$V_{IN} = V_{SS}, V_{DD}$ (Note)	5	—	1	—	0.002	1	—	30	$\mu\text{A}$	
			10	—	2	—	0.004	2	—	60		
			15	—	4	—	0.008	4	—	120		

Note: All valid input combinations.

**Dynamic Electrical Characteristics (Ta = 25°C, Vss = 0 V, CL = 50 pF)**

Characteristics	Symbol	Test Condition	VDD (V)	Min	Typ.	Max	Unit
Output transition time (low to high)	t <sub>TLH</sub>	—	5	—	70	200	ns
			10	—	35	100	
			15	—	30	80	
Output transition time (high to low)	t <sub>THL</sub>	—	5	—	70	200	ns
			10	—	35	100	
			15	—	30	80	
Propagation delay time (CLOCK-Q, $\bar{Q}$ )	t <sub>pLH</sub> t <sub>pHL</sub>	—	5	—	150	300	ns
			10	—	75	130	
			15	—	60	90	
Propagation delay time (SET, RESET-Q, $\bar{Q}$ )	t <sub>pLH</sub> t <sub>pHL</sub>	—	5	—	120	300	ns
			10	—	60	130	
			15	—	45	90	
Max clock frequency	f <sub>CL</sub>	—	5	3.5	8	—	MHz
			10	8.0	16	—	
			15	12.0	20	—	
Max clock input rise time Max clock input fall time	t <sub>rCL</sub> t <sub>fCL</sub>	—	5	No limit			μs
			10				
			15				
Min pulse width (SET, RESET)	t <sub>w</sub>	—	5	—	60	180	ns
			10	—	35	80	
			15	—	25	50	
Min clock pulse width	t <sub>w</sub>	—	5	—	60	140	ns
			10	—	35	60	
			15	—	25	40	
Min set-up time (J, K-CLOCK)	t <sub>SU</sub>	—	5	—	30	140	ns
			10	—	10	50	
			15	—	5	35	
Min hold time (J, K-CLOCK)	t <sub>H</sub>	—	5	—	—	140	ns
			10	—	—	50	
			15	—	—	35	
Min removal time (SET, RESET-CLOCK)	t <sub>rem</sub>	—	5	—	—	40	ns
			10	—	—	20	
			15	—	—	15	
Input capacitance	C <sub>IN</sub>	—	—	5	7.5	pF	

**Waveforms for Measurement of Dynamic Characteristics**

**Waveform 1**

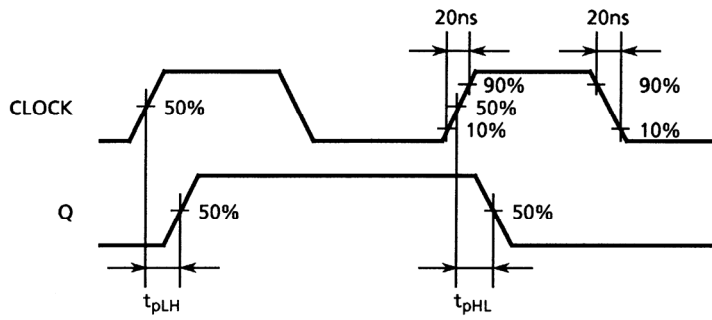

**Waveform 2**

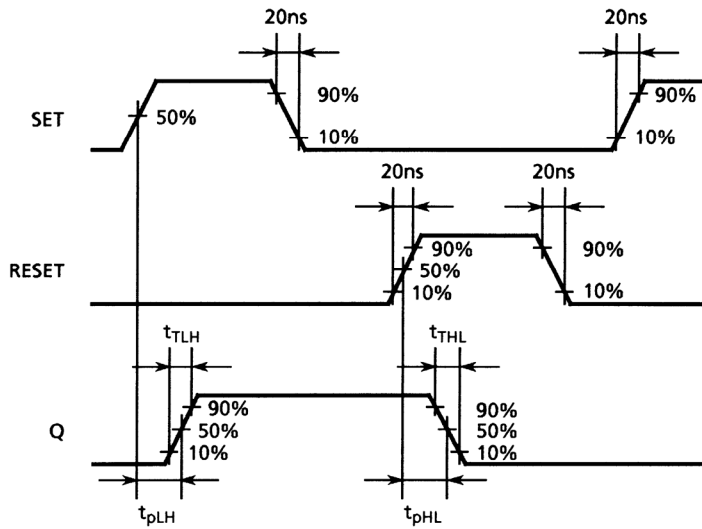

**Waveform 3**

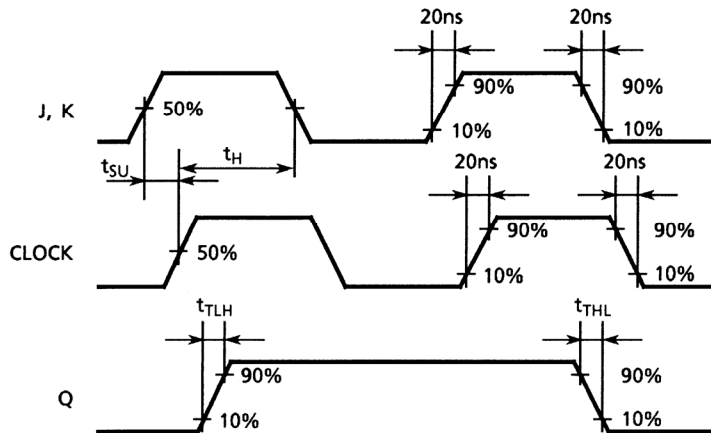

## Package Dimensions

DIP16-P-300-2.54A

Unit : mm

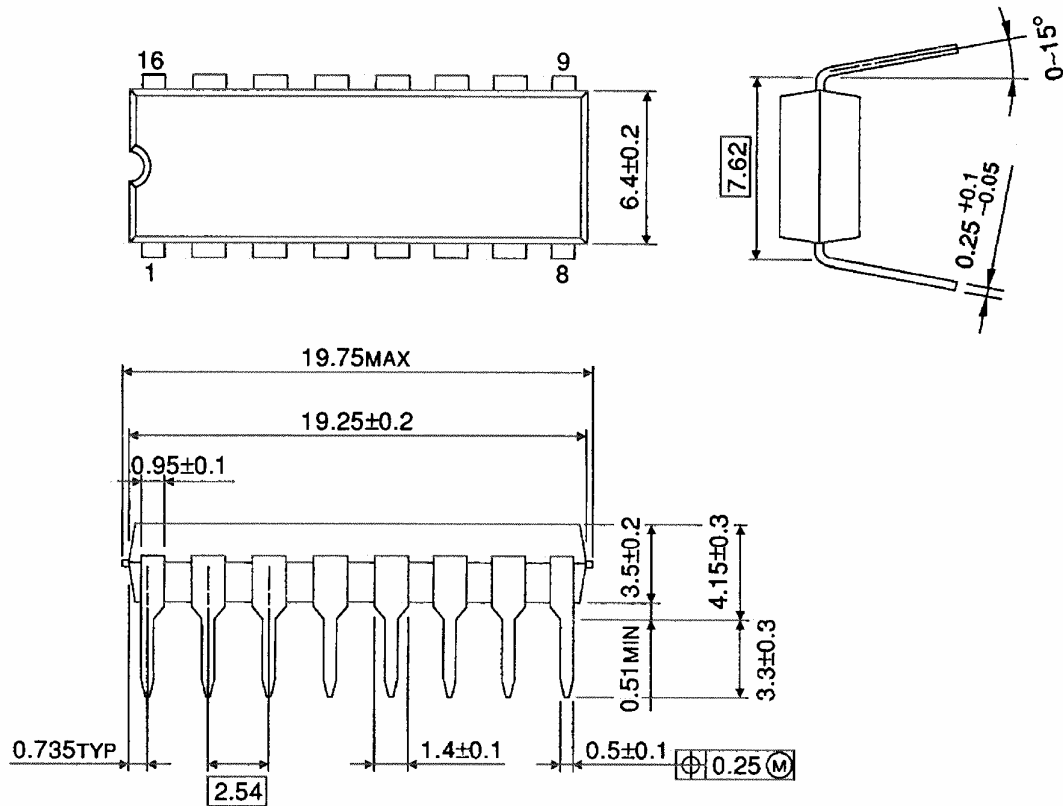

Weight: 1.00 g (typ.)

## Package Dimensions

SOP16-P-300-1.27A

Unit: mm

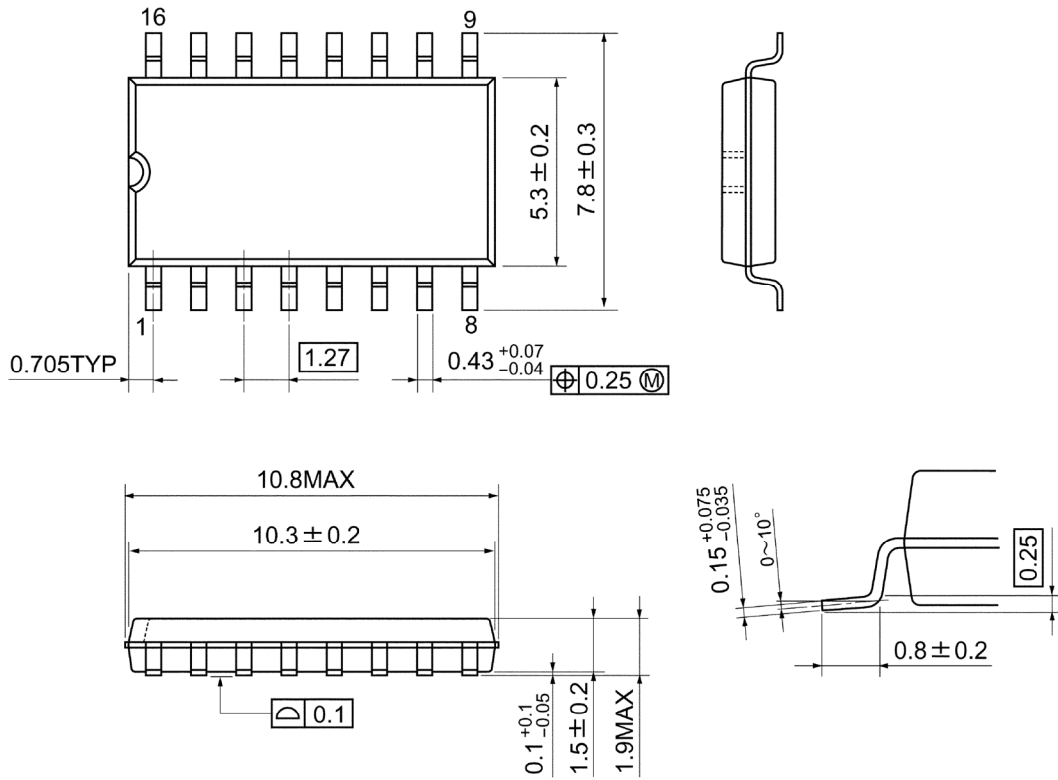

Weight: 0.18 g (typ.)

## Package Dimensions

SOP16-P-300-1.27

Unit : mm

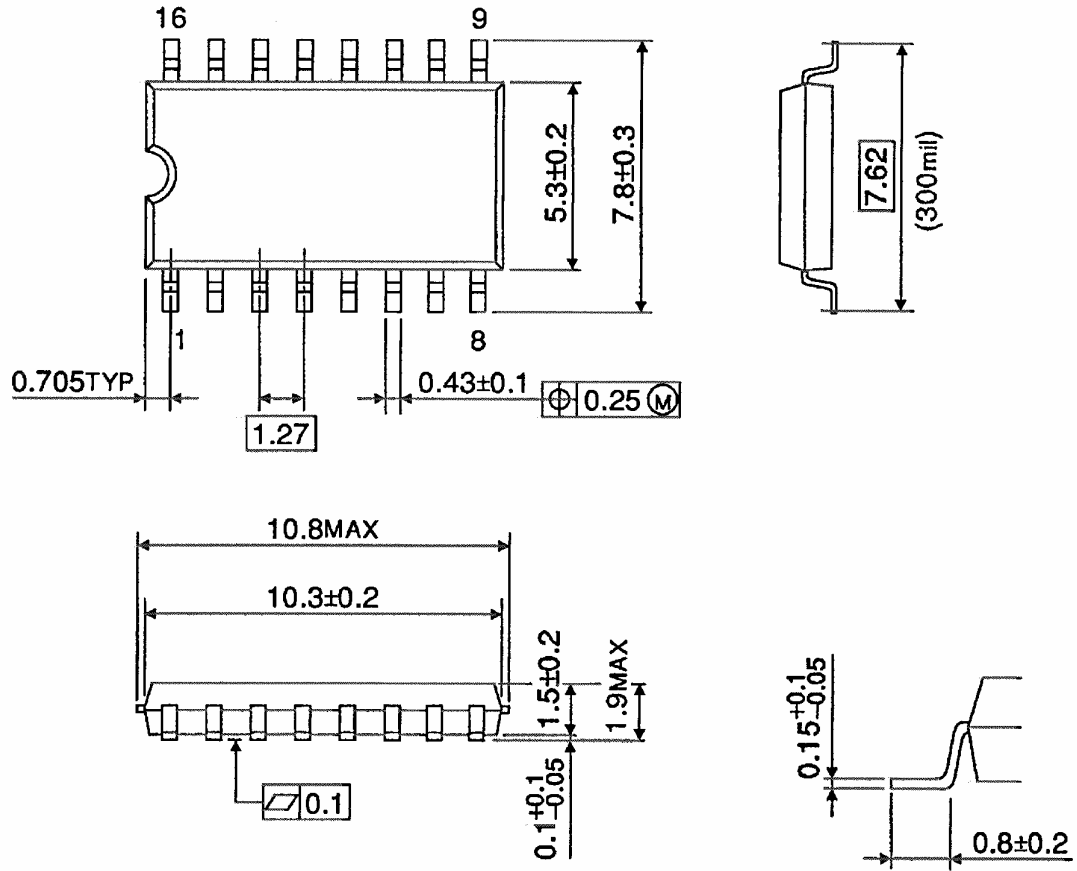

Weight: 0.18 g (typ.)



## Package Dimensions (Note)

SOL16-P-150-1.27

Unit : mm

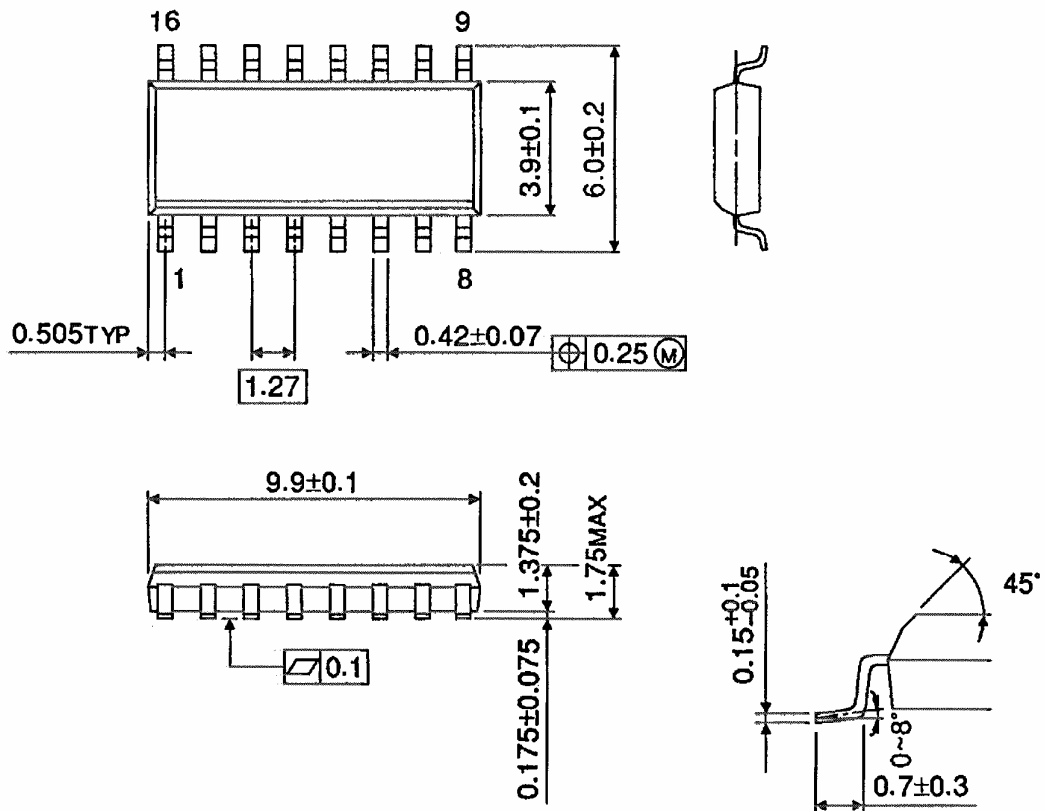

Note: This package is not available in Japan.

Weight: 0.13 g (typ.)

**Note: Lead (Pb)-Free Packages****DIP16-P-300-2.54A SOP16-P-300-1.27A SOL16-P-150-1.27****RESTRICTIONS ON PRODUCT USE**

060116EBA

- The information contained herein is subject to change without notice. 021023\_D
- TOSHIBA is continually working to improve the quality and reliability of its products. Nevertheless, semiconductor devices in general can malfunction or fail due to their inherent electrical sensitivity and vulnerability to physical stress. It is the responsibility of the buyer, when utilizing TOSHIBA products, to comply with the standards of safety in making a safe design for the entire system, and to avoid situations in which a malfunction or failure of such TOSHIBA products could cause loss of human life, bodily injury or damage to property.  
In developing your designs, please ensure that TOSHIBA products are used within specified operating ranges as set forth in the most recent TOSHIBA products specifications. Also, please keep in mind the precautions and conditions set forth in the "Handling Guide for Semiconductor Devices," or "TOSHIBA Semiconductor Reliability Handbook" etc. 021023\_A
- The TOSHIBA products listed in this document are intended for usage in general electronics applications (computer, personal equipment, office equipment, measuring equipment, industrial robotics, domestic appliances, etc.). These TOSHIBA products are neither intended nor warranted for usage in equipment that requires extraordinarily high quality and/or reliability or a malfunction or failure of which may cause loss of human life or bodily injury ("Unintended Usage"). Unintended Usage include atomic energy control instruments, airplane or spaceship instruments, transportation instruments, traffic signal instruments, combustion control instruments, medical instruments, all types of safety devices, etc. Unintended Usage of TOSHIBA products listed in this document shall be made at the customer's own risk. 021023\_B
- The products described in this document shall not be used or embedded to any downstream products of which manufacture, use and/or sale are prohibited under any applicable laws and regulations. 060106\_Q
- The information contained herein is presented only as a guide for the applications of our products. No responsibility is assumed by TOSHIBA for any infringements of patents or other rights of the third parties which may result from its use. No license is granted by implication or otherwise under any patent or patent rights of TOSHIBA or others. 021023\_C
- The products described in this document are subject to the foreign exchange and foreign trade laws. 021023\_E