

IRK. SERIES

THYRISTOR/ DIODE and THYRISTOR/ THYRISTOR

INT-A-pak™ Power Modules

Features

- High voltage
- Electrically isolated base plate
- 3000 V_{RMS} isolating voltage
- Industrial standard package
- Simplified mechanical designs, rapid assembly
- High surge capability
- Large creepage distances
- UL E78996 approved 

135 A
140 A
160 A

Description

These series of INT-A-paks modules uses high voltage power thyristors/ diodes in seven basic configurations. The semiconductors are electrically isolated from the metal base, allowing common heatsinks and compact assemblies to be built. They can be interconnected to form single phase or three phase bridges or as AC-switches when modules are connected in anti-parallel. These modules are intended for general purpose applications such as battery chargers, welders and plating equipment and where high voltage and high current are required (motor drives, U.P.S., etc.).

Major Ratings and Characteristics

Parameters	IRK.135.. IRK.136..	IRK.141.. IRK.142..	IRK.161.. IRK.162..	Units
$I_{T(AV)}$	135	140	160	A
@ T_C	85	85	85	°C
$I_{T(RMS)}$	300	310	355	A
I_{TSM} @ 50Hz	3200	4750	5100	A
@ 60Hz	3360	5000	5350	A
I^2t @ 50Hz	51.5	113	131	KA ² s
@ 60Hz	47	103	119	KA ² s
$I^2\sqrt{t}$	515	1130	1310	KA ² √s
V_{DRM} / V_{RRM}	upto1600	upto2000	upto1600	V
T_J range	-40 to 130	-40 to 125		°C

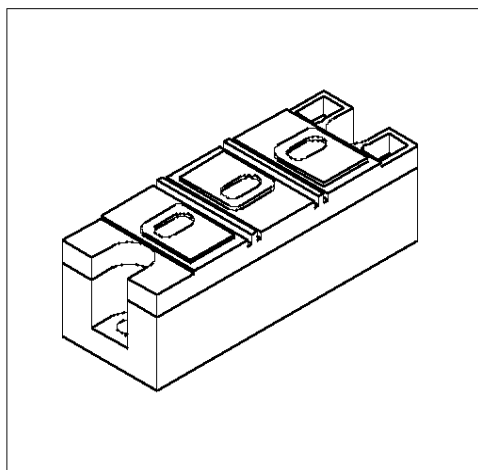

IRK.135, .136, .141, .142, .161, .162 Series

Bulletin I27101 rev. A 09/97

International
IR Rectifier

ELECTRICAL SPECIFICATIONS

Voltage Ratings

Type number	Voltage Code	V _{RRM} , maximum repetitive peak reverse voltage V	V _{RSM} , maximum non-repetitive peak reverse voltage V	I _{RRM} max. @ 150°C mA
IRK.135, IRK.136 IRK.161, IRK.162	04	400	500	50
	08	800	900	
	12	1200	1300	
	14	1400	1500	
	16	1600	1700	
IRK.141, IRK.142	08	800	900	50
	12	1200	1300	
	16	1600	1700	
	18	1800	1900	
	20	2000	2100	

Forward Conduction

Parameter	IRK.135. IRK.136.	IRK.141. IRK.142.	IRK.161. IRK.162.	Units	Conditions
I _{T(AV)} Max. average on-state current @ Case temperature	135 85	140 85	160 85	A °C	180° conduction, half sine wave
I _{T(RMS)} Max. RMS on-state current	300	310	355	A	as AC switch
I _{TSM} Maximum peak, one-cycle on-state, non-repetitive surge current	3200	4750	5100	A	t = 10ms No voltage
	3360	5000	5350		t = 8.3ms reapplied
	2700	4000	4300		t = 10ms 100% V _{RRM}
	2800	4200	4500		t = 8.3ms reapplied
I ² t Maximum I ² t for fusing	51.5	113	131	KA ² s	t = 10ms No voltage
	47	103	119		t = 8.3ms reapplied
	36	80	92		t = 10ms 100% V _{RRM}
	33	73	84		t = 8.3ms reapplied
I ² √t Maximum I ² √t for fusing	515	1130	1310	KA ² √s	t = 0.1 to 10ms, no voltage reapplied
					(16.7% × π × I _{T(AV)} < I < π × I _{T(AV)}), @ T _J max.
V _{T(TO)1} Low level value of threshold voltage	0.98	0.75	0.79	V	(I > π × I _{T(AV)}), @ T _J max.
V _{T(TO)2} High level value of threshold voltage	101	0.86	0.92		
r _{θ1} Low level value on-state slope resistance	1.62	0.92	0.64	mΩ	(16.7% × π × I _{T(AV)} < I < π × I _{T(AV)}), @ T _J max.
r _{θ2} High level value on-state slope resistance	1.56	0.77	0.49		(I > π × I _{T(AV)}), @ T _J max.
V _{FM} Maximum forward voltage drop	1.66	1.32	1.26	V	I _{FM} = π × I _{F(AV)} , T _J = max., 180° conduction Av. power = V _{F(TO)} × I _{F(AV)} + r _f × (I _{F(RMS)}) ²
I _H Maximum holding current	500			mA	Anode supply = 12V initial I _T = 30A, T _J = 25°C
I _L Maximum latching current	300			mA	Anode supply = 12V resistive load = 1Ω gate pulse: 10V, 100μs, T _J = 25°C

Switching

Parameter	IRK.135. IRK.136.	IRK.141. IRK.142.	IRK.161. IRK.162.	Units	Conditions
t_d Typical delay time	2.0	1.0	1.0	μs	$T_J = 25^\circ\text{C}$ Gate Current = 1 A $di/dt = 1\text{A}/\mu\text{s}$
t_r Typical rise time	3.0	2.0	2.0	μs	$T_J = 25^\circ\text{C}$ $V_d = 0.67\% V_{\text{DRM}}$
t_q Typical turn-off time	50 - 150			μs	$I_{\text{TM}} = 300\text{ A}$; $-di/dt = 15\text{ A}/\mu\text{s}$; $T_J = T_J \text{ max}$ $V_r = 50\text{ V}$; $dV/dt = 20\text{ V}/\mu\text{s}$; Gate 0 V, 100 Ω

Blocking

Parameter	IRK.135. IRK.136.	IRK.141. IRK.142.	IRK.161. IRK.162.	Units	Conditions
I_{RRM} Maximum peak reverse and I_{DRM} off-state leakage current	50			mA	$T_J = 150^\circ\text{C}$
V_{INS} RMS isolation voltage	3000			V	50Hz, circuit to base, all terminals shorted, $t = 1\text{ s}$
dv/dt critical rate of rise of off-state voltage	1000			V/ μs	$T_J = T_J \text{ max.}$, exponential to 67% rated V_{DRM}

Triggering

Parameter	IRK.135. IRK.136.	IRK.141. IRK.142.	IRK.161. IRK.162.	Units	Conditions
P_{GM} Max. peak gate power	5	10	10	W	$t_p \leq 5\text{ms}$, $T_J = T_J \text{ max.}$
$P_{\text{G(AV)}}$ Max. average gate power	1	2	2	W	$f = 50\text{Hz}$, $T_J = T_J \text{ max.}$
I_{GM} Max. peak gate current	2	3	3	A	$t_p \leq 5\text{ms}$, $T_J = T_J \text{ max.}$
$-V_{\text{GT}}$ Max. peak negative gate voltage	5	5	5	V	
V_{GT} Max. required DC gate voltage to trigger	4.0	4.0	4.0	V	$T_J = -40^\circ\text{C}$ Anode supply = 12V, resistive $T_J = 25^\circ\text{C}$ load; $R_a = 1\Omega$ $T_J = T_J \text{ max.}$
	3.0	3.0	3.0		
	2.0	2.0	2.0		
I_{GT} Max. required DC gate current to trigger	350	350	350	mA	$T_J = -40^\circ\text{C}$ Anode supply = 12V, resistive $T_J = 25^\circ\text{C}$ load; $R_a = 1\Omega$ $T_J = T_J \text{ max.}$
	200	200	200		
	100	100	100		
V_{GD} Max. gate voltage that will not trigger	0.25	0.30	0.30	V	@ $T_J = T_J \text{ max.}$, rated V_{DRM} applied
I_{GD} Max. gate current that will not trigger	10	10	10	mA	
di/dt Max. rate of rise of turned-on current	300	500	500	A/ μs	@ $T_J = T_J \text{ max.}$, $I_{\text{TM}} = 400\text{A}$ rated V_{DRM} applied

Thermal and Mechanical Specifications

Parameter	IRK.135. IRK.136.	IRK.141. IRK.142.	IRK.161. IRK.162.	Units	Conditions
T_J Max. junction operating temperature range	-40 to 130	-40 to 150		$^\circ\text{C}$	
T_{stg} Max. storage temperature range	-40 to 150			$^\circ\text{C}$	
R_{thJC} Max. thermal resistance, junction to case	0.20	0.17	0.17	K/W	DC operation, per junction
R_{thCS} Max. thermal resistance, case to heatsink	0.05			K/W	Mounting surface smooth, flat and greased Per module
T Mounting IAP to heatsink torque $\pm 10\%$ busbar to IAP	4 to 6			Nm	A mounting compound is recommended and the torque should be rechecked after a period of 3 hours to allow for the spread of the compound. Lubricated threads.
	4 to 6				
wt Approximate weight	500 (17.8)			g (oz)	

IRK.135, .136, .141, .142, .161, .162 Series

Bulletin I27101 rev. A 09/97

International
IR Rectifier

ΔR Conduction (per Junction)

(The following table shows the increment of thermal resistance R_{thJC} when devices operate at different conduction angles than DC)

Devices	Sinusoidal conduction @ T_J max.					Rectangular conduction @ T_J max.					Units
	180°	120°	90°	60°	30°	180°	120°	90°	60°	30°	
IRK.135, IRK.136	0.016	0.019	0.024	0.035	0.060	0.011	0.019	0.026	0.037	0.060	K/W
IRK.141, IRK.142	0.016	0.019	0.025	0.036	0.060	0.012	0.020	0.027	0.037	0.060	
IRK.161, IRK.162	0.015	0.019	0.024	0.036	0.060	0.012	0.020	0.027	0.037	0.060	

INT-A-paks Suitable for Current Source Inverters

Thyristor		Diode	$I_{T(AV)} / I_{F(AV)} @ T_C$		
V_{DRM}	V_{RSM}	V_{RRM}	135A	140A	160A
V_{RRM}		V_{RSM}	@ 85°C	@ 85°C	@ 85°C
1400	1500	2000	IRKH135-14D20	IRKH141-14D20	IRKH161-14D20
1400	1500	2000	IRKH136-14D20	IRKH142-14D20	IRKH162-14D20
			IRKL135-14D20	IRKL141-14D20	IRKL161-14D20
			IRKL136-14D20	IRKL142-14D20	IRKL162-14D20
1600	1700	2500	IRKH135-16D25	IRKH141-16D25	IRKH161-16D25
1600	1700	2500	IRKH136-16D25	IRKH142-16D25	IRKH162-16D25
			IRKL136-16D25	IRKL142-16D25	IRKL162-16D25
1800	1900	2800	Not Available	IRKH141-18D28	Not Available
1800	1900	2800	Not Available	IRKL141-18D28	Not Available
			Not Available	IRKL142-18D28	Not Available
			Not Available	IRKL142-18D28	Not Available
2000	2100	3200	Not Available	IRKH141-20D32	Not Available
2000	2100	3200	Not Available	IRKH142-20D32	Not Available
			Not Available	IRKL141-20D32	Not Available
			Not Available	IRKL142-20D32	Not Available

For all other parameters and characteristics refer to standard IRKH... and IRKL... modules.

Application Notes

Current Source Inverter using 9 INT-A-paks

Current Source Inverters

Current-Source Inverters (also known as Sequentially Commutated Inverters) use Phase Control (as opposed to Fast) Thyristors and Diodes.

The advantages of Current Source Inverters lie in their ease control, absence of large commutation inductances and limited fault currents. Their simple construction, illustrated by the circuit on the left, is further enhanced by the use of INT-A-paks which allow the power circuit of an Inverter to be realised with 6 capacitors and 9 INT-A-paks all mounted on just one heatsink.

The optimal design of Current Source Inverters requires the use of Diodes with blocking voltages greater than those of the thyristors. This departure from conventional half-bridge modules is catered for by INT-A-pak range with Thyristors up to 2000V and Diodes up to 3200V.

Ordering Information Table

Device Code

IRK	T	16	2	-	16	D25	N
①	②	③	④		⑤	⑥	⑦

- 1** - Module type
- 2** - Circuit configuration
- 3** - Current rating: $I_{T(AV)} \times 10$ rounded
- 4** - For IRK.13. only:
5 = option with spacers and longer terminal screws
6 = option with standard terminal screws
For IRK.14. and IRK.16. only:
1 = option with spacers and longer terminal screws
2 = option with standard terminal screws
- 5** - Voltage code: Code $\times 100 = V_{RRM}$ (See Voltage Ratings Table)
- 6** - Current Source Inverters types (See Table)
- 7** - None = Standard devices
N = Aluminum nitride substrate

Outline Table

(SEE TABLE)

94(3.70)
80(3.15)
7(0.27)
34(1.34)
5(0.32)
3 Screws M5 x 1
2 HOLES \varnothing 6.5

For all types	A	B	C	D	E
IRK...5 & ...1	25(0.98)	----	----	41(1.61)	47(1.85)
IRK...6 & ...2	23(0.91)	30(1.18)	36(1.42)	----	----

- All dimensions in millimeters (inches)
- Dimensions are nominal
- Full engineering drawings are available on request
- UL identification number for gate and cathode wire: UL 1385
- UL identification number for package: UL 94V0

IRKT...

IRKH...

IRKL...

IRKU...

IRKV...

IRKK...

IRKN...

NOTE: To order the Optional Hardware see Bulletin I27900

IRK.135, .136, .141, .142, .161, .162 Series

Bulletin I27101 rev. A 09/97

International
IRF Rectifier

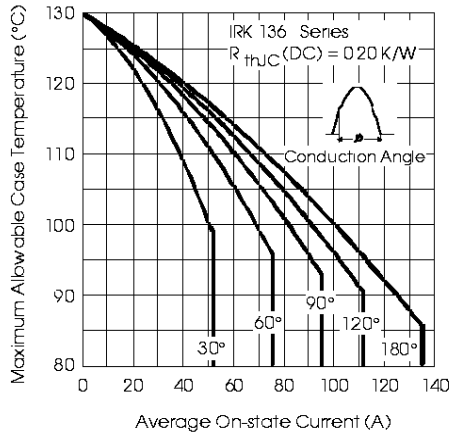

Fig. 1 - Current Ratings Characteristics

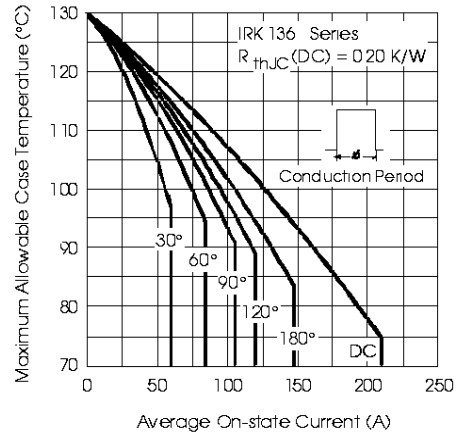

Fig. 2 - Current Ratings Characteristics

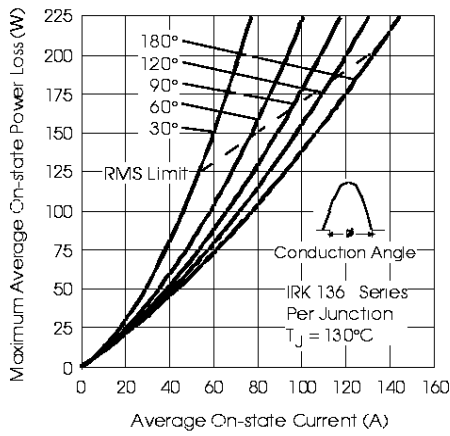

Fig. 3 - On-state Power Loss Characteristics

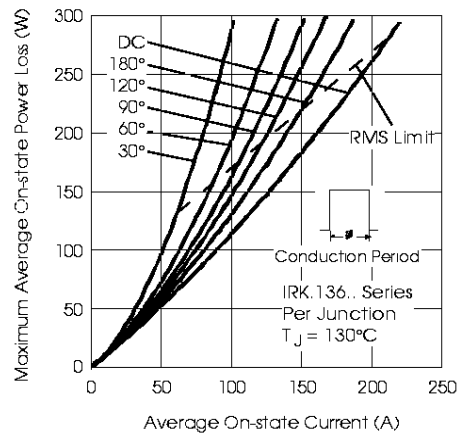

Fig. 4 - On-state Power Loss Characteristics

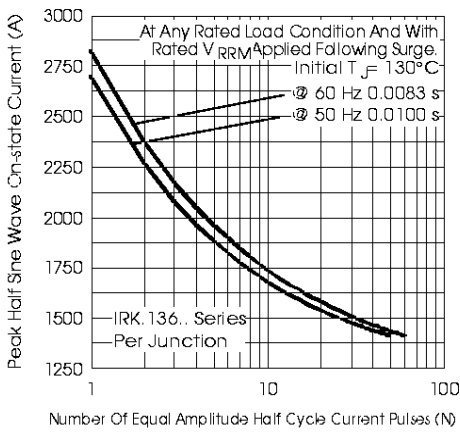

Fig. 5 - Maximum Non-Repetitive Surge Current

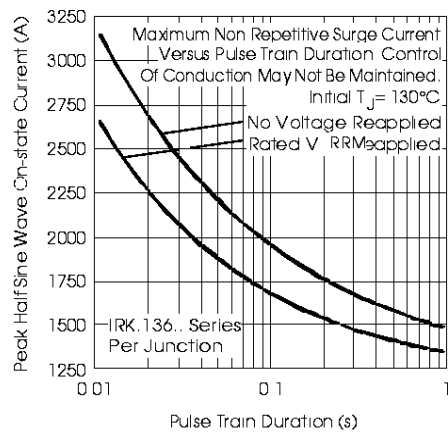

Fig. 6 - Maximum Non-Repetitive Surge Current

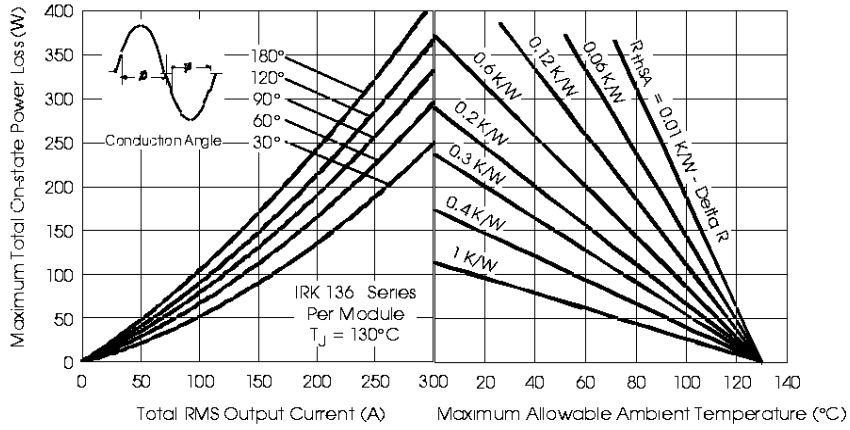

Fig. 7 - On-state Power Loss Characteristics

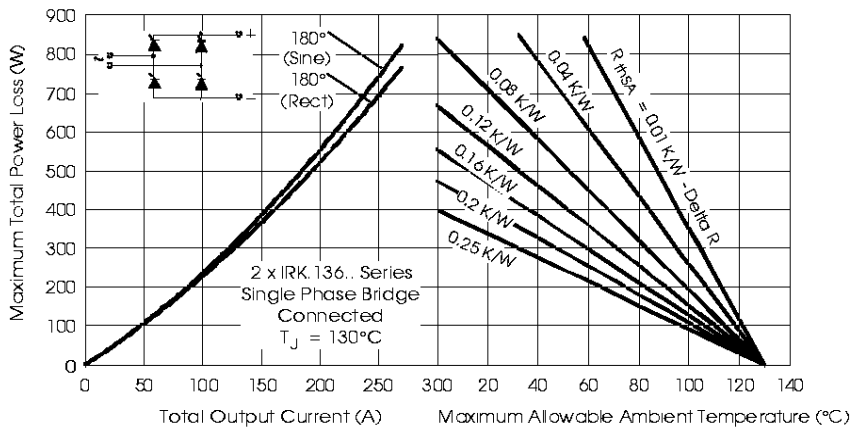

Fig. 8 - On-state Power Loss Characteristics

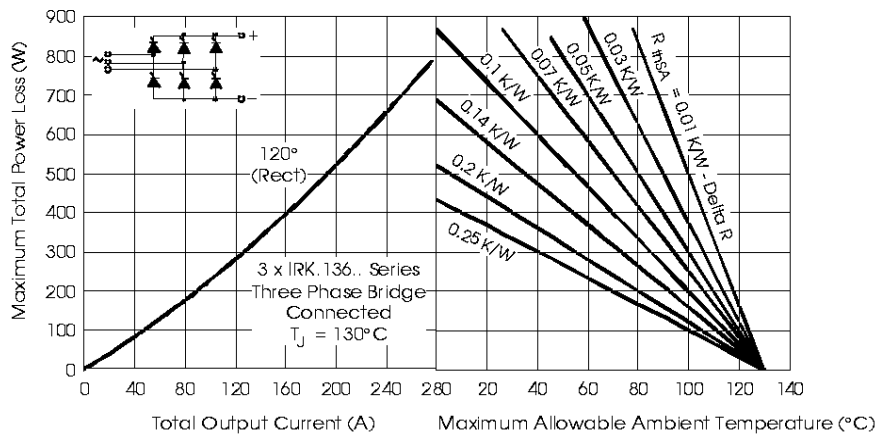

Fig. 9 - On-state Power Loss Characteristics

IRK.135, .136, .141, .142, .161, .162 Series

Bulletin I27101 rev. A 09/97

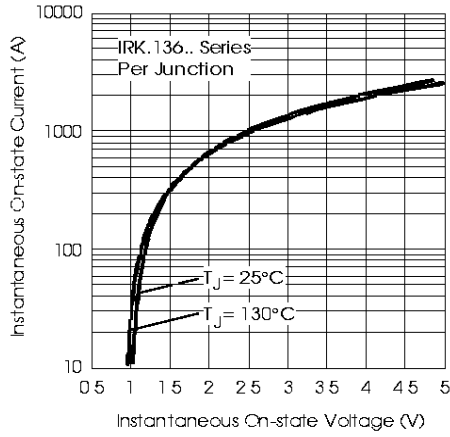

Fig. 10 - On-state Voltage Drop Characteristics

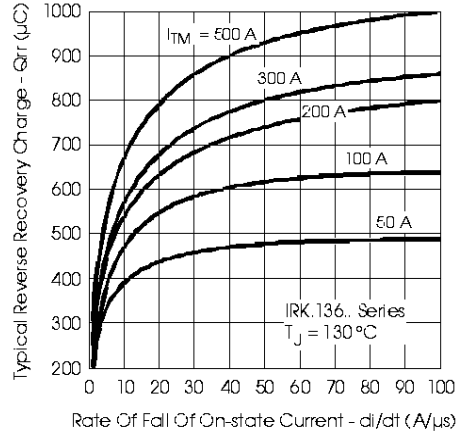

Fig. 11 - Reverse Recovery Charge Characteristics

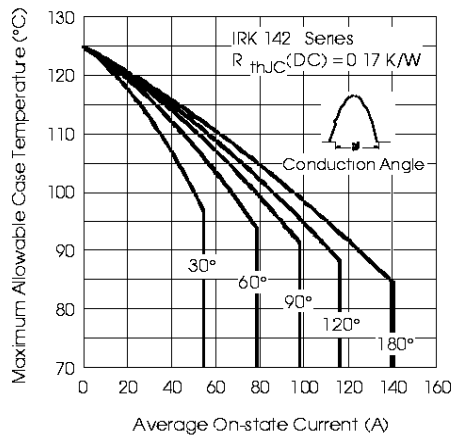

Fig. 12 - Current Ratings Characteristics

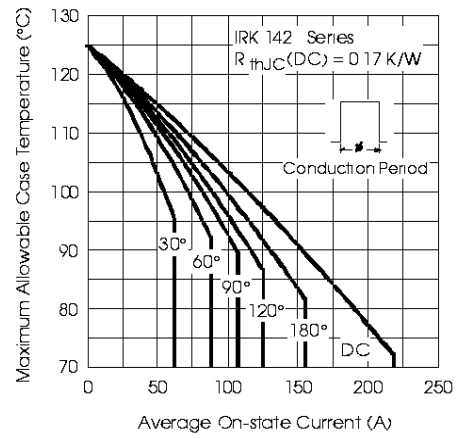

Fig. 13 - Current Ratings Characteristics

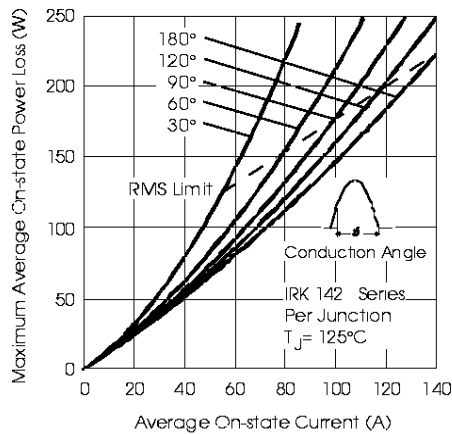

Fig. 14 - On-state Power Loss Characteristics

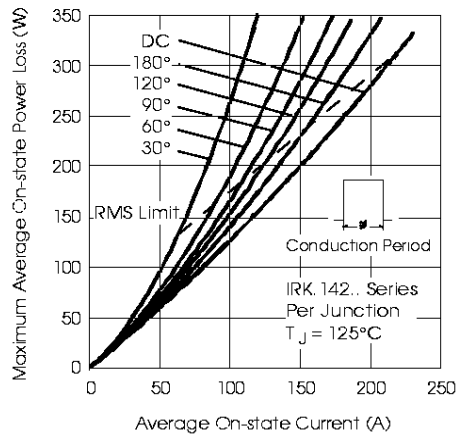

Fig. 15 - On-state Power Loss Characteristics

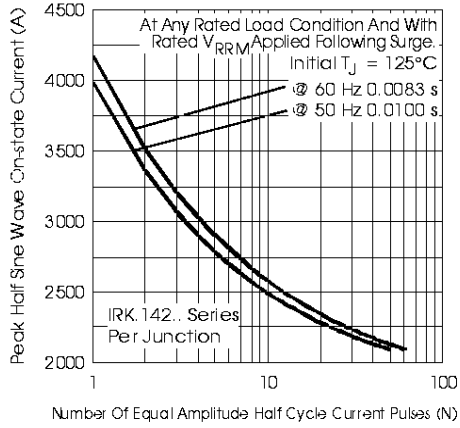

Fig. 16 - Maximum Non-Repetitive Surge Current

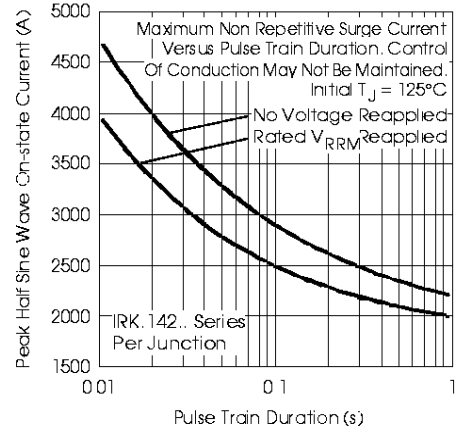

Fig. 17 - Maximum Non-Repetitive Surge Current

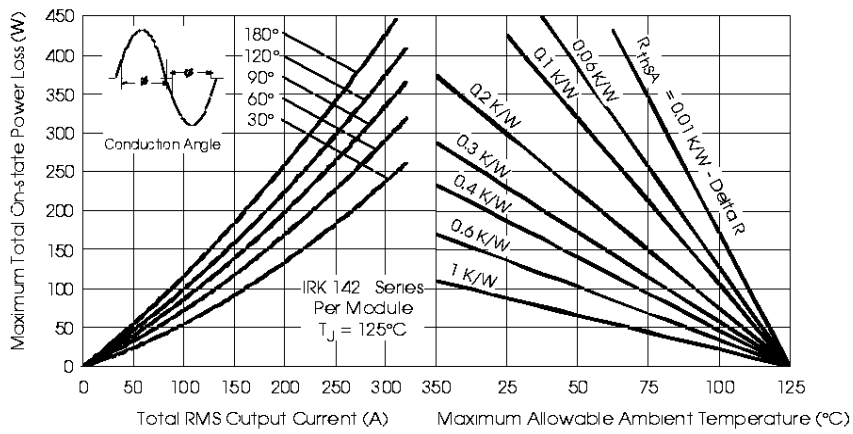

Fig. 18 - On-state Power Loss Characteristics

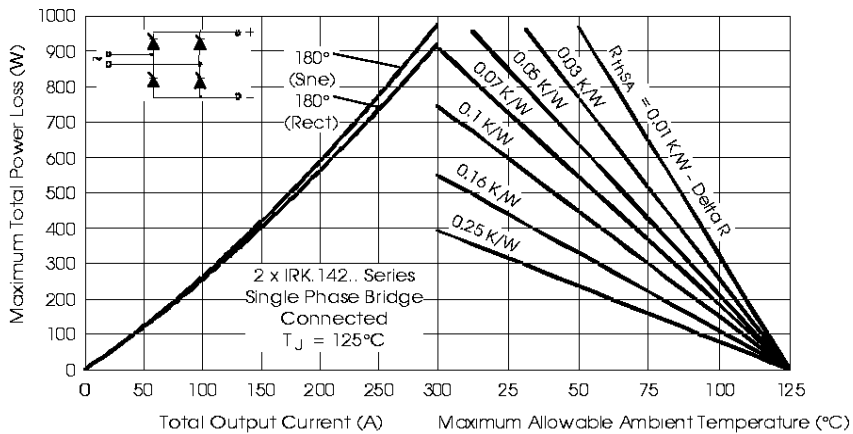

Fig. 19 - On-state Power Loss Characteristics

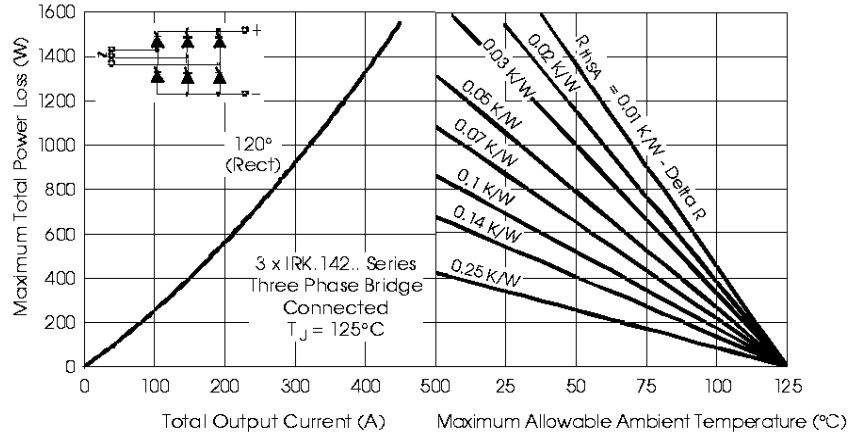

Fig. 20 - On-state Power Loss Characteristics

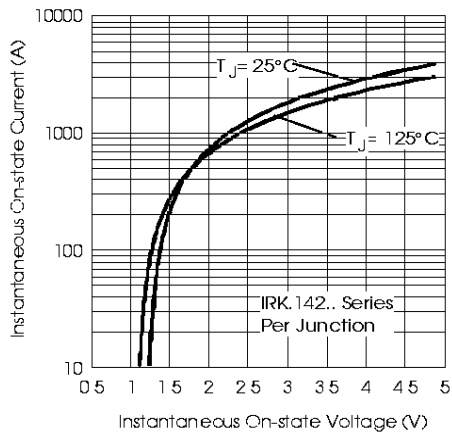

Fig. 21 - On-state Voltage Drop Characteristics

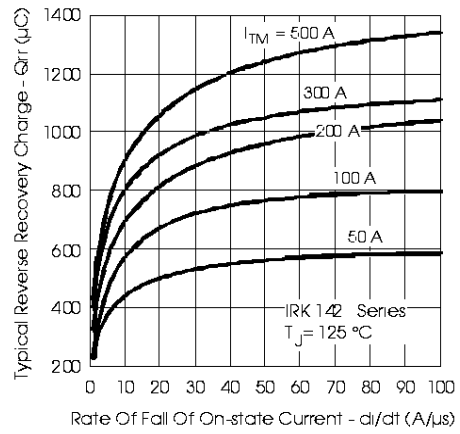

Fig. 22 - Reverse Recovery Charge Characteristics

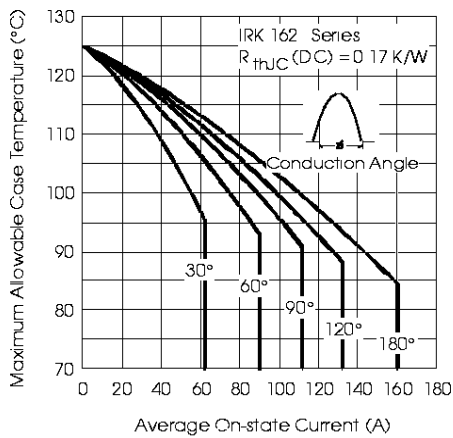

Fig. 23 - Current Ratings Characteristics

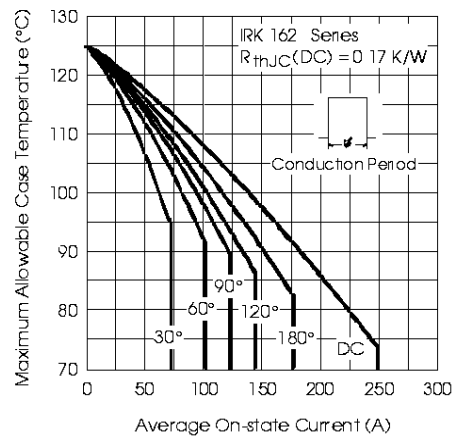

Fig. 24 - Current Ratings Characteristics

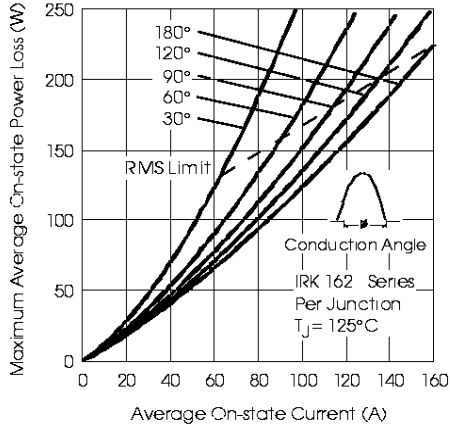

Fig. 25 - On-state Power Loss Characteristics

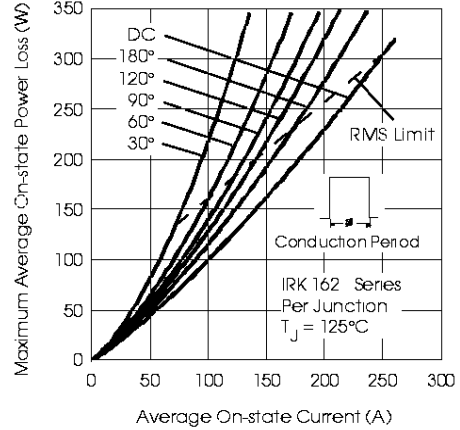

Fig. 26 - On-state Power Loss Characteristics

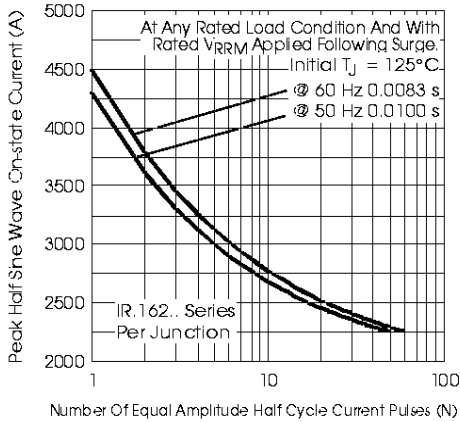

Fig. 27 - Maximum Non-Repetitive Surge Current

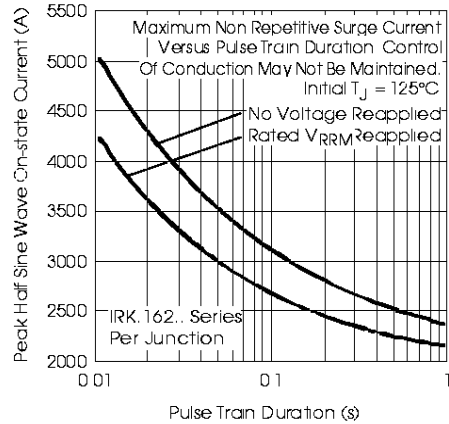

Fig. 28 - Maximum Non-Repetitive Surge Current

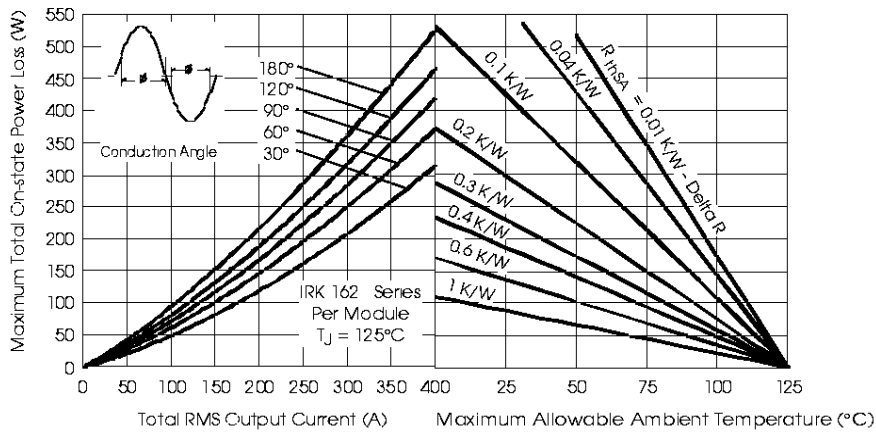

Fig. 29 - On-state Power Loss Characteristics

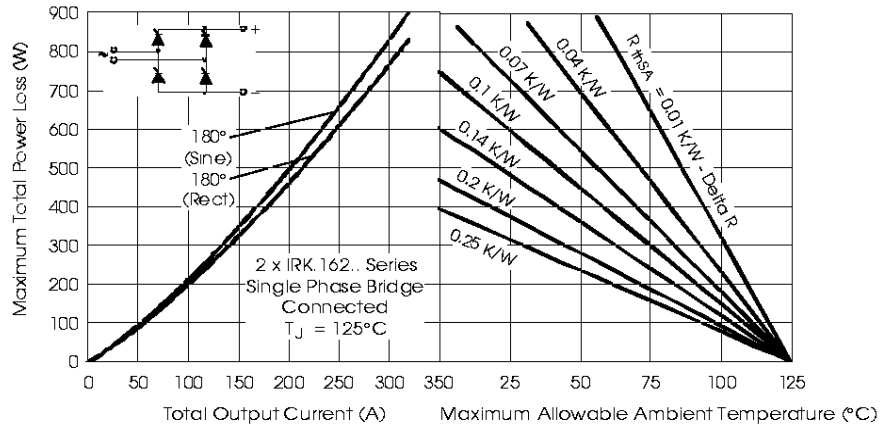

Fig. 30 - On-state Power Loss Characteristics

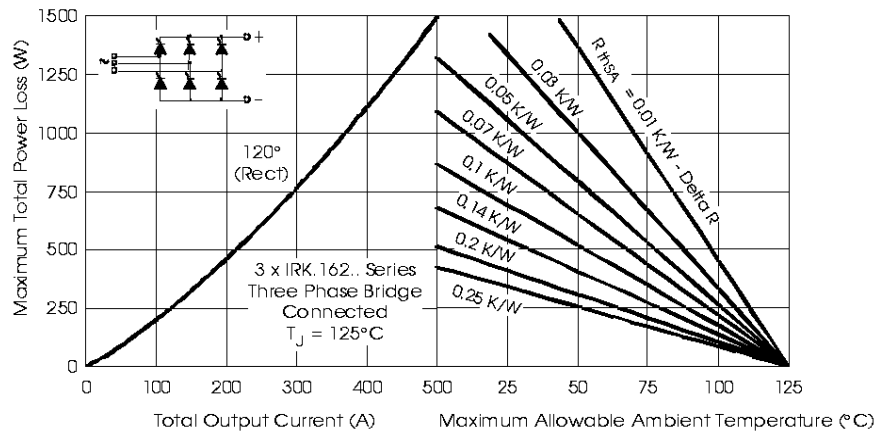

Fig. 31 - On-state Power Loss Characteristics

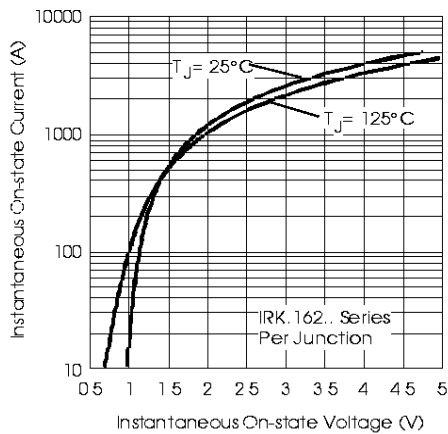

Fig. 32 - On-state Voltage Drop Characteristics

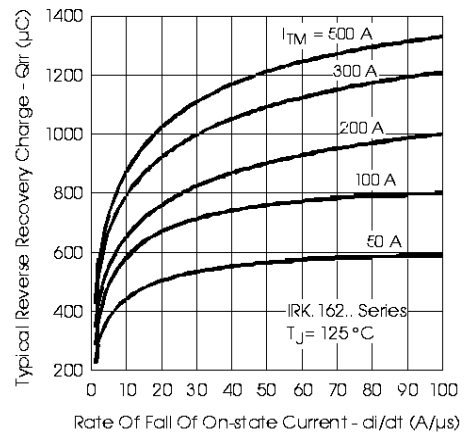

Fig. 33 - Reverse Recovery Charge Characteristics

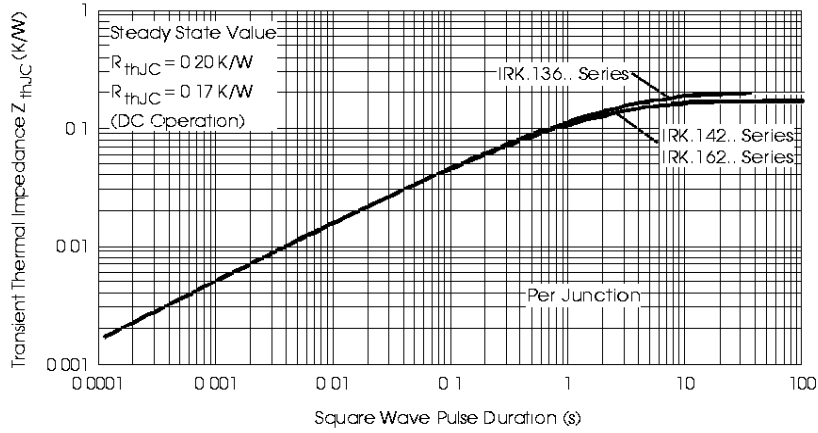

Fig. 34 - Thermal Impedance Z_{thJC} Characteristics

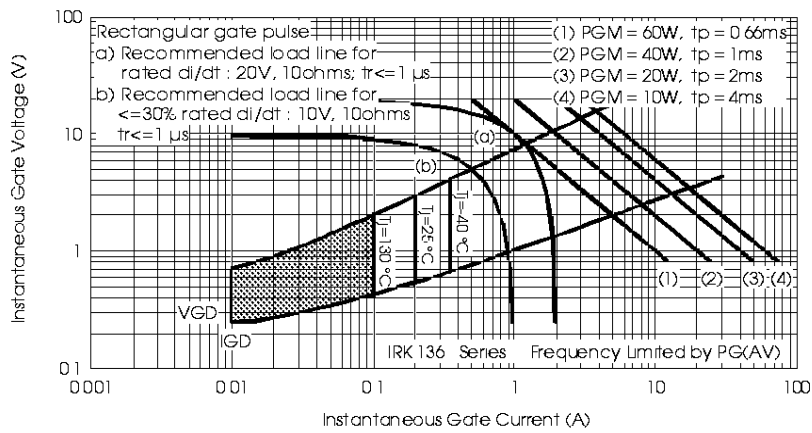

Fig. 35 - Gate Characteristics

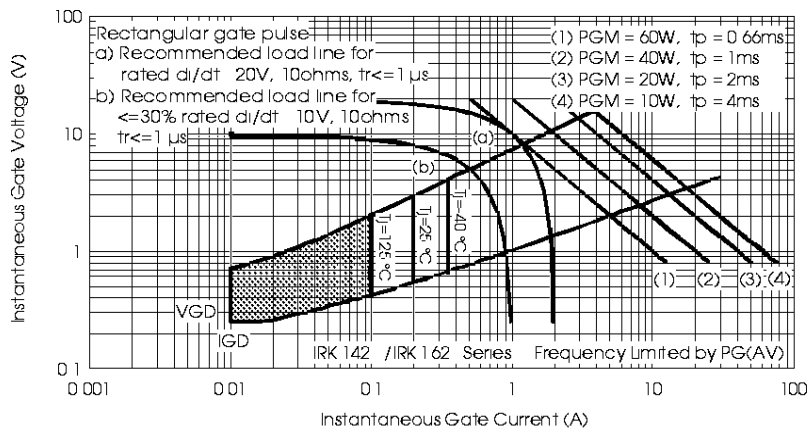

Fig. 36 - Gate Characteristics