

ATS671LSE Specification

Preliminary – Subject to Change

Pin Out Diagram

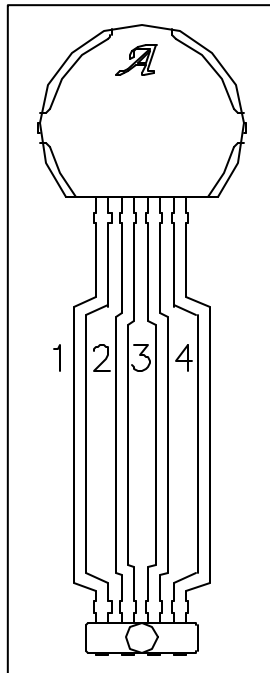

Pin 1: V_{CC}
 Pin 2: V_{OUT}
 Pin 3: Test Pin (Tie to GND)
 Pin 4: Gnd

Self Calibrating TPOS Gear Tooth Sensor with 9Bit Signal Capture

The ATS671LSE true zero speed gear tooth sensors are optimized Hall IC/magnet configurations packaged in a Single In Line Package (SIP) that provides a user-friendly solution for digital gear tooth sensing applications. The SIP module consists of an over-molded package, which holds together a samarium cobalt magnet, a pole piece and a true zero-speed Hall IC that has been optimized to the magnetic circuit. This package can be easily assembled and used in conjunction with gears of various shapes and sizes.

The sensor incorporates a single element Hall IC that switches in response to the magnetic signal created by a ferrous target. The IC contains a sophisticated digital circuit designed to eliminate the detrimental effects of magnet and system offsets. Signal processing is used to provide zero speed performance independent of air gap and also to dynamically adapt device performance to the typical operating conditions found in automotive applications (reduced vibration sensitivity). High-resolution (9-bit) peak detecting DACs are used to set the adaptive switching thresholds of the device. Hysteresis in the thresholds reduces the negative effects of any anomalies in the magnetic signal (such as magnetic overshoot) associated with the targets used in many automotive applications. The ATS671LSE also includes a low bandwidth filter that increases the noise immunity and the signal to noise ratio of the sensor. These features result in potential improvements in both the timing accuracy and the jitter performance of the device.

The ATS671LSE-LT sensor system is optimized for cam applications and is available with or without the TPOS function

ABSOLUTE MAXIMUM RATINGS

Supply Voltage,	
V_{CC}	26.5 V
Reverse Supply Voltage,	
V_R	-18 V
Reverse Output Voltage,	
V_{ORout}	-0.5 V
Continuous Output Current,	
I_{OUT}	20 mA
Storage Temperature,	
T_S	170° C
Package Power Rating,	
$\theta_{JA} \cdot SB$	~150° C/W
Maximum Junction Temperature,	
T_{Jmax}	170° C
Maximum Junction Temperature – 100 Hours,	
T_{Jmax}	180° C

FEATURES

- ♦ Tight timing accuracy over temperature
- ♦ True zero speed operation
- ♦ True power on state
- ♦ Air gap independent switch points
- ♦ High vibration immunity
- ♦ Large operating air gaps
- ♦ Operation down to 3.3V
- ♦ Digital output representing target profile
- ♦ Single chip solution for high reliability
- ♦ Small mechanical size
- ♦ Optimized Hall IC magnetic system
- ♦ AGC and reference adjust circuit
- ♦ Under-voltage lockout

ATS671LSE

SELF CALIBRATING TPOS GEAR TOOTH SENSOR WITH 9BIT SIGNAL CAPTURE

Preliminary – Subject to Change

OPERATING CHARACTERISTICS Valid at $T_a = -40C$ to $150C$ and power supply within specification unless otherwise noted

Characteristics	Symbol	Test Conditions	Limits			
			Min.	Typ.	Max.	Units
ELECTRICAL CHARACTERISTICS						
Supply Voltage	V_{CC}	Operating; $T_j < T_{jmax}$	3.3		26.5	V
Reverse Supply Voltage	V_{RCC}	$I_{RCC} = -5mA$ (max)			-18	V
Supply Zener Clamp Voltage	V_Z		28	33	37	V
Supply Zener Current	I_Z	$T_j < T_{jmax}$; pulsed			100	mA
Supply Current	I_{CC}	Output = OFF	3	6.5	11	mA
		Output = ON	3	6.5	11	mA
POWER-ON STATE CHARACTERISTICS						
Power Up Time	t_{PO}	Gear Speed < 100 RPM; $V_{CC} > 3.3V$	-		500	μS
Under Voltage Lockout	V_{UV}		-		$< V_{CCMin}$	V
OUTPUT STAGE						
Low Output Voltage	V_{LOUT}	$I_{SINK} = 15$ mA, Output = ON	-	0.2	0.45	V
Output Current Limit	I_{lin}	Output = ON, $T_j < T_{jmax}$	25	45	70	mA
Output Leakage Current	I_{OFF}	Output = OFF, $V_{OUT} = V_{CC(Max)}$	-		10	μA
Output Rise Time	t_r	$R_L = 500 \Omega$, $C_L = 10$ pF, $T_a = 25C$	-	0.9	5	μs
Output Fall Time	t_f	$R_L = 500 \Omega$, $C_L = 10$ pF, $T_a = 25C$	-	0.5	5	μs

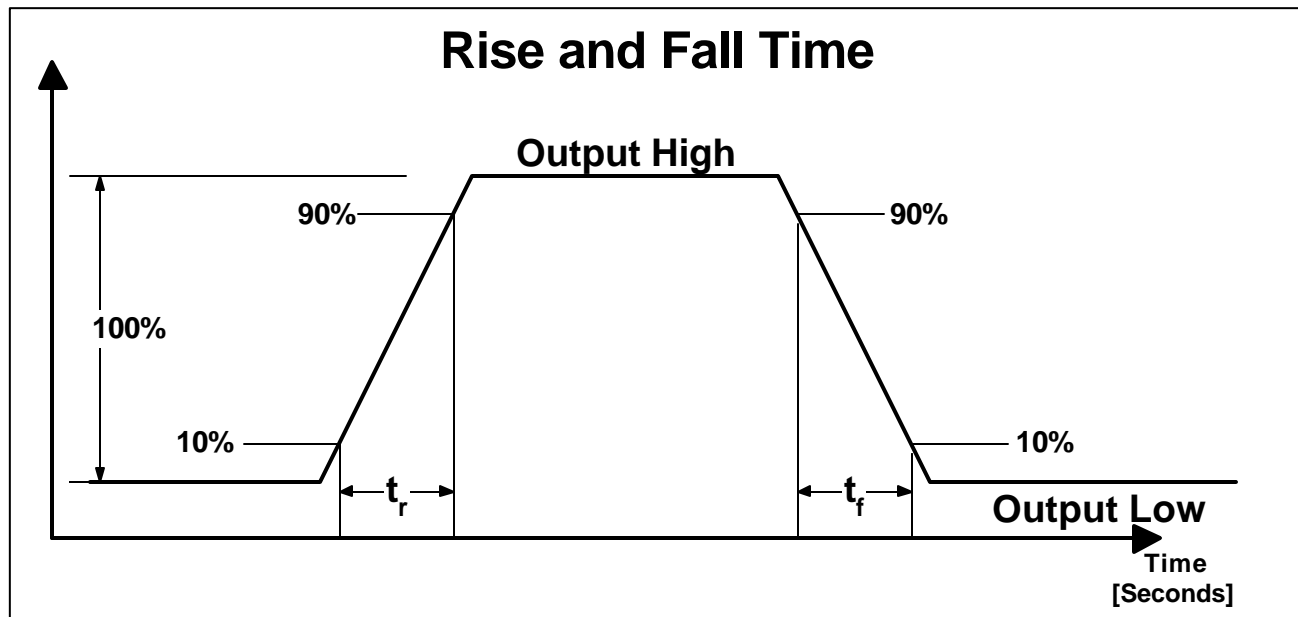

ATS671LSE
SELF CALIBRATING TPOS GEAR TOOTH SENSOR WITH 9BIT SIGNAL CAPTURE
Preliminary – Subject to Change

Characteristics	Symbol	Test Conditions	Limits			Units
			Min.	Typ.	Max.	
SWITCH POINT CHARACTERISTICS						
Tooth Speed	S_{max}		0		8	KHz
Bandwidth	f-3db			40		KHz
Operate Point	Bop%	% of peak to peak referenced to tooth signal, AG < Agmax;		+40		%
Release Point	Brp%	% of peak to peak referenced to tooth signal, AG < Agmax;		+50		%
Output Polarity	Vout	Over Valley		HIGH		
		Over Tooth		LOW		

Calibration					
Initial Calibration	C_i	Number of Rising Mechanical Edges for Accurate Edge Detection		3	Edges
AGC Disable	C_f	Number of Rising Mechanical Edges Required to Complete AGC Calibration		3	Edges

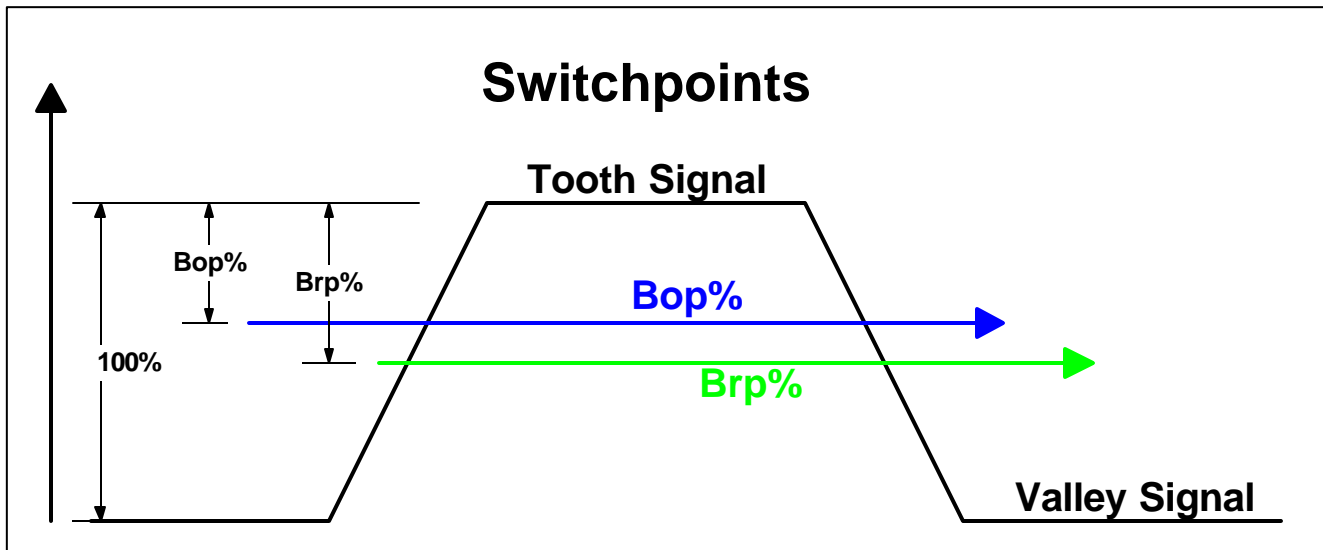

ATS671LSE
SELF CALIBRATING TPOS GEAR TOOTH SENSOR WITH 9BIT SIGNAL CAPTURE
Preliminary – Subject to Change

OPERATION WITH 8X Reference Target over Operational Air Gap and Temperature with Test Circuit #1 Unless Otherwise Stated

Characteristics	Symbol	Test Conditions	Limits			Units
			Min.	Typ.	Max.	
¹ Relative Timing Accuracy	T _{ICRel}	Rising and Falling Edge, RPM = 1000 During Initial Calibration Gear Eccentricity < 0.1mm		3	6	°
	T _{Rel}	Rising Mechanical Edge After Initial Calibration, RPM = 1000 Gear Eccentricity < 0.1mm	-	0.5	0.8	°
	T _{Rel}	Falling Mechanical Edge After Initial Calibration, RPM = 1000 Gear Eccentricity < 0.1mm	-	0.8	1.2	°
² TPOS Air Gap Min	AG _{Min}	Valleys May be Detected as Teeth: Incorrect TPOS	-	-	0.5	mm
³ TPOS Air Gap Range	AG _{TPOS}	Distance for Correct TPOS Functionality	0.5	-	2.5	mm
⁴ TPOS Air Gap Max	AG _{Max}	Teeth May be Detected as a Valley: Incorrect TPOS	2.5	-	5.0	mm
Operational Air Gap Range	AG	Output Switching: Running Mode Only	0.5	-	2.5	mm
Edge Repeatability	t _{θE}	360° Repeatability, 1000 edges		0.04		°

¹ Relative Timing Accuracy Range is the change in edge position over the operational air gap and temperature range.

² The TPOS Air Gap Min is the Installation Air Gap where the device may detect Valleys as Teeth. The True Power On Function is **NOT** guaranteed to operate.

³ The TPOS Air Gap Range is the Installation Air Gap Range where the True Power On Function is guaranteed to operate. Operating is defined as correctly detecting a tooth when powered up over a tooth and correctly detecting a valley when powered up over a valley using the Reference Target. This specification is only valid for targets that meet or exceed the 'Gear Parameters for Correct TPOS Operation' section of this document.

⁴ The TPOS Air Gap Max is the Installation Air Gap where the device may detect a Tooth as a Valley. The True Power On Function is **NOT** guaranteed to operate.

ATS671LSE
SELF CALIBRATING TPOS GEAR TOOTH SENSOR WITH 9BIT SIGNAL CAPTURE
 Preliminary – Subject to Change

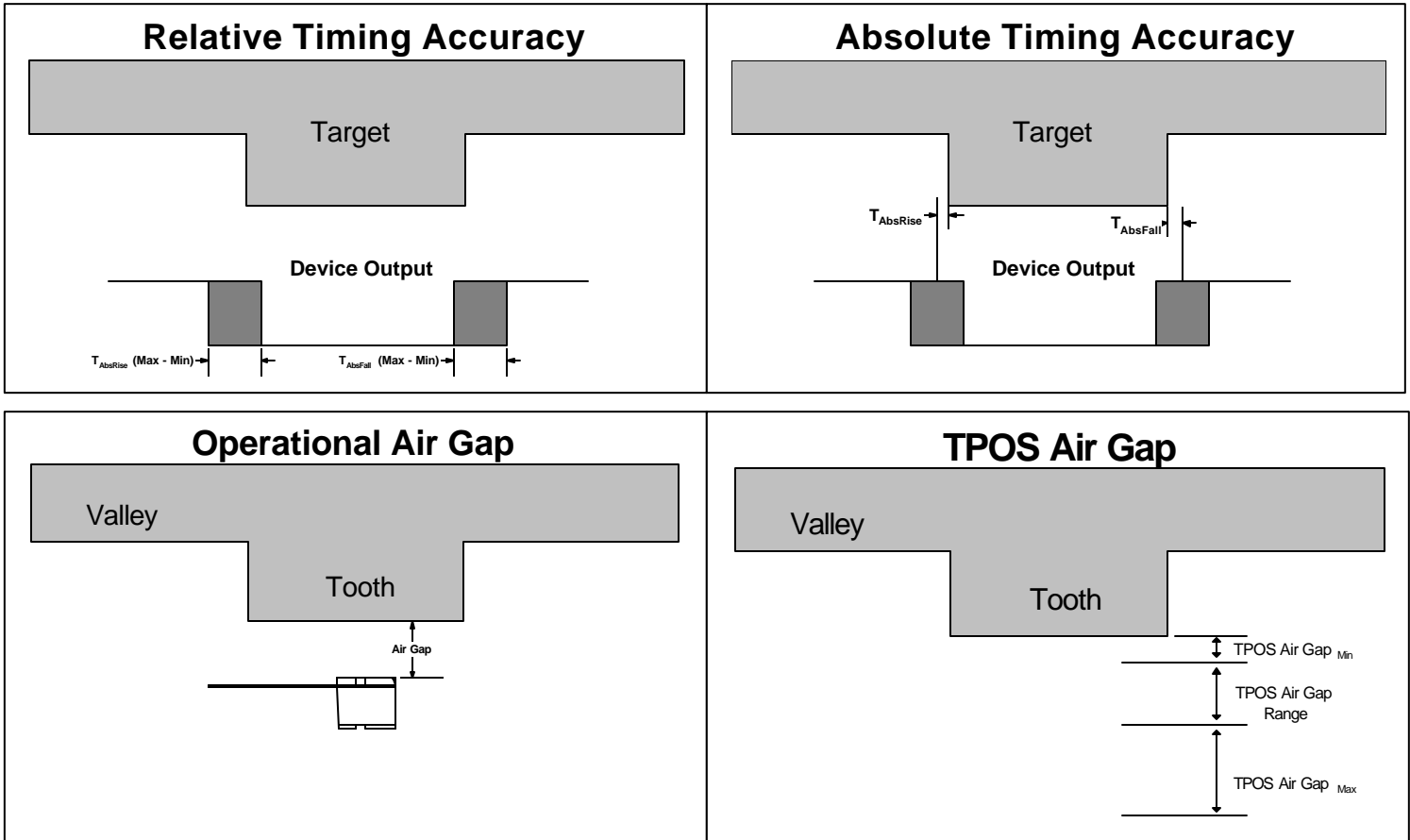

Rise and Fall Time

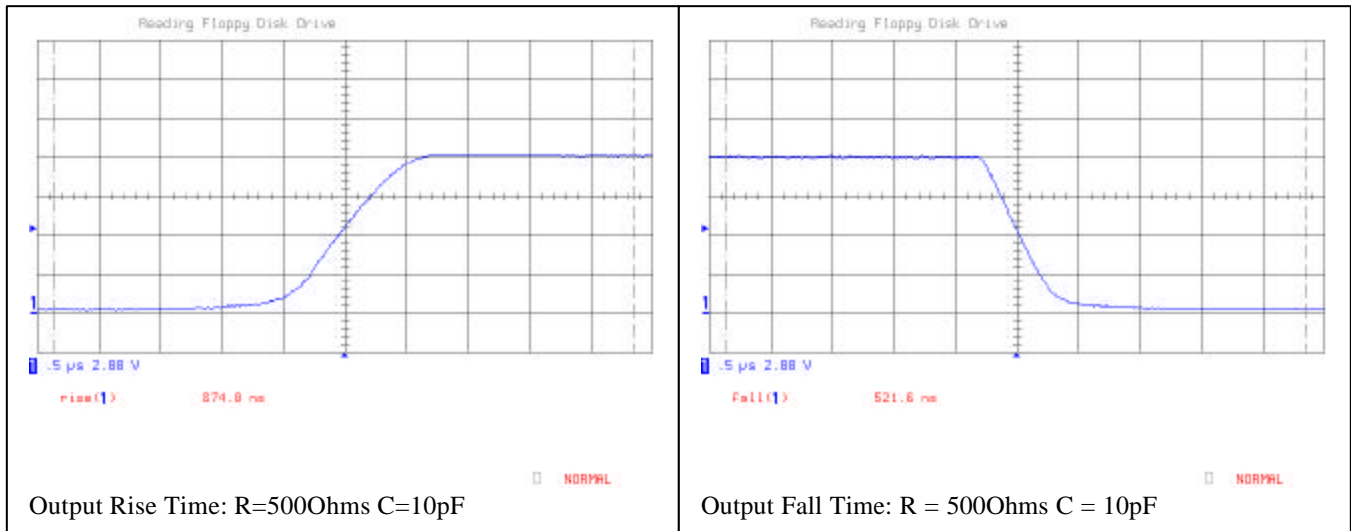

ATS671LSE
SELF CALIBRATING TPOS GEAR TOOTH SENSOR WITH 9BIT SIGNAL CAPTURE
Preliminary – Subject to Change

Reference Target Dimensions

Target	Diameter (D _o)	Thickness (F)	Tooth Width (T) 22.5° (23.6mm Ø120mm)	Valley Width (P _c - T) 22.5° (23.6mm Ø120mm)	Valley Depth (h _t)
Reference Target	120mm	6mm			5mm

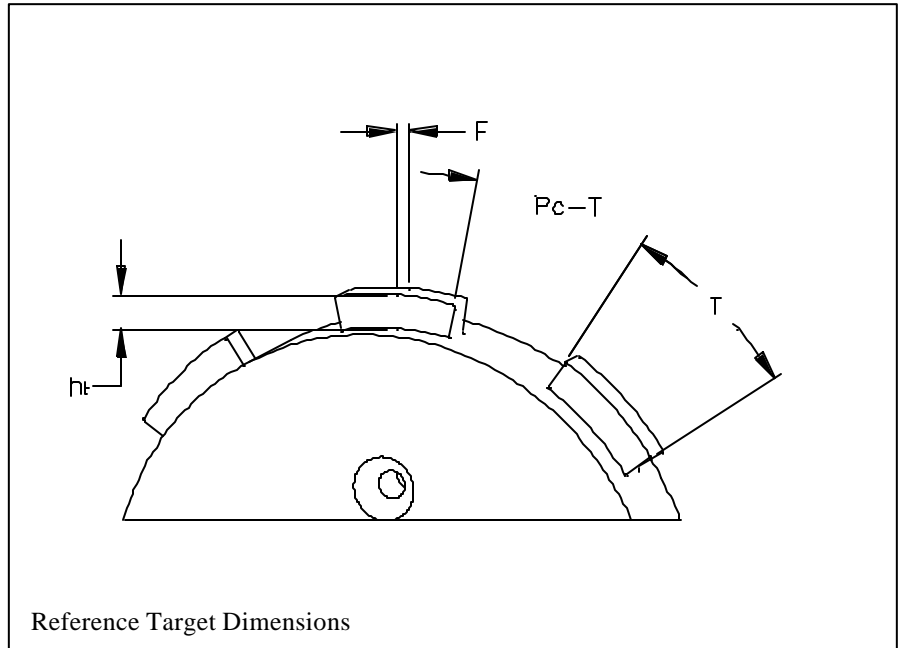
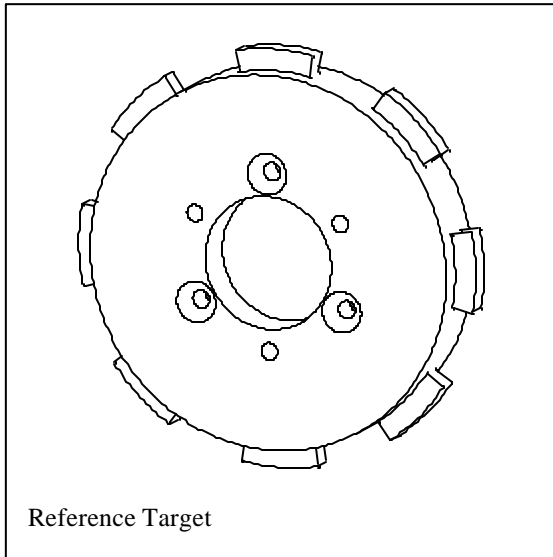

GEAR PARAMETERS FOR CORRECT TPOS OPERATION

Characteristic	Description	Limits			
		Min.	Typ.	Max.	Units
Valley Depth (h _t)	Depth of Target Valley	5	-	-	mm
Valley Width (P _c - T)	Length and Width of Target Valley	13	-	-	mm
Tooth Width (T)	Width of Target Tooth	5	-	-	mm
Thickness (F)	Thickness or Length of Target Tooth	5	-	-	mm

¹MATERIAL PROPERTIES: CRS 1018

¹ The target must generate a minimum of 120 Gauss difference between the tooth field and the valley field at the Maximum Installation Air Gap. With the material and dimensions mentioned above the target will generate the required 120 Gauss.

ATS671LSE
SELF CALIBRATING TPOS GEAR TOOTH SENSOR WITH 9BIT SIGNAL CAPTURE
Preliminary – Subject to Change

MECHANICAL INFORMATION

Component	Material	Function	Value
Sensor Package Material	SmCo – R22		8mmDx4mml
	Thermoset Epoxy	Max. Temperature	170°C ¹
Leads	Copper, 0.016" dia, 0.050" spacing		
Lead Coating	Solder, Tin / Lead 90/10 ²		

¹ Temperature excursions of up to 225°C for 2 mins or less are permitted.

² All industry accepted soldering techniques are acceptable for this sub-assembly as long as the indicated maximum temperatures for each component are not exceeded.

DEVICE QUALIFICATION PROGRAM

Test Name	Test Conditions	Test Length	# of Lots	Sample / lot	Comments
Pre/Post Test	Ta = room, hot, cold				
High Temperature Operating Life (HTOL)	Ta = 150°C, Tj = 170°C	408 hrs	1	77	JESD22-A108
High Temperature Bake (HTB)	Ta = 170°C	1000 hrs	1	77	JESD22-A103
Pre Conditioning (PC)	85°C/85%RH	168 hrs	1	231	JESD22-A112 & A113
Temperature Humidity Bias (THB) or HAST	85°C/85%RH 130°C/85%RH	1000 hrs 50 hrs	1	77	JESD22-A101 JESD22-A110
Autoclave (AC)	121°C/15 psig	96 hrs	1	77	JESD22-A102
Temperature Cycle (TC)	-65°C to +150°C	500 cycles	1	77	JESD22-A104
	or -50°C to +150°C	1000 cycles			
External Visual (EV)					
Physical Dimensions (PD)			1	30	
Lead Integrity			1	45	
Bond Pull Strength			1	30	
ESD	HBM & MM		1	3 per model per V step	JESD22-A114 & A115, CDF-AEC-Q100-002, 003 & 011
Solderability (SD)			1	15	JESD22-B102
Early Life Failure Rate (ELFR)	125°C	48 hrs	1	800	JESD22-A108
	or 150°C	24 hrs			
Gate Leakage (GL)			1	6	CDF- AEC-Q100-006
Electrical Distributions (ED)	Ta = room, hot, cold		3	30	

ATS671LSE
SELF CALIBRATING TPOS GEAR TOOTH SENSOR WITH 9BIT SIGNAL CAPTURE
 Preliminary – Subject to Change

Function Block Diagram

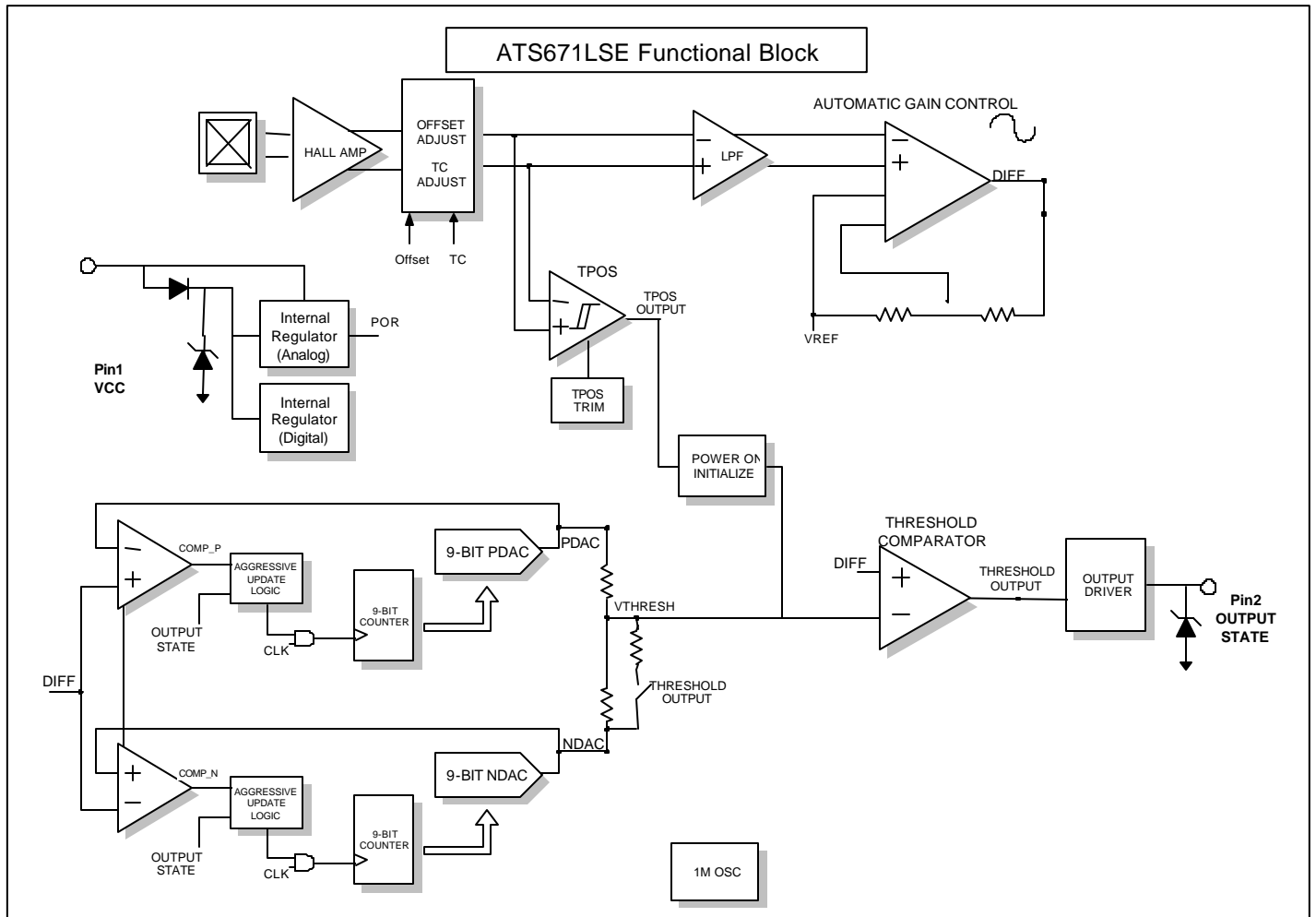

ELECTROMAGNETIC CAPABILITY (EMC) PERFORMANCE

Please contact Allegro MicroSystems for EMC performance

Test Name	Reference Specification
ESD – Human Body Model	AEC-Q100-002
ESD – Machine Model	AEC-Q100-003
Conducted Transients	ISO 7637-1
Direct RF Injection	ISO 11452-7
Bulk Current Injection	ISO 11452-4
TEM Cell	ISO 11452-3

ATS671LSE
SELF CALIBRATING TPOS GEAR TOOTH SENSOR WITH 9BIT SIGNAL CAPTURE
 Preliminary – Subject to Change

Timing Accuracy vs. Air Gap Over Temperature:

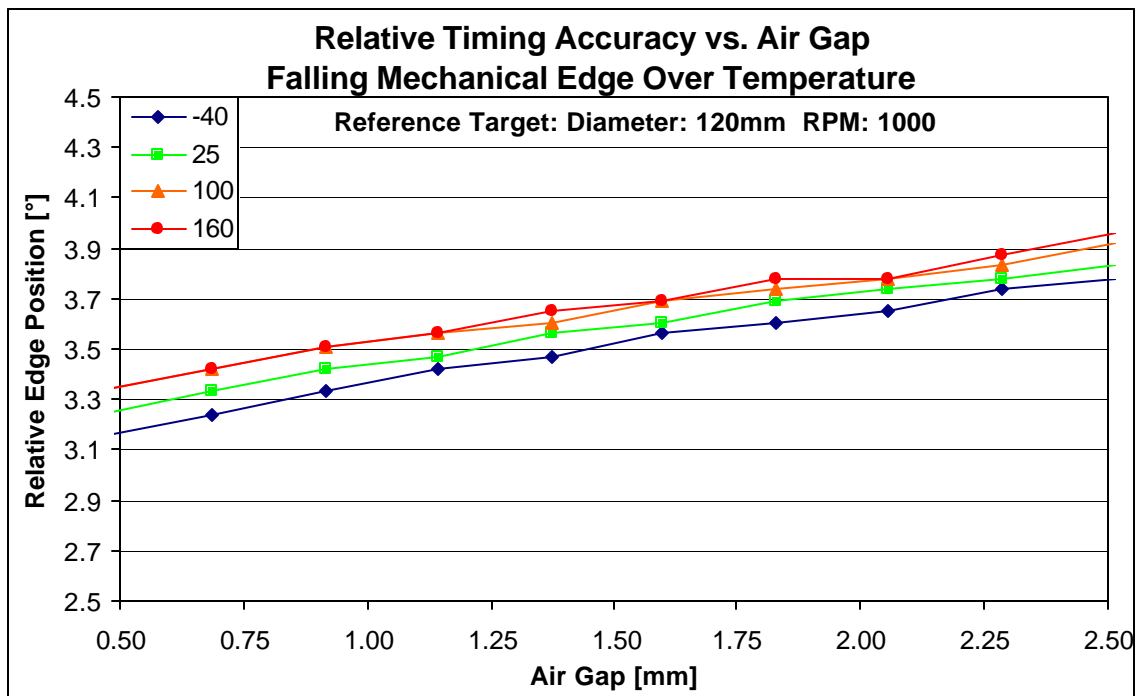
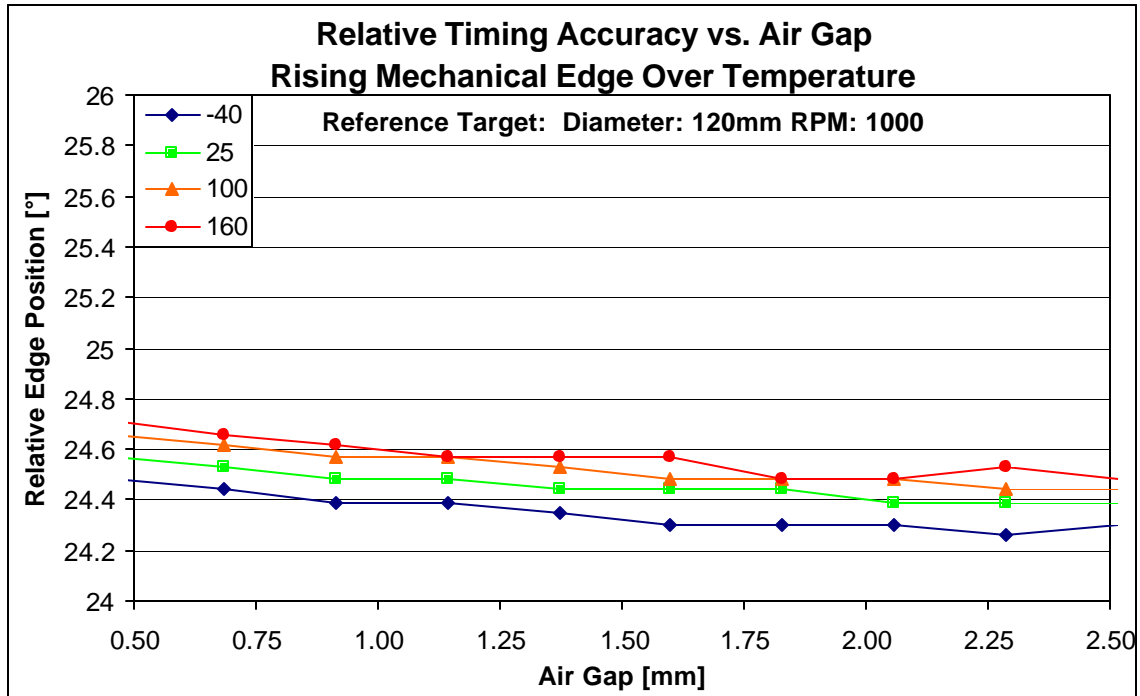

Power De-Rating Curve: ATS671LSE Package

Power De-Rating

Due to internal power consumption, the temperature of the IC (junction temperature, T_j) is higher than the ambient environment temperature, T_a . To ensure that the device does not operate above the maximum rated junction temperature use the following calculations:

$$\Delta T = P_D * R_{\theta ja}$$

$$\text{Where } P_D = V_{cc} * I_{cc}$$

$$\therefore \Delta T = V_{cc} * I_{cc} * R_{\theta ja}$$

Where ΔT denotes the temperature rise resulting from the IC's power dissipation:

$$T_j = T_a + \Delta T \quad R_{\theta ja} = 103^\circ\text{C/W} \quad T_j(\text{max}) = 170^\circ\text{C}$$

Typical T_j Calculation:

$$T_a = 25^\circ\text{C}, V_{cc} = 5\text{V}, I_{cc}(\text{On}) = 6.5\text{mA}$$

$$P_D = V_{cc} * I_{cc}$$

$$P_D = 5\text{V} * 6.5\text{mA} = 32.5\text{mW}$$

$$\Delta T = P_D * R_{\theta ja} = 32.5\text{mW} * 103^\circ\text{C/W} = 3.35^\circ$$

$$T_j = T_a + \Delta T = 25^\circ\text{C} + 3.35^\circ\text{C} = 28.35^\circ\text{C}$$

Maximum Allowable Power Dissipation Calculation

$$T_j = T_a + \Delta T$$

$$T_j(\text{max}) = 170^\circ\text{C}, \text{ if } T_a = 160^\circ\text{C} \text{ then:}$$

$$170 = 160 + \Delta T$$

$$\Delta T = 10^\circ\text{C}$$

$$\Delta T = P_D * R_{\theta ja} \quad (R_{\theta ja} = 103^\circ\text{C/W})$$

$$\therefore P_{D(\text{max})} = 10^\circ\text{C} / 103^\circ\text{C/W} = 97.1\text{mW} @ T_a = 160^\circ\text{C}$$

Maximum V_{cc} for $P_{D(\text{max})} = 111\text{mW}$ at $T_a = 160^\circ\text{C}$

$$P_D = V_{cc} * I_{cc} \quad I_{cc} = 10\text{mA} (\text{max}) \text{ at } 160^\circ\text{C}$$

$$V_{cc} = P_D / I_{cc} = 97.1\text{mW} / 10\text{mA} = 9.71\text{Volts}$$

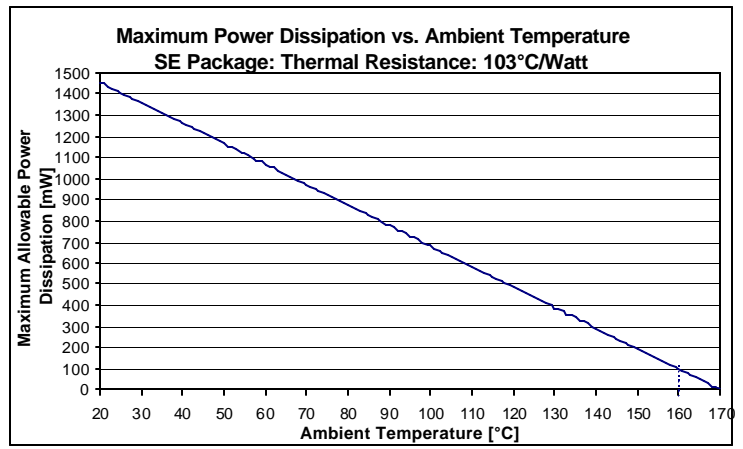

ATS671LSE
SELF CALIBRATING TPOS GEAR TOOTH SENSOR WITH 9BIT SIGNAL CAPTURE
 Preliminary – Subject to Change

SE Package Drawing

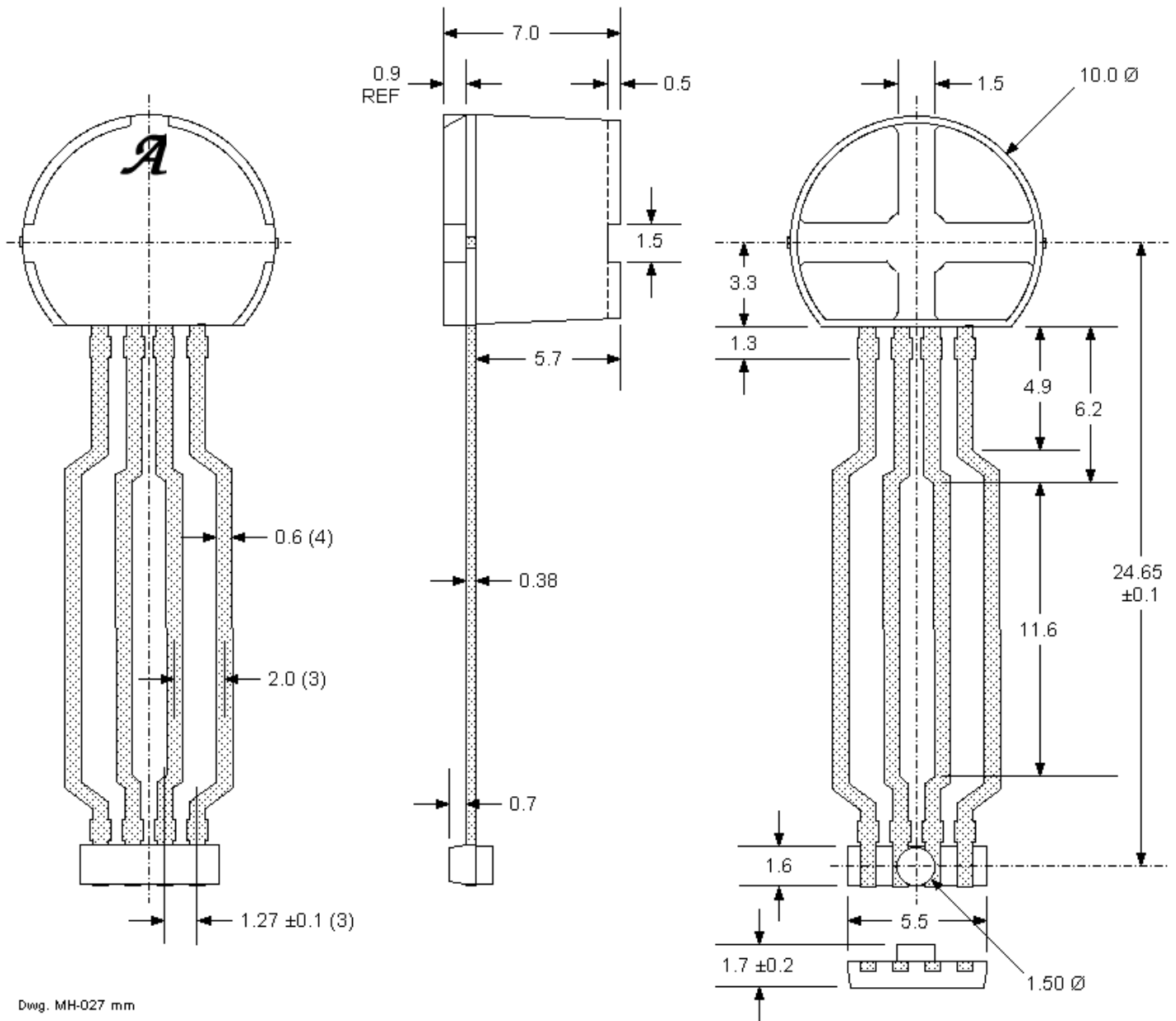

Tolerances Unless Otherwise specified: 1 place +0.1mm, 2 places +0.05mm