

- NOTES:
1. ALL DIMENSION IN MM [INCH]
 2. GENERAL TOLERANCE: X.X=±0.4
X.XX=±0.25
 3. TERM. NOS. FOR REF. ONLY
 4. CONTACT RATING SWITCHING: 150mA, 250V AC/DC
350mA, 110V AC/DC
 5. CONTACT RATING (NON-SWITCHING) 5A
 6. OPERATING FORCE: 425±100 CM/STANDARD
 7. OPERATING TEMP: -30° to 85°C
 - ▲ 8. CIRCUIT 3Pole: 12 POSITIONS, 30° INDEX.
 - ▲ 9. DIELECTRIC STRENGTH 1000V RMS min. @ SEA LEVEL
 - ▲ 10. DESIGNATE MAJOR DIMENSIONS
 - ▲ 11. STOP RING, LOCK NUT AND WASHER NOT SHOWN.

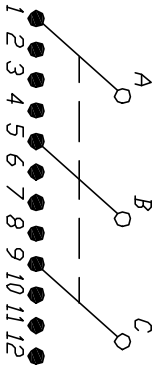

CONTACT CONFIGURATION

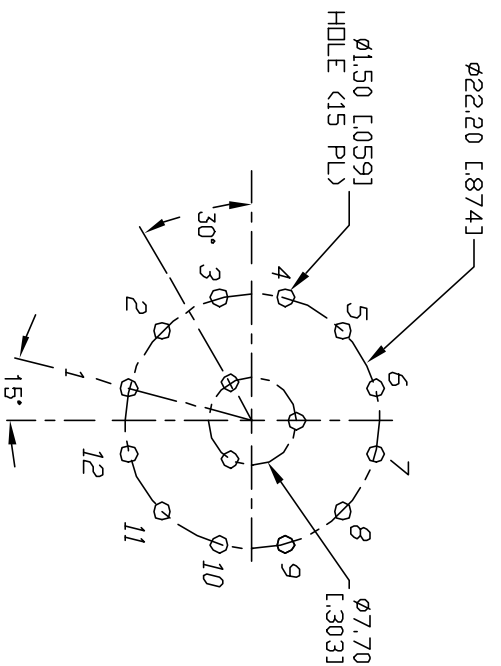

RECOMMENDED P.C.B. LAYOUT

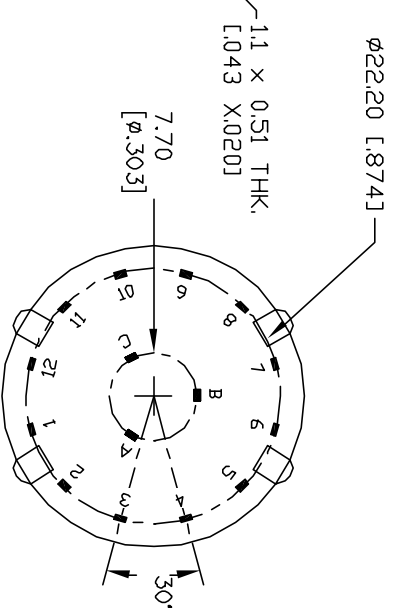
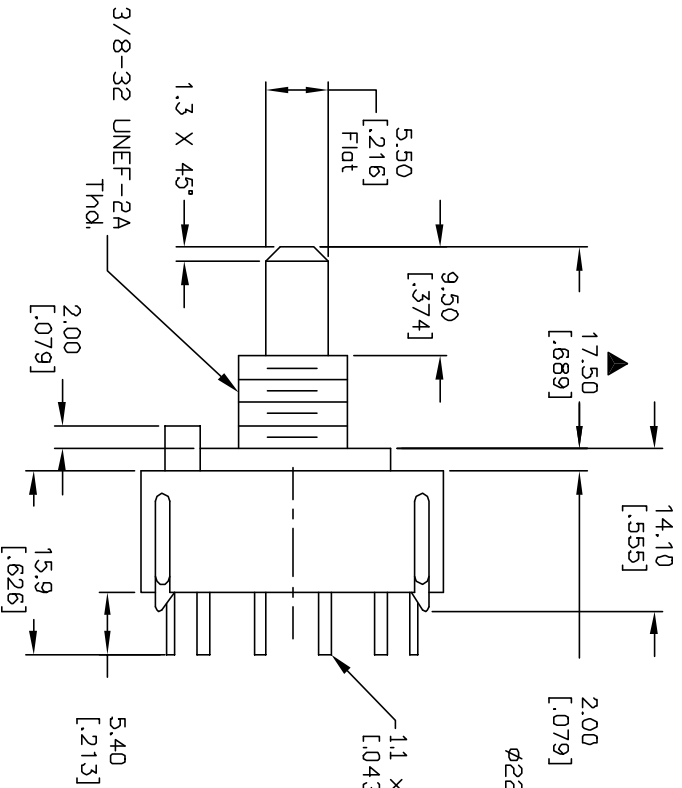
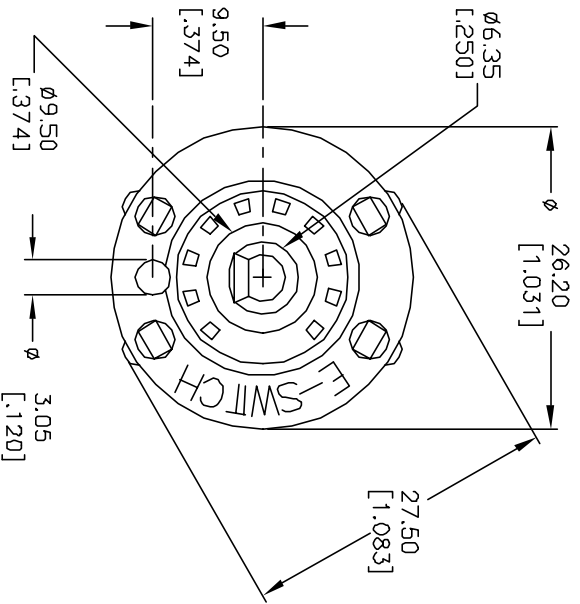

E-SWITCH®

1056W / HICKOK MOD.

REV.	ECN No.	DESCRIPTION	DATE	CHKD
A	11278	RELEASED FOR PRODUCTION	5/29/01	CJB

TITLE	SCALE	DATE	DR	DWG	REV
1056W / HICKOK MOD.	1.5:1	5/29/01	CJB	G510561	A

THE INFORMATION CONTAINED IN THIS DOCUMENT IS PROPRIETARY TO E-SWITCH AND IS NOT TO BE COPIED OR TRANSFERRED