

Am2923

Eight-Input Multiplexer

DISTINCTIVE CHARACTERISTICS

- Advanced Schottky technology
- 3-state output for bus organized systems
- Switches one of eight inputs to two complementary outputs

GENERAL DESCRIPTION

The Am2923 is an 8-input multiplexer that switches one of eight inputs onto the inverting and non-inverting outputs under the control of a 3-bit select code. The inverting output is one gate delay faster than the non-inverting output.

The Am2923 features a 3-state output for data bus organization. The active-LOW strobe, or "output control", applies to both the inverting and non-inverting output. When the output control is HIGH, the outputs are in the high-impedance state. When the output control is LOW, the active pull-up output is enabled.

BLOCK DIAGRAM

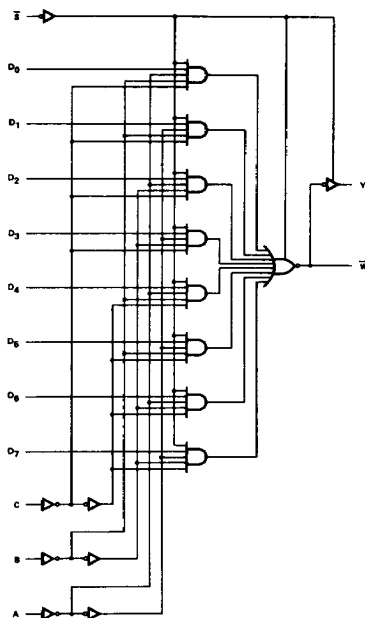

BD002360

RELATED PRODUCTS

Part No.	Description
Am2922	8 Input MUX with Register Control
Am25LS2535	8 Input MUX with Register Control

03601B

5-210

Refer to Page 13-1 for Essential Information on Military Devices

CONNECTION DIAGRAM Top View

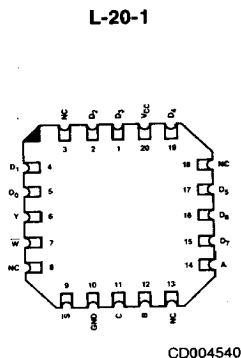
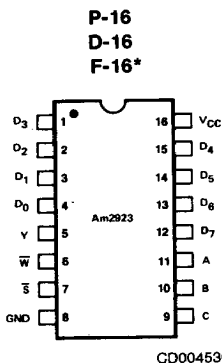

Note: Pin 1 is marked for orientation
*F-16 pin configuration identical to D-16, P-16.

5

METALLIZATION AND PAD LAYOUT

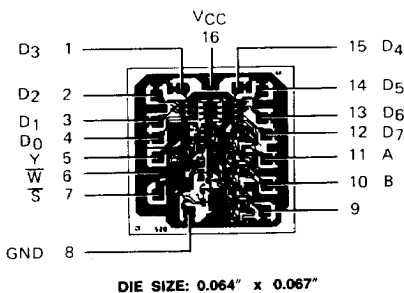

ORDERING INFORMATION

AMD products are available in several packages and operating ranges. The order number is formed by a combination of the following: Device number, speed option (if applicable), package type, operating range and screening option (if desired).

Am2923

D

C

B

Screening Option
Blank - Standard processing
B - Burn-in

Temperature (See Operating Range)
C - Commercial (0°C to +70°C)
M - Military (-55°C to +125°C)

Package
D - 16-pin Cerdip
F - 16-pin flatpak
L - 20-pin leadless chip carrier
P - 16-pin plastic DIP
X - Dice

Device type
8-Input Multiplexer

Valid Combinations	
Am2923	PC DC, DCB, DM, DMB FM, FMB LC, LCB, LM, LMB XC, XM

Valid Combinations
Consult the AMD sales office in your area to determine if a device is currently available in the combination you wish.

PIN DESCRIPTION

Pin No.	Name	I/O	Description
9, 10, 11	A,B,C	I	The three select inputs of the multiplexer.
	D ₀ ,D ₁ D ₂ ,D ₃ D ₄ ,D ₅ D ₆ ,D ₇	I	The eight data inputs of the multiplexer.
5	Y	O	The true multiplexer output.
6	\bar{W}	O	The complement multiplexer output.
7	\bar{S}	I	Output Control. HIGH on the output control (or strobe) forces both the \bar{W} and Y outputs to the high-impedance (off) state.

FUNCTION TABLE

INPUTS			OUTPUTS		
SELECT			Output Control S	Y	\bar{W}
C	B	A			
X	X	X	H	Z	Z
L	L	L	L	D ₀	D ₀
L	L	H	L	D ₁	D ₁
L	H	L	L	D ₂	D ₂
L	H	H	L	D ₃	D ₃
H	L	L	L	D ₄	D ₄
H	L	H	L	D ₅	D ₅
H	H	L	L	D ₆	D ₆
H	H	H	L	D ₇	D ₇

H = HIGH X = Don't Care
L = LOW Z = High Impedance
D₀-D₇ = The output will follow the HIGH-level or LOW-level of the selected input.
 \bar{D}_0 - \bar{D}_7 = The output will follow the complement of the HIGH-level or LOW-level of the selected input.

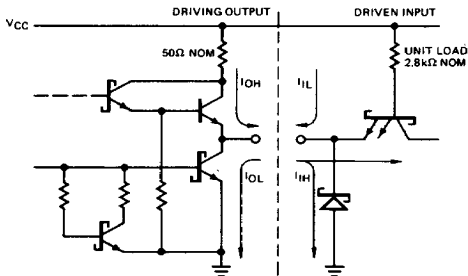
SCHOTTKY INPUT/OUTPUT
CURRENT INTERFACE CONDITIONS

IC000370

Note: Actual current flow direction shown.

LOADING RULES (In Unit Loads)

Input/ Output	Pin No.'s	Input Unit Load	Fan-out	
			Output HIGH	Output LOW
D ₃	1	1	-	-
D ₂	2	1	-	-
D ₁	3	1	-	-
D ₀	4	1	-	-
Y	5	-	20	10
\bar{W}	6	-	20	10
\bar{S}	7	1	-	-
GND	8	-	-	-
C	9	1	-	-
B	10	1	-	-
A	11	1	-	-
D ₇	12	1	-	-
D ₆	13	1	-	-
D ₅	14	1	-	-
D ₄	15	1	-	-
V _{CC}	16	-	-	-

A Schottky TTL Unit Load is defined as 50μA measured at 2.7V HIGH and -2.0mA measured at 0.5V LOW.

APPLICATIONS LOGIC FUNCTION GENERATION

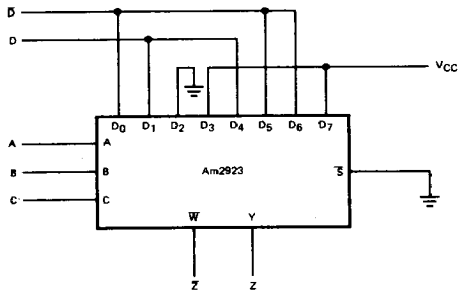

AF002060

$$Z = ABCD + ABC\bar{D} + A\bar{C}D + AB + A\bar{C}D + B\bar{C}D$$

32-INPUT MULTIPLEXER

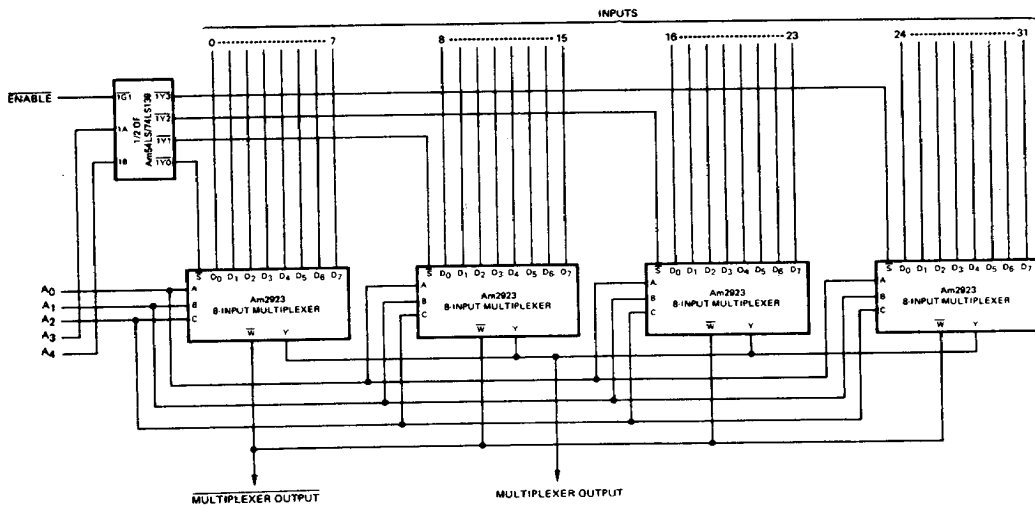

AF001690

ABSOLUTE MAXIMUM RATINGS

Storage Temperature	-65°C to +150°C
(Ambient) Temperature Under Bias	-55°C to +125°C
Supply Voltage to Ground Potential (Pin 16 to Pin 8) Continuous	-0.5V to +7.0V
DC Voltage Applied to Outputs For High Output State	-0.5V to +V _{CC} max
DC Input Voltage	-0.5V to +5.5V
DC Output Current, Into Outputs	30mA
DC Input Current	-30mA to +5.0mA

Stresses above those listed under **ABSOLUTE MAXIMUM RATINGS** may cause permanent device failure. Functionality at or above these limits is not implied. Exposure to absolute maximum ratings for extended periods may affect device reliability.

OPERATING RANGES

Commercial (C) Devices	Temperature	0°C to +70°C
	Supply Voltage	+4.75V to +5.25V
Military (M) Devices	Temperature	-55°C to +125°C
	Supply Voltage	+4.5V to +5.5V

Operating ranges define those limits over which the functionality of the device is guaranteed.

DC CHARACTERISTICS over operating range unless otherwise specified

Parameters	Description	Test Conditions (Note 1)	Min	Typ (Note 2)		Max	Units
V _{OH}	Output HIGH Voltage	V _{CC} = MIN, V _{IN} = V _{IH} or V _{IL}	MIL, I _{OH} = -2mA COM'L, I _{OH} = -6.5mA	2.4	3.4		
V _{OL}	Output LOW Voltage	V _{CC} = MIN, I _{OL} = 20mA V _{IN} = V _{IH} or V _{IL}				0.5	Volts
V _{IH}	Input HIGH Level	Guaranteed input logical HIGH voltage for all inputs		2			Volts
V _{IL}	Input LOW Level	Guaranteed input logical LOW voltage for all inputs				0.8	Volts
V _I	Input Clamp Voltage	V _{CC} = MIN, I _{IN} = -18mA				-1.2	Volts
I _{IL} (Note 3)	Unit Load Input LOW Current	V _{CC} = MAX, V _{IN} = 0.5				-2	mA
I _{IH} (Note 3)	Unit Load Input HIGH Current	V _{CC} = MAX, V _{IN} = 2.7				50	μA
I _I	Input HIGH Current	V _{CC} = MAX, V _{IN} = 5.5V				1	mA
I _{O(off)}	Off-State (High-Impedance) Output Current	V _{CC} = MAX, V _O = 2.4V V _{IN} = V _{IH} or V _{IL} V _O = 0.5V				50 -50	μA
I _{SC}	Output Short Circuit Current (Note 4)	V _{CC} = MAX V _{OUT} = 0.0V	-40			-100	mA
I _{CC}	Power Supply Current	V _{CC} = MAX (Note 5)			55	85	mA

- Notes: 1. For conditions shown as MIN or MAX, use the appropriate value specified under Operating Ranges for the applicable device type.
 2. Typical limits are at V_{CC} = 5.0V, 25°C ambient and maximum loading.
 3. Actual input currents = Unit Load Current x Input Load Factor (see Loading Rules).
 4. Not more than one output should be shorted at a time. Duration of the short circuit test should not exceed one second.
 5. I_{CC} is measured with all outputs open and all inputs at 4.5V.

SWITCHING CHARACTERISTICS (T_A = 25°C)

Parameters	Description	Test Conditions	Min	Typ	Max	Units	
t _{PLH}	A, B, or C to Y; 4 Levels of Delay	V _{CC} = 5.0V, R _L = 280Ω, C _L = 15pF		12	18	ns	
t _{PHL}				13	19.5		
t _{PLH}	A, B, or C to \bar{W} ; 3 Levels of Delay			10	15	ns	
t _{PHL}				9	13.5		
t _{PLH}	Any D to Y			8	12	ns	
t _{PHL}				8	12		
t _{PLH}	Any D to \bar{W}			4.5	7	ns	
t _{PHL}				4.5	7		
t _{ZH}	Output Enable to Y		V _{CC} = 5.0V, R _L = 280Ω, C _L = 15pF		13	19.5	ns
t _{ZL}					14	21	
t _{ZH}	Output Enable to \bar{W}			13	19.5	ns	
t _{ZL}				14	21		
t _{HZ}	Output Enable to Y	V _{CC} = 5.0V, R _L = 280Ω, C _L = 5pF			5.5	8.5	ns
t _{LZ}					9	14	
t _{HZ}	Output Enable to \bar{W}			5.5	8.5	ns	
t _{LZ}				9	14		