

TAT7460

75 Ω 5V 50-2600MHz RF Amplifier



Applications

- Distribution Amplifiers
- Multi-Dwelling Units
- Drop Amplifiers
- Single-ended Gain Block
- FTTH Receivers



SOT-89 package

Product Features

- 50-2600 MHz bandwidth
- Low Noise Figure: 2.4 dB up to 1600 MHz
- Extremely Flat Gain Response
- Low Power Consumption: 100 mA with 5 V
- SOT-89 package

Functional Block Diagram

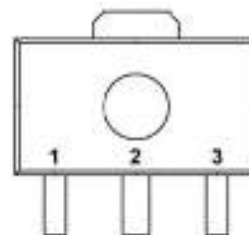

RF IN GND RFOUT

General Description

The TAT7460 is a 75 Ohm RF Amplifier designed for use up to 2600 MHz, addressing the CATV and Satellite bands in a single part. The TAT7460 is fabricated using 6-inch GaAs pHEMT technology to optimize performance and cost.

Pin Configuration

Pin #	Symbol
1	RF IN
2	GND
3	RF OUT
4	GND PADDLE

Ordering Information

Part No.	Description
TAT7460	75 Ω High linearity pHEMT amplifier <small>(lead-free/RoHS compliant SOT-89 Pkg)</small>
TAT7460-EB	Amplifier Evaluation Board

Standard T/R size = 1000 pieces on a 7" reel.

TAT7460

75 Ω 5V 50-2600MHz RF Amplifier



Specifications

Absolute Maximum Ratings¹

Parameter	Rating
Device Voltage	+10.0 V
Operating Temperature	-40 to +85 °C
Storage Temperature	-65 to +150 °C

Notes:

1. Operation of this device outside the parameter ranges given above may cause permanent damage

Recommended Operating Conditions

Parameter	Min	Typ	Max	Units
V _{DD}		5		V
I _{DD}		100	120	mA
T _J (for > 10 ⁶ hours MTTF)			150	°C

Electrical specifications are measured at specified test conditions. Specifications are not guaranteed over all recommended operating conditions.

Electrical Specifications

Test conditions unless otherwise noted: 25 °C case temperature, +5 V V_{DD}

Parameter	Conditions	Min	Typical	Max	Units
Operational Frequency Range		50		2600	MHz
Gain			16.5		dB
Gain Flatness			+/- 0.5		dB
Noise Figure	See Note 1		2.5		dB
Input Return Loss			18		dB
Output Return Loss			18		dB
CSO	See Note 2.		-61		dBc
CTB	See Note 2.		-72		dBc
XMOD	See Note 2.		-71		
Output IP2	See Note 3.		58		dBm
Output IP3	See Note 3.		36		dBm
P1dB			20.5		dBm
V _{SUPPLY}			+5		V
I _{DD}			100	120	mA
Thermal Resistance (jnt to case) θ_{jc}			51		°C/W

Notes:

1. Up to 1600 MHz
2. 30 dBmV/ch at output, 80 ch flat
3. 5 dBm/tone output with 100 MHz tone spacing

TAT7460

75 Ω 5V 50-2600MHz RF Amplifier



Application Circuit Reference Design 50-2600 MHz

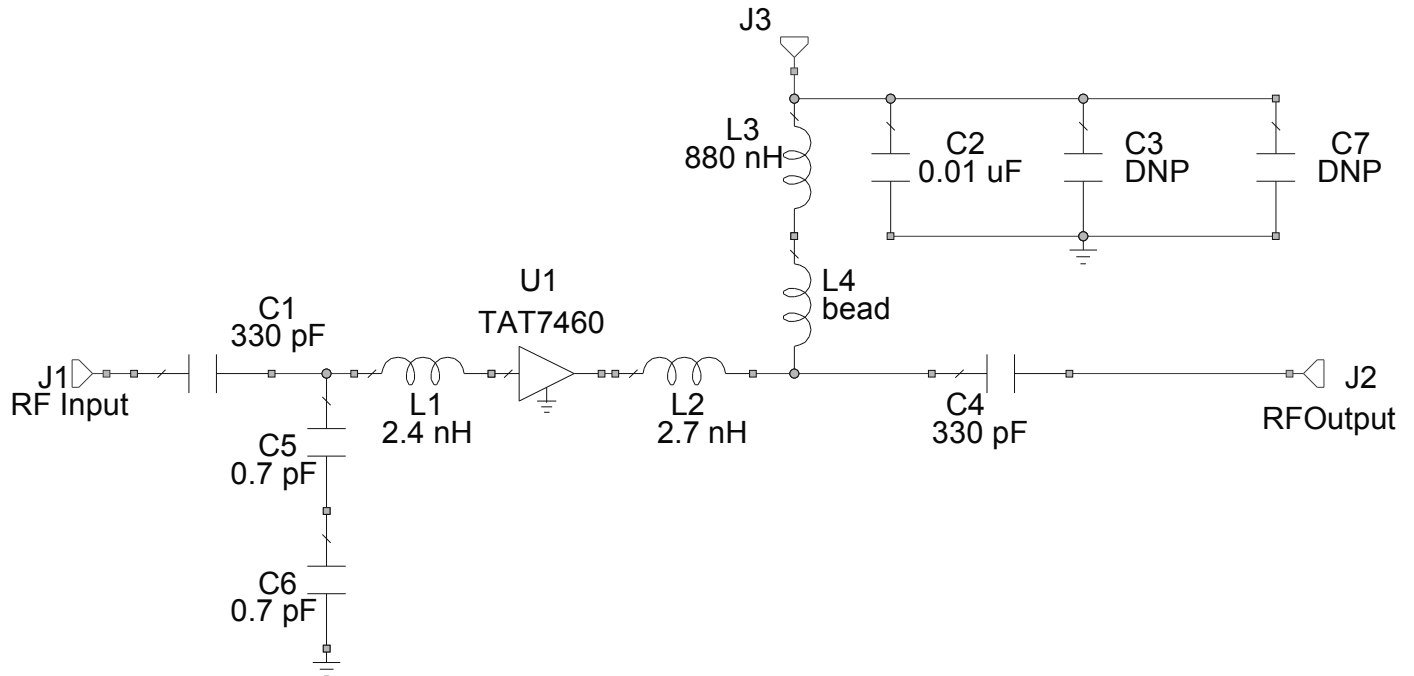

Application Circuit BOM 50-2600 MHz

Bill of Material

Ref. Desg.	Value	Description	Manufacturer	Part Number
U1		75 Ω pHEMT Amplifier	TriQuint	TAT7460
C1, C4	330 pF	Ceramic Cap, 0402, 50 V, 5%	Various	
C5, C6	0.7 pF	Ceramic Cap, 0402, 50 V, ±0.1 pF	Various	
C2	0.01 uF	Ceramic Cap, 0402, X7R, 16 V, 5 %	Various	
L1	2.4 nH	Wirewound Ind, 0402, 5%	Various	
L2	2.7 nH	Wirewound Ind, 0402, 5%	Various	
L3	880 nH	Wirewound Ind, 1206, 5%	Various	
L4	Bead	Ferrite Bead, 0402, 200 mA, 1.0 Ω	Murata	BLM15AG102SN1
R1	0 Ω	Thick Film Res, 1206	Various	
J1, J2	Connector	F-Connector	Various	
J3	Header	Header Connector	Various	
C3, C7	DNP	Do Not Place Part		

TAT7460

75 Ω 5V 50-2600MHz RF Amplifier



Application Board Layout

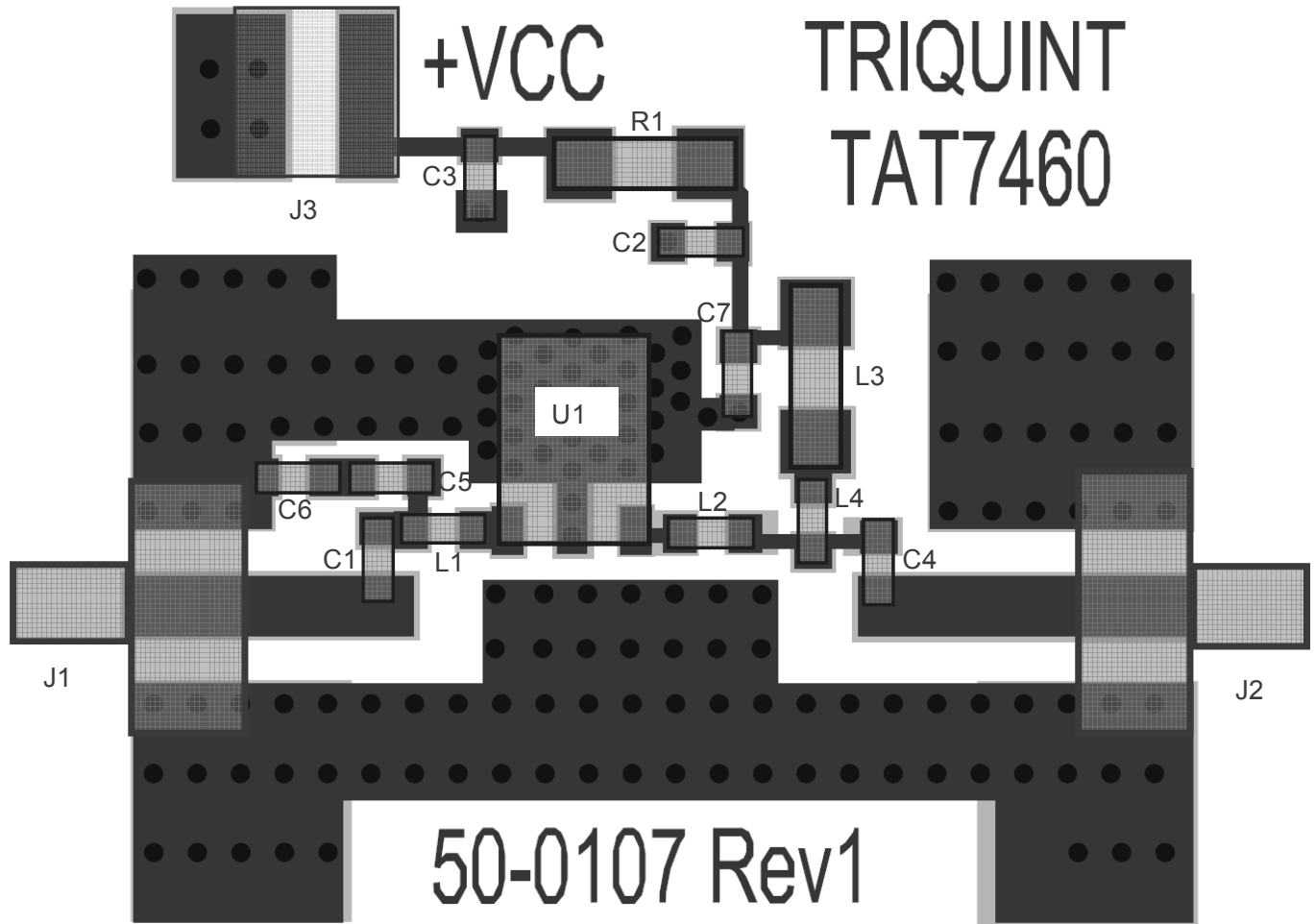

TAT7460

75 Ω 5V 50-2600MHz RF Amplifier



Application Board Typical Performance

$V_{DD} = +5\text{ V}$, $I_{DD} = 100\text{ mA}$, temperatures measured at the case of the device

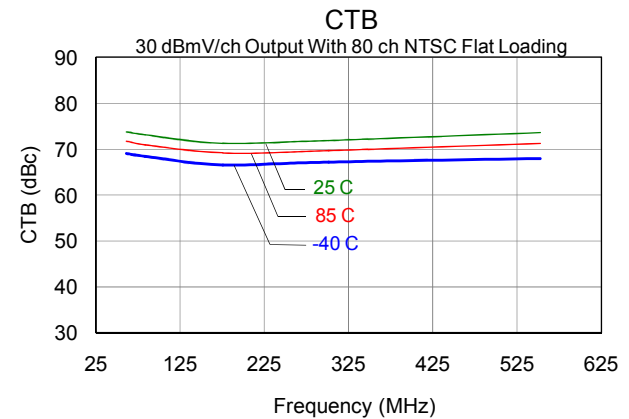
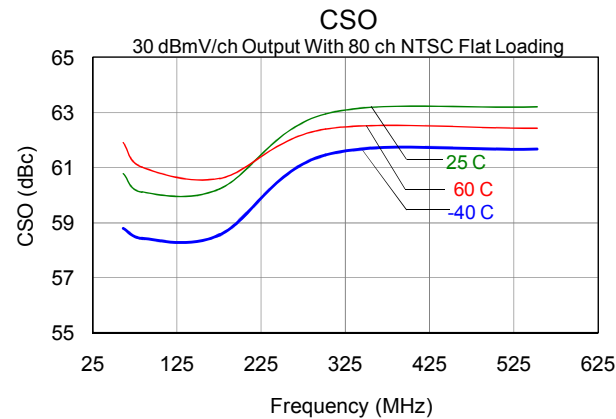
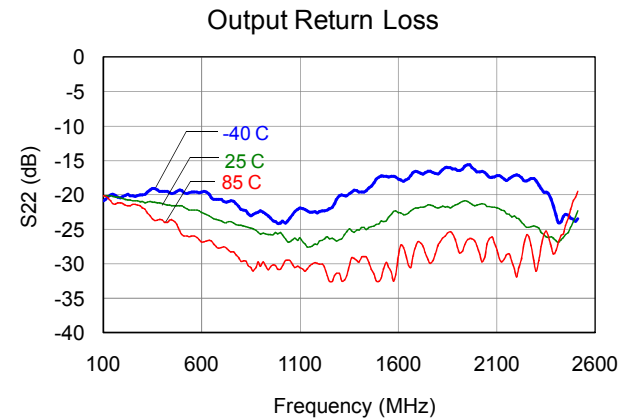
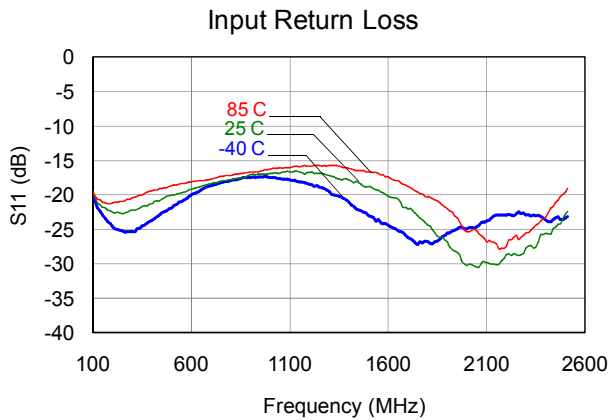
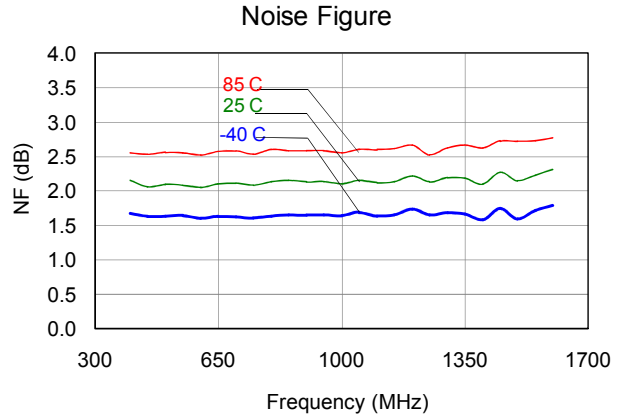
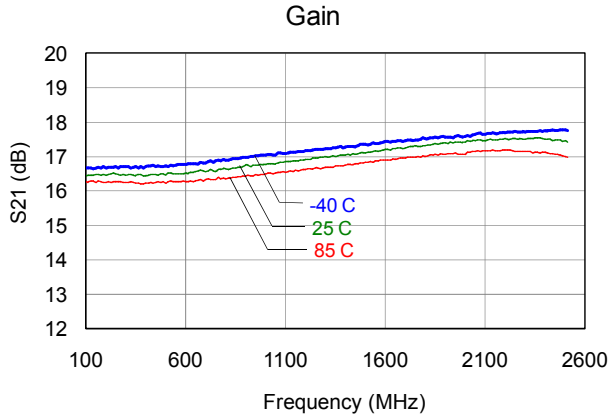

TAT7460

75 Ω 5V 50-2600MHz RF Amplifier



Application Board Typical Performance (continued)

$V_{DD} = +5\text{ V}$, $I_{DD} = 100\text{ mA}$, temperatures measured at the case of the device

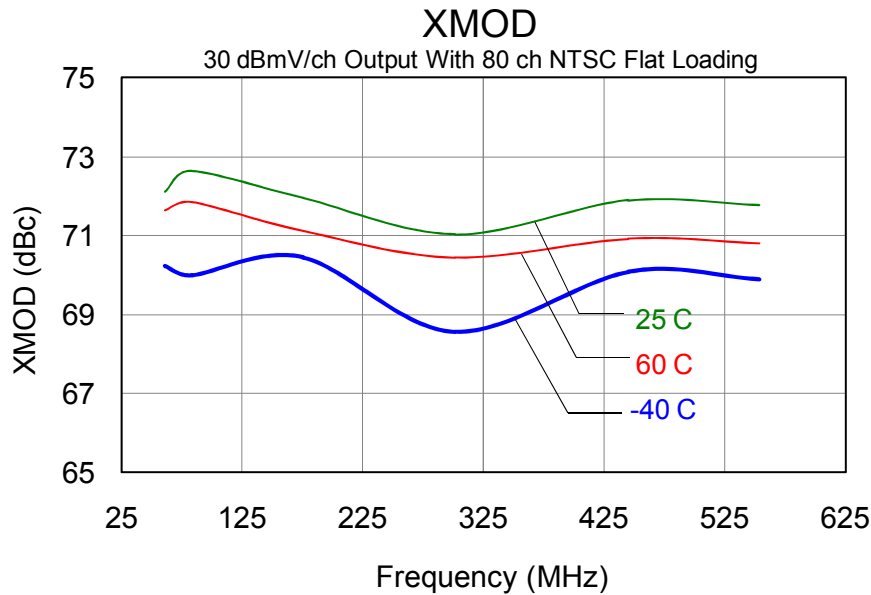

Mechanical Information

Package Information and Dimensions

This package is lead-free/RoHS-compliant. The plating material on the leads is 100% Matte Tin. It is compatible with both lead-free (maximum 260 °C reflow temperature) and lead (maximum 245 °C reflow temperature) soldering processes.

The TAT7460 will be marked with a “TAT7460” designator and an 8 digit alphanumeric lot code (XXXXYYWW). The first four digits are the lot code (XXXX). The last four digits are a date code consisting of the year and work week (YYWW) of assembly.

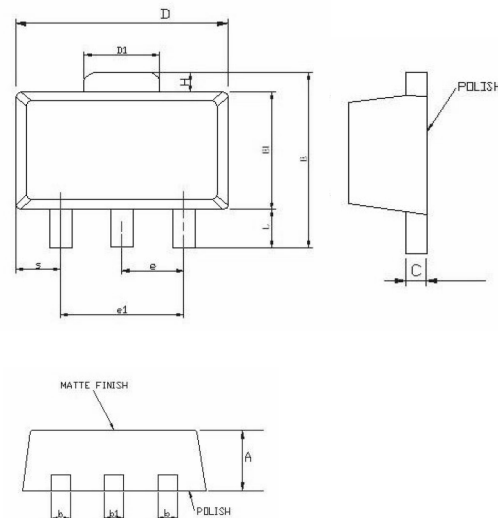

SYMBOLS	DIMENSIONS IN MILLIMETERS			DIMENSIONS IN INCHES		
	MIN	NOM	MAX	MIN	NOM	MAX
A	1.40	1.50	1.60	0.055	0.059	0.063
L	0.89	1.04	1.20	0.0350	0.041	0.047
b	0.36	0.42	0.48	0.014	0.016	0.018
b1	0.41	0.47	0.53	0.016	0.018	0.020
C	0.38	0.40	0.43	0.014	0.015	0.017
D	4.40	4.50	4.60	0.173	0.177	0.181
D1	1.40	1.60	1.75	0.055	0.062	0.069
E	3.64	—	4.25	0.143	—	0.167
E1	2.40	2.50	2.60	0.094	0.098	0.102
e1	2.90	3.00	3.10	0.114	0.118	0.122
H	0.35	0.40	0.45	0.014	0.016	0.018
S	0.65	0.75	0.85	0.026	0.030	0.034
e	1.40	1.50	1.60	0.054	0.059	0.063

TAT7460

75 Ω 5V 50-2600MHz RF Amplifier



Mounting Configuration

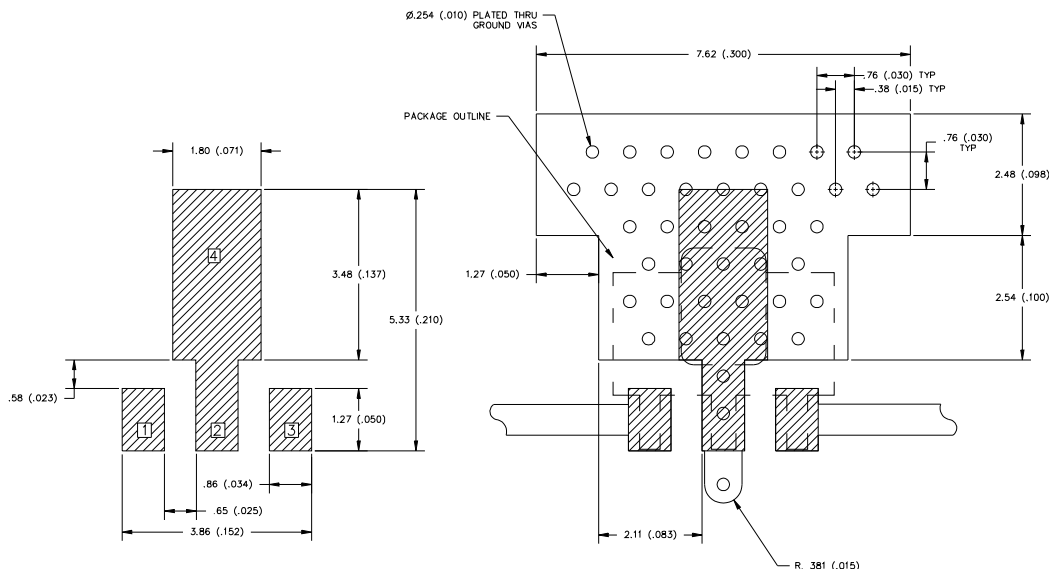

Notes:

1. Ground / thermal vias are critical for the proper performance of this device. Vias should use a .35 mm (#80/.0135") diameter drill and have a final, plated thru diameter of .25 mm (.010").
2. Add as much copper as possible to inner and outer layers near the part to ensure optimal thermal performance.
3. RF trace width depends upon the PC board material and construction.
4. All dimensions are in millimeters (inches). Angles are in degrees.

Product Compliance Information

ESD Information



Caution! ESD-Sensitive Device

ESD Rating: Class 1A+
Value: Passes ≥ 450 V min.
Test: Human Body Model (HBM)
Standard: JEDEC Standard JESD22-A114

ESD Rating: Class IV
Value: Passes ≥ 1000 V min.
Test: Charged Device Model (CDM)
Standard: JEDEC Standard JESD22-C101

MSL Rating

Level 3 at +260 °C convection reflow.
The part is rated Moisture Sensitivity Level 3 at 260°C per JEDEC standard IPC/JEDEC J-STD-020.

Solderability

Compatible with the latest version of J-STD-020, Lead free solder, 260 °C.

This part is compliant with EU 2002/95/EC RoHS directive (Restrictions on the Use of Certain Hazardous Substances in Electrical and Electronic Equipment).

TAT7460

75 Ω 5V 50-2600MHz RF Amplifier



Contact Information

For the latest specifications, additional product information, worldwide sales and distribution locations, and information about TriQuint:

Web: www.triquint.com
Email: info-sales@tqs.com

Tel: +1.707.526.4498
Fax: +1.707.526.1485

For technical questions and application information:

Email: sjapplications.engineering@tqs.com

Important Notice

The information contained herein is believed to be reliable. TriQuint makes no warranties regarding the information contained herein. TriQuint assumes no responsibility or liability whatsoever for any of the information contained herein. TriQuint assumes no responsibility or liability whatsoever for the use of the information contained herein. The information contained herein is provided "AS IS, WHERE IS" and with all faults, and the entire risk associated with such information is entirely with the user. All information contained herein is subject to change without notice. Customers should obtain and verify the latest relevant information before placing orders for TriQuint products. The information contained herein or any use of such information does not grant, explicitly or implicitly, to any party any patent rights, licenses, or any other intellectual property rights, whether with regard to such information itself or anything described by such information.

TriQuint products are not warranted or authorized for use as critical components in medical, life-saving, or life-sustaining applications, or other applications where a failure would reasonably be expected to cause severe personal injury or death.