

Introduction

The AAT1106 Evaluation Board contains a fully tested 600mA, 1.5MHz Step-Down DC/DC Regulator. The circuit has an input voltage range of 2.5V to 5.5V and four preset selectable outputs (1.2V, 1.5V, 1.8V and 2.5V). The device is capable of delivering up to 600mA of output current with a 3.0V VIN. The circuit can provide up to 96% efficiency and it consumes less than 1uA in shutdown mode. In light load mode operation there is very low output ripple voltage for noise sensitive applications. The AAT1106 comes in a small 5-pin TSOT23 package and the board has been optimized to fit small form factor designs. An optional TVS (SM6T6V8A) is connected between VIN and GND so that the evaluation board can be used in a hot-plug application. These features, plus the nominal operating frequency of 1.5MHz allowing the use of low profile surface mount components, make the AAT1106 evaluation board an ideal circuit for use in battery-powered, hand-held applications.

Board Picture

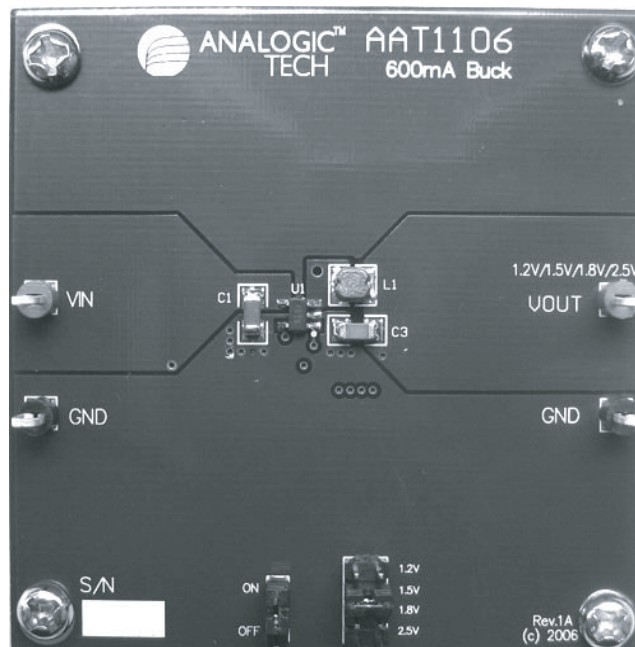

Figure 1: AAT1106 Evaluation Board.

Layout Guidelines

The following guidelines should be followed to ensure proper operation of the AAT1106:

1. The power traces, including the GND trace, LX-to-L1, L1-to-VOUT traces and the VIN-to-IN trace should be kept short, direct and wide to allow large current flow. Put many multiple-layer VIA pads when connecting traces between layers.
2. Connect the input capacitor C1 to the IN pin as close as possible to get good power filtering.
3. Keep the switching node, LX pin 3, away from the sensitive FB/OUT node.

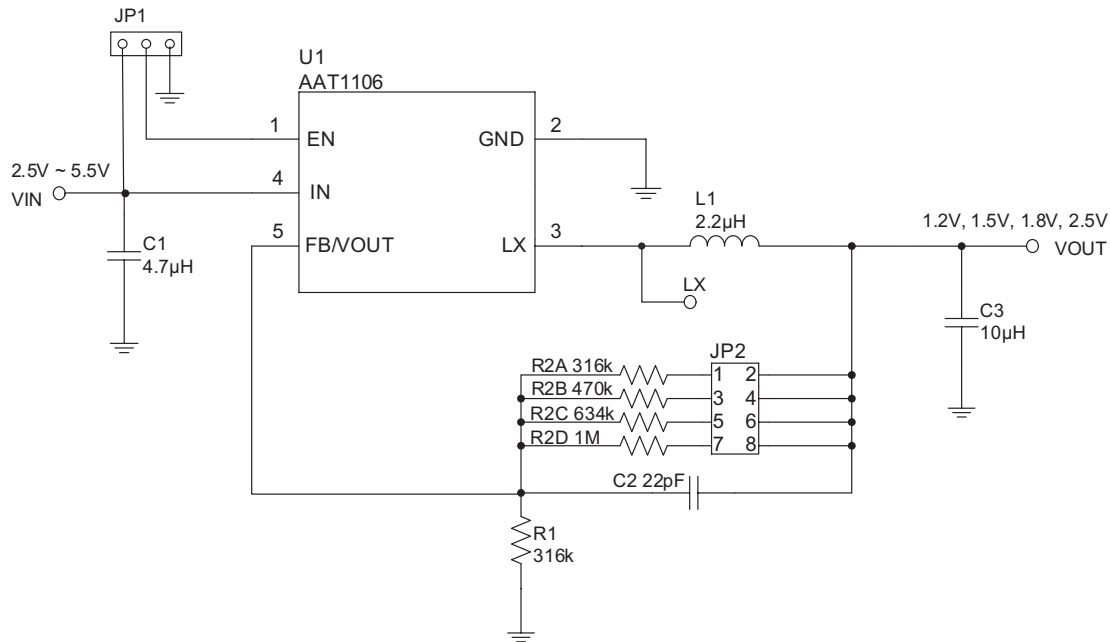

Figure 2: AAT1106 Evaluation Board Schematic.

Specification	Test Conditions	Min	Typ	Max	Units
Input Voltage		2.5	3.6	5.5	V
Output Error Voltage		-3		+3	%
Output Current		0		600	mA

Table 1: AAT1106 Evaluation Board Specifications.

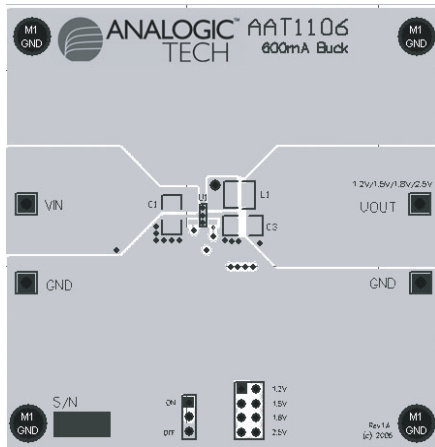

Figure 3: AAT1106 Evaluation Board PCB Top Side.

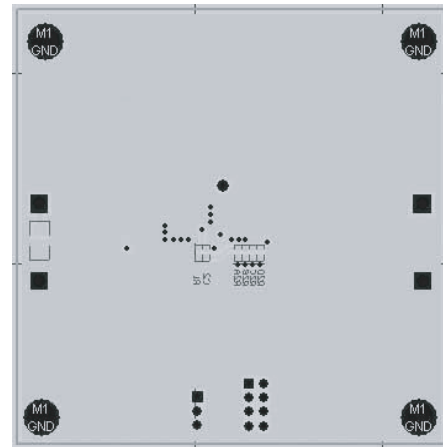

Figure 4: AAT1106 Evaluation Board PCB Bottom Side.

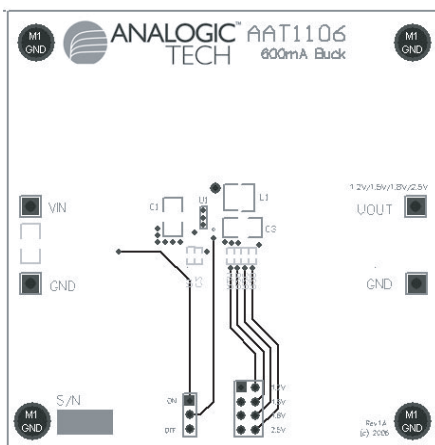

Figure 5: AAT1106 Evaluation Board PCB Midlayer 1 Side.

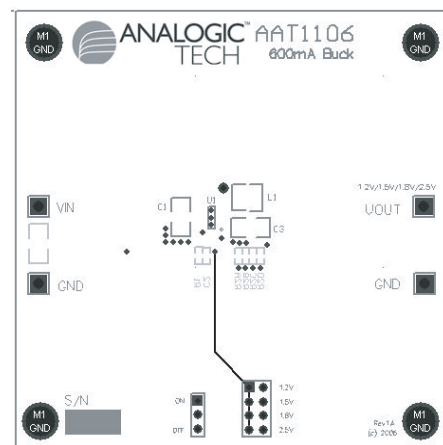

Figure 6: AAT1106 Evaluation Board PCB Midlayer 2 Side.

Test Equipment

1. 8.0V 5.0A laboratory power supply: Agilent E3648A or equivalent.
2. Electronic Load: Agilent N3301A
3. DC voltmeter: Agilent34401A or equivalent.
4. Oscilloscope: Tektronix TDS3034B or equivalent.

Setup and Test (see connection diagram in Figure 7)

A: Load and Line Regulation

1. Apply a DC power supply and DC voltmeter across input voltage terminals: VIN (positive terminal) and GND (negative terminal or return).
2. Apply a DC load and DC voltmeter to output terminals: VOUT and GND.
3. Before powering on the supply, set the FB setting jumper (JP2) to choose the VOUT voltage position (1.2V, 1.5V, 1.8V or 2.5V) and set the EN jumper (JP1) from OFF state to ON.
4. Vary the load from 0 to 600mA and the input voltage from 2.5V to 5.5V while monitoring the output voltage.
5. The output voltage as measured at the output terminals of the evaluation boards should not vary by more than $\pm 3\%$ of the nominal voltage.

B: Ripple and Shutdown Current

1. Apply a DC power supply set to 3.6V at VIN. Set the output load current between 0 mA and 600 mA, and measure the output ripple voltage; the measurement should be less than 20 mVAC.
2. Apply a DC power supply set to 4.2V at VIN. Set the jumper from ON state to OFF. Measure the shutdown supply current at this point by removing the TVS device. The TVS (SM6T6V8A) is connected between VIN and GND. The supply current will be less than 1uA in shutdown.

C: Short-Circuit Protection

1. Raise the input voltage to 5.5V.
2. Apply a short from VOUT to GND at the evaluation board terminals.
3. Remove the short and verify that the output returns to its initial value.

D: Enable Output

1. Short the EN pin to GND using JP1. The output will decay to zero.
2. Remove the short applied to the EN pin. The output will recover to its initial value.

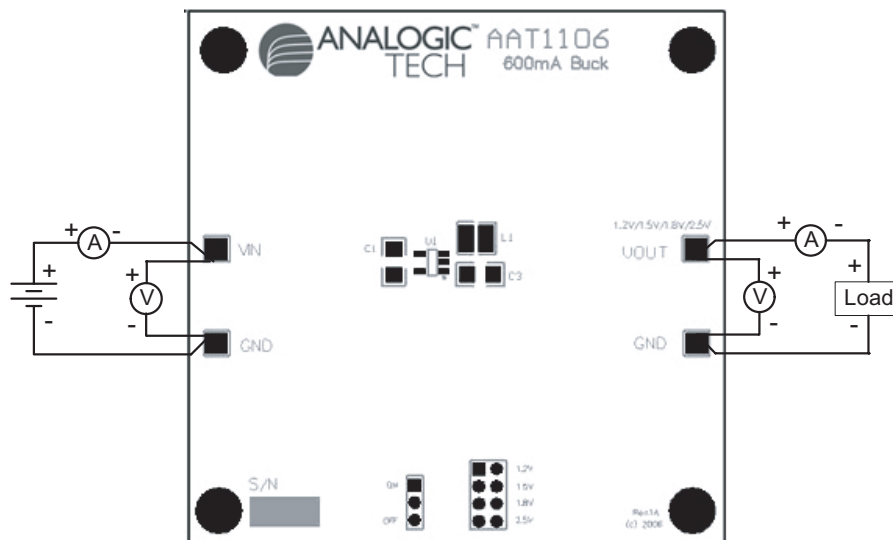
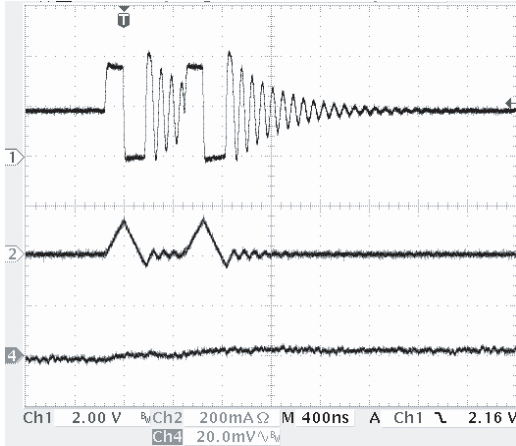

Figure 7: AAT1106 Connection Diagram.

Waveform

A: Normal Waveform



Condition: $V_{IN} = 3.6V$, $V_{OUT} = 1.8V$, No Load
 Ch1: LX, Ch2: $I_{INDUCTOR}$, Ch3: V_{OUT} (AC).

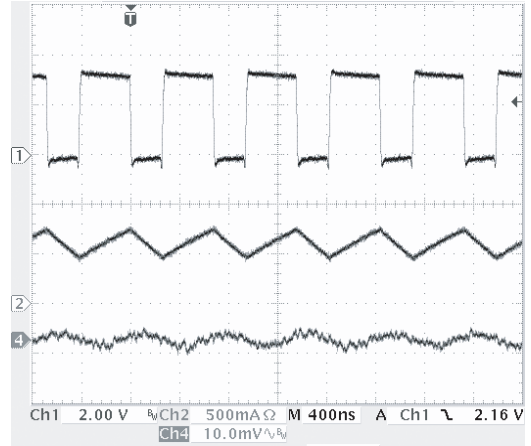

Condition: $V_{IN} = 3.6V$, $V_{OUT} = 1.8V$, 1.2A Load
 Ch1: LX, Ch2: $I_{INDUCTOR}$, Ch3: V_{OUT} (AC).

B: Startup time

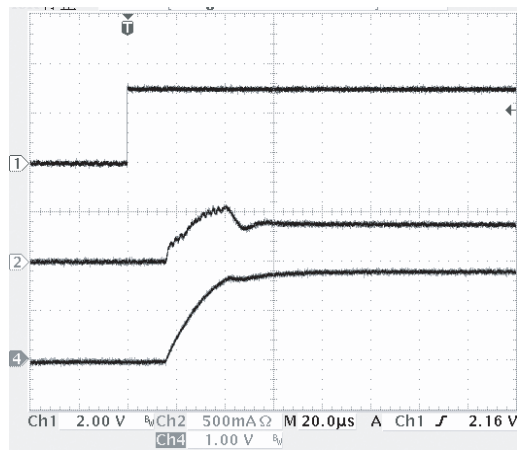

Condition: $V_{IN} = 3.6V$, $V_{OUT} = 1.8V$, 3Ω Load
 Ch1: EN, Ch2: I_{IN} , Ch3: V_{OUT} .

Component	Part Number	Description	Manufacturer
U1	AAT1106	1.5 MHz, 600mA Synchronous Step-Down Converter	Analogic Tech
L1	SF32-2R2M-R	Inductor 2.2UH 1.8A SMD	Fenfa
C1	GRM42-6X7R475K16PT	Cap Ceramic 4.7µF16V X7R 10% 1206	Murata
C2	C1005COG1H220JT000P	Cap Ceramic 22pF 50V C0G 5% 0402	TDK
C3	GRM31BR71C106KA01L	Cap Ceramic 10µF 16V X7R 10% 1206	Murata
R1, R2A	Chip Resistor	Resistor 316KΩ 1/16W 1% 0402 SMD	
R2B	Chip Resistor (optional)	Resistor 470kΩ 1/16W 1% 0402 SMD	
R2C	Chip Resistor (optional)	Resistor 634KΩ 1/16W 1% 0402 SMD	
R2D	Chip Resistor (optional)	Resistor 1MΩ 1/16W 1% 0402 SMD	
No Designator	SM6T6V8A (optional)	6.8V TVS	ST

Table 2: AAT1106 EVAL Bill of Materials.

Output Voltage

The board has an R1 value of 316kΩ. To adjust the output from the 1.8V default, select R2 according to Table 3 or use the jumper JP2. A smaller value resistor divider can be used for better noise immunity, values are shown in column 3. A larger value resistor divider is used as default for lower current consumption. Standard 1% resistor values are substituted for calculated values.

V_{OUT} (V)	R1 = 316kΩ R2 (kΩ)	R1 = 59kΩ R2 (kΩ)	V_{OUT} (V)	R1 = 316kΩ R2 (kΩ)	R1 = 59kΩ R2 (kΩ)
0.6	0(short)	0(short)	0.6	0(short)	0(short)
0.80	105	19.6	1.90	681	127
1.00	210	39.2	2.00	732	137
1.20	316	59.0	2.10	787	147
1.30	365	68.1	2.20	845	158
1.40	422	78.7	2.32	909	169
1.50	475	88.7	2.40	953	178
1.60	523	97.6	2.50	1000	187
1.70	576	107	3.30	1430	267
1.80	634	118			

Table 3: Resistor Selection for Adjustable Output Voltage.

© Advanced Analogic Technologies, Inc.

AnalogicTech cannot assume responsibility for use of any circuitry other than circuitry entirely embodied in an AnalogicTech product. No circuit patent licenses, copyrights, mask work rights, or other intellectual property rights are implied. AnalogicTech reserves the right to make changes to their products or specifications or to discontinue any product or service without notice. Except as provided in AnalogicTech's terms and conditions of sale, AnalogicTech assumes no liability whatsoever, and AnalogicTech disclaims any express or implied warranty relating to the sale and/or use of AnalogicTech products including liability or warranties relating to fitness for a particular purpose, merchantability, or infringement of any patent, copyright or other intellectual property right. In order to minimize risks associated with the customer's applications, adequate design and operating safeguards must be provided by the customer to minimize inherent or procedural hazards. Testing and other quality control techniques are utilized to the extent AnalogicTech deems necessary to support this warranty. Specific testing of all parameters of each device is not necessarily performed. AnalogicTech and the AnalogicTech logo are trademarks of Advanced Analogic Technologies Incorporated. All other brand and product names appearing in this document are registered trademarks or trademarks of their respective holders.

Advanced Analogic Technologies, Inc.
3230 Scott Boulevard, Santa Clara, CA 95054
Phone (408) 737-4600
Fax (408) 737-4611