

SMD TRANSFORMER

DRUM TYPE SURFACE MOUNT TRANSFORMER

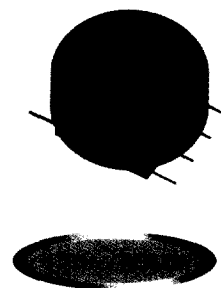

OPERATING TEMP.

-25~+85℃ (製品自己発熱含む)
(Including self-generated heat)

回路例

Equivalent circuit

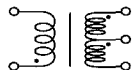
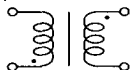

特長 FEATURES

- セットの小型、薄型化に有利
- SMT対応
- ユーザーの用途に応じた設計が可能

- Designed for applications where a surface mount component is required.
- Available in embossed tape and reel.
- This item can be custom designed to meet customer requirements

用途 APPLICATIONS

- DC-DCコンバータ用トランス
- その他一般用トランス

- A transformer for DC-DC converter.
- Other general use transformers.

形名表記法 ORDERING CODE

①

形式	
V△	コンバータトランス(非シールドタイプ)
V P	コンバータトランス(シールドタイプ)

△=スペース

②

コア寸法 (mm)	
06	6
08	8

③

形状	
DD	ドラム形(台座付き)

④

高さ寸法 (mm)		
	06タイプ	08タイプ
A	6.0max.	6.5max.
B	5.0max.	5.5max.
C	3.5max.	4.5max.

⑤

公称インダクタンス (μH)	
例	
1R0	1.0
100	10
102	1000

※R=小数点

⑥

インダクタンス許容差	
K	±10%
M	±20%
N	±30%

⑦

当社管理記号	
001~999	個別仕様

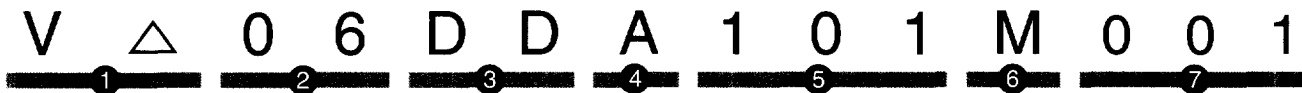

①

Type	
V△	Transformer for converter (Non-shielded type)
V P	Transformer for converter (Shielded type)

△=Blank space

②

Core dimension (mm)	
06	6
08	8

③

Shape	
DD	Drum type (With base)

④

Height (mm)		
	06type	08type
A	6.0max.	6.5max.
B	5.0max.	5.5max.
C	3.5max.	4.5max.

⑤

Nominal Inductance (μH)	
example	
1R0	1.0
100	10
102	1000

*R=decimal point

⑥

Inductance tolerance	
K	±10%
M	±20%
N	±30%

⑦

Internal code	
001~999	Product classification code

外形寸法 EXTERNAL DIMENSIONS

形式 Type	非シールド Non-shielded type						磁気シールド Shielded type		
	V 06DD			V 08DD			VP 06DD		
Fig.									
高さ記号 Height code	A	B	C	A	B	C	A	B	C
L(max)	6.5 (0.256)			8.5 (0.335)			8.7 (0.343)		
W(max)*1	8.7 (0.343)			11.8 (0.465)			8.7 (0.343)		
H(max)	6.0 (0.236)	5.0 (0.197)	3.5 (0.138)	6.5 (0.256)	5.5 (0.217)	4.5 (0.177)	6.0 (0.236)	5.0 (0.197)	3.5 (0.138)
D(typical)	0.4 (0.016)			0.5 (0.020)			0.4 (0.016)		
E(typical)	0.4 (0.016)			0.6 (0.024)			0.4 (0.016)		
P1*2	2.25±0.2 (0.089±0.008)			2.0±0.2 (0.079±0.008)			2.25±0.2 (0.089±0.008)		
P2*2	1.5±0.2 (0.059±0.008)			—			1.5±0.2 (0.059±0.008)		

※1: 半田付け前の参考値です。 ※1: Pre-soldering reference values. Unit: mm(inch)
 ※2: 端子ピッチは端子根本に適用 ※2: Terminal pitch is measured at the terminal origins rather than ends.

トランス仕様 SPECIFICATIONS

形式 Type	使用周波数帯 [Hz] Operating frequency range	※最大出力電力 [Watts] Max output dissipation	絶縁抵抗 [MΩ]min Insulation Resistance	耐電圧 [VAC] Withstand Voltage	備考 Remarks
V 06DDA	10k~1M	0.6	100 (DC 100V)	500 (1 minute)	非シールドタイプ Non-shielded type
V 06DDB					
V 06DDC					
V 08DDA					
V 08DDB					
V 08DDC					
VP 06DDA		0.6			磁気シールドタイプ Shielded type
VP 06DDB					
VP 06DDC					

※最大出力電力は、使用条件により異なりますので、目安として下さい。
 Since maximum electrical power output will vary depending on operating conditions, this figure should be used as reference only.

セクションガイド
Selection Guide

アイテム一覧
Part Numbers

特性図
Electrical Characteristics

梱包
Packaging

信頼性
Reliability Data

使用上の注意
Precautions



etc

梱包 PACKAGING

①標準数量 Standard quantity

SMDインダクタ SMD INDUCTOR

形式 Type	高さ記号 Height code	標準数量 Standard quantity(pcs.) テーピング Taped
N05D	B	1500
NP05D	B	1500
N06D	B	1500
NP06D	B	1500
N08DP	A	1000
N08DP	B	1500

SMDトランス SMD TRANSFORMER

形式 Type	高さ記号 Height code	標準数量 Standard quantity(pcs.) テーピング Taped
V06DD	A	1000
	B	1000
	C	1500
V08DD	A	1000
	B	1000
	C	1500
VP06DD	A	900
	B	900
	C	1500

②テーピング材質 Tape Material

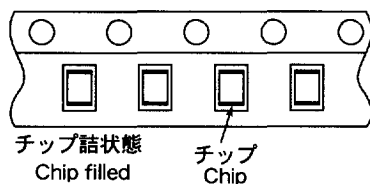
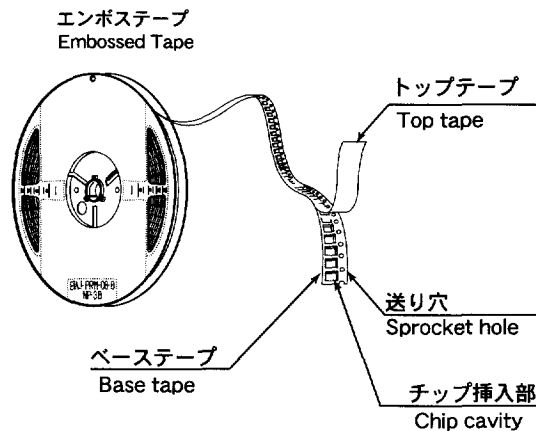

③テーピング寸法 Taping dimensions

(1)エンボステープ (16mm幅) Embossed tape(0.63 inches wide)

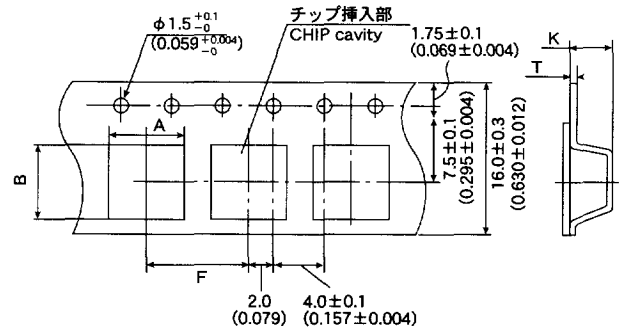

SMDインダクタ SMD INDUCTOR

形式 Type	高さ記号 Height code	チップ挿入部 Chip cavity			挿入ピッチ Insertion pitch		テープ厚み Tape thickness	
		A	B	F	K	T		
N 05D	B	6.1 (0.240)	6.3 (0.248)	12 (0.472)	3.4 (0.134)	0.4 (0.016)		
NP05D	B	6.1 (0.240)	6.3 (0.248)	12 (0.472)	3.4 (0.134)	0.4 (0.016)		
N06D	B	7.5 (0.295)	7.7 (0.303)	12 (0.472)	3.5 (0.138)	0.4 (0.016)		
NP06D	B	7.5 (0.295)	7.7 (0.303)	12 (0.472)	3.5 (0.138)	0.4 (0.016)		

Unit : mm(inch)

SMDトランス SMD TRANSFORMER

形式 Type	高さ記号 Height code	チップ挿入部 Chip cavity			挿入ピッチ Insertion pitch		テープ厚み Tape thickness	
		A	B	F	K	T		
V06DD	A	6.5 (0.256)	8.8 (0.346)	8 (0.315)	6.2 (0.244)	0.4 (0.016)		
	B	6.5 (0.256)	8.8 (0.346)	8 (0.315)	6.2 (0.244)	0.4 (0.016)		
	C	6.5 (0.256)	8.8 (0.346)	8 (0.315)	4.2 (0.165)	0.4 (0.016)		
VP06DD	A	8.8 (0.346)	9.0 (0.354)	12 (0.472)	6.4 (0.252)	0.4 (0.016)		
	B	8.8 (0.346)	9.0 (0.354)	12 (0.472)	6.4 (0.252)	0.4 (0.016)		
	C	8.8 (0.346)	9.0 (0.354)	12 (0.472)	3.9 (0.154)	0.4 (0.016)		

Unit : mm(inch)

公差のない数値は参考値です。

The values without tolerance are for reference only.

梱包 PACKAGING

Tape Material

(2)エンボステープ (24mm幅) Embossed Tape(0.94 inches wide)

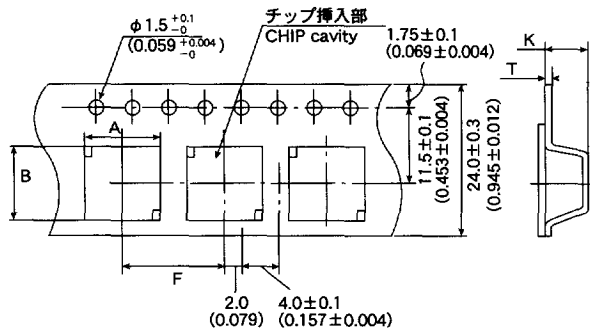

SMDインダクタ SMD INDUCTOR

形式 Type	高さ記号 Height code	チップ挿入部 Chip cavity			挿入ピッチ Insertion pitch		テープ厚み Tape thickness	
		A	B	F	K	T		
N08DP	A	9.4 (0.370)	11.0 (0.433)	12 (0.472)	6.0 (0.236)	0.4 (0.016)		
	B	9.4 (0.370)	11.0 (0.433)	12 (0.472)	5.0 (0.197)	0.4 (0.016)		

Unit: mm(inch)

SMDトランス SMD TRANSFORMER

形式 Type	高さ記号 Height code	チップ挿入部 Chip cavity		挿入ピッチ Insertion pitch	テープ厚み Tape thickness	
		A	B		K	T
V08DD	A	9.7 (0.382)	12.4 (0.488)	12 (0.472)	7.0 (0.276)	0.4 (0.016)
	B	9.7 (0.382)	12.4 (0.488)	12 (0.472)	6.0 (0.236)	0.4 (0.016)
	C	9.7 (0.382)	12.4 (0.488)	12 (0.472)	5.0 (0.197)	0.4 (0.016)

Unit: mm(inch)

公差のない数値は参考値です。

The values without tolerance are for reference only.

④リーダ部・空部 Leader and Blank portion

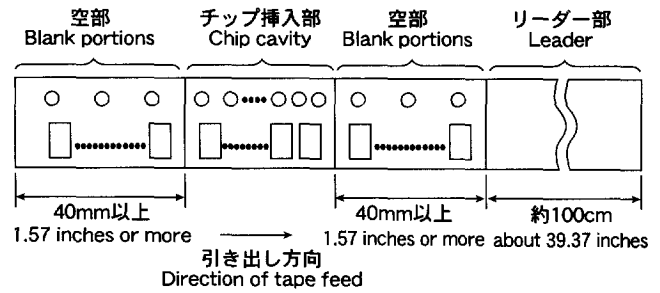

⑤リール寸法 Reel size

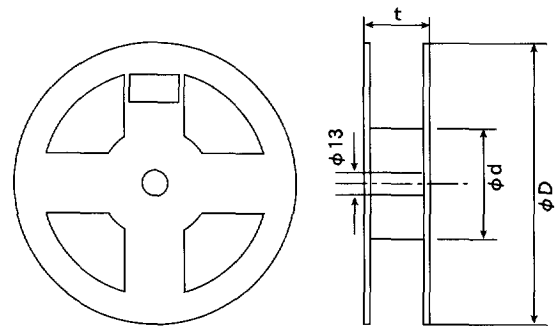

形式 Type	リール寸法 Reel size(mm) (参考値 Reference values)		
	ϕD	ϕd	t
N05D	330(12.99)	80(3.15)	21.5(0.846)
NP05D	330(12.99)	80(3.15)	21.5(0.846)
N06D	330(12.99)	80(3.15)	21.5(0.846)
NP06D	330(12.99)	80(3.15)	21.5(0.846)
V06DD	330(12.99)	100(3.94)	21.5(0.846)
VP06DD	330(12.99)	100(3.94)	21.5(0.846)
N08DP	380(14.96)	80(3.15)	29.5(1.16)
V08DD	380(14.96)	80(3.15)	29.5(1.16)

⑥トップテープ強度 Top Tape Strength

トップテープのはがし力は、下図矢印方向にて0.1~0.7Nとなります。

The top tape requires a peel-off force of 0.1 to 0.7N in the direction of the arrow as illustrated below.

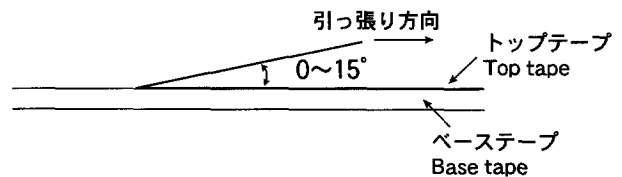

SMDインダクタ / SMDトランス

項目	規格値		試験方法・摘要										
	SMDトランス	SMDインダクタ											
1.使用温度範囲	-25℃~+85℃	08タイプ -25℃~+85℃ 05, 06タイプ -25℃~+105℃	(自己発熱による温度上昇を含む)										
2.保存温度範囲	-40℃~+85℃												
3.絶縁抵抗	巻線間	100MΩ以上	印加電圧：100VDC 印加時間：60秒										
	巻線-コア間	100MΩ以上	印加電圧：100VDC 印加時間：60秒										
4.直流抵抗	規定の許容差内にあること。		測定器：直流抵抗計										
5.インダクタンス	規定の許容差内にあること。		測定器：4284A(HP)又は同等品 測定周波数：1kHz 測定電圧：1Vosc直列測定										
6.自己共振周波数	—	規定の範囲内にあること。	測定器：インピーダンスアナライザ (HP4191A、4192A) 同等品										
7.温度特性 (インダクタンス)	—	05, 06タイプ：±10%以内 08タイプ：±5%以内	段階1~5における最大インダクタンス偏差の変化率 <table border="1"> <tr><td>段階1の温度</td><td>20℃</td></tr> <tr><td>段階2の温度</td><td>最低使用温度</td></tr> <tr><td>段階3の温度</td><td>20℃(基準温度)</td></tr> <tr><td>段階4の温度</td><td>最高使用温度</td></tr> <tr><td>段階5の温度</td><td>20℃</td></tr> </table>	段階1の温度	20℃	段階2の温度	最低使用温度	段階3の温度	20℃(基準温度)	段階4の温度	最高使用温度	段階5の温度	20℃
段階1の温度	20℃												
段階2の温度	最低使用温度												
段階3の温度	20℃(基準温度)												
段階4の温度	最高使用温度												
段階5の温度	20℃												
8.定格電流	—	規定の範囲内にあること。	直流重量によるインダクタンス低下10%以内、又は温度上昇40℃以下のいずれも満足する最大直流電流値										
9.耐電圧	巻線間	異常のないこと。	方法1又は方法2で行う <table border="1"> <tr><td></td><td>方法1</td><td>方法2</td></tr> <tr><td>印加電圧</td><td>500VAC</td><td>600VAC</td></tr> <tr><td>印加時間</td><td>60秒</td><td>1秒</td></tr> </table>		方法1	方法2	印加電圧	500VAC	600VAC	印加時間	60秒	1秒	
		方法1	方法2										
印加電圧	500VAC	600VAC											
印加時間	60秒	1秒											
巻線-コア間	異常のないこと。	SMDトランス：方法1又は方法2で行う <table border="1"> <tr><td></td><td>方法1</td><td>方法2</td></tr> <tr><td>印加電圧</td><td>500VAC</td><td>600VAC</td></tr> <tr><td>印加時間</td><td>60秒</td><td>1秒</td></tr> </table> SMDインダクタ 印加電圧：500VAC 印加時間：60秒		方法1	方法2	印加電圧	500VAC	600VAC	印加時間	60秒	1秒		
	方法1	方法2											
印加電圧	500VAC	600VAC											
印加時間	60秒	1秒											
10.端子強度	異常のないこと。	—	端子の引張り、押込み各方向に5Nの静荷重を30秒間加える。										
11.端子電極固着力	—	異常のないこと。	プリント基板に取付けた試料の上面側に垂直に引き剥がし治具を当て、規定の静荷重を5秒間加える。 規定静荷重 <table border="1"> <tr><td>タイプ</td><td>静荷重</td></tr> <tr><td>N08DP</td><td>10N</td></tr> <tr><td>N06D</td><td rowspan="2">5N</td></tr> <tr><td>NP06D</td></tr> </table>	タイプ	静荷重	N08DP	10N	N06D	5N	NP06D			
タイプ	静荷重												
N08DP	10N												
N06D	5N												
NP06D													
12.耐振性	インダクタンス変化率：±5%以内		JIS C 0040によります。 振動の方向：X、Y、Z方向に各2時間、計8時間 振動周波数：10~55~10Hz(1分間) 全振幅：1.5mm(但し、加速度196m/s ² を超えないこと。) 製品保持：プリント基板にはんだ付け 後処理：試験後、標準状態に2時間以上放置後、24時間以内に測定する。										
13.はんだ付け性	はんだが一様に付着すること。	実装端子側面の95%以上が新しいはんだで覆われていること。	SMDトランス はんだ温度：230±5℃ 浸漬時間：2±0.5秒 浸漬深さ：端子根元から0.5~1.0mmのところまで SMDインダクタ はんだ温度：230±5℃ 浸漬時間：2±0.5秒 浸漬深さ：実装端子側面を浸漬する。										

SURFACE MOUNT HIGH CURRENT INDUCTOR / SURFACE MOUNT TRANSFORMER

Item	Specified Value			Test Methods and Remarks									
	SMD transformer	SMD inductor											
		08 type	05, 06 type										
1. Operating Temperature Range	-25 to +85°C	-25 to +85°C	-25 to +105°C	Including self-generated heat									
2. Storage Temperature Range	-40 to +85°C												
3. Insulation Resistance	Between wires	100MΩ min.	—	Applied voltage : 100VDC Duration : 60 sec									
	Between wire and core	100MΩ min.	—	Applied voltage : 100VDC Duration : 60 sec.									
4. DC Resistance	Within the specified tolerance			Measuring equipment : DC ohmmeter									
5. Inductance	Within the specified tolerance			Measuring equipment : 4284A(HP) or its equivalent Measuring frequency : 1kHz Measuring voltage : 1V osc. measurement in series connection									
6. Self Resonance Frequency	—	Within the specified tolerance		Measuring equipment : Impedance analyzer (HP 4191A, 4192A) or its equivalent									
7. Temperature Characteristic (Inductance)	—	05, 06 type : Within ±10% 08 type : Within ±5%		Change of maximum inductance deviation in step 1 to 5 Temperature at step 1 : 20°C Temperature at step 2 : Minimum operating temperature Temperature at step 3 : 20°C (Standard temperature) Temperature at step 4 : Maximum operating temperature Temperature at step 5 : 20°C									
8. Rated Current	—	Within the specified range		The maximum DC value having inductance decrease within 10% and temperature increase within 40°C by the application of DC bias.									
9. Withstanding Voltage	Between wires	No abnormality	—	According to method 1 or 2 <table border="1"> <tr> <td></td> <td>method 1</td> <td>method 2</td> </tr> <tr> <td>Applied voltage</td> <td>500VAC</td> <td>600VAC</td> </tr> <tr> <td>Duration</td> <td>60 sec.</td> <td>1sec.</td> </tr> </table>		method 1	method 2	Applied voltage	500VAC	600VAC	Duration	60 sec.	1sec.
		method 1	method 2										
Applied voltage	500VAC	600VAC											
Duration	60 sec.	1sec.											
Between wire and core	No abnormality	—		SMD transformer According to method 1 or 2 <table border="1"> <tr> <td></td> <td>method 1</td> <td>method 2</td> </tr> <tr> <td>Applied voltage</td> <td>500VAC</td> <td>600VAC</td> </tr> <tr> <td>Duration</td> <td>60 sec.</td> <td>1sec.</td> </tr> </table> SMD inductor Applied voltage : 500VAC Duration : 60 sec.		method 1	method 2	Applied voltage	500VAC	600VAC	Duration	60 sec.	1sec.
	method 1	method 2											
Applied voltage	500VAC	600VAC											
Duration	60 sec.	1sec.											
10. Terminal Strength	No abnormality	—		Apply 5N of static load to tensile and thrust directions of terminals for 30 sec.									
11. Adhesion of Terminal Electrode	—	No abnormality		Set testing jigs perpendicularly to top surface of specimen mounted on printed board, and apply specified static load for 5 sec. Specified static load <table border="1"> <tr> <td>Type</td> <td>static load</td> </tr> <tr> <td>N08DP</td> <td>10N</td> </tr> <tr> <td>N06D</td> <td rowspan="2">5N</td> </tr> <tr> <td>NP06D</td> </tr> </table>	Type	static load	N08DP	10N	N06D	5N	NP06D		
Type	static load												
N08DP	10N												
N06D	5N												
NP06D													
12. Resistance to Vibration	Inductance change : Within ±5%			According to JIS C 0040. Directions : 2 hrs each in X, Y, and Z directions Total : 6 hrs Frequency range : 10 to 55 to 10 Hz (1 min.) Amplitude : 1.5mm (shall not exceed acceleration 196m/s ²) Mounting method : Soldering onto printed board Recovery : At least 2 hrs of recovery under the standard condition after the test, followed by the measurement within 24 hrs.									
13. Solderability	Solder shall be uniformly adhered.	95% or more of mounting terminal side shall be covered with fresh solder.		SMD transformer Solder temperature : 230±5°C Duration : 2±0.5 sec. Immersion depth : Up to 0.5 to 1.0mm from terminal root SMD inductor Solder temperature : 230±5°C Duration : 2±0.5 sec. Immersion depth : All sides of mounting terminal shall be immersed.									

5 FERRITE PRODUCTS

SMDインダクタ / SMDトランス

項目	規格値		試験方法・摘要																														
	SMDトランス	SMDインダクタ																															
14. はんだ耐熱性	異常のないこと。		<p>SMDトランス(はんだ浸漬法)</p> <p>はんだ温度：260±5℃ 浸漬時間：5±1秒 浸漬深さ：端子根本から0.5~1.0mmのところまで</p> <p>SMDインダクタ(リフローはんだ法)</p> <p>推奨リフロー条件値</p> <table border="1"> <tr> <td>温度範囲</td> <td>150~180℃</td> <td>180℃以上</td> <td>200℃以上</td> <td>ピーク温度230℃max</td> </tr> <tr> <td>保持時間</td> <td>110秒max</td> <td>40秒max</td> <td>30秒max</td> <td></td> </tr> </table> <p>後処理：試験後、標準状態に2時間以上放置後、24時間以内に測定する。</p>	温度範囲	150~180℃	180℃以上	200℃以上	ピーク温度230℃max	保持時間	110秒max	40秒max	30秒max																					
温度範囲	150~180℃	180℃以上	200℃以上	ピーク温度230℃max																													
保持時間	110秒max	40秒max	30秒max																														
15. 温度サイクル	インダクタンス変化率：±10%以内		<p>JIS C 0025による。</p> <p>SMDトランス、SMDインダクタ (08タイプ)</p> <p>1 サイクルの条件</p> <table border="1"> <thead> <tr> <th>段階</th> <th>温度(℃)</th> <th>時間(min)</th> </tr> </thead> <tbody> <tr> <td>1</td> <td>-25⁺⁵/₋₅</td> <td>30±3</td> </tr> <tr> <td>2</td> <td>常温</td> <td>3以下</td> </tr> <tr> <td>3</td> <td>+85⁺⁵/₋₅</td> <td>30±3</td> </tr> <tr> <td>4</td> <td>常温</td> <td>3以下</td> </tr> </tbody> </table> <p>SMDインダクタ (05、06タイプ)</p> <p>1 サイクルの条件</p> <table border="1"> <thead> <tr> <th>段階</th> <th>温度(℃)</th> <th>時間(min)</th> </tr> </thead> <tbody> <tr> <td>1</td> <td>-25⁺⁵/₋₅</td> <td>30±3</td> </tr> <tr> <td>2</td> <td>常温</td> <td>3以下</td> </tr> <tr> <td>3</td> <td>+105⁺²/₋₂</td> <td>30±3</td> </tr> <tr> <td>4</td> <td>常温</td> <td>3以下</td> </tr> </tbody> </table> <p>試験回数：10サイクル</p> <p>後処理：槽から取り出し、標準状態に2時間以上放置後、24時間以内に測定する。</p>	段階	温度(℃)	時間(min)	1	-25 ⁺⁵ / ₋₅	30±3	2	常温	3以下	3	+85 ⁺⁵ / ₋₅	30±3	4	常温	3以下	段階	温度(℃)	時間(min)	1	-25 ⁺⁵ / ₋₅	30±3	2	常温	3以下	3	+105 ⁺² / ₋₂	30±3	4	常温	3以下
段階	温度(℃)	時間(min)																															
1	-25 ⁺⁵ / ₋₅	30±3																															
2	常温	3以下																															
3	+85 ⁺⁵ / ₋₅	30±3																															
4	常温	3以下																															
段階	温度(℃)	時間(min)																															
1	-25 ⁺⁵ / ₋₅	30±3																															
2	常温	3以下																															
3	+105 ⁺² / ₋₂	30±3																															
4	常温	3以下																															
16. 耐湿性(定常状態)	インダクタンス変化率：±10%以内		<p>温度：40±2℃ 湿度：90~95% 試験時間：96±2時間 後処理：槽から取り出し、標準状態に2時間以上放置後、24時間以内に測定する。</p>																														
17. 耐湿負荷	インダクタンス変化率：±10%以内		<p>温度：40±2℃ 湿度：90~95% 印加電流：定格電流 試験時間：240±2時間 後処理：槽から取り出し、標準状態に2時間以上放置後、24時間以内に測定する。</p>																														
18. 高温放置	インダクタンス変化率：±10%以内		<p>温度： SMDトランス : 85±2℃ SMDインダクタ : 105±3℃</p> <p>試験時間： SMDトランス : 96±2時間 SMDインダクタ : 240±2時間</p> <p>後処理：槽から取り出し、標準状態に2時間以上放置後、24時間以内に測定する。</p>																														
19. 低温放置	インダクタンス変化率：±10%以内		<p>温度：-40±3℃</p> <p>試験時間： SMDトランス : 96±2時間 SMDインダクタ : 240±2時間</p> <p>後処理：槽から取り出し、標準状態に2時間以上放置後、24時間以内に測定する。</p>																														

標準状態：標準状態とは、下記の状態をいいます。

温度：5~35℃、相対湿度：45~85%、気圧：86~106kPa

但し、判定に疑義を生じた場合は、温度：20±2℃、相対湿度：60~70%、気圧：86~106kPaで行います。

特に指定のない限り全ての試験は標準状態で行います。

SURFACE MOUNT INDUCTOR / SURFACE MOUNT TRANSFORMER

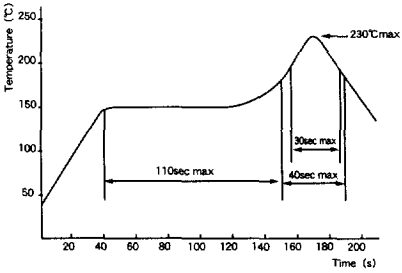
Item	Specified Value		Test Methods and Remarks																														
	SMD transformer	SMD inductor																															
14. Resistance to Soldering Heat	No abnormality		<p>SMD transformer(Dip soldering method) Solder temperature : 260±5°C Duration : 5±1 sec. Immersion depth : Up to 0.5 to 1.0mm from terminal root</p> <p>SMD inductor(Reflow soldering method) Recommended reflow conditions</p>  <p>Recommended reflow conditions</p> <table border="1"> <tr> <td>Temperature</td> <td>150-180°C</td> <td>over 180°C</td> <td>over 200°C</td> <td>Peak temperature 230°C max</td> </tr> <tr> <td>Duration</td> <td>110 sec. max.</td> <td>40 sec. max.</td> <td>30 sec. max.</td> <td></td> </tr> </table> <p>Recovery : At least 2 hrs of recovery under the standard condition after the test, followed by the measurement within 24 hrs.</p>	Temperature	150-180°C	over 180°C	over 200°C	Peak temperature 230°C max	Duration	110 sec. max.	40 sec. max.	30 sec. max.																					
Temperature	150-180°C	over 180°C	over 200°C	Peak temperature 230°C max																													
Duration	110 sec. max.	40 sec. max.	30 sec. max.																														
15. Thermal Shock	Inductance change : Within ±10%		<p>According to JIS C 0025.</p> <p>SMD transformer, SMD inductor (08 type) Conditions for 1 cycle</p> <table border="1"> <tr> <th>Step</th> <th>Temperature(°C)</th> <th>Duration (min.)</th> </tr> <tr> <td>1</td> <td>-25⁺⁰/₋₃</td> <td>30±3</td> </tr> <tr> <td>2</td> <td>Room temperature</td> <td>Within 3</td> </tr> <tr> <td>3</td> <td>+85⁺⁰/₋₂</td> <td>30±3</td> </tr> <tr> <td>4</td> <td>Room temperature</td> <td>Within 3</td> </tr> </table> <p>SMD inductor (05, 06 type) Conditions for 1 cycle</p> <table border="1"> <tr> <th>Step</th> <th>Temperature(°C)</th> <th>Duration (min.)</th> </tr> <tr> <td>1</td> <td>-25⁺⁰/₋₃</td> <td>30±3</td> </tr> <tr> <td>2</td> <td>Room temperature</td> <td>Within 3</td> </tr> <tr> <td>3</td> <td>+105⁺⁰/₋₂</td> <td>30±3</td> </tr> <tr> <td>4</td> <td>Room temperature</td> <td>Within 3</td> </tr> </table> <p>Number of cycles : 10 cycles Recovery : At least 2 hrs of recovery under the standard condition after the removal from test chamber, followed by the measurement within 24 hrs.</p>	Step	Temperature(°C)	Duration (min.)	1	-25 ⁺⁰ / ₋₃	30±3	2	Room temperature	Within 3	3	+85 ⁺⁰ / ₋₂	30±3	4	Room temperature	Within 3	Step	Temperature(°C)	Duration (min.)	1	-25 ⁺⁰ / ₋₃	30±3	2	Room temperature	Within 3	3	+105 ⁺⁰ / ₋₂	30±3	4	Room temperature	Within 3
Step	Temperature(°C)	Duration (min.)																															
1	-25 ⁺⁰ / ₋₃	30±3																															
2	Room temperature	Within 3																															
3	+85 ⁺⁰ / ₋₂	30±3																															
4	Room temperature	Within 3																															
Step	Temperature(°C)	Duration (min.)																															
1	-25 ⁺⁰ / ₋₃	30±3																															
2	Room temperature	Within 3																															
3	+105 ⁺⁰ / ₋₂	30±3																															
4	Room temperature	Within 3																															
16. Damp Heat (steady state)	Inductance change: Within ±10%		<p>Temperature : 40±2°C Humidity : 90 to 95% Duration : 96±2 hrs Recovery : At least 2 hrs of recovery under the standard condition after the removal from test chamber, followed by the measurement within 24 hrs.</p>																														
17. Loading under Damp Heat		Inductance change : Within ±10%	<p>Temperature : 40±2°C Humidity : 90 to 95% Applied current : Rated current Duration : 240±2 hrs Recovery : At least 2 hrs of recovery under the standard condition after the removal from test chamber, followed by the measurement within 24 hrs.</p>																														
18. High Temperature Life Test	Inductance change : Within ±10%		<p>Temperature : 85±2°C(SMD transformer) 105±3°C(SMD inductor) Duration : 96±2 hrs(SMD transformer) 240±2 hrs(SMD inductor) Recovery : At least 2 hrs of recovery under the standard condition after the removal from test chamber, followed by the measurement within 24 hrs.</p>																														
19. Low Temperature Life Test	Inductance change : Within ±10%		<p>Temperature : -40±3°C Duration : 96±2 hrs(SMD transformer) 240±2 hrs(SMD inductor) Recovery : At least 2 hrs of recovery under the standard condition after the removal from test chamber, followed by the measurement within 24 hrs.</p>																														

Note on standard condition: "standard condition" referred to herein is defined as follows:
5 to 35°C of temperature, 45 to 85% relative humidity and 86 to 106kPa of air pressure.

When there are questions concerning measurement results:

In order to provide correlation data, the test shall be conducted under condition of 20±2°C of temperature, 45 to 85% relative humidity and 86 to 106kPa of air pressure.

Unless otherwise specified, all the tests are conducted under the "standard condition."