

## 3.3V, Wide Bandwidth, 8-Channel, 2:1, Mux/Demux USB 2.0 Switch with Single Enable

### Product Features

- RON is 4Ω typical
- Low bit-to-bit skew: 200ps
- Low crosstalk: -27dB @ 250MHz
- Low Current Consumption: 20μA
- Near Zero propagation delay: 250ps
- Switching speed: 9ns
- Channel On capacitance: 6pF (typical)
- VCC Operating Range: +3.0V to +3.6V
- ESD>2000V . . . Human Body Model
- >500 MHz bandwidth (or data frequency)
- Package (Pb-free available):  
48-pin 240 mil wide plastic TSSOP (A)

### Product Description

Pericom Semiconductor's PI3USB series of logic circuits are produced using the Company's advanced sub-micron CMOS technology, achieving industry leading performance.

The PI3USB40 is a 16- to 8-channel multiplexer/demultiplexer USB Switch with Hi-Z outputs. Industry leading advantages include a propagation delay of less than 250ps, resulting from its low channel resistance and I/O capacitance. The device multiplexes differential outputs from a USB transceiver device to one of two corresponding outputs. The switch is bidirectional and offers little or no attenuation of the high-speed signals at the outputs. It is designed for low bit-to-bit skew, high channel-to-channel noise isolation and is compatible with various standards, such as High Speed USB 2.0 (480 Mb/s).

### Applications

- Routes physical layer signals for USB 2.0

### Logic Block Diagram

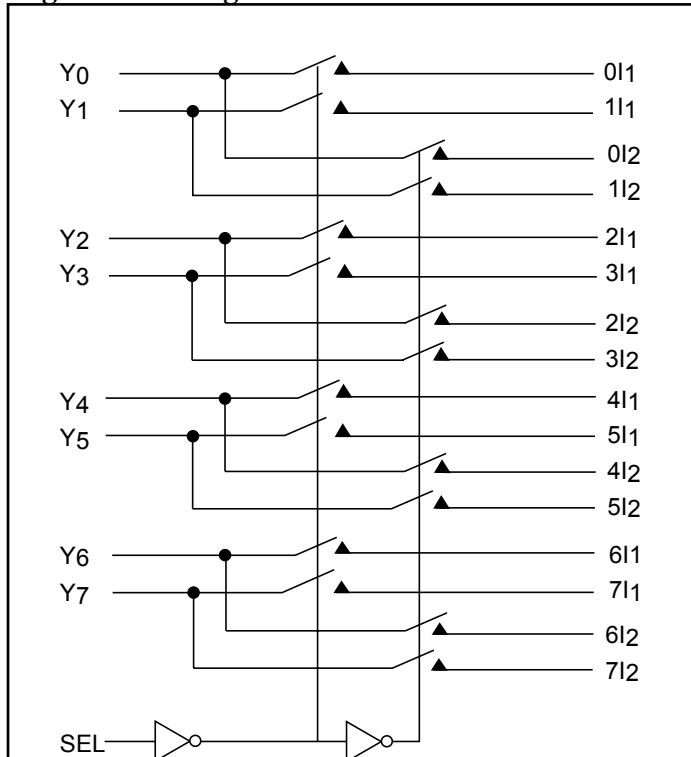

### Pin Description

|     |    |    |     |
|-----|----|----|-----|
| VDD | 1  | 48 | 0 1 |
| Y0  | 2  | 47 | 1 1 |
| GND | 3  | 46 | GND |
| Y1  | 4  | 45 | 0 2 |
| GND | 5  | 44 | 1 2 |
| VDD | 6  | 43 | GND |
| GND | 7  | 42 | 2 1 |
| Y2  | 8  | 41 | 3 1 |
| GND | 9  | 40 | GND |
| Y3  | 10 | 39 | 2 2 |
| GND | 11 | 38 | 3 2 |
| VDD | 12 | 37 | GND |
| GND | 13 | 36 | VDD |
| NC  | 14 | 35 | 4 1 |
| Y4  | 15 | 34 | 5 1 |
| GND | 16 | 33 | GND |
| Y5  | 17 | 32 | 4 2 |
| GND | 18 | 31 | 5 2 |
| VDD | 19 | 30 | GND |
| GND | 20 | 29 | 6 1 |
| Y6  | 21 | 28 | 7 1 |
| GND | 22 | 27 | GND |
| Y7  | 23 | 26 | 6 2 |
| SEL | 24 | 25 | 7 2 |

### Maximum Ratings

(Above which useful life may be impaired. For user guidelines, not tested.)

|   |                 |
|---|-----------------|
| Storage Temperature.....                | -65°C to +150°C |
| Supply Voltage to Ground Potential..... | -0.5V to +4.0V  |
| DC Input Voltage.....                   | -0.5V to +5.5V  |
| DC Output Current.....                  | 120mA           |
| Power Dissipation.....                  | 0.5W            |

### Truth Table

| Function         | SEL |
|------------------|-----|
| $Y_N$ to $N I_1$ | L   |
| $Y_N$ to $N I_2$ | H   |

#### Note:

Stresses greater than those listed under MAXIMUM RATINGS may cause permanent damage to the device. This is a stress rating only and functional operation of the device at these or any other conditions above those indicated in the operational sections of this specification is not implied. Exposure to absolute maximum rating conditions for extended periods may affect reliability.

### DC Electrical Characteristics for USB 2.0 Switching over Operating Range

( $T_A = -40^\circ\text{C}$  to  $+85^\circ\text{C}$ ,  $V_{CC} = 3.3\text{V} \pm 10\%$ )

| Parameter       | Description  | Test Conditions  | Min. | Typ.(2) | Max.    | Units         |
|-----------------|--|--|------|---------|---------|---------------|
| $V_{IH}$        | Input HIGH Voltage   | Guaranteed HIGH level  | 2    | -       | -       | V             |
| $V_{IL}$        | Input LOW Voltage  | Guaranteed LOW level   | -0.5 | -       | 0.8     |               |
| $V_{IK}$        | Clamp Diode Voltage  | $V_{CC} = \text{Max.}, I_{IN} = -18\text{mA}$  | -    | -0.7    | -1.2    |               |
| $I_{IH}$        | Input HIGH Current   | $V_{CC} = \text{Max.}, V_{IN} = V_{CC}$  | -    | -       | $\pm 5$ | $\mu\text{A}$ |
| $I_{IL}$        | Input LOW Current  | $V_{CC} = \text{Max.}, V_{IN} = \text{GND}$  | -    | -       | $\pm 5$ |               |
| $I_{OFF}$       | Power Down Leakage Current   | $V_{CC} = 0\text{V}, V_A = 0\text{V}, V_B \leq 3.6$                                    | -    | -       | -       |               |
| $R_{ON}$        | Switch On-Resistance <sup>(3)</sup>                                    | $V_{CC} = \text{Min.}, 1.5\text{V} \leq V_{IN} \leq V_{CC}$<br>$I_{IN} = -40\text{mA}$ | -    | 4       | 8       | $\Omega$      |
| $R_{FLAT(ON)}$  | On-Resistance Flatness <sup>(4)</sup>                                  | $V_{CC} = \text{Min.}, V_{IN} @ 1.5\text{V}$ and $V_{CC}$<br>$I_{IN} = -40\text{mA}$   | -    | 1       | -       |               |
| $\Delta R_{ON}$ | On-Resistance match from center ports to any other port <sup>(4)</sup> | $V_{CC} = \text{Min.}, 1.5\text{V} \leq V_{IN} \leq V_{CC}$<br>$I_{IN} = -40\text{mA}$ | -    | 0.9     | 2       |               |

**Capacitance** ( $T_A = 25^\circ\text{C}$ ,  $f = 1\text{MHz}$ )

| Parameters <sup>(5)</sup> | Description                    | Test Conditions      | Typ. | Max. | Units |
|---------------------------|--------------------------------|----------------------|------|------|-------|
| $C_{IN}$                  | Input Capacitance              | $V_{IN} = 0\text{V}$ | 2.0  | 3.0  | pF    |
| $C_{OFF}$                 | Port I Capacitance, Switch OFF |                      | 4.0  | 6.0  |       |
| $C_{ON}$                  | Switch Capacitance, Switch ON  |                      | 6.0  | 10.0 |       |

**Notes:**

1. For max. or min. conditions, use appropriate value specified under Electrical Characteristics for the applicable device type.
2. Typical values are at  $V_{CC} = 3.3\text{V}$ ,  $T_A = 25^\circ\text{C}$  ambient and maximum loading.
3. Measured by the voltage drop between A and B pins at indicated current through the switch. ON-resistance is determined by the lower of the voltages on the two (A & B) pins.
4. This parameter is determined by device characterization but is not production tested.

**Power Supply Characteristics**

| Parameters | Description                    | Test Conditions <sup>(1)</sup>                            | Min. | Typ. <sup>(2)</sup> | Max. | Units         |
|------------|--------------------------------|---|------|---------------------|------|---------------|
| $I_{CC}$   | Quiescent Power Supply Current | $V_{CC} = \text{Max.}$ , $V_{IN} = \text{GND or } V_{CC}$ | -    | -                   | 800  | $\mu\text{A}$ |

**Notes:**

1. For max. or min. conditions, use appropriate value specified under Electrical Characteristics for the applicable device type.
2. Typical values are at  $V_{CC} = 3.3\text{V}$ ,  $T_A = 25^\circ\text{C}$  ambient and maximum loading.
3. Per TTL driven input (control inputs only); A and B pins do not contribute to  $I_{CC}$ .

**Dynamic Electrical Characteristics Over the Operating Range** ( $T_A = -40^\circ$  to  $+85^\circ\text{C}$ ,  $V_{CC} = 3.3\text{V} \pm 10\%$ ,  $\text{GND} = 0\text{V}$ )

| Parameter  | Description    | Test Conditions                         | Min. | Typ. <sup>(2)</sup> | Max. | Units |
|------------|----------------|---|------|---------------------|------|-------|
| $X_{TALK}$ | Crosstalk      | $R_L = 100\Omega$ , $f = 250\text{MHz}$ | -    | -27                 | -    | dB    |
| $O_{IRR}$  | OFF Isolation  |   | -    | -32                 | -    |       |
| BW         | Bandwidth -3dB | $R_L = 100\Omega$                       | -    | 500                 | -    | MHz   |

**Switching Characteristics**

| Parameter             | Description   | Test Conditions | Min. | Typ. <sup>(2)</sup> | Max. | Units |
|-----------------------|---|-----------------|------|---------------------|------|-------|
| $t_{PD}$              | Propagation Delay <sup>(2,3)</sup>  |                 | -    | 0.25                |      | ns    |
| $t_{PZH}$ , $t_{PZL}$ | Line Enable Time - SEL to $Y_N$ , $I_N$   |                 | 0.5  | -                   | 15   |       |
| $t_{PHZ}$ , $t_{PLZ}$ | Line Disable Time - SEL to $Y_N$ , $I_N$  |                 | 0.5  | -                   | 9    |       |
| $t_{SK(o)}$           | Output Skew between center port (Y4 to Y5) to any other port <sup>(2)</sup>                   |                 | -    | 0.1                 | 0.2  |       |
| $t_{SK(p)}$           | Skew between opposite transitions of the same output ( $t_{PHL}$ - $t_{PLH}$ ) <sup>(2)</sup> |                 | -    | 0.1                 | 0.2  |       |

**Notes:**

1. For max. or min. conditions, use appropriate value specified under Electrical Characteristics for the applicable device type.
2. Guaranteed by design.
3. The bus switch contributes no propagational delay other than the RC delay of the ON-resistance of the switch and the load capacitance. The time constant for the switch alone is of the order of 0.25ns for 10pF load. Since this time constant is much smaller than the rise/fall times of typical driving signals, it adds very little propagational delay to the system. Propagational delay of the bus switch when used in a system is determined by the driving circuit on the driving side of the switch and its interactions with the load on the driven side.

### Test Circuit for Electrical Characteristics<sup>(1)</sup>

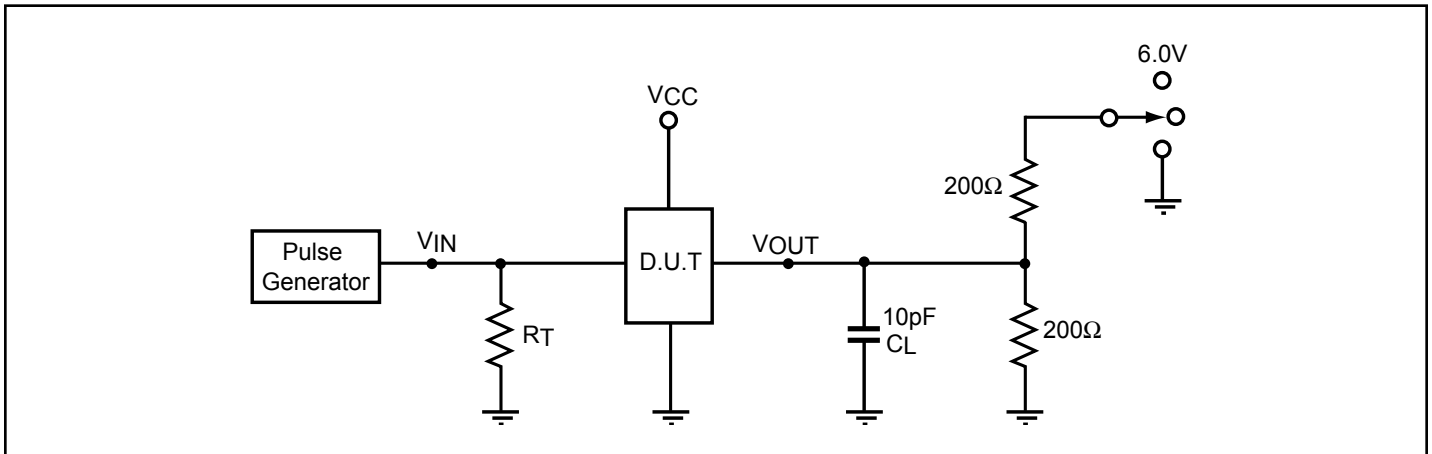

**Notes:**

1.  $C_L$  = Load capacitance: includes jig and probe capacitance.
2.  $R_T$  = Termination resistance: should be equal to  $Z_{OUT}$  of the Pulse Generator
3. Waveform 1 is for an output with internal conditions such that the output is low except when disabled by the output control.  
 Waveform 2 is for an output with internal conditions such that the output is high except when disabled by the output control.
4. All input impulses are supplied by generators having the following characteristics:  $PRR \leq \text{MHz}$ ,  $Z_O = 50\Omega$ ,  $t_R \leq 2.5\text{ns}$ ,  $t_F \leq 2.5\text{ns}$ .
5. The outputs are measured one at a time with one transition per measurement.

### Switch Positions

| Test                                     | Switch |
|--|--------|
| $t_{PLZ}$ , $t_{PZL}$ (output on B-side) | 6.0V   |
| $t_{PHZ}$ , $t_{PZH}$ (output on B-side) | GND    |
| Prop Delay                               | Open   |

### Test Circuit for Dynamic Electrical Characteristics

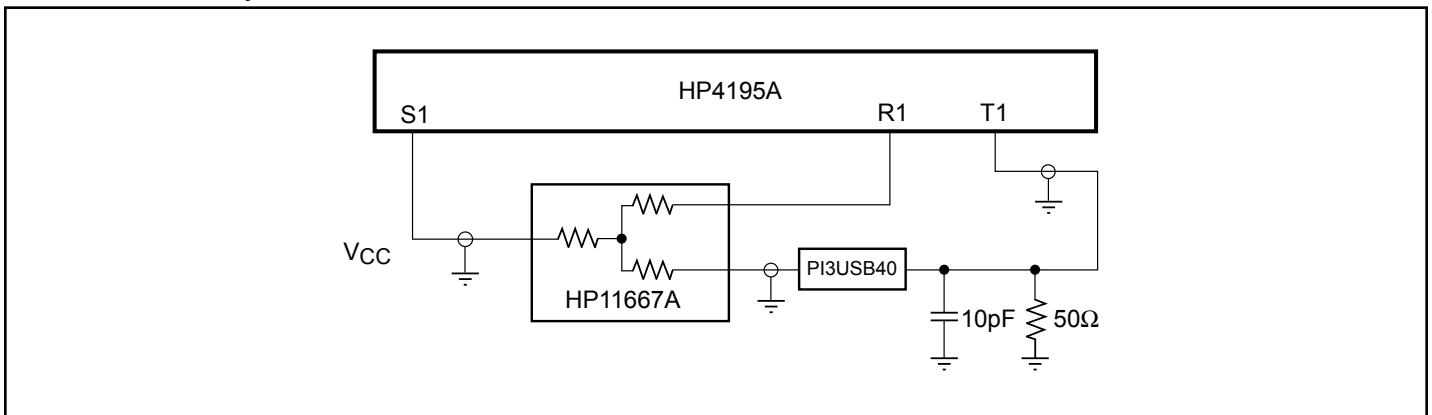

### Switching Waveforms

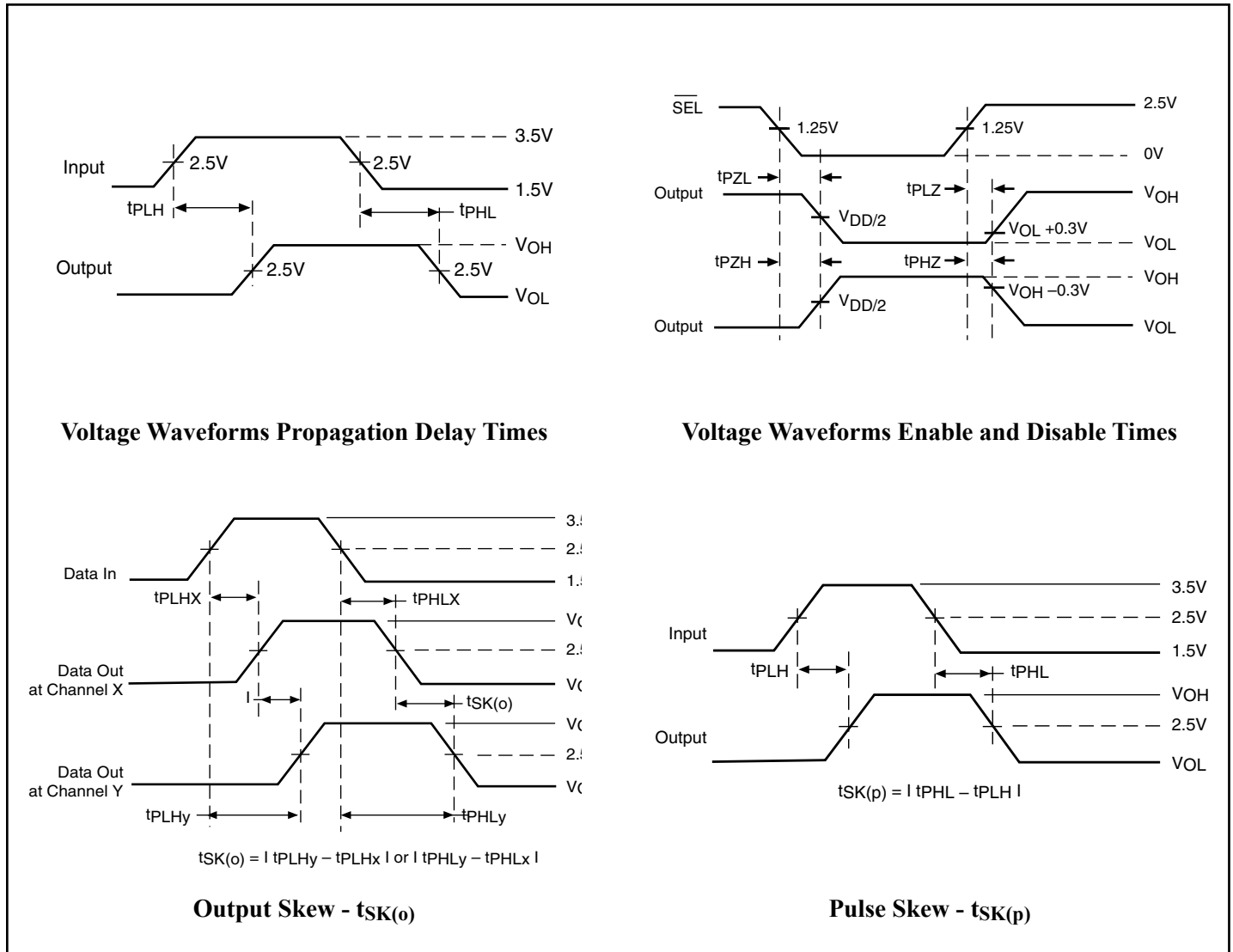

### Applications Information

#### Logic Inputs

The logic control inputs can be driven up to +3.6V regardless of the supply voltage. For example, given a +3.3V supply, the output enables or select pins may be driven low to 0V and high to 3.6V. Driving IN Rail-to-Rail® minimizes power consumption.

#### Power-Supply Sequencing

Proper power-supply sequencing is advised for all CMOS devices. It is recommended to always apply  $V_{CC}$  before applying signals to the input/output or control pins.

*Rail-to-Rail is a registered trademark of Nippon Motorola, Ltd*

**Packaging Mechanical: 48-Pin TSSOP (A)**

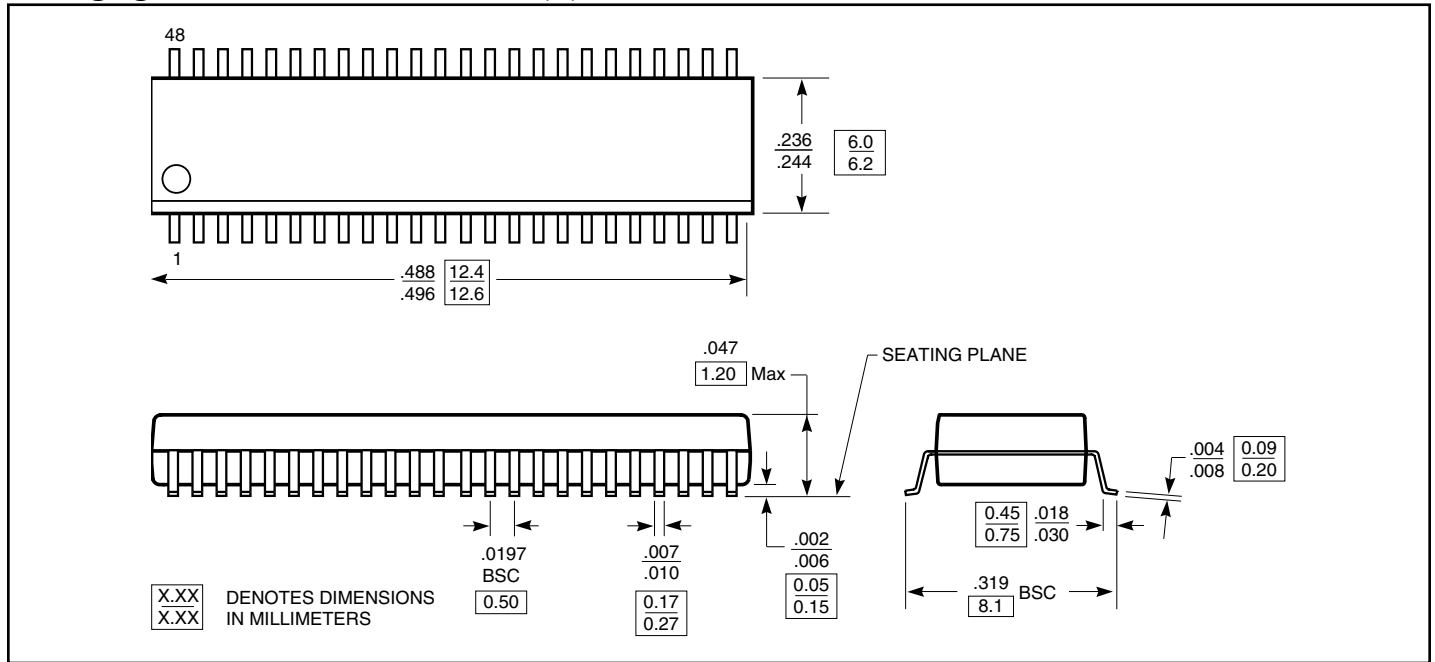

**Ordering Information**

| Ordering Code | Package Code | Package Type                                   |
|---------------|--------------|--|
| PI3USB40A     | A            | 48-pin 240 mil wide plastic TSSOP (A)          |
| PI3USB40AE    | A            | Pb-free, 48-pin 240 mil wide plastic TSSOP (A) |

**Notes:**

1. Thermal characteristics can be found on the company web site at <http://www.pericom.com/packaging/mechanicals.php>