

Hitachi Single-Chip Microcomputer

H8/338 Series

H8/338

HD6473388, HD6433388, HD6413388

H8/337

HD6473378, HD6433378, HD6413378

H8/336

HD6433368

Hardware Manual

ADE-602-039B

Rev. 3.0

September 21, 1998

Hitachi Company or Division

Cautions

1. Hitachi neither warrants nor grants licenses of any rights of Hitachi's or any third party's patent, copyright, trademark, or other intellectual property rights for information contained in this document. Hitachi bears no responsibility for problems that may arise with third party's rights, including intellectual property rights, in connection with use of the information contained in this document.
2. Products and product specifications may be subject to change without notice. Confirm that you have received the latest product standards or specifications before final design, purchase or use.
3. Hitachi makes every attempt to ensure that its products are of high quality and reliability. However, contact Hitachi's sales office before using the product in an application that demands especially high quality and reliability or where its failure or malfunction may directly threaten human life or cause risk of bodily injury, such as aerospace, aeronautics, nuclear power, combustion control, transportation, traffic, safety equipment or medical equipment for life support.
4. Design your application so that the product is used within the ranges guaranteed by Hitachi particularly for maximum rating, operating supply voltage range, heat radiation characteristics, installation conditions and other characteristics. Hitachi bears no responsibility for failure or damage when used beyond the guaranteed ranges. Even within the guaranteed ranges, consider normally foreseeable failure rates or failure modes in semiconductor devices and employ systemic measures such as fail-safes, so that the equipment incorporating Hitachi product does not cause bodily injury, fire or other consequential damage due to operation of the Hitachi product.
5. This product is not designed to be radiation resistant.
6. No one is permitted to reproduce or duplicate, in any form, the whole or part of this document without written approval from Hitachi.
7. Contact Hitachi's sales office for any questions regarding this document or Hitachi semiconductor products.

Preface

The H8/338 Series is a series of high-performance single-chip microcomputers having a fast H8/300 CPU core and a set of on-chip supporting functions optimized for embedded control. These include ROM, RAM, three types of timers, a serial communication interface, an A/D converter, a D/A converter, I/O ports, and other functions needed in control system configurations, so that compact, high-performance systems can be realized easily. The H8/338 Series includes three chips: the H8/338 with 48K-byte ROM and 2K-byte RAM; the H8/337 with 32K-byte ROM and 1K-byte RAM; and the H8/336 with 24K-byte ROM and 1K-byte RAM.

The H8/338 and H8/337 are available in a masked ROM version, a ZTAT™*(Zero Turn-Around Time) version, and a ROMless version, providing a quick and flexible response to conditions from ramp-up through full-scale volume production, even for applications with frequently-changing specifications.

This manual describes the hardware of the H8/338 Series. Refer to the H8/300 Series Programming Manual for a detailed description of the instruction set.

Note: ZTAT is a registered trademark of Hitachi, Ltd.

Contents

Section 1	Overview	1
1.1	Overview	1
1.2	Block Diagram.....	4
1.3	Pin Assignments and Functions.....	5
1.3.1	Pin Arrangement.....	5
1.3.2	Pin Functions	8
Section 2	CPU.....	15
2.1	Overview	15
2.1.1	Features.....	15
2.2	Register Configuration.....	16
2.2.1	General Registers.....	17
2.2.2	Control Registers	17
2.2.3	Initial Register Values	18
2.3	Addressing Modes	19
2.3.1	Addressing Modes	19
2.3.2	How to Calculate Where the Execution Starts	21
2.4	Data Formats.....	25
2.4.1	Data Formats in General Registers	26
2.4.2	Memory Data Formats.....	27
2.5	Instruction Set.....	28
2.5.1	Data Transfer Instructions	30
2.5.2	Arithmetic Operations	32
2.5.3	Logic Operations	33
2.5.4	Shift Operations.....	33
2.5.5	Bit Manipulations	35
2.5.6	Branching Instructions.....	39
2.5.7	System Control Instructions	41
2.5.8	Block Data Transfer Instruction	42
2.6	CPU States.....	44
2.6.1	Program Execution State	45
2.6.2	Exception-Handling State.....	45
2.6.3	Power-Down State	46
2.7	Access Timing and Bus Cycle	47
2.7.1	Access to On-Chip Memory (RAM and ROM).....	47
2.7.2	Access to On-Chip Register Field and External Devices	49
Section 3	MCU Operating Modes and Address Space.....	53
3.1	Overview	53

3.1.1	Mode Selection	53
3.1.2	Mode and System Control Registers (MDCR and SYSCR)	54
3.2	System Control Register (SYSCR)—HFFC4	54
3.3	Mode Control Register (MDCR)—HFFC5	56
3.4	Address Space Map	57
Section 4 Exception Handling.....		61
4.1	Overview	61
4.2	Reset	61
4.2.1	Overview	61
4.2.2	Reset Sequence	61
4.2.3	Disabling of Interrupts after Reset	64
4.3	Interrupts	64
4.3.1	Overview	64
4.3.2	Interrupt-Related Registers	66
4.3.3	External Interrupts	68
4.3.4	Internal Interrupts	68
4.3.5	Interrupt Handling	68
4.3.6	Interrupt Response Time	74
4.3.7	Precaution	75
4.4	Note on Stack Handling	76
Section 5 Clock Pulse Generator		77
5.1	Overview	77
5.1.1	Block Diagram	77
5.2	Oscillator Circuit	78
5.3	System Clock Divider	80
Section 6 I/O Ports.....		81
6.1	Overview	81
6.2	Port 1	84
6.3	Port 2	88
6.4	Port 3	92
6.5	Port 4	96
6.6	Port 5	100
6.7	Port 6	105
6.8	Port 7	111
6.9	Port 8	113
6.10	Port 9	119
Section 7 16-Bit Free-Running Timer		127
7.1	Overview	127
7.1.1	Features	127

7.1.2	Block Diagram.....	127
7.1.3	Input and Output Pins	129
7.1.4	Register Configuration	129
7.2	Register Descriptions.....	130
7.2.1	Free-Running Counter (FRC)—H'FF92	130
7.2.2	Output Compare Registers A and B (OCRA and OCRB)—H'FF94	131
7.2.3	Input Capture Registers A to D (ICRA to ICRD)— H'FF98, H'FF9A, H'FF9C, H'FF9E	131
7.2.4	Timer Interrupt Enable Register (TIER)—H'FF90.....	134
7.2.5	Timer Control/Status Register (TCSR)—H'FF91.....	136
7.2.6	Timer Control Register (TCR)—H'FF96.....	139
7.2.7	Timer Output Compare Control Register (TOCR)—H'FF97	141
7.3	CPU Interface	143
7.4	Operation	146
7.4.1	FRC Incrementation Timing.....	146
7.4.2	Output Compare Timing.....	148
7.4.3	Input Capture Timing	149
7.4.4	Setting of FRC Overflow Flag (OVF).....	152
7.5	Interrupts.....	152
7.6	Sample Application	153
7.7	Application Notes	154
Section 8 8-Bit Timers		159
8.1	Overview	159
8.1.1	Features.....	159
8.1.2	Block Diagram.....	160
8.1.3	Input and Output Pins	161
8.1.4	Register Configuration	161
8.2	Register Descriptions.....	162
8.2.1	Timer Counter (TCNT)—H'FFCC (TMR0), H'FFD4 (TMR1).....	162
8.2.2	Time Constant Registers A and B (TCORA and TCORB)— H'FFCA and H'FFCB (TMR0), H'FFD2 and H'FFD3 (TMR1).....	162
8.2.3	Timer Control Register (TCR)—H'FFC8 (TMR0), H'FFD0 (TMR1).....	163
8.2.4	Timer Control/Status Register (TCSR)—H'FFC9 (TMR0), H'FFD1 (TMR1)....	166
8.2.5	Serial/Timer Control Register (STCR)—H'FFC3	168
8.3	Operation	169
8.3.1	TCNT Incrementation Timing.....	169
8.3.2	Compare Match Timing.....	170
8.3.3	External Reset of TCNT	172
8.3.4	Setting of TCSR Overflow Flag (OVF).....	172
8.4	Interrupts.....	173
8.5	Sample Application	173
8.6	Application Notes	174

Section 9	PWM Timers.....	179
9.1	Overview	179
9.1.1	Features.....	179
9.1.2	Block Diagram.....	180
9.1.3	Input and Output Pins	181
9.1.4	Register Configuration	181
9.2	Register Descriptions.....	181
9.2.1	Timer Counter (TCNT)—H'FFA2 (PWM0), H'FFA6 (PWM1).....	181
9.2.2	Duty Register (DTR)—H'FFA1 (PWM0), H'FFA5 (PWM1)	182
9.2.3	Timer Control Register (TCR)—H'FFA0 (PWM0), H'FFA4 (PWM1).....	182
9.3	Operation	184
9.3.1	Timer Incrementation	184
9.3.2	PWM Operation.....	185
9.4	Application Notes	186
Section 10	Serial Communication Interface.....	187
10.1	Overview	187
10.1.1	Features.....	187
10.1.2	Block Diagram.....	188
10.1.3	Input and Output Pins	188
10.1.4	Register Configuration	189
10.2	Register Descriptions.....	190
10.2.1	Receive Shift Register (RSR)	190
10.2.2	Receive Data Register (RDR)—H'FFDD, H'FF8D	190
10.2.3	Transmit Shift Register (TSR).....	190
10.2.4	Transmit Data Register (TDR)—H'FFDB, H'FF8B	191
10.2.5	Serial Mode Register (SMR)—H'FFD8, H'FF88	191
10.2.6	Serial Control Register (SCR)—H'FFDA, H'FF8A.....	194
10.2.7	Serial Status Register (SSR)—H'FFDC, H'FF8C	197
10.2.8	Bit Rate Register (BRR)—H'FFD9, H'FF89	200
10.2.9	Serial/Timer Control Register (STCR)—H'FFC3	204
10.3	Operation	205
10.3.1	Overview	205
10.3.2	Asynchronous Mode.....	207
10.3.3	Synchronous Mode	218
10.4	Interrupts.....	224
10.5	Application Notes	224
Section 11	A/D Converter.....	227
11.1	Overview	227
11.1.1	Features.....	227
11.1.2	Block Diagram.....	228
11.1.3	Input Pins.....	229

11.1.4	Register Configuration	229
11.2	Register Descriptions.....	230
11.2.1	A/D Data Registers (ADDR)—H'FFE0 to H'FFE6	230
11.2.2	A/D Control/Status Register (ADCSR)—H'FFE8.....	230
11.2.3	A/D Control Register (ADCR)—H'FFEA	233
11.3	Operation	234
11.3.1	Single Mode (SCAN = 0)	234
11.3.2	Scan Mode (SCAN = 1).....	237
11.3.3	Input Sampling Time and A/D Conversion Time.....	239
11.3.4	External Trigger Input Timing.....	241
11.4	Interrupts.....	242
Section 12 D/A Converter.....		243
12.1	Overview	243
12.1.1	Features.....	243
12.1.2	Block Diagram.....	244
12.1.3	Input and Output Pins	245
12.1.4	Register Configuration	245
12.2	Register Descriptions.....	246
12.2.1	D/A Data Registers 0 and 1 (DADR0, DADR1) H'FFA8, H'FFA9	246
12.2.2	D/A Control Register (DACR) H'FFAA	246
12.3	Operation	248
Section 13 RAM.....		249
13.1	Overview	249
13.2	Block Diagram.....	249
13.3	RAM Enable Bit (RAME) in System Control Register (SYSCR).....	250
13.4	Operation	250
13.4.1	Expanded Modes (Modes 1 and 2)	250
13.4.2	Single-Chip Mode (Mode 3).....	250
Section 14 ROM.....		251
14.1	Overview	251
14.1.1	Block Diagram.....	252
14.2	PROM Mode (H8/338, H8/337)	252
14.2.1	PROM Mode Setup	252
14.2.2	Socket Adapter Pin Assignments and Memory Map	253
14.3	Programming	257
14.3.1	Writing and Verifying	257
14.3.2	Notes on Writing	261
14.3.3	Reliability of Written Data	262
14.3.4	Erasing of Data.....	263
14.4	Handling of Windowed Packages.....	263

Section 15	Power-Down State.....	265
15.1	Overview	265
15.2	System Control Register: Power-Down Control Bits	266
15.3	Sleep Mode	268
15.3.1	Transition to Sleep Mode.....	268
15.3.2	Exit from Sleep Mode.....	268
15.4	Software Standby Mode	269
15.4.1	Transition to Software Standby Mode	269
15.4.2	Exit from Software Standby Mode	269
15.4.3	Sample Application of Software Standby Mode	270
15.4.4	Application Note.....	271
15.5	Hardware Standby Mode	272
15.5.1	Transition to Hardware Standby Mode.....	272
15.5.2	Recovery from Hardware Standby Mode	272
15.5.3	Timing Relationships.....	272
Section 16	Electrical Specifications.....	275
16.1	Absolute Maximum Ratings	275
16.2	Electrical Characteristics	275
16.2.1	DC Characteristics.....	275
16.2.2	AC Characteristics.....	281
16.2.3	A/D Converter Characteristics.....	286
16.2.4	D/A Converter Characteristics.....	287
16.3	MCU Operational Timing.....	287
16.3.1	Bus Timing	288
16.3.2	Control Signal Timing	290
16.3.3	16-Bit Free-Running Timer Timing	292
16.3.4	8-Bit Timer Timing	293
16.3.5	Pulse Width Modulation Timer Timing.....	294
16.3.6	Serial Communication Interface Timing	294
16.3.7	I/O Port Timing	295
Appendix A	CPU Instruction Set	297
A.1	Instruction Set List.....	297
A.2	Operation Code Map.....	305
A.3	Number of States Required for Execution	307
Appendix B	Register Field.....	313
B.1	Register Addresses and Bit Names	313
B.2	Register Descriptions.....	317

Appendix C	Pin States.....	356
C.1	Pin States in Each Mode.....	356
Appendix D	Timing of Transition to and Recovery from Hardware Standby Mode.....	358
Appendix E	Package Dimensions.....	359

Section 1 Overview

1.1 Overview

The H8/338 Series of single-chip microcomputers features an H8/300 CPU core and a complement of on-chip supporting modules implementing a variety of system functions.

The H8/300 CPU is a high-speed processor with an architecture featuring powerful bit-manipulation instructions, ideally suited for realtime control applications. The on-chip supporting modules implement peripheral functions needed in system configurations. These include ROM, RAM, three types of timers (16-bit free-running timer, 8-bit timers, pulse-width modulation timers), a serial communication interface (SCI), an A/D converter, a D/A converter, and I/O ports.

The H8/338 Series can operate in a single-chip mode or in two expanded modes, depending on the requirements of the application. (The operating mode will be referred to as the MCU mode in this manual.)

The entire H8/338 Series is available with masked ROM. The H8/338 and H8/337 are also available in ZTAT™ versions* that can be programmed at the user site, and in ROMless versions.

Note: ZTAT is a registered trademark of Hitachi, Ltd.

Table 1.1 lists the features of the H8/338 Series.

Table 1.1 Features

Item	Specification
CPU	<p>Two-way general register configuration</p> <ul style="list-style-type: none">• Eight 16-bit registers, or• Sixteen 8-bit registers <p>High-speed operation</p> <ul style="list-style-type: none">• Maximum clock rate: 10MHz• Add/subtract: 0.2μs• Multiply/divide: 1.4μs <p>Streamlined, concise instruction set</p> <ul style="list-style-type: none">• Instruction length: 2 or 4 bytes• Register-register arithmetic and logic operations• MOV instruction for data transfer between registers and memory <p>Instruction set features</p> <ul style="list-style-type: none">• Multiply instruction (8 bits \times 8 bits)• Divide instruction (16 bits \div 8 bits)• Bit-accumulator instructions• Register-indirect specification of bit positions
Memory	<ul style="list-style-type: none">• H8/338: 48k-byte ROM; 2k-byte RAM• H8/337: 32k-byte ROM; 1k-byte RAM• H8/336: 24k-byte ROM; 1k-byte RAM
16-bit free-running timer (1 channel)	<ul style="list-style-type: none">• One 16-bit free-running counter (can also count external events)• Two output-compare lines• Four input capture lines (can be buffered)
8-bit timer (2 channels)	<p>Each channel has</p> <ul style="list-style-type: none">• One 8-bit up-counter (can also count external events)• Two time constant registers
PWM timer (2 channels)	<ul style="list-style-type: none">• Duty cycle can be set from 0 to 100%• Resolution: 1/250
Serial communication interface (SCI) (2 channels)	<ul style="list-style-type: none">• Asynchronous or clocked synchronous mode (selectable)• Full duplex: can transmit and receive simultaneously• On-chip baud rate generator

Table 1.1 Features (cont)

Item	Specification
A/D converter	<ul style="list-style-type: none"> • 8-bit resolution • Eight channels: single or scan mode (selectable) • Start of A/D conversion can be externally triggered • Sample-and-hold function
D/A converter	<ul style="list-style-type: none"> • 8-bit resolution • Two channels
I/O ports	<ul style="list-style-type: none"> • 58 input/output lines (16 of which can drive LEDs) • 8 input-only lines
Interrupts	<ul style="list-style-type: none"> • Nine external interrupt lines: NMI, $\overline{\text{IRQ}}_0$ to $\overline{\text{IRQ}}_7$ • 22 on-chip interrupt sources
Operating modes	<ul style="list-style-type: none"> • Expanded mode with on-chip ROM disabled (mode 1) • Expanded mode with on-chip ROM enabled (mode 2) • Single-chip mode (mode 3)
Power-down modes	<ul style="list-style-type: none"> • Sleep mode • Software standby mode • Hardware standby mode
Other features	<ul style="list-style-type: none"> • On-chip oscillator

Series lineup				
	5-V version	3-V version	Package	ROM
	HD6473388CG	HD6473388VCG	84-pin windowed LCC (CG-84)	PROM
	HD6473388F	HD6473388VF	80-pin QFP (FP-80A)	
	HD6433388CP	HD6433388VCP	84-pin PLCC (CP-84)	Masked ROM
	HD6433388F	HD6433388VF	80-pin QFP (FP-80A)	
	HD6413388F	HD6413388VF	80-pin QFP (FP-80A)	ROMless
	HD6473378CG	HD6473378VCG	84-pin windowed LCC (CG-84)	PROM
	HD6473378F	HD6473378VF	80-pin QFP (FP-80A)	
	HD6433378CP	HD6433378VCP	84-pin PLCC (CP-84)	Masked ROM
	HD6433378F	HD6433378VF	80-pin QFP (FP-80A)	
	HD6413378F	HD6413378VF	80-pin QFP (FP-80A)	ROMless
	HD6433368CP	HD6433368VCP	84-pin PLCC (CP-84)	Masked ROM
	HD6433368F	HD6433368VF	80-pin QFP (FP-80A)	

1.2 Block Diagram

Figure 1.1 shows a block diagram of the H8/338 Series.

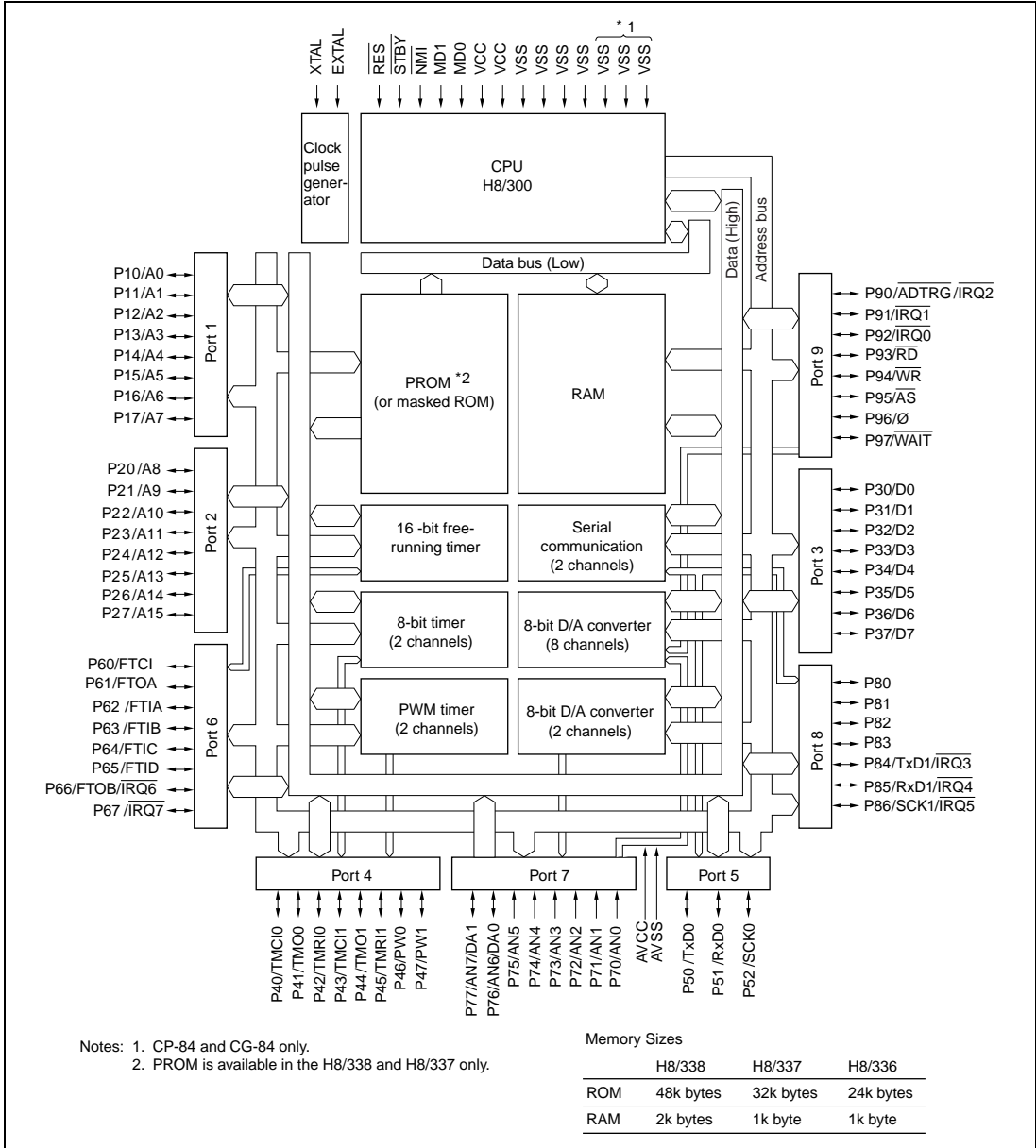

Figure 1.1 Block Diagram

1.3 Pin Assignments and Functions

1.3.1 Pin Arrangement

Figure 1.2 shows the pin arrangement of the CG-84 package. Figure 1.3 shows the pin arrangement of the CP-84 package. Figure 1.4 shows the pin arrangement of the FP-80A package.

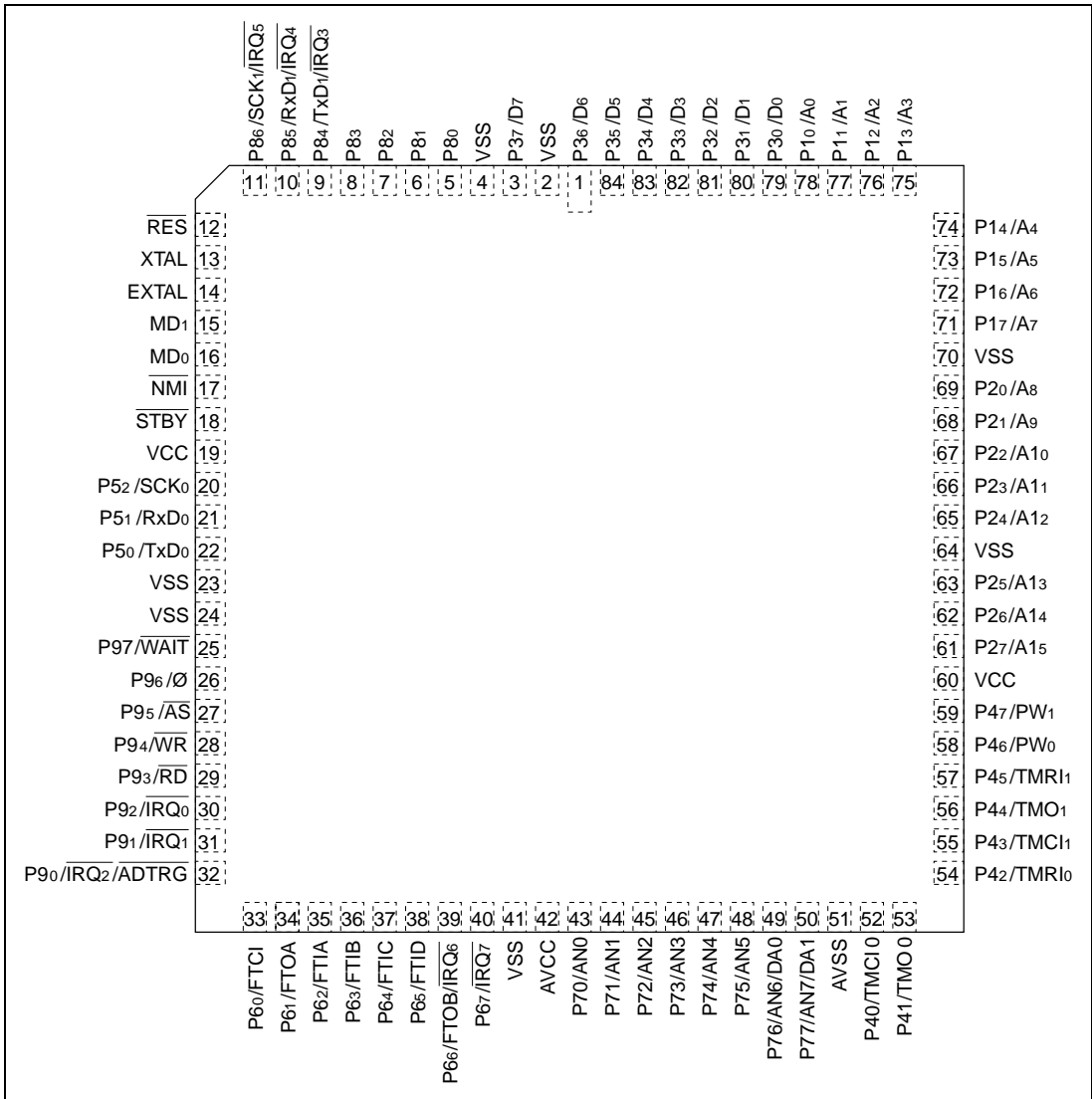

Figure 1.2 Pin Arrangement (CG-84, Top view)

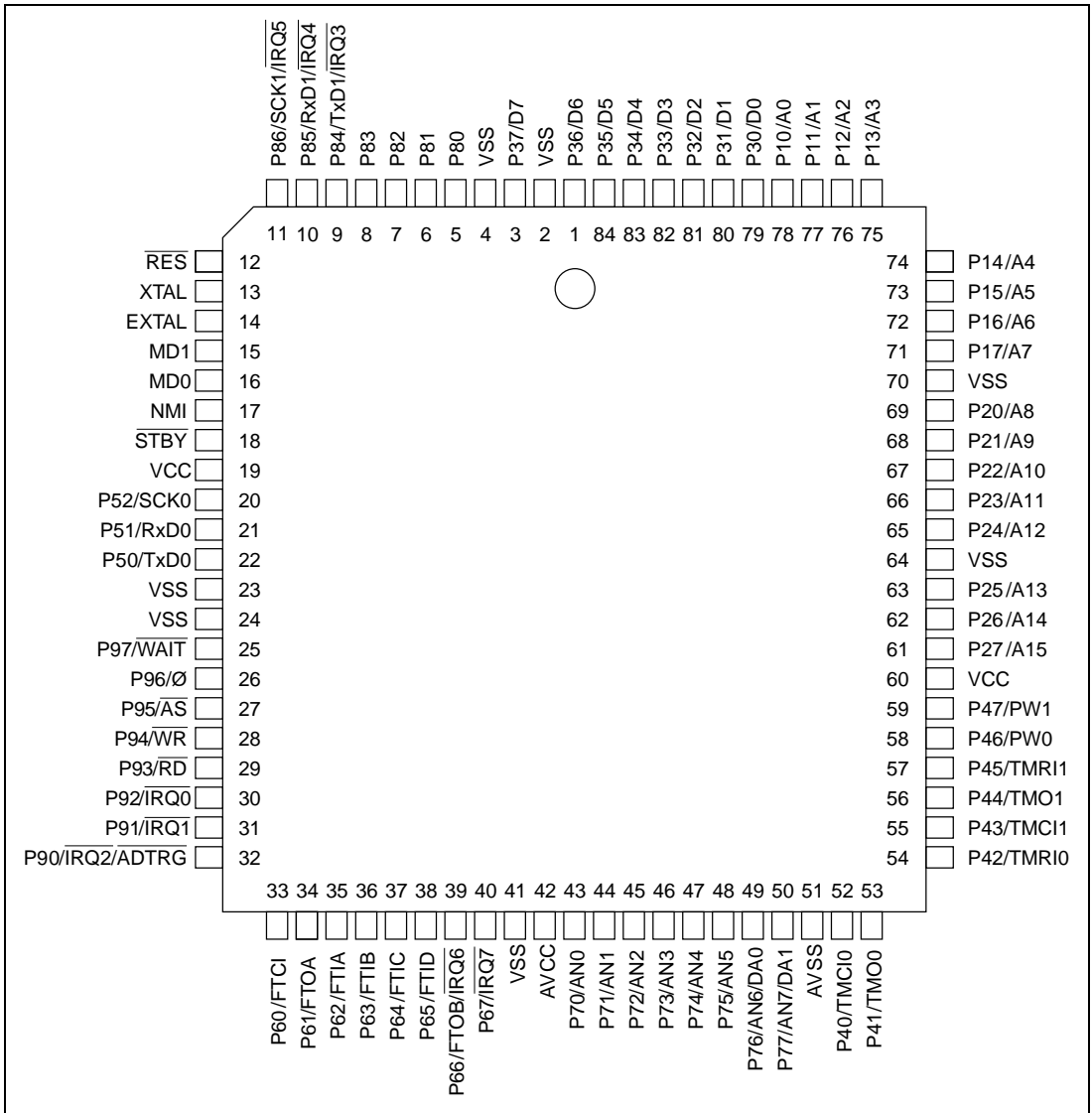

Figure 1.3 Pin Arrangement (CP-84, Top view)

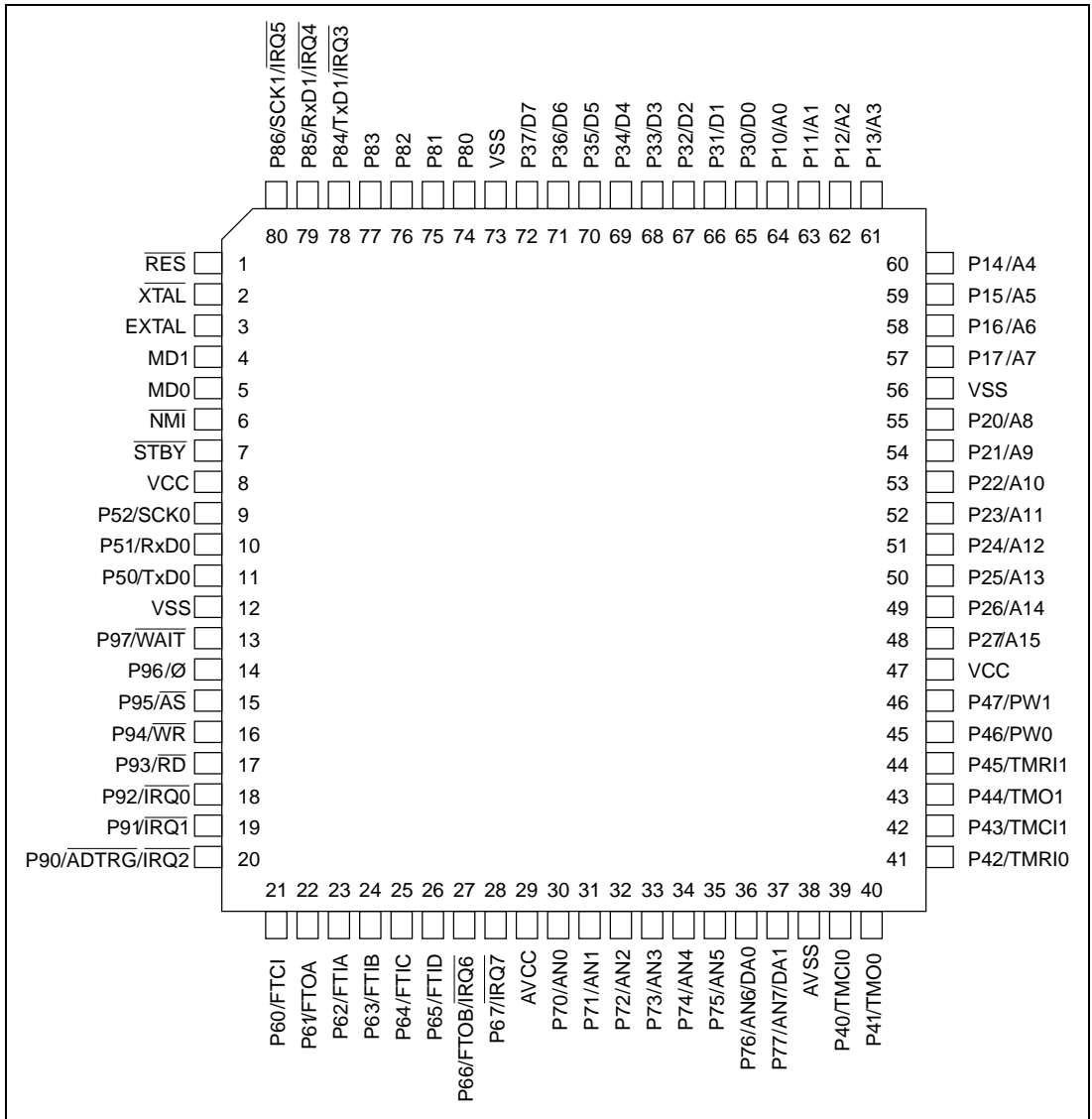

Figure 1.4 Pin Arrangement (FP-80A, Top view)

1.3.2 Pin Functions

(1) **Pin Assignments in Each Operating Mode:** Table 1.2 lists the assignments of the pins of the FP-80A, CP-84, and CG-84 packages in each operating mode.

Table 1.2 Pin Assignments in Each Operating Mode

Pin No.		Expanded Modes		Single-Chip Mode	
CP-84 CG-84	FP-80A	Mode 1	Mode 2	Mode 3	PROM Mode
1	71	D ₆	D ₆	P3 ₆	EO ₆
2	—	V _{SS}	V _{SS}	V _{SS}	V _{SS}
3	72	D ₇	D ₇	P3 ₇	EO ₇
4	73	V _{SS}	V _{SS}	V _{SS}	V _{SS}
5	74	P8 ₀	P8 ₀	P8 ₀	NC
6	75	P8 ₁	P8 ₁	P8 ₁	NC
7	76	P8 ₂	P8 ₂	P8 ₂	NC
8	77	P8 ₃	P8 ₃	P8 ₃	NC
9	78	P8 ₄ / TxD ₁ / $\overline{\text{IRQ}}_3$	P8 ₄ / TxD ₁ / $\overline{\text{IRQ}}_3$	P8 ₄ / TxD ₁ / $\overline{\text{IRQ}}_3$	NC
10	79	P8 ₅ / RxD ₁ / $\overline{\text{IRQ}}_4$	P8 ₅ / RxD ₁ / $\overline{\text{IRQ}}_4$	P8 ₅ / RxD ₁ / $\overline{\text{IRQ}}_4$	NC
11	80	P8 ₆ / SCK ₁ / $\overline{\text{IRQ}}_5$	P8 ₆ / SCK ₁ / $\overline{\text{IRQ}}_5$	P8 ₆ / SCK ₁ / $\overline{\text{IRQ}}_5$	NC
12	1	$\overline{\text{RES}}$	$\overline{\text{RES}}$	$\overline{\text{RES}}$	V _{PP}
13	2	XTAL	XTAL	XTAL	NC
14	3	EXTAL	EXTAL	EXTAL	NC
15	4	MD ₁	MD ₁	MD ₁	V _{SS}
16	5	MD ₀	MD ₀	MD ₀	V _{SS}
17	6	$\overline{\text{NMI}}$	$\overline{\text{NMI}}$	$\overline{\text{NMI}}$	EA ₉
18	7	$\overline{\text{STBY}}$	$\overline{\text{STBY}}$	$\overline{\text{STBY}}$	V _{SS}
19	8	V _{CC}	V _{CC}	V _{CC}	V _{CC}
20	9	P5 ₂ / SCK ₀	P5 ₂ / SCK ₀	P5 ₂ / SCK ₀	NC
21	10	P5 ₁ / RxD ₀	P5 ₁ / RxD ₀	P5 ₁ / RxD ₀	NC
22	11	P5 ₀ / TxD ₀	P5 ₀ / TxD ₀	P5 ₀ / TxD ₀	NC
23	12	V _{SS}	V _{SS}	V _{SS}	V _{SS}
24	—	V _{SS}	V _{SS}	V _{SS}	V _{SS}
25	13	$\overline{\text{WAIT}}$	$\overline{\text{WAIT}}$	P9 ₇	NC

Note: Pins marked NC should be left unconnected.

For details on PROM mode, refer to 14.2, "PROM Mode."

Table 1.2 Pin Assignments in Each Operating Mode (cont)

Pin No.		Expanded Modes		Single-Chip Mode	PROM Mode
CP-84 CG-84	FP-80A	Mode 1	Mode 2	Mode 3	
26	14	ϕ	ϕ	P9 ₆ / ϕ	NC
27	15	\overline{AS}	\overline{AS}	P9 ₅	NC
28	16	\overline{WR}	\overline{WR}	P9 ₄	NC
29	17	\overline{RD}	\overline{RD}	P9 ₃	NC
30	18	P9 ₂ / $\overline{IRQ_0}$	P9 ₂ / $\overline{IRQ_0}$	P9 ₂ / $\overline{IRQ_0}$	PGM
31	19	P9 ₁ / $\overline{IRQ_1}$	P9 ₁ / $\overline{IRQ_1}$	P9 ₁ / $\overline{IRQ_1}$	EA15
32	20	P9 ₀ / \overline{ADTRG} / $\overline{IRQ_2}$	P9 ₀ / \overline{ADTRG} / $\overline{IRQ_2}$	P9 ₀ / \overline{ADTRG} / $\overline{IRQ_2}$	EA16
33	21	P6 ₀ / FTCl	P6 ₀ / FTCl	P6 ₀ / FTCl	NC
34	22	P6 ₁ / FTOA	P6 ₁ / FTOA	P6 ₁ / FTOA	NC
35	23	P6 ₂ / FTIA	P6 ₂ / FTIA	P6 ₂ / FTIA	NC
36	24	P6 ₃ / FTIB	P6 ₃ / FTIB	P6 ₃ / FTIB	V _{CC}
37	25	P6 ₄ / FTIC	P6 ₄ / FTIC	P6 ₄ / FTIC	V _{CC}
38	26	P6 ₅ / FTID	P6 ₅ / FTID	P6 ₅ / FTID	NC
39	27	P6 ₆ / FTOb / $\overline{IRQ_6}$	P6 ₆ / FTOb / $\overline{IRQ_6}$	P6 ₆ / FTOb / $\overline{IRQ_6}$	NC
40	28	P6 ₇ / $\overline{IRQ_7}$	P6 ₇ / $\overline{IRQ_7}$	P6 ₇ / $\overline{IRQ_7}$	NC
41	—	V _{SS}	V _{SS}	V _{SS}	V _{SS}
42	29	AV _{CC}	AV _{CC}	AV _{CC}	V _{CC}
43	30	P7 ₀ / AN ₀	P7 ₀ / AN ₀	P7 ₀ / AN ₀	NC
44	31	P7 ₁ / AN ₁	P7 ₁ / AN ₁	P7 ₁ / AN ₁	NC
45	32	P7 ₂ / AN ₂	P7 ₂ / AN ₂	P7 ₂ / AN ₂	NC
46	33	P7 ₃ / AN ₃	P7 ₃ / AN ₃	P7 ₃ / AN ₃	NC
47	34	P7 ₄ / AN ₄	P7 ₄ / AN ₄	P7 ₄ / AN ₄	NC
48	35	P7 ₅ / AN ₅	P7 ₅ / AN ₅	P7 ₅ / AN ₅	NC
49	36	P7 ₆ / AN ₆ / DA ₀	P7 ₆ / AN ₆ / DA ₀	P7 ₆ / AN ₆ / DA ₀	NC
50	37	P7 ₇ / AN ₇ / DA ₁	P7 ₇ / AN ₇ / DA ₁	P7 ₇ / AN ₇ / DA ₁	NC
51	38	AV _{SS}	AV _{SS}	AV _{SS}	V _{SS}
52	39	P4 ₀ / TMCl ₀	P4 ₀ / TMCl ₀	P4 ₀ / TMCl ₀	NC
53	40	P4 ₁ / TMO ₀	P4 ₁ / TMO ₀	P4 ₁ / TMO ₀	NC
54	41	P4 ₂ / TMRl ₀	P4 ₂ / TMRl ₀	P4 ₂ / TMRl ₀	NC

Note: Pins marked NC should be left unconnected.

For details on PROM mode, refer to 14.2, "PROM Mode."

Table 1.2 Pin Assignments in Each Operating Mode (cont)

Pin No.		Expanded Modes		Single-Chip Mode		
CP-84	CG-84	FP-80A	Mode 1	Mode 2	Mode 3	PROM Mode
55	42		P4 ₃ / TMCI ₁	P4 ₃ / TMCI ₁	P4 ₃ / TMCI ₁	NC
56	43		P4 ₄ / TMO ₁	P4 ₄ / TMO ₁	P4 ₄ / TMO ₁	NC
57	44		P4 ₅ / TMRI ₁	P4 ₅ / TMRI ₁	P4 ₅ / TMRI ₁	NC
58	45		P4 ₆ / PW ₀	P4 ₆ / PW ₀	P4 ₆ / PW ₀	NC
59	46		P4 ₇ / PW ₁	P4 ₇ / PW ₁	P4 ₇ / PW ₁	NC
60	47		V _{CC}	V _{CC}	V _{CC}	V _{CC}
61	48		A ₁₅	P2 ₇ / A ₁₅	P2 ₇	\overline{CE}
62	49		A ₁₄	P2 ₆ / A ₁₄	P2 ₆	EA ₁₄
63	50		A ₁₃	P2 ₅ / A ₁₃	P2 ₅	EA ₁₃
64	—		V _{SS}	V _{SS}	V _{SS}	V _{SS}
65	51		A ₁₂	P2 ₄ / A ₁₂	P2 ₄	EA ₁₂
66	52		A ₁₁	P2 ₃ / A ₁₁	P2 ₃	EA ₁₁
67	53		A ₁₀	P2 ₂ / A ₁₀	P2 ₂	EA ₁₀
68	54		A ₉	P2 ₁ / A ₉	P2 ₁	\overline{OE}
69	55		A ₈	P2 ₀ / A ₈	P2 ₀	EA ₈
70	56		V _{SS}	V _{SS}	V _{SS}	V _{SS}
71	57		A ₇	P1 ₇ / A ₇	P1 ₇	EA ₇
72	58		A ₆	P1 ₆ / A ₆	P1 ₆	EA ₆
73	59		A ₅	P1 ₅ / A ₅	P1 ₅	EA ₅
74	60		A ₄	P1 ₄ / A ₄	P1 ₄	EA ₄
75	61		A ₃	P1 ₃ / A ₃	P1 ₃	EA ₃
76	62		A ₂	P1 ₂ / A ₂	P1 ₂	EA ₂
77	63		A ₁	P1 ₁ / A ₁	P1 ₁	EA ₁
78	64		A ₀	P1 ₀ / A ₀	P1 ₀	EA ₀
79	65		D ₀	D ₀	P3 ₀	EO ₀
80	66		D ₁	D ₁	P3 ₁	EO ₁
81	67		D ₂	D ₂	P3 ₂	EO ₂
82	68		D ₃	D ₃	P3 ₃	EO ₃
83	69		D ₄	D ₄	P3 ₄	EO ₄
84	70		D ₅	D ₅	P3 ₅	EO ₅

Note: Pins marked NC should be left unconnected.

For details on PROM mode, refer to 14.2, "PROM Mode."

(2) **Pin Functions:** Table 1.3 gives a concise description of the function of each pin.

Table 1.3 Pin Functions

Type	Symbol	Pin No.			Name and Function
		CG-84 CP-84	FP-80A	I/O	
Power	V _{CC}	19, 60	8, 47	I	Power: Connected to the power supply (+5V). Connect both VCC pins to the system power supply (+5V).
	V _{SS}	2, 4, 23, 24, 41, 64, 70	12, 56, 73	I	Ground: Connected to ground (0V). Connect all VSS pins to the system power supply (0V).
Clock	XTAL	13	2	I	Crystal: Connected to a crystal oscillator. The crystal frequency should be double the desired system clock frequency
	EXTAL	14	3	I	External crystal: Connected to a crystal oscillator or external clock. The frequency of the external clock should be double the desired system clock frequency. See section 15.2, "Oscillator Circuit," for examples of connections to a crystal and external clock.
	∅	26	14	O	System clock: Supplies the system clock to peripheral devices.
System control	$\overline{\text{RES}}$	12	1	I	Reset: A Low input causes the chip to reset.
	$\overline{\text{STBY}}$	18	7	I	Standby: A transition to the hardware standby mode (a power-down state) occurs when a Low input is received at the STBY pin.
Address bus	A ₁₅ to A ₀	61 to 63, 65 to 69, 71 to 78	48 to 55, 57 to 64	O	Address bus: Address output pins.
Data bus	D ₇ to D ₀	3, 1, 84 to 79	72 to 65	I/O	Data bus: 8-Bit bidirectional data bus.

Table 1.3 Pin Functions (cont)

Type	Symbol	Pin No.		I/O	Name and Function
		CG-84 CP-84	FP-80A		
Bus control	$\overline{\text{WAIT}}$	25	13	I	Wait: Requests the CPU to insert TW states into the bus cycle when an external address is accessed.
	$\overline{\text{RD}}$	29	17	O	Read: Goes Low to indicate that the CPU is reading an external address.
	$\overline{\text{WR}}$	28	16	O	Write: Goes Low to indicate that the CPU is writing to an external address.
	$\overline{\text{AS}}$	27	15	O	Address Strobe: Goes Low to indicate that there is a valid address on the address bus.
Interrupt signals	$\overline{\text{NMI}}$	17	6	I	NonMaskable Interrupt: Highest-priority interrupt request. The NMIEG bit in the system control register determines whether the interrupt is requested on the rising or falling edge of the NMI input.
	$\overline{\text{IRQ}}_0$ to $\overline{\text{IRQ}}_7$	30 to 32, 9 to 11, 39, 40	18 to 20, 78 to 80, 27, 28	I	Interrupt Request 0 to 7: Maskable interrupt request pins.
Operating mode control	MD_1 , MD_0	15 16	4 5	I	Mode: Input pins for setting the MCU operating mode according to the table below.
	MD₁	MD₀	Mode	Description	
	0	0	Mode 0	Setting prohibited	
	0	1	Mode 1	Expanded mode with on-chip ROM disabled	
	1	0	Mode 2	Expanded mode with on-chip ROM enabled	
	1	1	Mode 3	Single-chip mode	
	These pins must not be changed during MCU operation.				
Serial communication interface	TxD_0 , TxD_1	22 9	11 78	O	Transmit Data (channels 0 and 1): Data output pins for the serial communication interface.
	RxD_0 , RxD_1	21 10	10 79	I	Receive Data (channels 0 and 1): Data input pins for the serial communication interface.
	SCK_0 , SCK_1	20 11	9 80	I/O	Serial Clock (channels 0 and 1): Input/output pins for the serial clock.

Table 1.3 Pin Functions (cont)

Type	Symbol	Pin No.			Name and Function
		CG-84 CP-84	FP-80A	I/O	
16-bit free-running timer	FTOA, FTOB	34 39	22 27	O	FRT Output compare A and B: Output pins controlled by comparators A and B of the free-running timer.
	FTCI	33	21	I	FRT counter Clock Input: Input pin for an external clock signal for the free-running timer.
	FTIA to FTID	35 to 38	23 to 26	I	FRT Input capture A to D: Input capture pins for the free-running timer.
8-bit timer	TMO ₀ , TMO ₁	53 56	40 43	O	8-bit Timer Output (channels 0 and 1): Compare-match output pins for the 8-bit timers.
	TMCI ₀ , TMCI ₁	52 55	39 42	I	8-bit Timer counter Clock Input (channels 0 and 1): External clock input pins for the 8-bit timer counters.
	TMRI ₀ , TMRI ₁	54 57	41 44	I	8-bit Timer counter Reset Input (channels 0 and 1): A High input at these pins resets the 8-bit timer counters.
	PWM timer	PW ₀ , PW ₁	58 59	45 46	O
A/D converter	AN ₇ to AN ₀	50 to 43	37 to 30	I	Analog input: Analog signal input pins for the A/D converter.
	ADTRG	32	20	I	A/D Trigger: External trigger input for starting the A/D converter.
D/A converter	DA ₀ DA ₁	49 50	36 37	O	Analog output: Analog signal output pins for the D/A converter.
A/D and D/A converters	AV _{CC}	42	29	I	Analog reference Voltage: Reference voltage pin for the A/D and D/A converters. If the A/D and D/A converters are not used, connect AVCC to the system power supply (+5V).
	AV _{SS}	51	38	I	Analog ground: Ground pin for the A/D and D/A converters. Connect to system ground (0V).

Table 1.3 Pin Functions (cont)

Type	Symbol	Pin No.		I/O	Name and Function
		CG-84 CP-84	FP-80A		
General-purpose I/O	P1 ₇ to P1 ₀	71 to 78	57 to 64	I/O	Port 1: An 8-bit input/output port with programmable MOS input pull-ups and LED driving capability. The direction of each bit can be selected in the port 1 data direction register (P1DDR).
	P2 ₇ to P2 ₀	61 to 63, 65 to 69	48 to 55	I/O	Port 2: An 8-bit input/output port with programmable MOS input pull-ups and LED driving capability. The direction of each bit can be selected in the port 2 data direction register (P2DDR).
	P3 ₇ to P3 ₀	3, 1, 84 to 79	72 to 65	I/O	Port 3: An 8-bit input/output port with programmable MOS input pull-ups. The direction of each bit can be selected in the port 3 data direction register (P3DDR).
	P4 ₇ to P4 ₀	59 to 52	46 to 39	I/O	Port 4: An 8-bit input/output port. The direction of each bit can be selected in the port 4 data direction register (P4DDR).
	P5 ₂ to P5 ₀	20 to 22	9 to 11	I/O	Port 5: A 3-bit input/output port. The direction of each bit can be selected in the port 5 data direction register (P5DDR).
	P6 ₇ to P6 ₀	40 to 33	28 to 21	I/O	Port 6: An 8-bit input/output port. The direction of each bit can be selected in the port 6 data direction register (P6DDR).
	P7 ₇ to P7 ₀	50 to 43	37 to 30	I	Port 7: An 8-bit input port.
	P8 ₆ to P8 ₀	11 to 5	80 to 74	I/O	Port 8: A 7-bit input/output port. The direction of each bit can be selected in the port 8 data direction register (P8DDR).
	P9 ₇ to P9 ₀	25 to 32	13 to 20	I/O	Port 9: An 8-bit input/output port. The direction of each bit (except for P96) can be selected in the port 9 data direction register (P9DDR).

Section 2 CPU

2.1 Overview

The H8/338 Series has the H8/300 CPU: a fast central processing unit with eight 16-bit general registers (also configurable as 16 eight-bit registers) and a concise instruction set designed for high-speed operation.

2.1.1 Features

The main features of the H8/300 CPU are listed below.

- Two-way register configuration
 - Sixteen 8-bit general registers, or
 - Eight 16-bit general registers
- Instruction set with 57 basic instructions, including:
 - Multiply and divide instructions
 - Powerful bit-manipulation instructions
- Eight addressing modes
 - Register direct (Rn)
 - Register indirect (@Rn)
 - Register indirect with displacement (@(d:16, Rn))
 - Register indirect with post-increment or pre-decrement (@Rn+ or @-Rn)
 - Absolute address (@aa:8 or @aa:16)
 - Immediate (#xx:8 or #xx:16)
 - PC-relative (@(d:8, PC))
 - Memory indirect (@@aa:8)
- Maximum 64K-byte address space
- High-speed operation
 - All frequently-used instructions are executed in two to four states
 - The maximum clock rate is 10MHz
 - 8- or 16-bit register-register add or subtract: 0.2 μ s
 - 8 \times 8-bit multiply: 1.4 μ s
 - 16 \div 8-bit divide: 1.4 μ s
- Power-down mode
 - SLEEP instruction

2.2 Register Configuration

Figure 2.1 shows the register structure of the CPU. There are two groups of registers: the general registers and control registers.

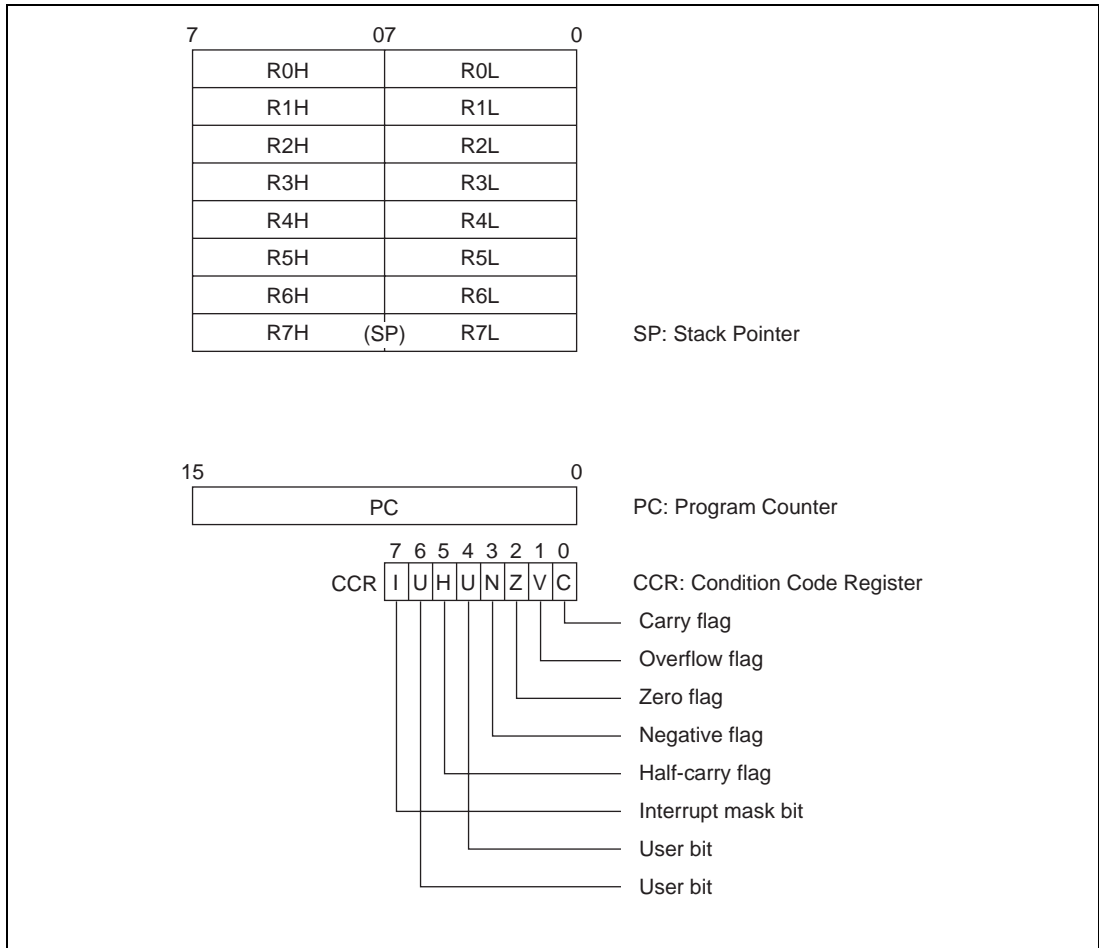

Figure 2.1 CPU Registers

2.2.1 General Registers

All the general registers can be used as both data registers and address registers. When used as address registers, the general registers are accessed as 16-bit registers (R0 to R7). When used as data registers, they can be accessed as 16-bit registers, or the high and low bytes can be accessed separately as 8-bit registers (R0H to R7H and R0L to R7L).

R7 also functions as the stack pointer, used implicitly by hardware in processing interrupts and subroutine calls. In assembly-language coding, R7 can also be denoted by the letters SP. As indicated in figure 2.2, R7 (SP) points to the top of the stack.

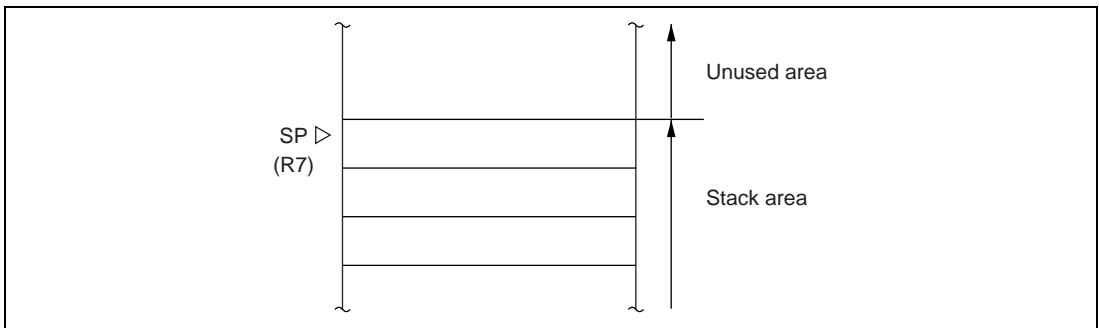

Figure 2.2 Stack Pointer

2.2.2 Control Registers

The CPU control registers include a 16-bit program counter (PC) and an 8-bit condition code register (CCR).

(1) Program Counter (PC): This 16-bit register indicates the address of the next instruction the CPU will execute. Each instruction is accessed in 16 bits (1 word), so the least significant bit of the PC is ignored (always regarded as 0).

(2) Condition Code Register (CCR): This 8-bit register contains internal status information, including carry (C), overflow (V), zero (Z), negative (N), and half-carry (H) flags and the interrupt mask bit (I).

Bit 7—Interrupt Mask Bit (I): When this bit is set to “1,” all interrupts except NMI are masked. This bit is set to “1” automatically by a reset and at the start of interrupt handling.

Bit 6—User Bit (U): This bit can be written and read by software (using the LDC, STC, ANDC, ORC, and XORC instructions).

Bit 5—Half-Carry Flag (H): This flag is set to “1” when the ADD.B, ADDX.B, SUB.B, SUBX.B, NEG.B, or CMP.B instruction causes a carry or borrow out of bit 3, and is cleared to

“0” otherwise. Similarly, it is set to “1” when the ADD.W, SUB.W, or CMP.W instruction causes a carry or borrow out of bit 11, and cleared to “0” otherwise. It is used implicitly in the DAA and DAS instructions.

Bit 4—User Bit (U): This bit can be written and read by software (using the LDC, STC, ANDC, ORC, and XORC instructions).

Bit 3—Negative Flag (N): This flag indicates the most significant bit (sign bit) of the result of an instruction.

Bit 2—Zero Flag (Z): This flag is set to “1” to indicate a zero result and cleared to “0” to indicate a nonzero result.

Bit 1—Overflow Flag (V): This flag is set to “1” when an arithmetic overflow occurs, and cleared to “0” at other times.

Bit 0—Carry Flag (C): This flag is used by:

- Add and subtract instructions, to indicate a carry or borrow at the most significant bit of the result
- Shift and rotate instructions, to store the value shifted out of the most significant or least significant bit
- Bit manipulation and bit load instructions, as a bit accumulator

The LDC, STC, ANDC, ORC, and XORC instructions enable the CPU to load and store the CCR, and to set or clear selected bits by logic operations. The N, Z, V, and C flags are used in conditional branching instructions (B_{CC}).

For the action of each instruction on the flag bits, see the *H8/300 Series Programming Manual*.

2.2.3 Initial Register Values

When the CPU is reset, the program counter (PC) is loaded from the vector table and the interrupt mask bit (I) in the CCR is set to “1.” The other CCR bits and the general registers are not initialized.

In particular, the stack pointer (R7) is not initialized. To prevent program crashes the stack pointer should be initialized by software, by the first instruction executed after a reset.

2.3 Addressing Modes

2.3.1 Addressing Mode

The H8/300 CPU supports eight addressing modes. Each instruction uses a subset of these addressing modes.

Table 2.1 Addressing Modes

No.	Addressing mode	Symbol
(1)	Register direct	Rn
(2)	Register indirect	@Rn
(3)	Register indirect with displacement	@(d:16, Rn)
(4)	Register indirect with post-increment Register indirect with pre-decrement	@Rn+ @-Rn
(5)	Absolute address	@aa:8 or @aa:16
(6)	Immediate	#xx:8 or #xx:16
(7)	Program-counter-relative	@(d:8, PC)
(8)	Memory indirect	@@aa:8

(1) Register Direct—Rn: The register field of the instruction specifies an 8- or 16-bit general register containing the operand. In most cases the general register is accessed as an 8-bit register. Only the MOV.W, ADD.W, SUB.W, CMP.W, ADDS, SUBS, MULXU (8 bits × 8 bits), and DIVXU (16 bits ÷ 8 bits) instructions have 16-bit operands.

(2) Register indirect—@Rn: The register field of the instruction specifies a 16-bit general register containing the address of the operand.

(3) Register Indirect with Displacement—@(d:16, Rn): This mode, which is used only in MOV instructions, is similar to register indirect but the instruction has a second word (bytes 3 and 4) which is added to the contents of the specified general register to obtain the operand address. For the MOV.W instruction, the resulting address must be even.

(4) Register Indirect with Post-Increment or Pre-Decrement—@Rn+ or @-Rn:

- Register indirect with Post-Increment—@Rn+

The @Rn+ mode is used with MOV instructions that load registers from memory.

It is similar to the register indirect mode, but the 16-bit general register specified in the register field of the instruction is incremented after the operand is accessed. The size of the increment is 1 or 2 depending on the size of the operand: 1 for MOV.B; 2 for MOV.W. For MOV.W, the original contents of the 16-bit general register must be even.

- **Register Indirect with Pre-Decrement—@-Rn**

The @-Rn mode is used with MOV instructions that store register contents to memory.

It is similar to the register indirect mode, but the 16-bit general register specified in the register field of the instruction is decremented before the operand is accessed. The size of the decrement is 1 or 2 depending on the size of the operand: 1 for MOV.B; 2 for MOV.W. For MOV.W, the original contents of the 16-bit general register must be even.

(5) Absolute Address—@aa:8 or @aa:16: The instruction specifies the absolute address of the operand in memory. The MOV.B instruction uses an 8-bit absolute address of the form H'FFxx. The upper 8 bits are assumed to be 1, so the possible address range is H'FF00 to H'FFFF (65280 to 65535). The MOV.B, MOV.W, JMP, and JSR instructions can use 16-bit absolute addresses.

(6) Immediate—#xx:8 or #xx:16: The instruction contains an 8-bit operand in its second byte, or a 16-bit operand in its third and fourth bytes. Only MOV.W instructions can contain 16-bit immediate values.

The ADDS and SUBS instructions implicitly contain the value 1 or 2 as immediate data. Some bit manipulation instructions contain 3-bit immediate data (#xx:3) in the second or fourth byte of the instruction, specifying a bit number.

(7) Program-Counter-Relative—@(d:8, PC): This mode is used to generate branch addresses in the B_{CC} and BSR instructions. An 8-bit value in byte 2 of the instruction code is added as a sign-extended value to the program counter contents. The result must be an even number. The possible branching range is -126 to +128 bytes (-63 to +64 words) from the current address.

(8) Memory Indirect—@@aa:8: This mode can be used by the JMP and JSR instructions. The second byte of the instruction code specifies an 8-bit absolute address from H'0000 to H'00FF (0 to 255). The word located at this address contains the branch address. The upper 8 bits of the absolute address are an "0" (H'00), thus the branch address is limited to values from 0 to 255 (H'0000 to H'00FF). Note that addresses H'0000 to H'0047 (0 to 71) are located in the vector table.

If an odd address is specified as a branch destination or as the operand address of a MOV.W instruction, the least significant bit is regarded as "0," causing word access to be performed at the address preceding the specified address. See section 2.4.2, "Memory Data Formats," for further information.

2.3.2 How to Calculate Where the Execution Starts

Table 2.2 shows how to calculate the Effective Address (EA: Effective Address) for each addressing mode.

In the operation instruction, 1) register direct, as well as 6) immediate (for each instruction, ADD.B, ADDX, SUBX, CMP.B, AND, OR, XOR) are used.

In the move instruction, 7) program counter relative and 8) all addressing mode to delete the memory indirect can be used.

In the bit manipulation instruction for the operand specifications, 1) register direct, 2) register indirect, as well as 5) absolute address (8 bit) can be used. Furthermore, to specify the bit number within the operand, 1) register direct (for each instruction, BSET, BCLR, BNOT, BTST) as well as 6) immediate (3 bit) can be used independently.

Table 2.2 Effective Address Calculation

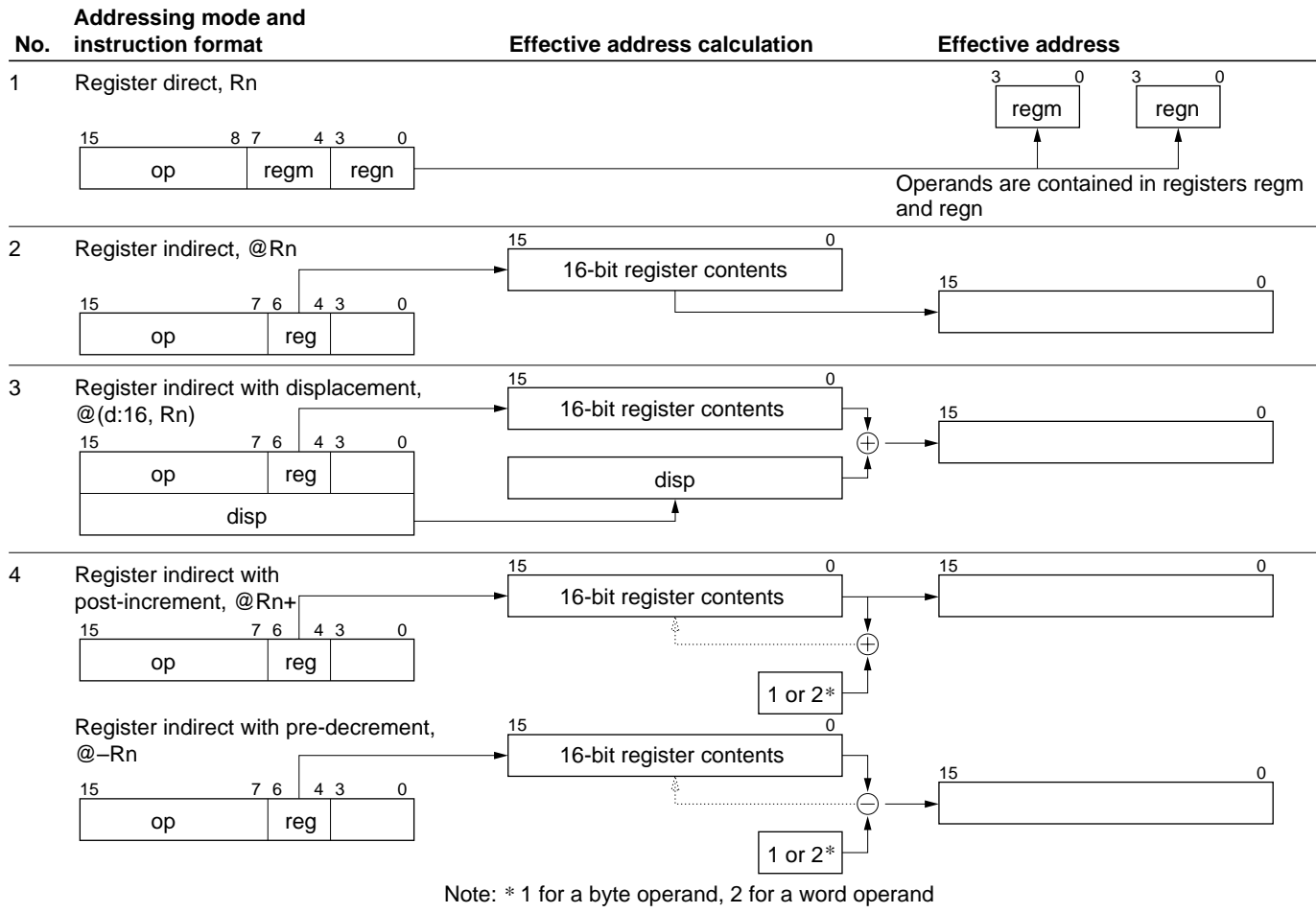

Table 2.2 Effective Address Calculation (cont)



No.	Addressing mode and instruction format	Effective address calculation	Effective address
5	<p>Absolute address</p> <p>@aa:8</p>  <p>@aa:16</p> 	 	 
6	<p>Immediate</p> <p>#xx:8</p>  <p>#xx:16</p> 	<p>Operand is 1- or 2-byte immediate data</p>	
7	<p>PC-relative</p> <p>@(d:8, PC)</p> 		

Table 3-2. Effective Address Calculation (3)

No.	Addressing mode and instruction format	Effective address calculation	Effective address
8	Memory indirect, @@aa:8		

Notation

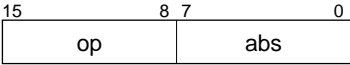
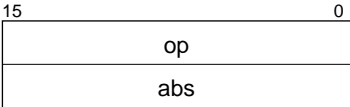
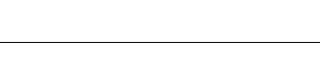
- reg: General register
- op: Operation code
- disp: Displacement
- IMM: Immediate data
- abs: Absolute address

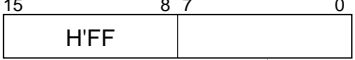
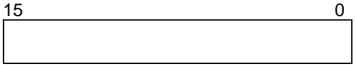
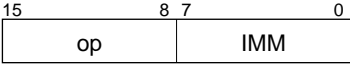
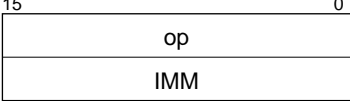
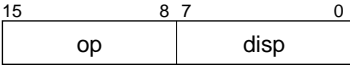
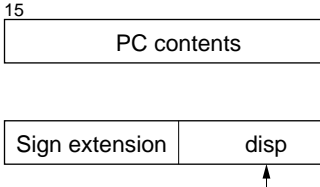
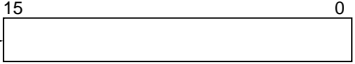
2.4 Data Formats

The H8/300 CPU can process 1-bit data, 4-bit (BCD) data, 8-bit (byte) data, and 16-bit (word) data.

- Bit manipulation instructions operate on 1-bit data specified as bit n ($n = 0, 1, 2, \dots, 7$) in a byte operand.
- All arithmetic and logic instructions except ADDS and SUBS can operate on byte data.
- The DAA and DAS instruction perform decimal arithmetic adjustments on byte data in packed BCD form. Each nibble of the byte is treated as a decimal digit.
- The MOV.W, ADD.W, SUB.W, CMP.W, ADDS, SUBS, MULXU ($8 \text{ bits} \times 8 \text{ bits}$), and DIVXU ($16 \text{ bits} \div 8 \text{ bits}$) instructions operate on word data.

2.4.1 Data Formats in General Registers

Data of all the sizes above can be stored in general registers as shown in figure 2.3.

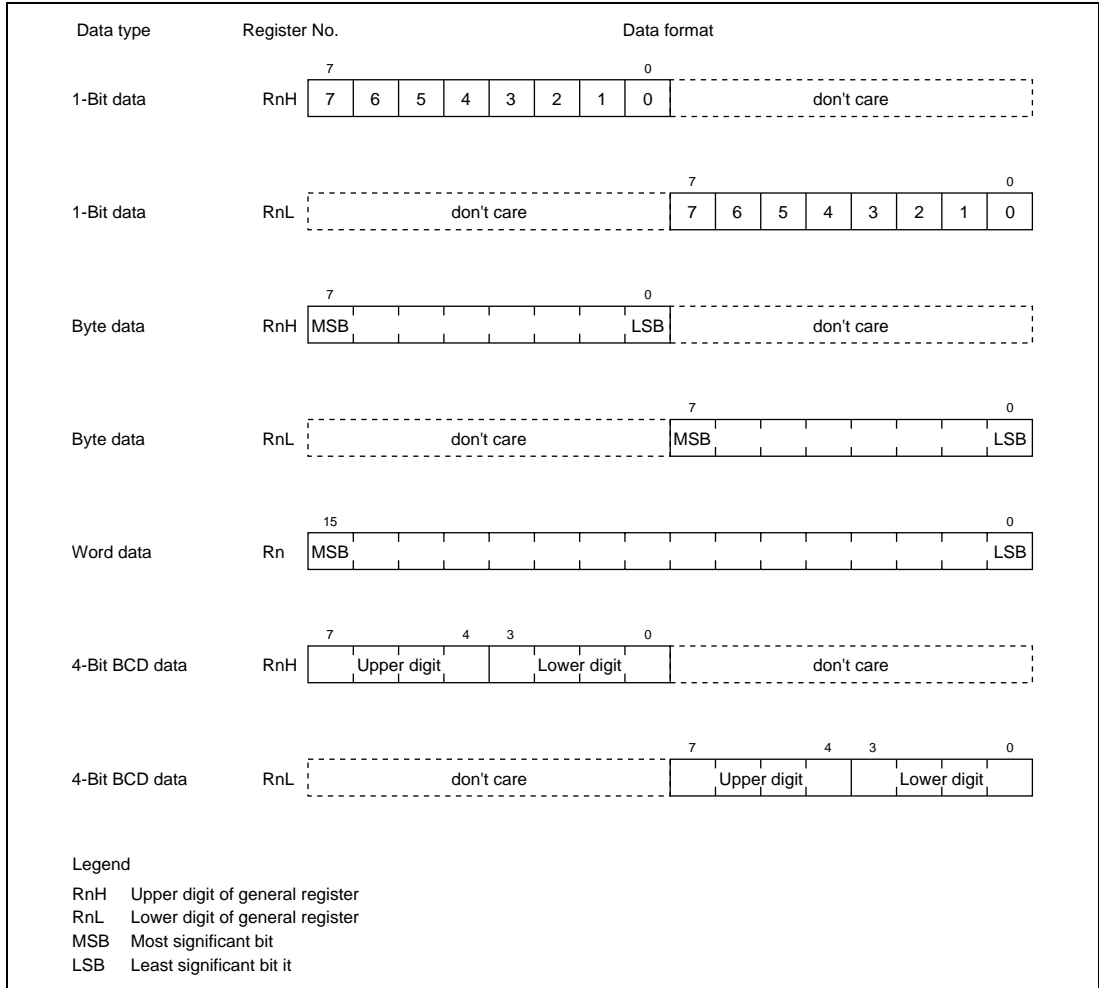

Figure 2.3 Register Data Formats

2.4.2 Memory Data Formats

Figure 2.4 indicates the data formats in memory.

Word data stored in memory must always begin at an even address. In word access the least significant bit of the address is regarded as “0.” If an odd address is specified, no address error occurs but the access is performed at the preceding even address. This rule affects MOV.W instructions and branching instructions, and implies that only even addresses should be stored in the vector table.

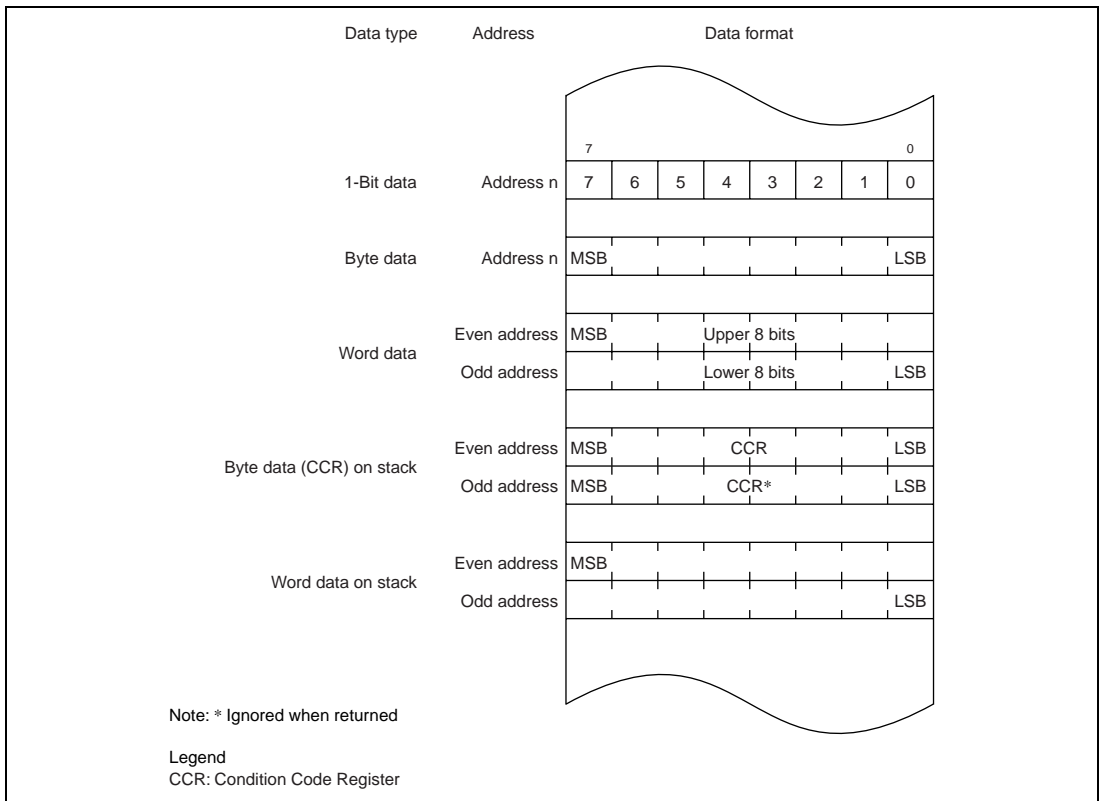

Figure 2.4 Memory Data Formats

When the stack is addressed by register R7, it must always be accessed a word at a time. When the CCR is pushed on the stack, two identical copies of the CCR are pushed to make a complete word. When they are returned, the lower byte is ignored.

2.5 Instruction Set

Table 2.3 lists the H8/300 instruction set.

Table 2.3 Instruction Classification

Function	Instructions	Types
Data transfer	MOV, MOVTP ^{*3} , MOVFPE ^{*3} , PUSH ^{*1} , POP ^{*1}	3
Arithmetic operations	ADD, SUB, ADDX, SUBX, INC, DEC, ADDS, SUBS, DAA, DAS, MULXU, DIVXU, CMP, NEG	14
Logic operations	AND, OR, XOR, NOT	4
Shift	SHAL, SHAR, SHLL, SHLR, ROTL, ROTR, ROTXL, ROTXR	8
Bit manipulation	BSET, BCLR, BNOT, BTST, BAND, BIAN, BOR, BIOR, BXOR, BIXOR, BLD, BILD, BST, BIST	14
Branch	Bcc ^{*2} , JMP, BSR, JSR, RTS	5
System control	RTE, SLEEP, LDC, STC, ANDC, ORC, XORC, NOP	8
Block data transfer	EEPMOV	1

Total 57

Notes: 1. PUSH Rn is equivalent to MOV.W Rn, @-SP.

POP Rn is equivalent to MOV.W @SP+, Rn.

2. Bcc is a conditional branch instruction in which cc represents a condition code.

3. Not supported by the H8/338 Series.

The following sections give a concise summary of the instructions in each category, and indicate the bit patterns of their object code. The notation used is defined next.

Operation Notation

Rd	General register (destination)
Rs	General register (source)
Rn	General register
(EAd)	Destination operand
(EAs)	Source operand
SP	Stack pointer
PC	Program counter
CCR	Condition code register
N	N (negative) flag of CCR
Z	Z (zero) flag of CCR
V	V (overflow) flag of CCR
C	C (carry) flag of CCR
#imm	Immediate data
#xx:3	3-Bit immediate data
#xx:8	8-Bit immediate data
#xx:16	16-Bit immediate data
disp	Displacement
+	Addition
-	Subtraction
×	Multiplication
÷	Division
^	AND logical
∨	OR logical
⊕	Exclusive OR logical
→	Move
¬	Not

2.5.1 Data Transfer Instructions

Table 2.4 describes the data transfer instructions. Figure 2.5 shows their object code formats.

Table 2.4 Data Transfer Instructions

Instruction	Size*	Function
MOV	B/W	(EAs) → Rd, Rs → (EAd) Moves data between two general registers or between a general register and memory, or moves immediate data to a general register. The Rn, @Rn, @(d:16, Rn), @aa:16, #xx:8 or #xx:16, @-Rn, and @Rn+ addressing modes are available for byte or word data. The @aa:8 addressing mode is available for byte data only. The @-R7 and @R7+ modes require word operands. Do not specify byte size for these two modes.
MOVTPE	B	Not supported by the H8/338 Series.
MOVFPPE	B	Not supported by the H8/338 Series.
PUSH	W	Rn → @-SP Pushes a 16-bit general register onto the stack. Equivalent to MOV.W Rn, @-SP.
POP	W	@SP+ → Rn Pops a 16-bit general register from the stack. Equivalent to MOV.W @SP+, Rn.

Note: Size: operand size

B: Byte

W: Word

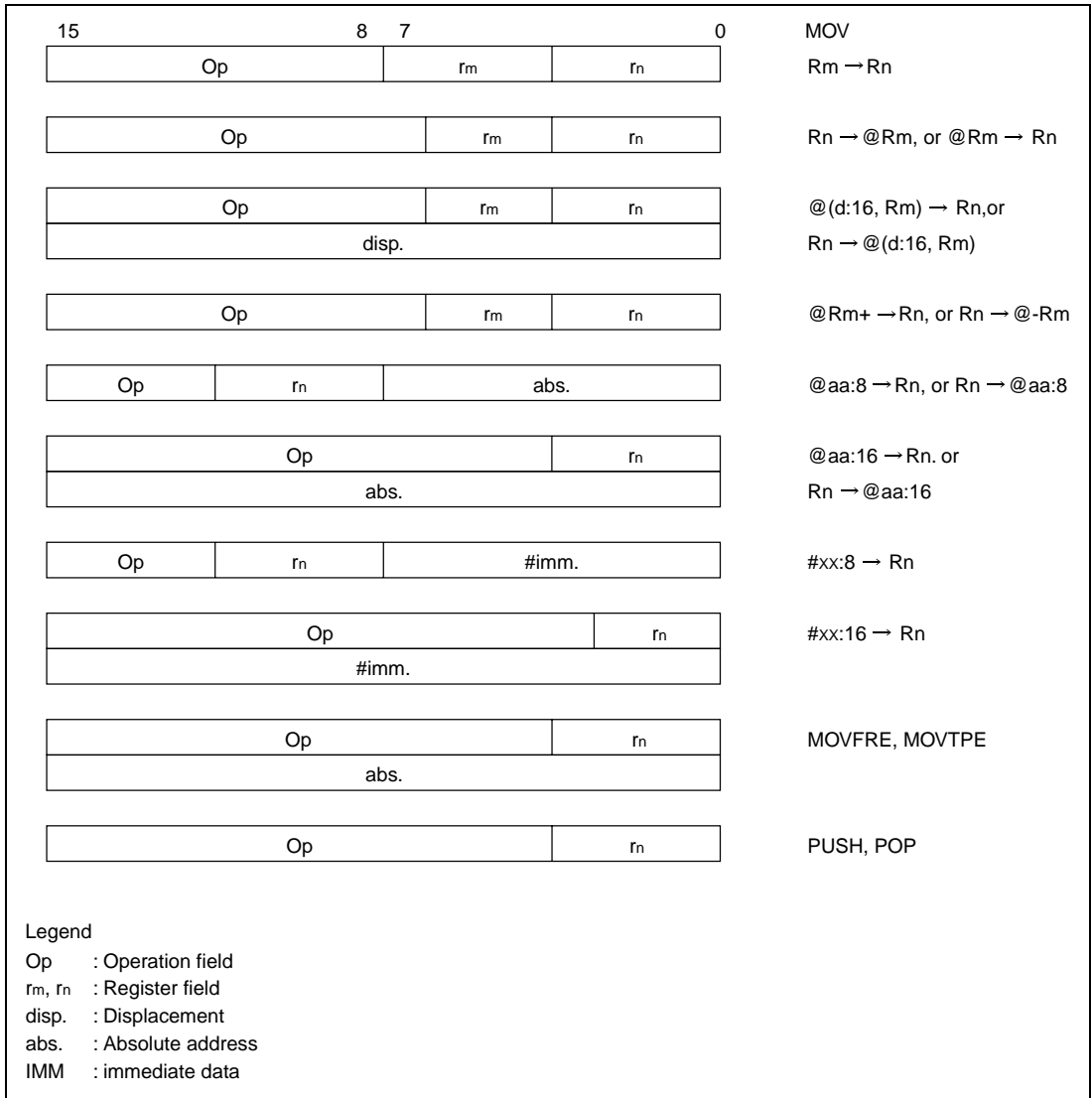

Figure 2.5 Data Transfer Instruction Codes

2.5.2 Arithmetic Operations

Table 2.5 describes the arithmetic instructions. See figure 2.6 in section 2.5.4, “Shift Operations” for their object codes.

Table 2.5 Arithmetic Instructions

Instruction	Size*	Function
ADD SUB	B/W	$Rd \pm Rs \rightarrow Rd$, $Rd + \#imm \rightarrow Rd$ Performs addition or subtraction on data in two general registers, or addition on immediate data and data in a general register. Immediate data cannot be subtracted from data in a general register. Word data can be added or subtracted only when both words are in general registers.
ADDX SUBX	B	$Rd \pm Rs \pm C \rightarrow Rd$, $Rd \pm \#imm \pm C \rightarrow Rd$ Performs addition or subtraction with carry or borrow on byte data in two general registers, or addition or subtraction on immediate data and data in a general register.
INC DEC	B	$Rd \pm \#1 \rightarrow Rd$ Increments or decrements a general register.
ADDS SUBS	W	$Rd \pm \#imm \rightarrow Rd$ Adds or subtracts immediate data to or from data in a general register. The immediate data must be 1 or 2.
DAA DAS	B	$Rd \text{ decimal adjust} \rightarrow Rd$ Decimal-adjusts (adjusts to packed BCD) an addition or subtraction result in a general register by referring to the CCR.
MULXU	B	$Rd \times Rs \rightarrow Rd$ Performs 8-bit \times 8-bit unsigned multiplication on data in two general registers, providing a 16-bit result.
DIVXU	B	$Rd \div Rs \rightarrow Rd$ Performs 16-bit \div 8-bit unsigned division on data in two general registers, providing an 8-bit quotient and 8-bit remainder.
CMP	B/W	$Rd - Rs$, $Rd - \#imm$ Compares data in a general register with data in another general register or with immediate data. Word data can be compared only between two general registers.
NEG	B	$0 - Rd \rightarrow Rd$ Obtains the two's complement (arithmetic complement) of data in a general register.

Note: Size: operand size

B: Byte

W: Word

2.5.3 Logic Operations

Table 2.6 describes the four instructions that perform logic operations. See figure 2.6 in section 2.5.4, “Shift Operations,” for their object codes.

Table 2.6 Logic Operation Instructions

Instruction	Size*	Function
AND	B	$Rd \wedge Rs \rightarrow Rd$, $Rd \wedge \#imm \rightarrow Rd$ Performs a logical AND operation on a general register and another general register or immediate data.
OR	B	$Rd \vee Rs \rightarrow Rd$, $Rd \vee \#imm \rightarrow Rd$ Performs a logical OR operation on a general register and another general register or immediate data.
XOR	B	$Rd \oplus Rs \rightarrow Rd$, $Rd \oplus \#imm \rightarrow Rd$ Performs a logical exclusive OR operation on a general register and another general register or immediate data.
NOT	B	$\neg (Rd) \rightarrow (Rd)$ Obtains the one’s complement (logical complement) of general register contents.

Note: Size: operand size
B: Byte

2.5.4 Shift Operations

Table 2.7 describes the eight shift instructions. Figure 2.6 shows the object code formats of the arithmetic, logic, and shift instructions.

Table 2.7 Shift Instructions

Instruction	Size*	Function
SHAL SHAR	B	$Rd \text{ shift} \rightarrow Rd$ Performs an arithmetic shift operation on general register contents.
SHLL SHLR	B	$Rd \text{ shift} \rightarrow Rd$ Performs a logical shift operation on general register contents.
ROTL ROTR	B	$Rd \text{ rotate} \rightarrow Rd$ Rotates general register contents.
ROTXL ROTXR	B	$Rd \text{ rotate through carry} \rightarrow Rd$ Rotates general register contents through the C (carry) bit.

Note: Size: operand size
B: Byte

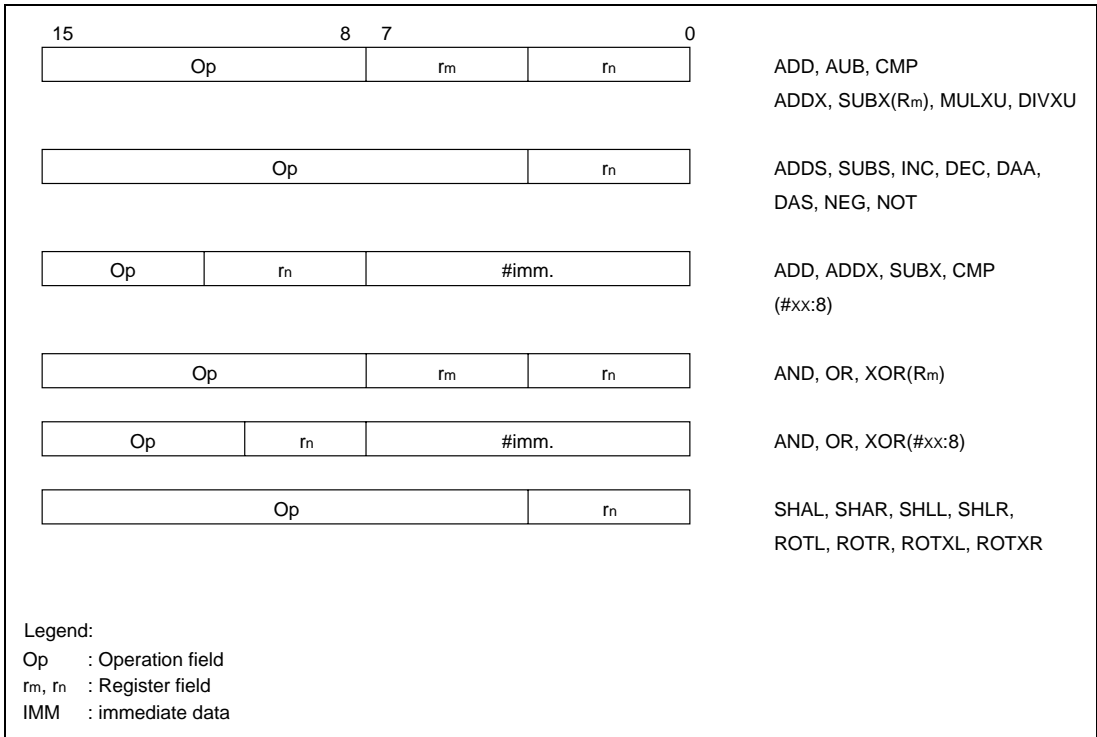

Figure 2.6 Arithmetic, Logic, and Shift Instruction Codes

2.5.5 Bit Manipulations

Table 2.8 describes the bit-manipulation instructions. Figure 2.7 shows their object code formats.

Table 2.8 Bit-Manipulation Instructions

Instruction	Size*	Function
BSET	B	$1 \rightarrow (\text{<bit-No.> of <EAd>})$ Sets a specified bit in a general register or memory to “1.” The bit is specified by a bit number, given in 3-bit immediate data or the lower three bits of a general register.
BCLR	B	$0 \rightarrow (\text{<bit-No.> of <EAd>})$ Clears a specified bit in a general register or memory to “0.” The bit is specified by a bit number, given in 3-bit immediate data or the lower three bits of a general register.
BNOT	B	$\neg (\text{<bit-No.> of <EAd>}) \rightarrow (\text{<bit-No.> of <EAd>})$ Inverts a specified bit in a general register or memory. The bit is specified by a bit number, given in 3-bit immediate data or the lower three bits of a general register.
BTST	B	$\neg (\text{<bit-No.> of <EAd>}) \rightarrow Z$ Tests a specified bit in a general register or memory and sets or clears the Z flag accordingly. The bit is specified by a bit number, given in 3-bit immediate data or the lower three bits of a general register.
BAND	B	$C \wedge (\text{<bit-No.> of <EAd>}) \rightarrow C$ ANDs the C flag with a specified bit in a general register or memory.
BIAND		$C \wedge [\neg (\text{<bit-No.> of <EAd>})] \rightarrow C$ ANDs the C flag with the inverse of a specified bit in a general register or memory. The bit number is specified by 3-bit immediate data.
BOR	B	$C \vee (\text{<bit-No.> of <EAd>}) \rightarrow C$ ORs the C flag with a specified bit in a general register or memory.
BIOR		$C \vee [\neg (\text{<bit-No.> of <EAd>})] \rightarrow C$ ORs the C flag with the inverse of a specified bit in a general register or memory. The bit number is specified by 3-bit immediate data.
BXOR	B	$C \oplus (\text{<bit-No.> of <EAd>}) \rightarrow C$ XORs the C flag with a specified bit in a general register or memory.

Note: Size: operand size

B: Byte

Table 2.8 Bit-Manipulation Instructions (cont)

Instruction	Size*	Function
BIXOR	B	$C \oplus \neg [(\text{<bit-No.> of <EAd>}] \rightarrow C$ XORs the C flag with the inverse of a specified bit in a general register or memory. The bit number is specified by 3-bit immediate data.
BLD	B	$(\text{<bit-No.> of <EAd>} \rightarrow C$ Copies a specified bit in a general register or memory to the C flag.
BILD		$\neg (\text{<bit-No.> of <EAd>} \rightarrow C$ Copies the inverse of a specified bit in a general register or memory to the C flag. The bit number is specified by 3-bit immediate data.
BST	B	$C \rightarrow (\text{<bit-No.> of <EAd>})$ Copies the C flag to a specified bit in a general register or memory.
BIST		$\neg C \rightarrow (\text{<bit-No.> of <EAd>})$ Copies the inverse of the C flag to a specified bit in a general register or memory. The bit number is specified by 3-bit immediate data.

Note: Size: operand size

B: Byte

Notes on Bit Manipulation Instructions: BSET, BCLR, BNOT, BST, and BIST are read-modify-write instructions. They read a byte of data, modify one bit in the byte, then write the byte back. Care is required when these instructions are applied to registers with write-only bits and to the I/O port registers.

Step		Description
1	Read	Read one data byte at the specified address
2	Modify	Modify one bit in the data byte
3	Write	Write the modified data byte back to the specified address

Example 1: BCLR is executed to clear bit 0 in the port 4 data direction register (P4DDR) under the following conditions.

P4₇: Input pin, Low

P4₆: Input pin, High

P4₅ – P4₀: Output pins, Low

The intended purpose of this BCLR instruction is to switch P4₀ from output to input.

Before Execution of BCLR Instruction

	P4 ₇	P4 ₆	P4 ₅	P4 ₄	P4 ₃	P4 ₂	P4 ₁	P4 ₀
Input/output	Input	Input	Output	Output	Output	Output	Output	Output
Pin state	Low	High	Low	Low	Low	Low	Low	Low
DDR	0	0	1	1	1	1	1	1
DR	1	0	0	0	0	0	0	0

Execution of BCLR Instruction

```
BCLR #0, @P4DDR ; clear bit 0 in data direction register
```

After Execution of BCLR Instruction

	P4 ₇	P4 ₆	P4 ₅	P4 ₄	P4 ₃	P4 ₂	P4 ₁	P4 ₀
Input/output	Output	Output	Output	Output	Output	Output	Output	Input
Pin state	Low	High	Low	Low	Low	Low	Low	High
DDR	1	1	1	1	1	1	1	0
DR	1	0	0	0	0	0	0	0

Explanation: To execute the BCLR instruction, the CPU begins by reading P4DDR. Since P4DDR is a write-only register, it is read as H'FF, even though its true value is H'3F.

Next the CPU clears bit 0 of the read data, changing the value to H'FE.

Finally, the CPU writes this value (H'FE) back to P4DDR to complete the BCLR instruction.

As a result, P4₀DDR is cleared to "0," making P4₀ an input pin. In addition, P4₇DDR and P4₆DDR are set to "1," making P4₇ and P4₆ output pins.

15	8	7	0	
Op		#imm.	rn	BSET, BCLR, BNOT, BTST Operand: register direct (Rn) Bit No.: immediate (#xx:3)
Op		rm	rn	Operand: register direct (Rn) Bit No.: register direct (Rm)
Op		rn	0 0 0 0	Operand: register indirect (@Rn) Bit No.: immediate (#xx:3)
Op		#imm.	0 0 0 0	
Op		rn	0 0 0 0	Operand: register indirect (@Rn) Bit No.: register direct (Rm)
Op		rm	0 0 0 0	
Op		abs.		Operand: absolute (@aa:8) Bit No.: immediate (#xx:3)
Op		#imm.	0 0 0 0	
Op		abs.		Operand: absolute (@aa:8) Bit No.: register direct (Rm)
Op		rm	0 0 0 0	
Op		#imm.	rn	BAND, BOR, BXOR, BLD, BST Operand: register direct (Rn) Bit No.: immediate (#xx:3)
Op		rn	0 0 0 0	Operand: register indirect (@Rn) Bit No.: immediate (#xx:3)
Op		#imm.	0 0 0 0	
Op		abs.		Operand: absolute (@aa:8) Bit No.: immediate (#xx:3)
Op		#imm.	0 0 0 0	
Op		#imm.	rn	BIAND, BIOR, BIXOR, BILD, BIST Operand: register direct (Rn) Bit No.: immediate (#xx:3)
Op		rn	0 0 0 0	Operand: register indirect (@Rn) Bit No.: immediate (#xx:3)
Op		#imm.	0 0 0 0	
Op		abs.		Operand: absolute (@aa:8) Bit No.: immediate (#xx:3)
Op		#imm.	0 0 0 0	

Legend:
Op : Operation field
rm, rn : Register field
abs. : Absolute address
IMM : immediate data

Figure 2.7 Bit Manipulation Instruction Codes

2.5.6 Branching Instructions

Table 2.9 describes the branching instructions. Figure 2.8 shows their object code formats.

Table 2.9 Branching Instructions

Instruction	Size	Function			
Bcc	—	Branches if condition cc is true.			
		Mnemonic	cc field	Description	Condition
		BRA (BT)	0 0 0 0	Always (True)	Always
		BRN (BF)	0 0 0 1	Never (False)	Never
		BHI	0 0 1 0	High	$C \vee Z = 0$
		BLS	0 0 1 1	Low or Same	$C \vee Z = 1$
		BCC (BHS)	0 1 0 0	Carry Clear (High or Same)	$C = 0$
		BCS (BLO)	0 1 0 1	Carry Set (Low)	$C = 1$
		BNE	0 1 1 0	Not Equal	$Z = 0$
		BEQ	0 1 1 1	Equal	$Z = 1$
		BVC	1 0 0 0	Overflow Clear	$V = 0$
		BVS	1 0 0 1	Overflow Set	$V = 1$
		BPL	1 0 1 0	Plus	$N = 0$
		BMI	1 0 1 1	Minus	$N = 1$
		BGE	1 1 0 0	Greater or Equal	$N \oplus V = 0$
		BLT	1 1 0 1	Less Than	$N \oplus V = 1$
BGT	1 1 1 0	Greater Than	$Z \vee (N \oplus V) = 0$		
BLE	1 1 1 1	Less or Equal	$Z \vee (N \oplus V) = 1$		
JMP	—	Branches unconditionally to a specified address.			
JSR	—	Branches to a subroutine at a specified address.			
BSR	—	Branches to a subroutine at a specified displacement from the current address.			
RTS	—	Returns from a subroutine			

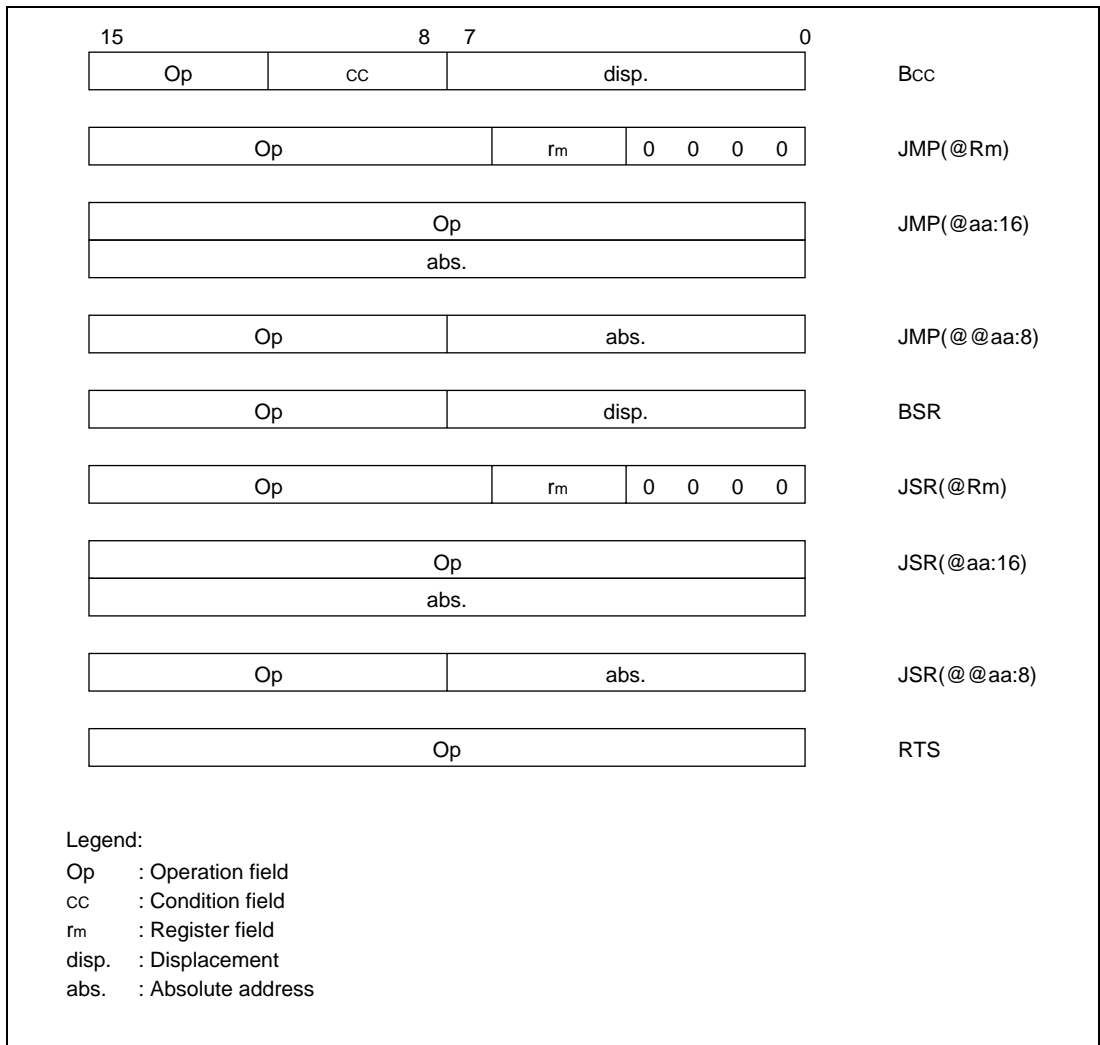

Figure 2.8 Branching Instruction Codes

2.5.7 System Control Instructions

Table 2.10 describes the system control instructions. Figure 2.9 shows their object code formats.

Table 2.10 System Control Instructions

Instruction	Size	Function
RTE	—	Returns from an exception-handling routine.
SLEEP	—	Causes a transition to the power-down state.
LDC	B	$R_s \rightarrow CCR$, $\#imm \rightarrow CCR$ Moves immediate data or general register contents to the condition code register.
STC	B	$CCR \rightarrow R_d$ Copies the condition code register to a specified general register.
ANDC	B	$CCR \wedge \#imm \rightarrow CCR$ Logically ANDs the condition code register with immediate data.
ORC	B	$CCR \vee \#imm \rightarrow CCR$ Logically ORs the condition code register with immediate data.
XORC	B	$CCR \oplus \#imm \rightarrow CCR$ Logically exclusive-ORs the condition code register with immediate data.
NOP	—	$PC + 2 \rightarrow PC$ Only increments the program counter.

Note: Size: operand size

B: Byte

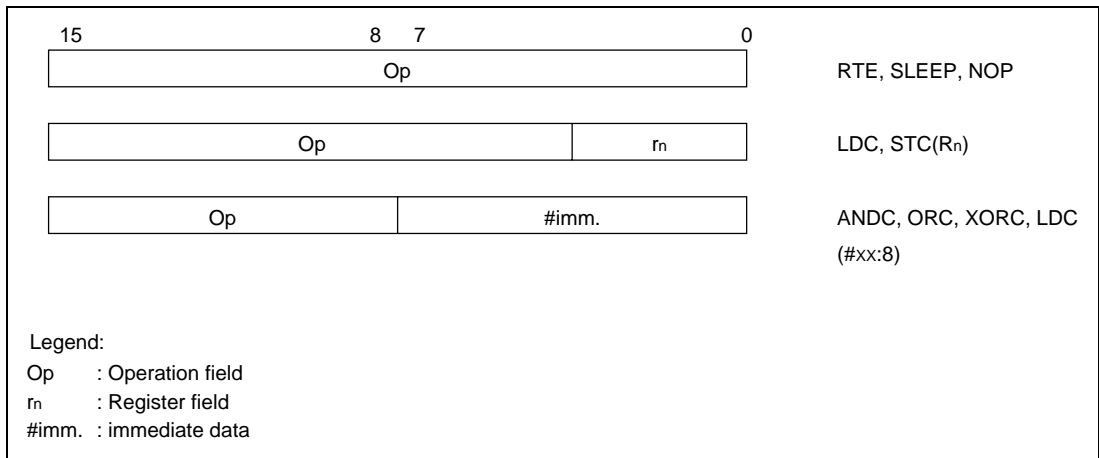

Figure 2.9 System Control Instruction Codes

2.5.8 Block Data Transfer Instruction

Table 2.11 describes the EEPMOV instruction. Figure 2.10 shows its object code format.

Table 2.11 Block Data Transfer Instruction/EEPROM Write Operation

Instruction	Size	Function
EEPMOV	—	if R4L ≠ 0 then repeat @R5+ → @R6+ R4L – 1 → R4L until R4L = 0 else next; Moves a data block according to parameters set in general registers R4L, R5, and R6. R4L: size of block (bytes) R5: starting source address R6: starting destination address Execution of the next instruction starts as soon as the block transfer is completed.

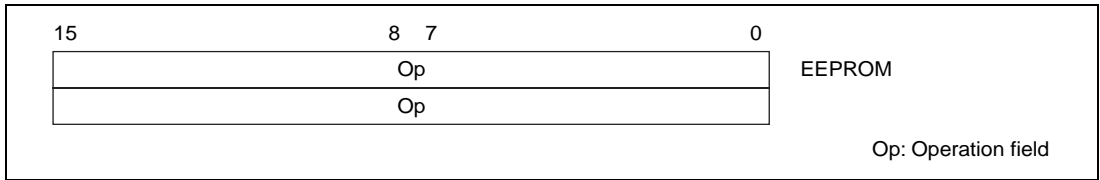
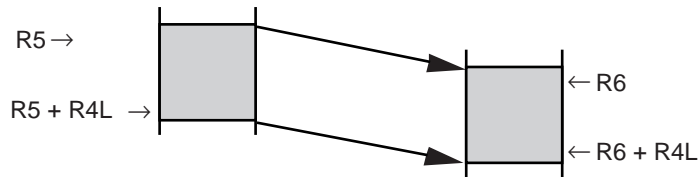

Figure 2.10 Block Data Transfer Instruction/EEPROM Write Operation Code

Notes on EEPMOV Instruction

Note 1

1. The EEPMOV instruction is a block data transfer instruction. It moves the number of bytes specified by R4L from the address specified by R5 to the address specified by R6.



2. When setting R4L and R6, make sure that the final destination address (R6 + R4L) does not exceed H'FFFF. The value in R6 must not change from H'FFFF to H'0000 during execution of the instruction.

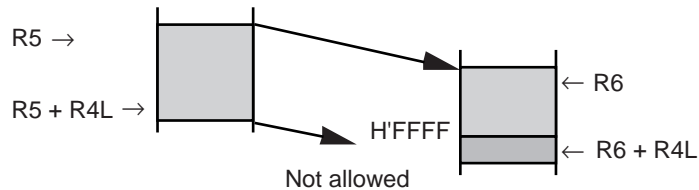

Note 2

CPU will malfunction after EEPMOV instruction execution, in the following conditions. EEPMOV instruction performs block data transfer function.

- Condition

When the following conditions are all true:

- The LSI is set to expanded mode (i.e. mode 1 or mode 2).
- The destination address of EEPMOV instruction is external area.
- At least one wait state is inserted to the last write bus cycle to the destination address by EEPMOV instruction.

2.6 CPU States

The CPU has three states: the program execution state, exception-handling state, and power-down state. The power-down state is further divided into three modes: the sleep mode, software standby mode, and hardware standby mode. Figure 2.11 summarizes these states, and figure 2.12 shows a map of the state transitions.

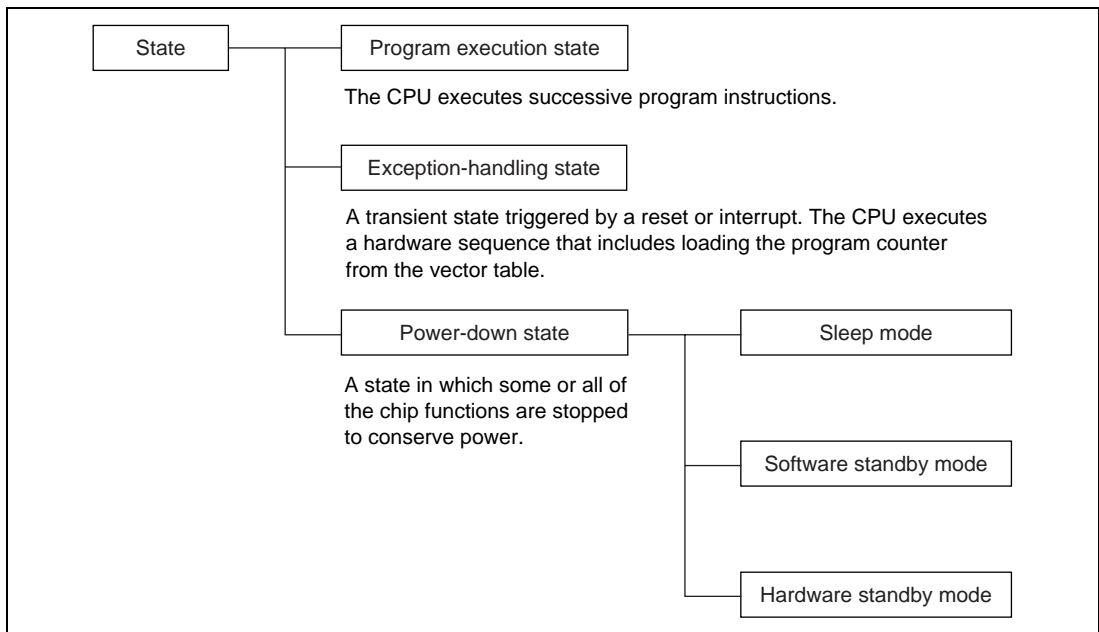

Figure 2.11 Operating States

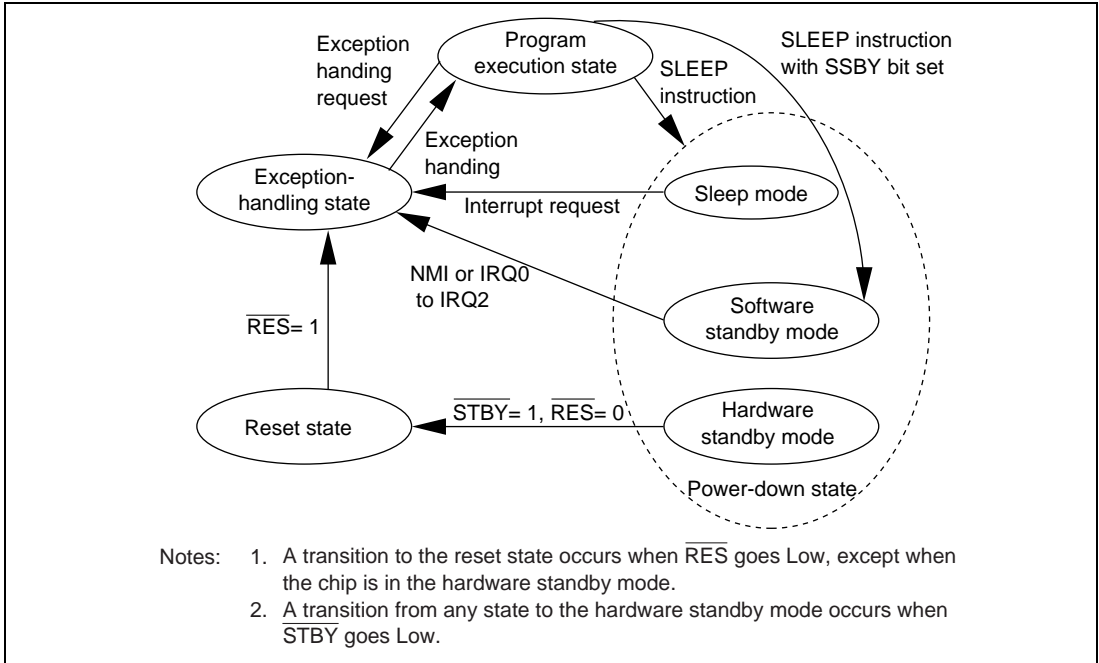

Figure 2.12 State Transitions

2.6.1 Program Execution State

In this state the CPU executes program instructions.

2.6.2 Exception-Handling State

The exception-handling state is a transient state that occurs when the CPU is reset or accepts an interrupt. In this state the CPU carries out a hardware-controlled sequence that prepares it to execute a user-coded exception-handling routine.

In the hardware exception-handling sequence the CPU does the following:

- (1) Saves the program counter and condition code register to the stack (except in the case of a reset).
- (2) Sets the interrupt mask (I) bit in the condition code register to “1.”
- (3) Fetches the start address of the exception-handling routine from the vector table.
- (4) Branches to that address, returning to the program execution state.

See section 4, “Exception Handling,” for further information on the exception-handling state.

2.6.3 Power-Down State

The power-down state includes three modes: the sleep mode, the software standby mode, and the hardware standby mode.

(1) Sleep Mode: The sleep mode is entered when a SLEEP instruction is executed. The CPU halts, but CPU register contents remain unchanged and the on-chip supporting modules continue to function.

(2) Software Standby Mode: The software standby mode is entered if the SLEEP instruction is executed while the SSBY (Software Standby) bit in the system control register (SYSCR) is set. The CPU and all on-chip supporting modules halt. The on-chip supporting modules are initialized, but the contents of the on-chip RAM and CPU registers remain unchanged. I/O port outputs also remain unchanged.

(3) Hardware Standby Mode: The hardware standby mode is entered when the input at the STBY pin goes Low. All chip functions halt, including I/O port output. The on-chip supporting modules are initialized, but on-chip RAM contents are held.

See section 14, "Power-Down State," for further information.

2.7 Access Timing and Bus Cycle

The CPU is driven by the system clock (ϕ). The period from one rising edge of the system clock to the next is referred to as a “state.”

Memory access is performed in a two- or three-state bus cycle. On-chip memory, on-chip supporting modules, and external devices are accessed in different bus cycles as described below.

2.7.1 Access to On-Chip Memory (RAM and ROM)

On-chip ROM and RAM are accessed in a cycle of two states designated T_1 and T_2 . Either byte or word data can be accessed, via a 16-bit data bus. Figure 2.13 shows the on-chip memory access cycle. Figure 2.14 shows the associated pin states.

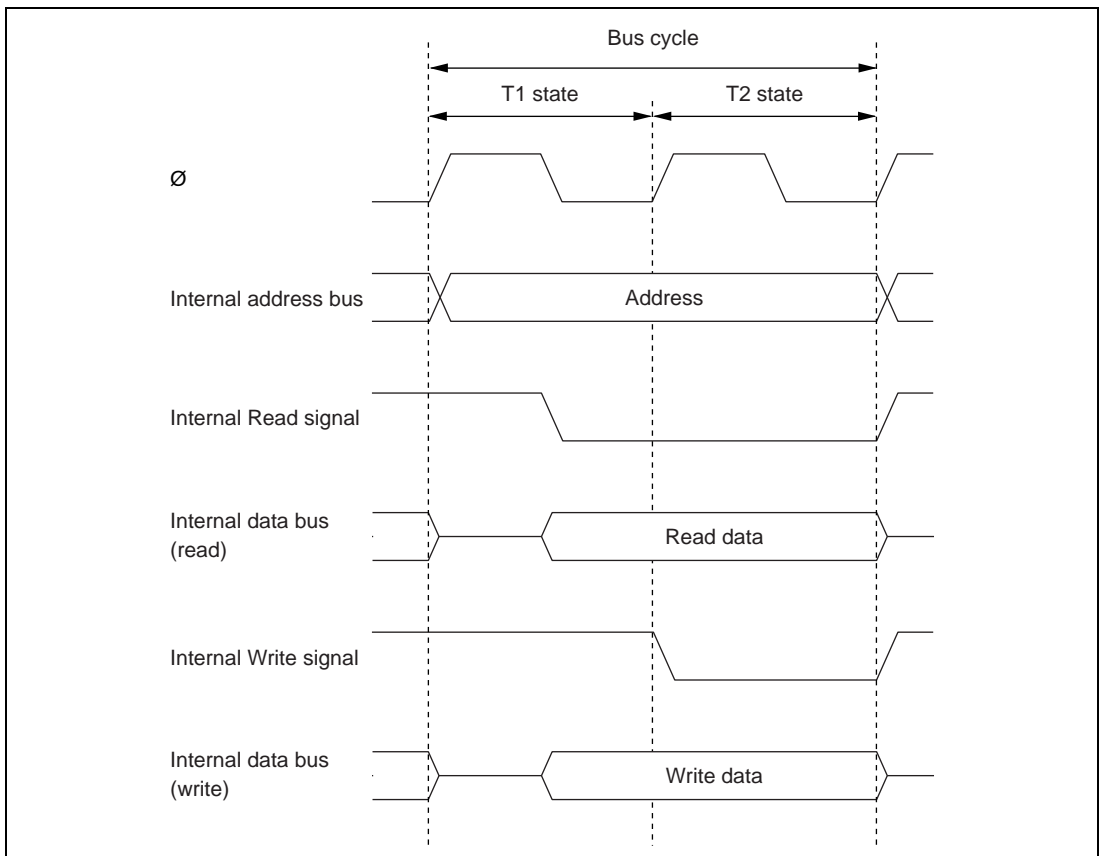

Figure 2.13 On-Chip Memory Access Cycle

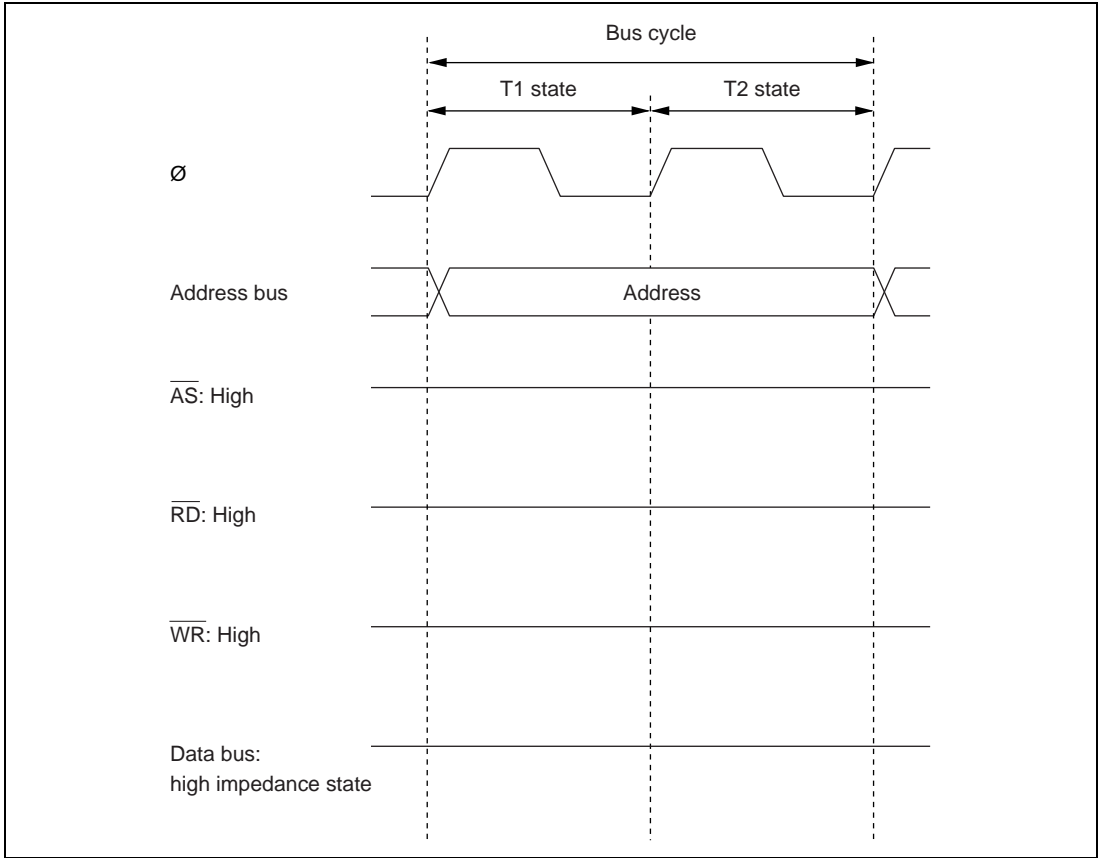

Figure 2.14 Pin States during On-Chip Memory Access Cycle

2.7.2 Access to On-Chip Register Field and External Devices

The on-chip register field (I/O ports, dual-port RAM, on-chip supporting module registers, etc.) and external devices are accessed in a cycle consisting of three states: T_1 , T_2 , and T_3 . Only one byte of data can be accessed per cycle, via an 8-bit data bus. Access to word data or instruction codes requires two consecutive cycles (six states).

Figure 2.15 shows the access cycle for the on-chip register field. Figure 2.16 shows the associated pin states. Figures 2.17 (a) and (b) show the read and write access timing for external devices.

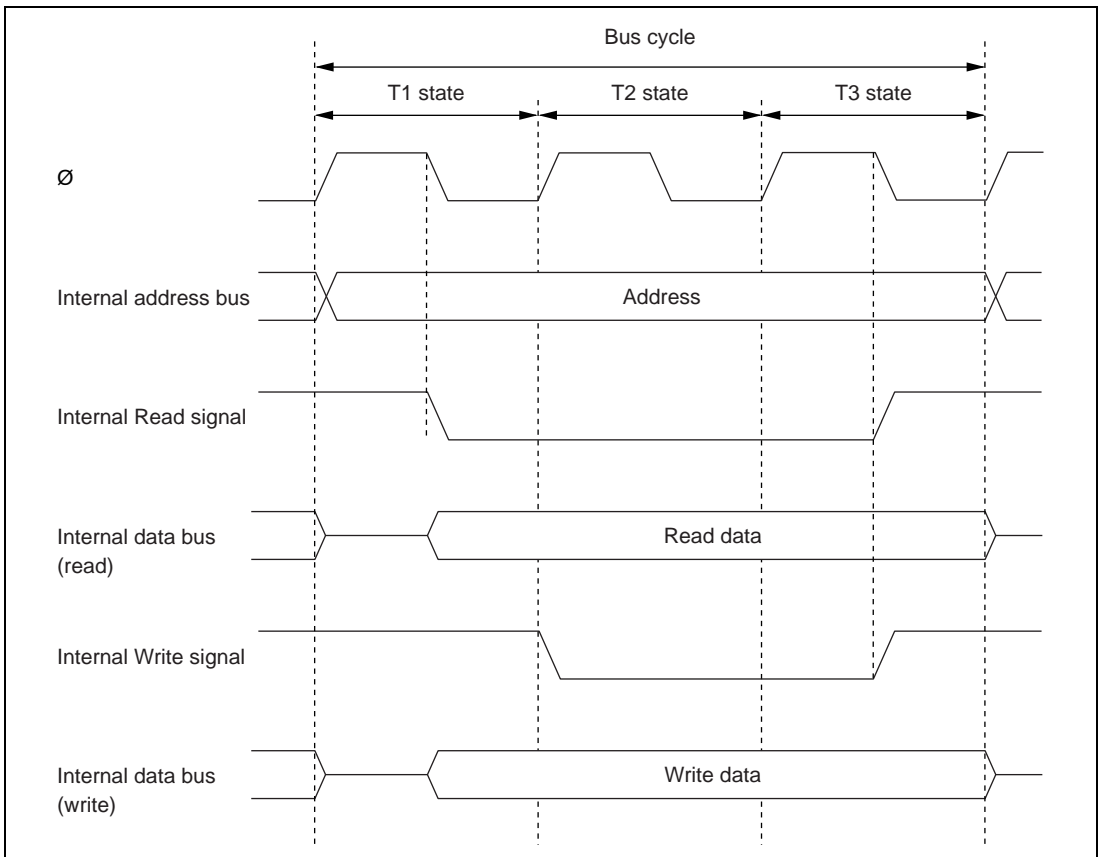

Figure 2.15 On-Chip Register Field Access Cycle

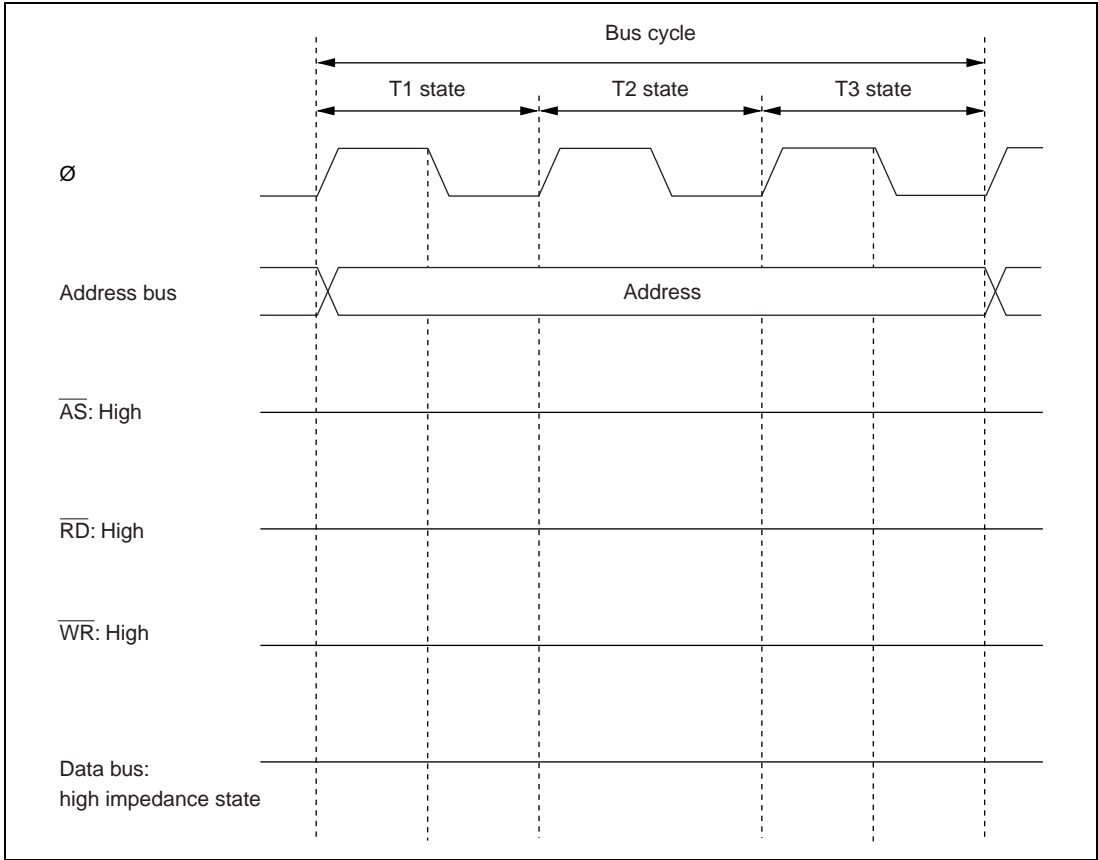

Figure 2.16 Pin States during On-Chip Register Field Access Cycle

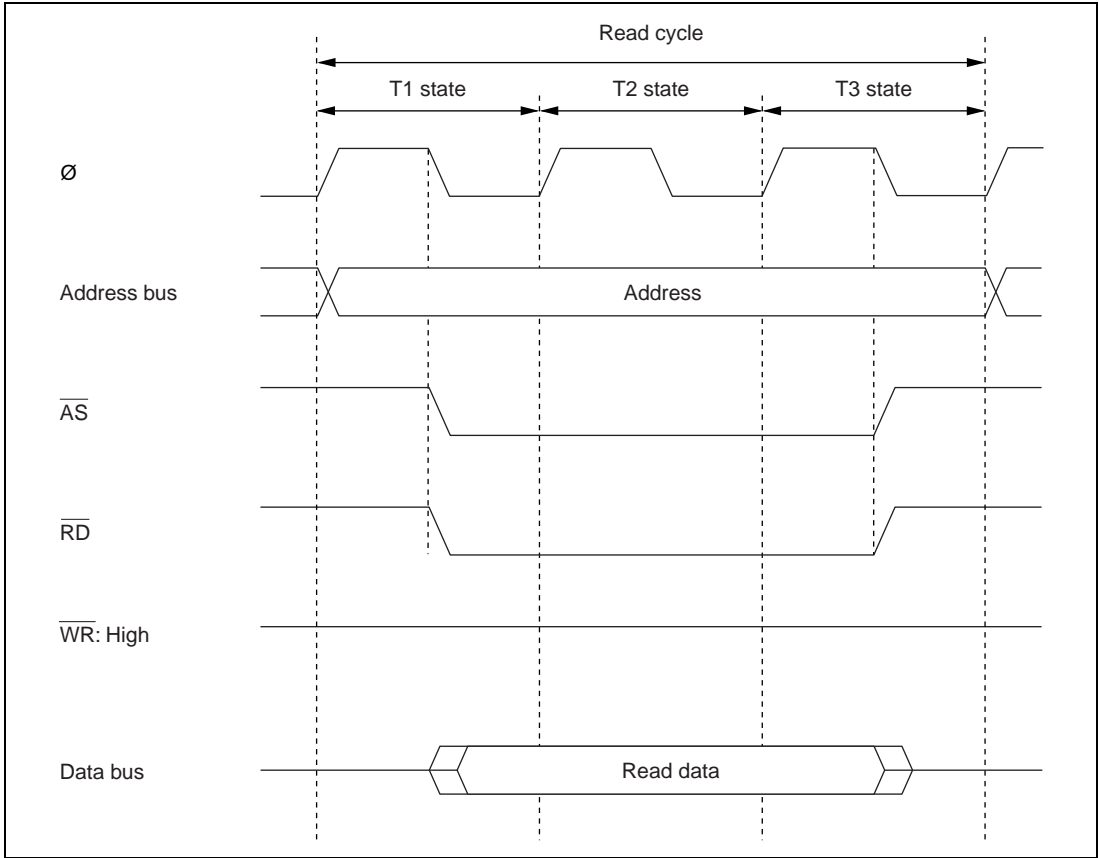

Figure 2.17 (a) External Device Access Timing (Read)

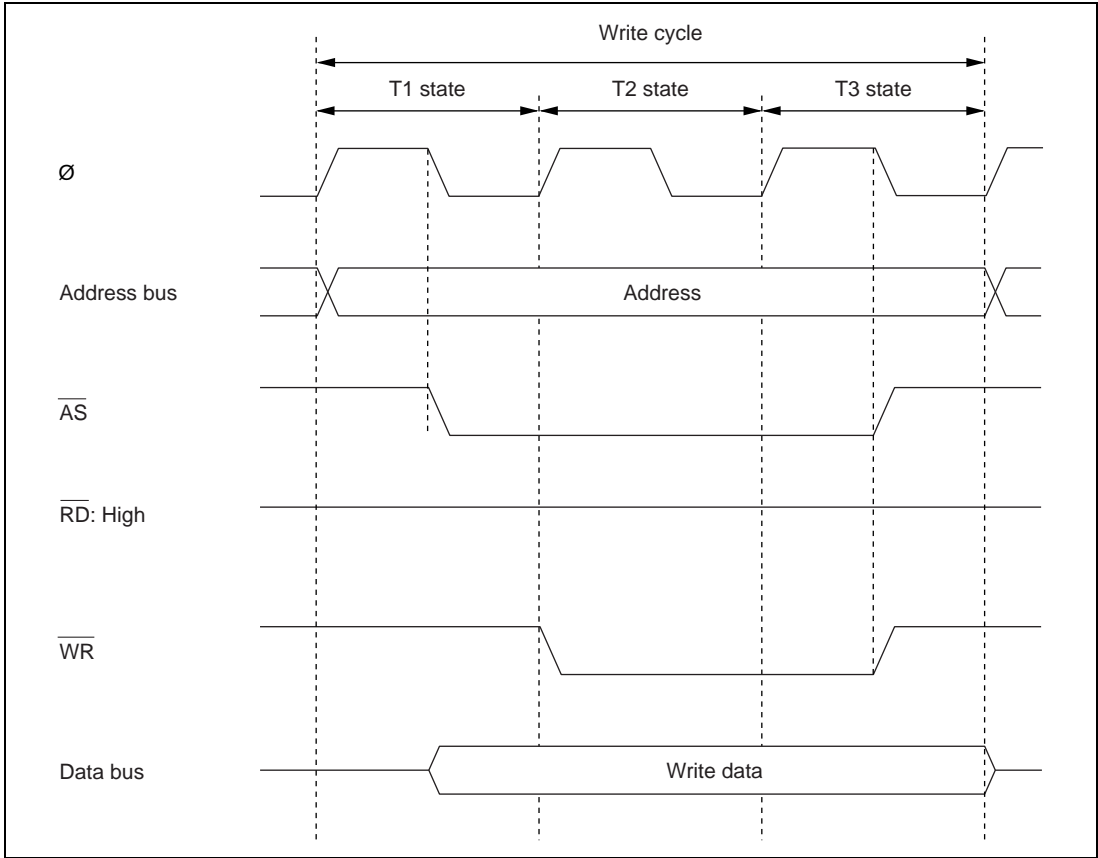

Figure 2.17 (b) External Device Access Timing (Write)

Section 3 MCU Operating Modes and Address Space

3.1 Overview

3.1.1 Mode Selection

The H8/338 Series operates in three modes numbered 1, 2, and 3. The mode is selected by the inputs at the mode pins (MD₁ and MD₀) when the chip comes out of a reset. See table 3.1.

The ROMless versions of the H8/338 Series (HD6413388, HD6413378) can be used only in mode 1 (expanded mode with on-chip ROM disabled).

Table 3.1 Operating Modes

Mode	MD1	MD0	Address space	On-chip ROM	On-chip RAM
Mode 0	Low	Low	—	—	—
Mode 1	Low	High	Expanded	Disabled	Enabled*
Mode 2	High	Low	Expanded	Enabled	Enabled*
Mode 3	High	High	Single-chip	Enabled	Enabled

Note: If the RAME bit in the system control register (SYSCR) is cleared to 0, off-chip memory can be accessed instead.

Modes 1 and 2 are expanded modes that permit access to off-chip memory and peripheral devices. The maximum address space supported by these externally expanded modes is 64K bytes.

In mode 3 (single-chip mode), only on-chip ROM and RAM and the on-chip register field are used. All ports are available for general-purpose input and output.

Mode 0 is inoperative in the H8/338 Series. Avoid setting the mode pins to mode 0.

In addition, the mode pins must not be changed during MCU operation.

3.1.2 Mode and System Control Registers (MDCR and SYSCR)

Table 3.2 lists the registers related to the chip’s operating mode: the system control register (SYSCR) and mode control register (MDCR). The mode control register indicates the inputs to the mode pins MD₁ and MD₀.

Table 3.2 Mode and System Control Registers

Name	Abbreviation	Read/Write	Address
System control register	SYSCR	R/W	H'FFC4
Mode control register	MDCR	R	H'FFC5

3.2 System Control Register (SYSCR)—H'FFC4

Bit:	7	6	5	4	3	2	1	0
	SSBY	STS2	STS1	STS0	—	NMIEG	DPME	RAME
Initial value:	0	0	0	0	1	0	0	1
Read/Write:	R/W	R/W	R/W	R/W	—	R/W	R/W*	R/W

Note: Do not write “1” in this bit.

The system control register (SYSCR) is an eight-bit register that controls the operation of the chip.

Bit 7—Software Standby (SSBY): Enables transition to the software standby mode. For details, see section 14, “Power-Down State.”

On recovery from software standby mode by an external interrupt, the SSBY bit remains set to “1.” It can be cleared by writing “0.”

Bit 7

SSBY	Description
0	The SLEEP instruction causes a transition to sleep mode. (Initial value)
1	The SLEEP instruction causes a transition to software standby mode.

Bits 6 to 4—Standby Timer Select 2 to 0 (STS2 to STS0): These bits select the clock settling time when the chip recovers from the software standby mode by an external interrupt. During the selected time the CPU and on-chip supporting modules continue to stand by. These bits should be set according to the clock frequency so that the settling time is at least 10ms. For specific settings, see section 14.2, “System Control Register: Power-Down Control Bits.”

Bit 6 STS2	Bit 5 STS1	Bit 4 STS0	Description
0	0	0	Settling time = 8192 states (Initial value)
0	0	1	Settling time = 16384 states
0	1	0	Settling time = 32768 states
0	1	1	Settling time = 65536 states
1	—	—	Settling time = 131072 states

Bit 3—Reserved: This bit cannot be modified and is always read as “1.”

Bit 2—NMI Edge (NMIEG): Selects the valid edge of the NMI input.

Bit 2 NMIEG	Description
0	An interrupt is requested on the falling edge of the $\overline{\text{NMI}}$ input. (Initial value)
1	An interrupt is requested on the rising edge of the $\overline{\text{NMI}}$ input.

Bit 1—Dual-Port RAM Mode Enable (DPME): Reserved. Do not write “1” in this bit.

Bit 0—RAM Enable (RAME): Enables or disables the on-chip RAM. The RAME bit is initialized by a reset, but is not initialized in the software standby mode.

Bit 0 RAME	Description
0	The on-chip RAM is disabled.
1	The on-chip RAM is enabled. (Initial value)

3.3 Mode Control Register (MDCR)—H'FFC5

Bit:	7	6	5	4	3	2	1	0
	—	—	—	—	—	—	MDS1	MDS0
Initial value:	1	1	1	0	0	1	*	*
Read/Write:	R	R	R	R	R	R	R	R

Note: Initialized according to MD₁ and MD₀ inputs.

The mode control register (MDCR) is an eight-bit register that indicates the operating mode of the chip.

Bits 7 to 5—Reserved: These bits cannot be modified and are always read as “1.”

Bits 4 and 3—Reserved: These bits cannot be modified and are always read as “0.”

Bit 2—Reserved: This bit cannot be modified and is always read as “1.”

Bits 1 and 0—Mode Select 1 and 0 (MDS1 and MDS0): These bits indicate the values of the mode pins (MD₁ and MD₀), thereby indicating the current operating mode of the chip. MDS1 corresponds to MD₁ and MDS0 to MD₀. These bits can be read but not written. When the mode control register is read, the levels at the mode pins (MD₁ and MD₀) are latched in these bits.

3.4 Address Space Map

Figures 3.1 to 3.3 show memory maps of the H8/338, H8/337, and H8/336 in modes 1, 2, and 3.

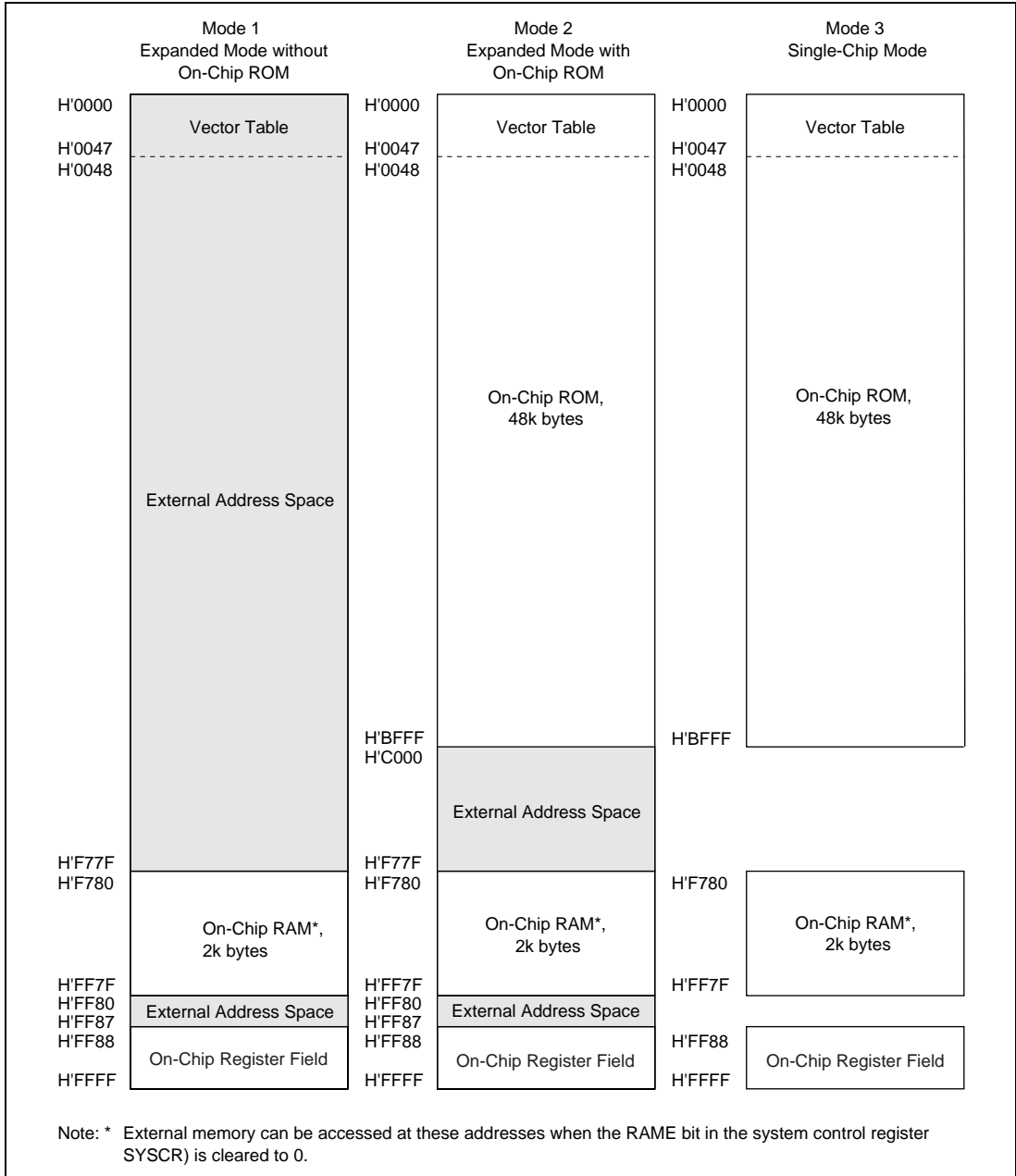

Figure 3.1 H8/338 Address Space Map

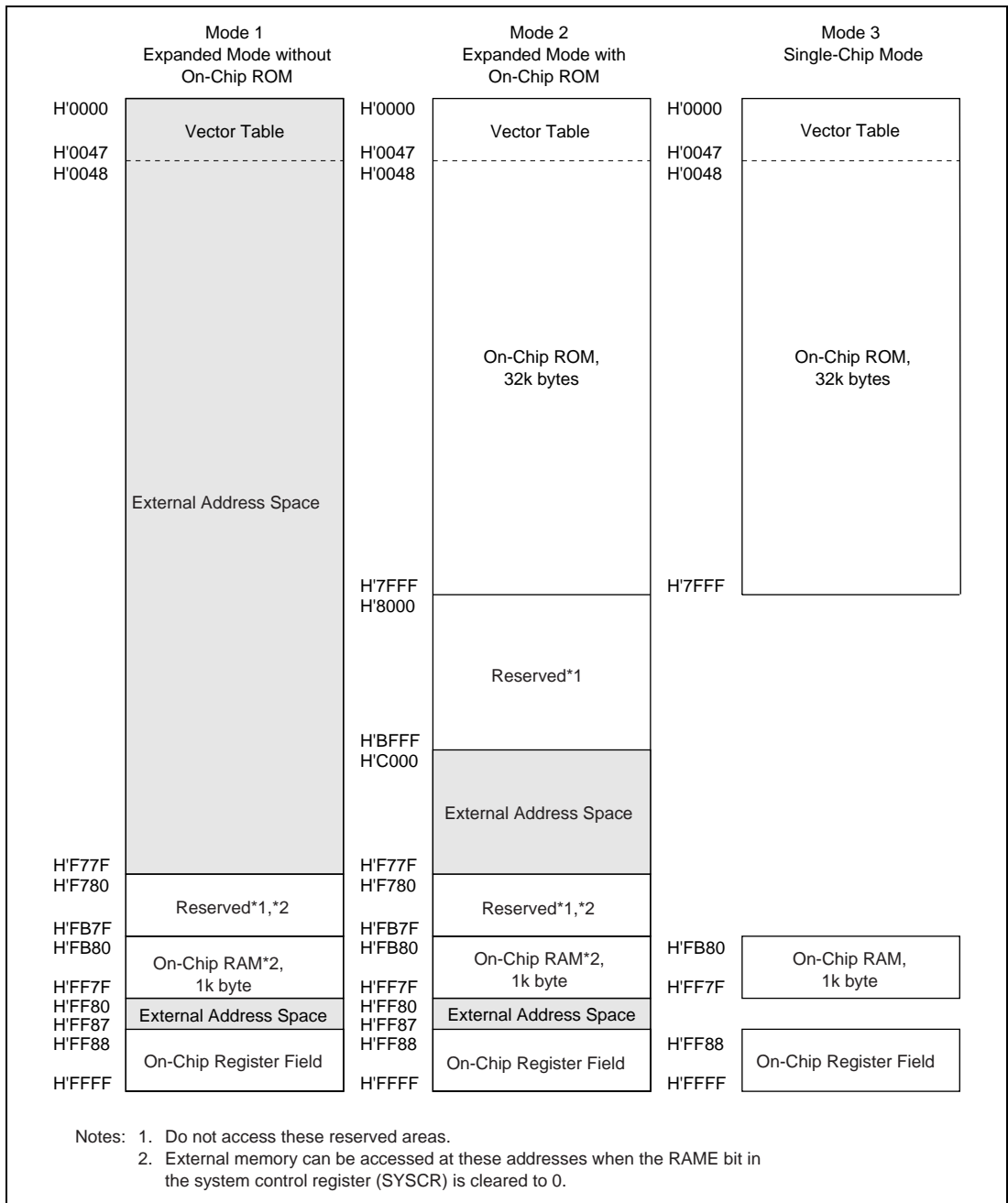

Figure 3.2 H8/337 Address Space Map

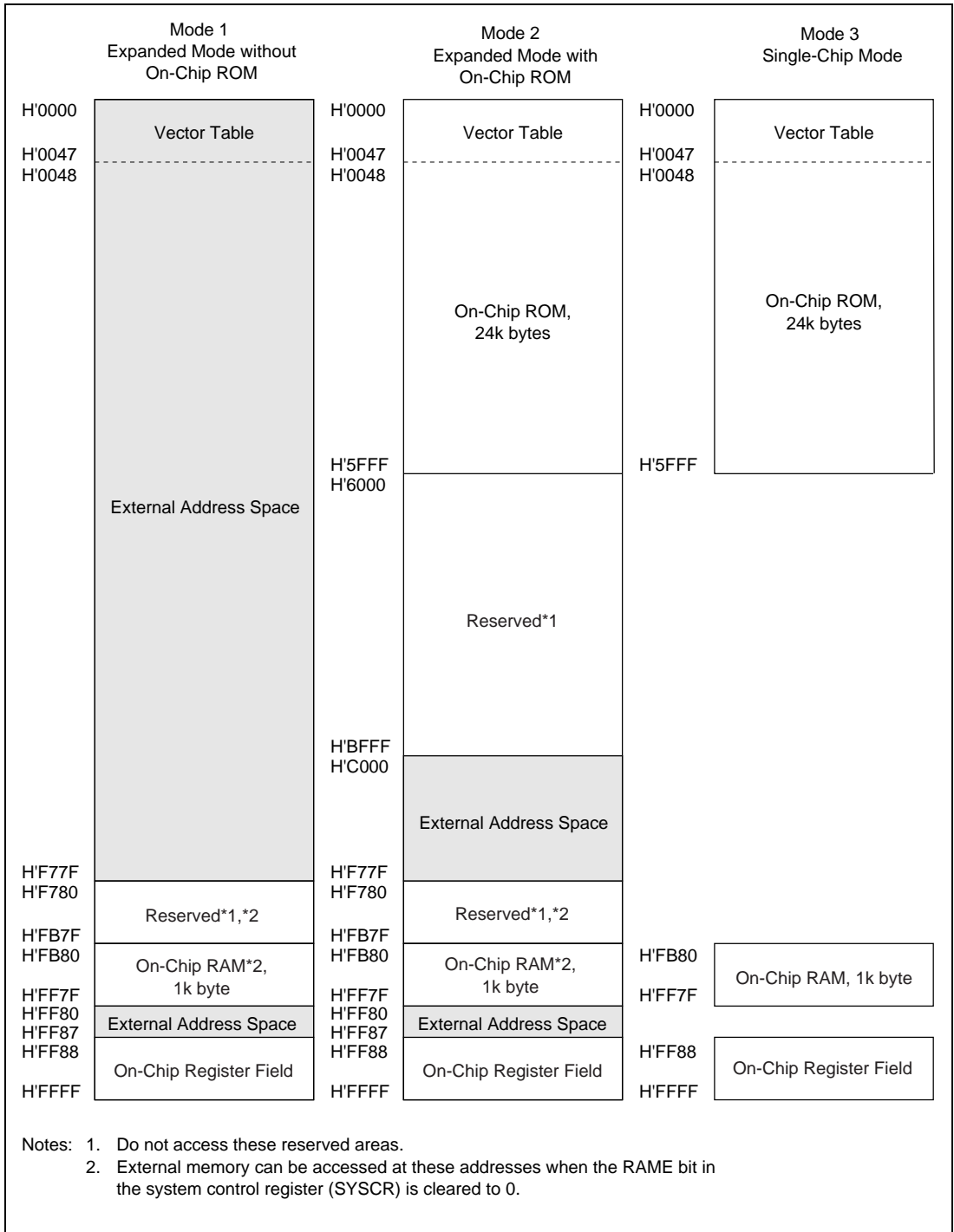

Figure 3.3 H8/336 Address Space Map

Section 4 Exception Handling

4.1 Overview

The H8/338 Series recognizes only two kinds of exceptions: interrupts and the reset. Table 4.1 indicates their priority and the timing of their hardware exception-handling sequence.

Table 4.1 Hardware Exception-Handling Sequences and Priority

Priority	Type of Exception	Timing of Exception-Handling Sequence
High	Reset	The hardware exception-handling sequence begins as soon as $\overline{\text{RES}}$ changes from Low to High.
Low	Interrupt	When an interrupt is requested, the hardware exception-handling sequence begins at the end of the current instruction, or at the end of the current hardware exception-handling sequence.

4.2 Reset

4.2.1 Overview

A reset has the highest exception-handling priority. When the RES pin goes Low, all current processing stops and the chip enters the reset state. The internal state of the CPU and the registers of the on-chip supporting modules are initialized. When RES returns from Low to High, the reset exception-handling sequence starts.

4.2.2 Reset Sequence

The reset state begins when RES goes Low. To ensure correct resetting, at power-on the RES pin should be held Low for at least 20ms. In a reset during operation, the RES pin should be held Low for at least 10 system clock cycles. For the pin states during a reset, see appendix C, “Pin States.”

When RES returns from Low to High, hardware carries out the following reset exception-handling sequence.

- (1) The internal state of the CPU and the registers of the on-chip supporting modules are initialized, and the I bit in the condition code register (CCR) is set to “1.”
- (2) The CPU loads the program counter with the first word in the vector table (stored at addresses H'0000 and H'0001) and starts program execution.

The RES pin should be held Low when power is switched off, as well as when power is switched on.

Figure 4.1 indicates the timing of the reset sequence in modes 2 and 3. Figure 4.2 indicates the timing in mode 1.

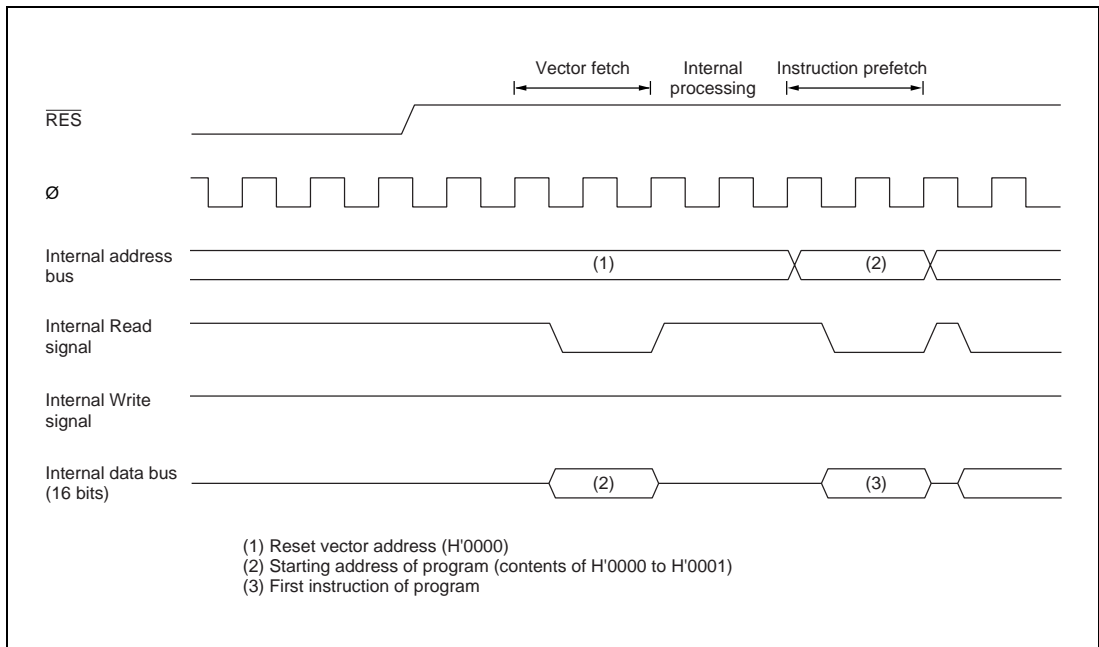

Figure 4.1 Reset Sequence (Mode 2 or 3, Program Stored in on-chip ROM)

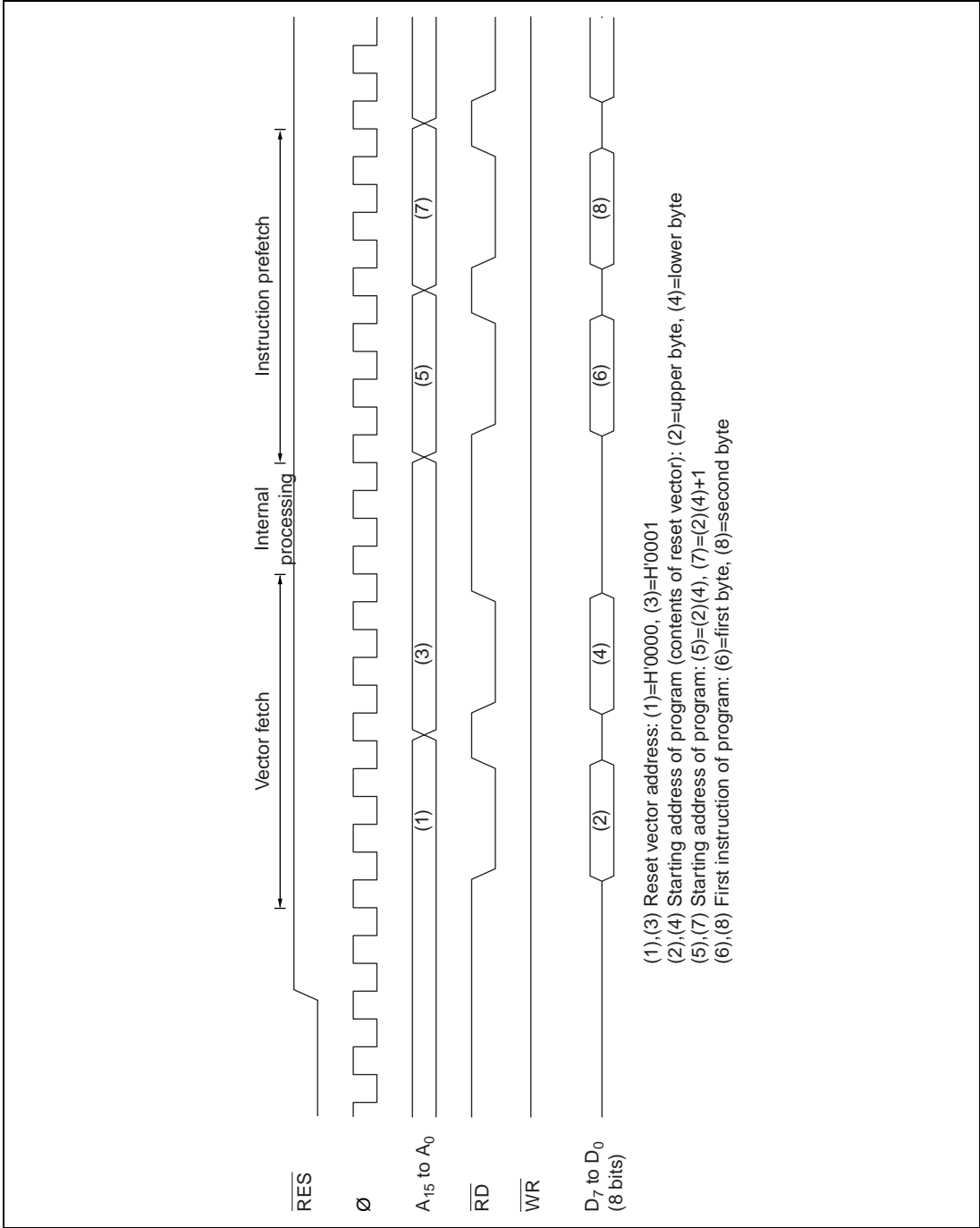

Figure 4.2 Reset Sequence (Mode 1)

4.2.3 Disabling of Interrupts after Reset

After a reset, if an interrupt were to be accepted before initialization of the stack pointer (SP: R7), the program counter and condition code register might not be saved correctly, leading to a program crash. To prevent this, all interrupts, including NMI, are disabled immediately after a reset. The first program instruction is therefore always executed. This instruction should initialize the stack pointer (example: MOV.W #xx:16, SP).

4.3 Interrupts

4.3.1 Overview

The interrupt sources include nine input pins for external interrupts (NMI, IRQ₀ to IRQ₇) and 22 internal sources in the on-chip supporting modules. Table 4.2 lists the interrupt sources in priority order and gives their vector addresses. When two or more interrupts are requested, the interrupt with highest priority is served first.

The features of these interrupts are:

- NMI has the highest priority and is always accepted. All internal and external interrupts except NMI can be masked by the I bit in the CCR. When the I bit is set to “1,” interrupts other than NMI are not accepted.
- IRQ₀ to IRQ₇ can be sensed on the falling edge of the input signal, or level-sensed. The type of sensing can be selected for each interrupt individually. NMI is edge-sensed, and either the rising or falling edge can be selected.
- All interrupts are individually vectored. The software interrupt-handling routine does not have to determine what type of interrupt has occurred.

Table 4.2 Interrupts

Interrupt source		No.	Address of Entry in Vector Table		Priority	
NMI		3	H'0006	—	H'0007	High ↑
IRQ ₀		4	H'0008	—	H'0009	
IRQ ₁		5	H'000A	—	H'000B	
IRQ ₂		6	H'000C	—	H'000D	
IRQ ₃		7	H'000E	—	H'000F	
IRQ ₄		8	H'0010	—	H'0011	
IRQ ₅		9	H'0012	—	H'0013	
IRQ ₆		10	H'0014	—	H'0015	
IRQ ₇		11	H'0016	—	H'0017	
16-Bit free-running timer	ICIA (Input capture A)	12	H'0018	—	H'0019	
	ICIB (Input capture B)	13	H'001A	—	H'001B	
	ICIC (Input capture C)	14	H'001C	—	H'001D	
	ICID (Input capture D)	15	H'001E	—	H'001F	
	OCIA (Output compare A)	16	H'0020	—	H'0021	
	OCIB (Output compare B)	17	H'0022	—	H'0023	
	FOVI (Overflow)	18	H'0024	—	H'0025	
8-Bit timer 0	CMI0A (Compare-match A)	19	H'0026	—	H'0027	
	CMI0B (Compare-match B)	20	H'0028	—	H'0029	
	OVI0 (Overflow)	21	H'002A	—	H'002B	
8-Bit timer 1	CMI1A (Compare-match A)	22	H'002C	—	H'002D	
	CMI1B (Compare-match B)	23	H'002E	—	H'002F	
	OVI1 (Overflow)	24	H'0030	—	H'0031	
Reserved		25	H'0032	—	H'0033	
		26	H'0034	—	H'0035	
Serial communication interface 0	ERI0 (Receive error)	27	H'0036	—	H'0037	
	RXI0 (Receive end)	28	H'0038	—	H'0039	
	TXI0 (TDR empty)	29	H'003A	—	H'003B	
	TEI0 (TSR empty)	30	H'003C	—	H'003D	
Serial communication interface 1	ERI1 (Receive error)	31	H'003E	—	H'003F	
	RXI1 (Receive end)	32	H'0040	—	H'0041	
	TXI1 (TDR empty)	33	H'0042	—	H'0043	
	TEI1 (TSR empty)	34	H'0044	—	H'0045	
A/D converter	ADI (Conversion end)	35	H'0046	—	H'0047	Low ↓

Notes: 1. H'0000 and H'0001 contain the reset vector.

2. H'0002 to H'0005 are reserved in the H8/338 Series and are not available to the user.

4.3.2 Interrupt-Related Registers

The interrupt-related registers are the system control register (SYSCR), IRQ sense control register (ISCR), and IRQ enable register (IER).

Table 4.3 Registers Read by Interrupt Controller

Name	Abbreviation	Read/write	Address
System control register	SYSCR	R/W	H'FFC4
IRQ sense control register	ISCR	R/W	H'FFC6
IRQ enable register	IER	R/W	H'FFC7

System Control Register (SYSCR)—H'FFC4

Bit:	7	6	5	4	3	2	1	0
	SSBY	STS2	STS1	STS0	—	NMIEG	DPME	RAME
Initial value:	0	0	0	0	1	0	0	1
Read/Write:	R/W	R/W	R/W	R/W	—	R/W	R/W	R/W

The valid edge on the NMI line is controlled by bit 2 (NMIEG) in the system control register.

Bit 2—NMI Edge (NMIEG): Determines whether a nonmaskable interrupt is generated on the falling or rising edge of the NMI input signal.

Bit 2

NMIEG	Description
0	An interrupt is generated on the falling edge of $\overline{\text{NMI}}$. (Initial state)
1	An interrupt is generated on the rising edge of $\overline{\text{NMI}}$.

See section 2.2, “System Control Register,” for information on the other SYSCR bits.

IRQ Sense Control Register (ISCR)—H'FFC6

Bit:	7	6	5	4	3	2	1	0
	IRQ ₇ SC	IRQ ₆ SC	IRQ ₅ SC	IRQ ₄ SC	IRQ ₃ SC	IRQ ₂ SC	IRQ ₁ SC	IRQ ₀ SC
Initial value:	0	0	0	0	0	0	0	0
Read/Write:	R/W	R/W	R/W	R/W	R/W	R/W	R/W	R/W

Bits 0 to 7—IRQ₀ to IRQ₇ Sense Control (IRQ₀SC to IRQ₇SC): These bits determine whether IRQ₀ to IRQ₇ are level-sensed or sensed on the falling edge.

Bits 0 to 7

IRQ ₀ SC to IRQ ₇ SC	Description
0	An interrupt is generated when $\overline{\text{IRQ}}_0$ to $\overline{\text{IRQ}}_7$ inputs are Low. (Initial state)
1	An interrupt is generated by the falling edge of the $\overline{\text{IRQ}}_0$ to $\overline{\text{IRQ}}_7$ inputs.

IRQ Enable Register (IER)—H'FFC7

Bit:	7	6	5	4	3	2	1	0
	IRQ ₇ E	IRQ ₆ E	IRQ ₅ E	IRQ ₄ E	IRQ ₃ E	IRQ ₂ E	IRQ ₁ E	IRQ ₀ E
Initial value:	0	0	0	0	0	0	0	0
Read/Write:	R/W	R/W	R/W	R/W	R/W	R/W	R/W	R/W

Bits 0 to 7—IRQ₀ to IRQ₇ Enable (IRQ₀E to IRQ₇E): These bits enable or disable the IRQ₀ to IRQ₇ interrupts individually.

Bits 0 to 7

IRQ ₀ E to IRQ ₇ E	Description
0	$\overline{\text{IRQ}}_0$ to $\overline{\text{IRQ}}_7$ interrupt requests are disabled. (Initial state)
1	$\overline{\text{IRQ}}_0$ to $\overline{\text{IRQ}}_7$ interrupt requests are enabled.

When edge sensing is selected (by setting bits IRQ₀SC to IRQ₇SC to “1”), it is possible for an interrupt-handling routine to be executed even though the corresponding enable bit (IRQ₀E to IRQ₇E) is cleared to “0” and the interrupt is disabled. If an interrupt is requested while the enable bit (IRQ₀E to IRQ₇E) is set to “1,” the request will be held pending until served. If the enable bit is cleared to “0” while the request is still pending, the request will remain pending, although new requests will not be recognized. If the interrupt mask bit (I) in the CCR is cleared to “0,” the interrupt-handling routine can be executed even though the enable bit is now “0.”

If execution of interrupt-handling routines under these conditions is not desired, it can be avoided by using the following procedure to disable and clear interrupt requests.

1. Set the I bit to “1” in the CCR, masking interrupts. Note that the I bit is set to 1 automatically when execution jumps to an interrupt vector.
2. Clear the desired bits from IRQ₀E to IRQ₇E to “0” to disable new interrupt requests.
3. Clear the corresponding IRQ₀SC to IRQ₇SC bits to “0,” then set them to “1” again. Pending IRQ_n interrupt requests are cleared when I = “1” in the CCR, IRQ_nSC = “0,” and IRQ_nE = “0.”

4.3.3 External Interrupts

The nine external interrupts are NMI and IRQ₀ to IRQ₇. NMI, IRQ₀, IRQ₁, and IRQ₂ can be used to recover from software standby mode.

(1) NMI: A nonmaskable interrupt is generated on the rising or falling edge of the NMI input signal regardless of whether the I (interrupt mask) bit is set in the CCR. The valid edge is selected by the NMIEG bit in the system control register. The NMI vector number is 3. In the NMI hardware exception-handling sequence the I bit in the CCR is set to “1.”

(2) IRQ₀ to IRQ₇: These interrupt signals are level-sensed or sensed on the falling edge of the input, as selected by ISCR bits IRQ₀SC to IRQ₇SC. These interrupts can be masked collectively by the I bit in the CCR, and can be enabled and disabled individually by setting and clearing bits IRQ₀E to IRQ₇E in the IRQ enable register.

When one of these interrupts is accepted, the I bit is set to “1.” IRQ₀ to IRQ₇ have interrupt vector numbers 4 to 11. They are prioritized in order from IRQ₇ (Low) to IRQ₀ (High). For details, see table 4.2.

Interrupts IRQ₀ to IRQ₇ do not depend on whether pins IRQ₀ to IRQ₇ are input or output pins. When using external interrupts IRQ₀ to IRQ₇, clear the corresponding DDR bits to “0” to set these pins to the input state, and do not use these pins as input or output pins for the timers, serial communication interface, or A/D converter.

4.3.4 Internal Interrupts

Twenty-two internal interrupts can be requested by the on-chip supporting modules. Each interrupt source has its own vector number, so the interrupt-handling routine does not have to determine which interrupt has occurred. All internal interrupts are masked when the I bit in the CCR is set to “1.” When one of these interrupts is accepted, the I bit is set to 1 to mask further interrupts (except NMI). The vector numbers are 12 to 35. For the priority order, see table 4.2.

4.3.5 Interrupt Handling

Interrupts are controlled by an interrupt controller that arbitrates between simultaneous interrupt requests, commands the CPU to start the hardware interrupt exception-handling sequence, and furnishes the necessary vector number. Figure 4.3 shows a block diagram of the interrupt controller.

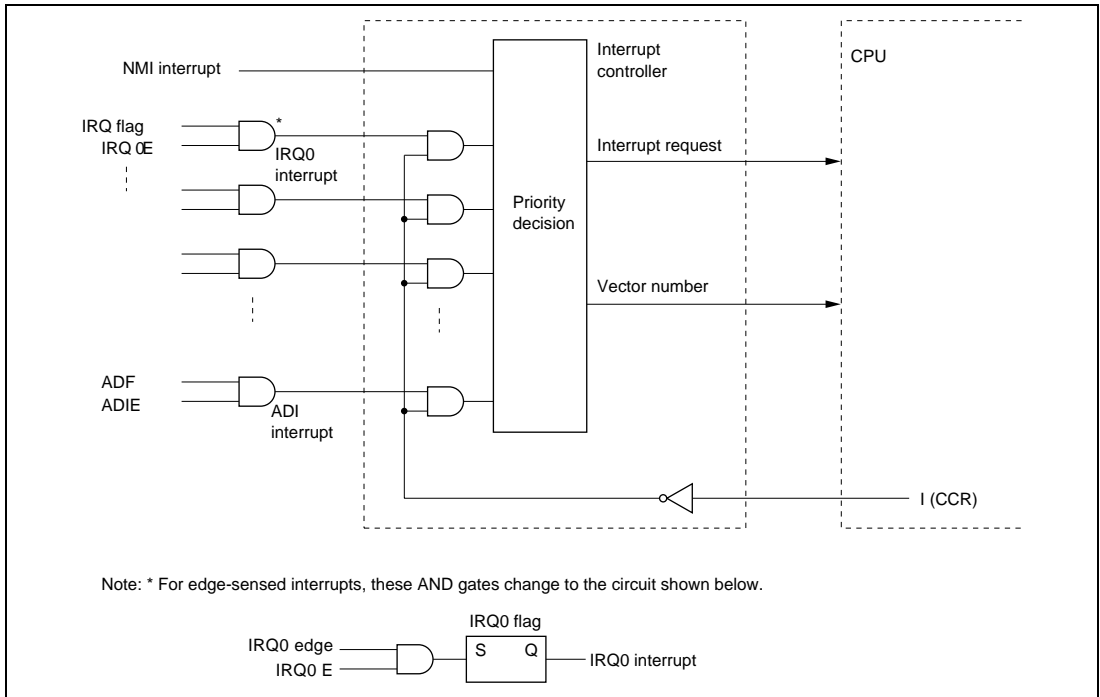

Figure 4.3 Block Diagram of Interrupt Controller

The IRQ interrupts and interrupts from the on-chip supporting modules all have corresponding enable bits. When the enable bit is cleared to “0,” the interrupt signal is not sent to the interrupt controller, so the interrupt is ignored. These interrupts can also all be masked by setting the CPU’s interrupt mask bit (I) to “1.” Accordingly, these interrupts are accepted only when their enable bit is set to “1” and the I bit is cleared to “0.”

The nonmaskable interrupt (NMI) is always accepted, except in the reset state and hardware standby mode.

When an NMI or another enabled interrupt is requested, the interrupt controller transfers the interrupt request to the CPU and indicates the corresponding vector number. (When two or more interrupts are requested, the interrupt controller selects the vector number of the interrupt with the highest priority.) When notified of an interrupt request, at the end of the current instruction or current hardware exception-handling sequence, the CPU starts the hardware exception-handling sequence for the interrupt and latches the vector number.

Figure 4.4 is a flowchart of the interrupt (and reset) operations. Figure 4.6 shows the interrupt timing sequence for the case in which the software interrupt-handling routine is in on-chip ROM and the stack is in on-chip RAM.

- (1) An interrupt request is sent to the interrupt controller when an NMI interrupt occurs, and when an interrupt occurs on an IRQ input line or in an on-chip supporting module provided the enable bit of that interrupt is set to “1.”
- (2) The interrupt controller checks the I bit in the CCR and accepts the interrupt request if the I bit is cleared to “0.” If the I bit is set to “1” only NMI requests are accepted; other interrupt requests remain pending.
- (3) Among all accepted interrupt requests, the interrupt controller selects the request with the highest priority and passes it to the CPU. Other interrupt requests remain pending.
- (4) When it receives the interrupt request, the CPU waits until completion of the current instruction or hardware exception-handling sequence, then starts the hardware exception-handling sequence for the interrupt and latches the interrupt vector number.
- (5) In the hardware exception-handling sequence, the CPU first pushes the PC and CCR onto the stack. See figure 4.5. The stacked PC indicates the address of the first instruction that will be executed on return from the software interrupt-handling routine.
- (6) Next the I bit in the CCR is set to “1,” masking all further interrupts except NMI.
- (7) The vector address corresponding to the vector number is generated, the vector table entry at this vector address is loaded into the program counter, and execution branches to the software interrupt-handling routine at the address indicated by that entry.

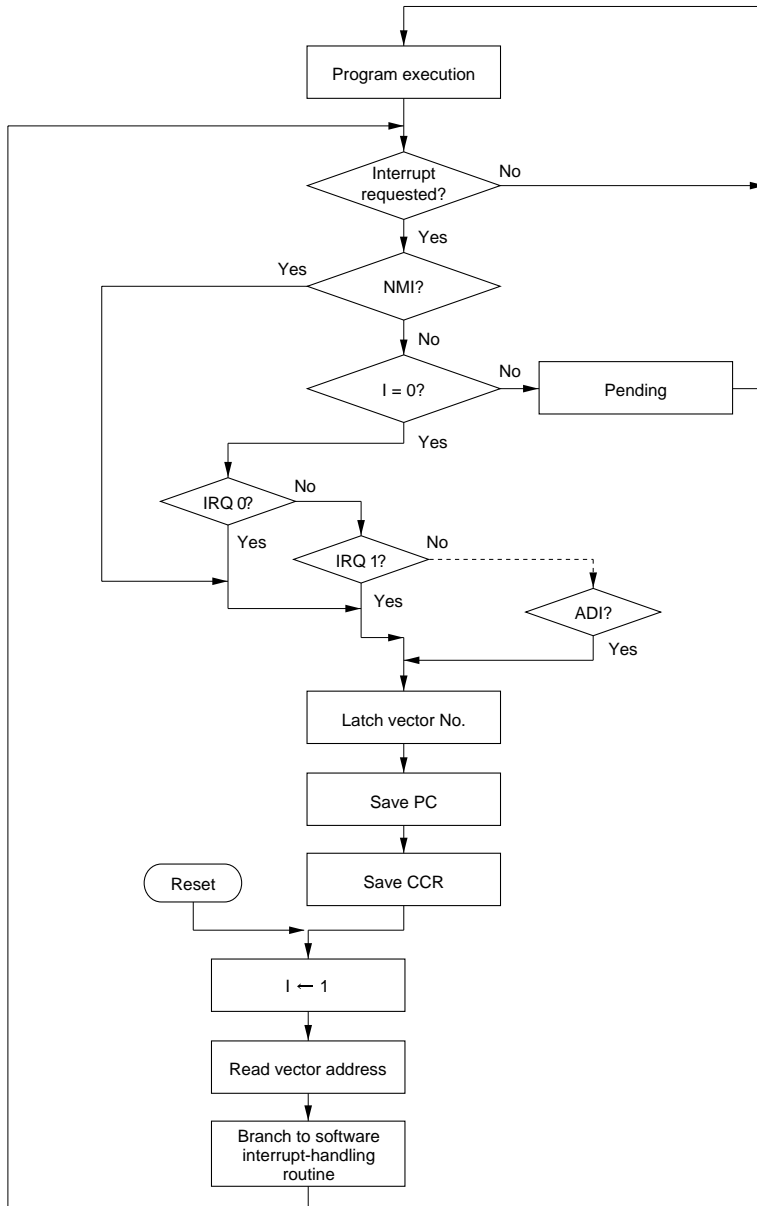

Figure 4.4 Hardware Interrupt-Handling Sequence

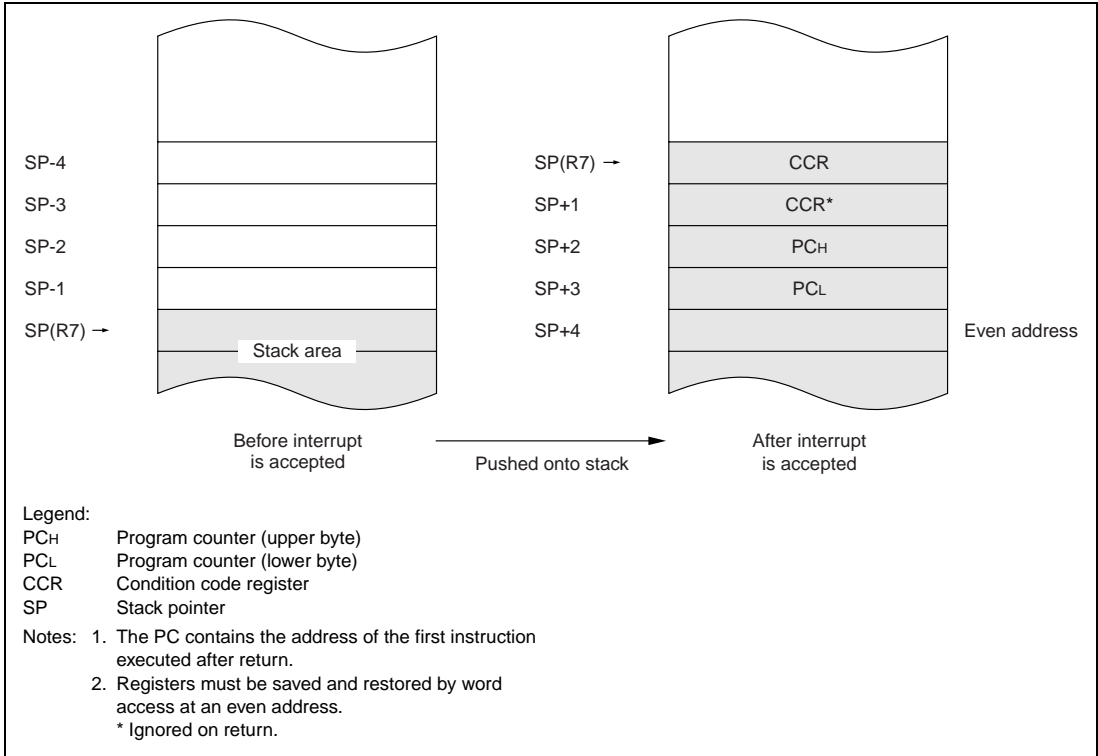

Figure 4.5 Usage of Stack in Interrupt Handling

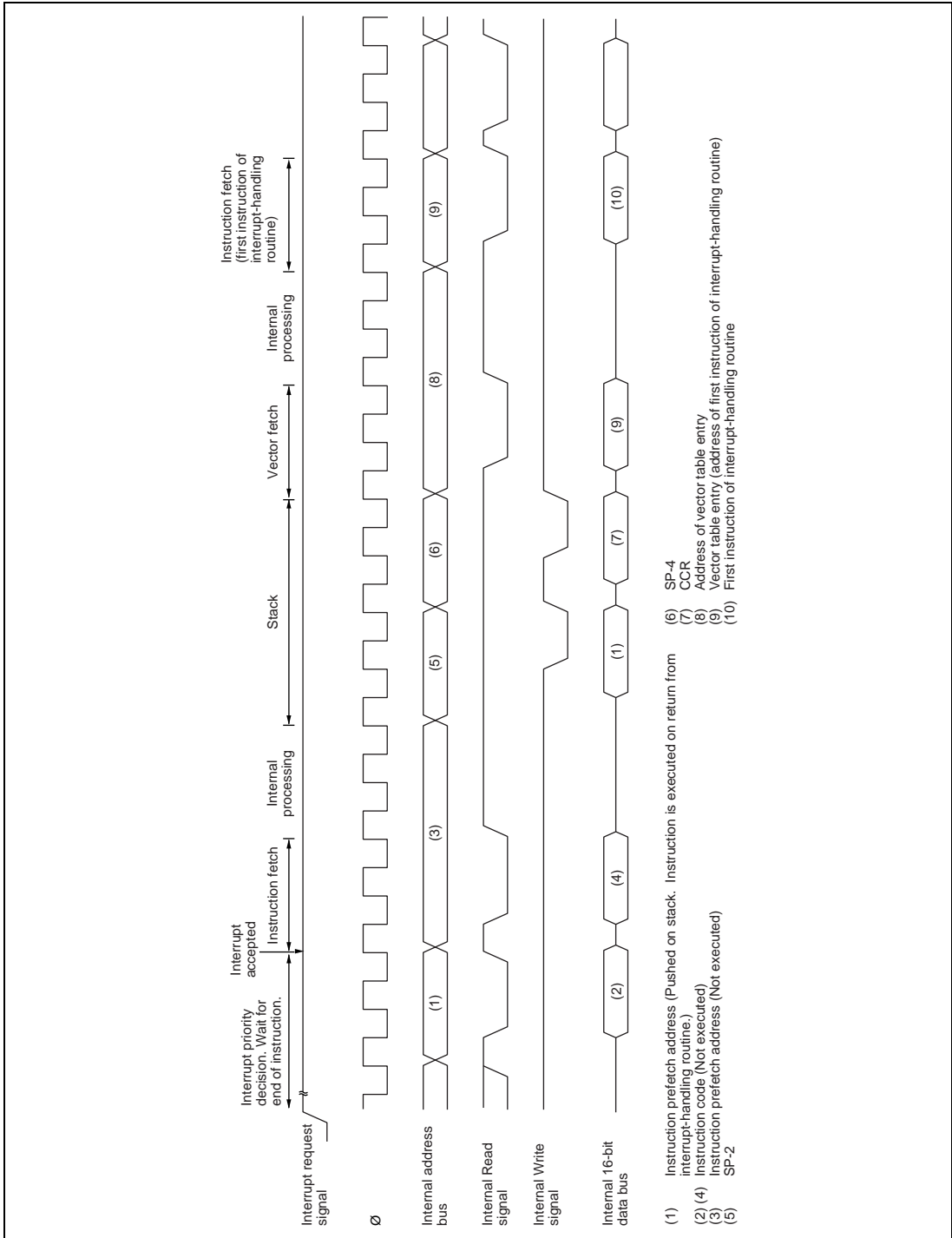

Figure 4.6 Timing of Interrupt Sequence

4.3.6 Interrupt Response Time

Table 4.4 indicates the number of states that elapse from an interrupt request signal until the first instruction of the software interrupt-handling routine is executed. Since on-chip memory is accessed 16 bits at a time, very fast interrupt service can be obtained by placing interrupt-handling routines in on-chip ROM and the stack in on-chip RAM.

Table 4.4 Number of States before Interrupt Service

No.	Reason for Wait	Number of States	
		On-Chip Memory	External Memory
1	Interrupt priority decision	2* ³	2* ³
2	Wait for completion of current instruction* ¹	1 to 13	5 to 17* ²
3	Save PC and CCR	4	12* ²
4	Fetch vector	2	6* ²
5	Fetch instruction	4	12* ²
6	Internal processing	4	4
	Total	17 to 29	41 to 53 * ²

- Notes: 1. These values do not apply if the current instruction is EEPMOV.
 2. If wait states are inserted in external memory access, add the number of wait states.
 3. 1 for internal interrupts.

4.3.7 Precaution

Note that the following type of contention can occur in interrupt handling.

Contention between Interrupt Request and Disable: When software clears the enable bit of an interrupt to “0” to disable the interrupt, the interrupt becomes disabled after execution of the clearing instruction. If an enable bit is cleared by a BCLR or MOV instruction, for example, and the interrupt is requested during execution of that instruction, at the instant when the instruction ends the interrupt is still enabled, so after execution of the instruction, the hardware exception-handling sequence is executed for the interrupt. If a higher-priority interrupt is requested at the same time, however, the hardware exception-handling sequence is executed for the higher-priority interrupt and the interrupt that was disabled is ignored.

Similar considerations apply when an interrupt request flag is cleared to “0.”

Figure 4.7 shows an example in which the OCIAE bit is cleared to “0.”

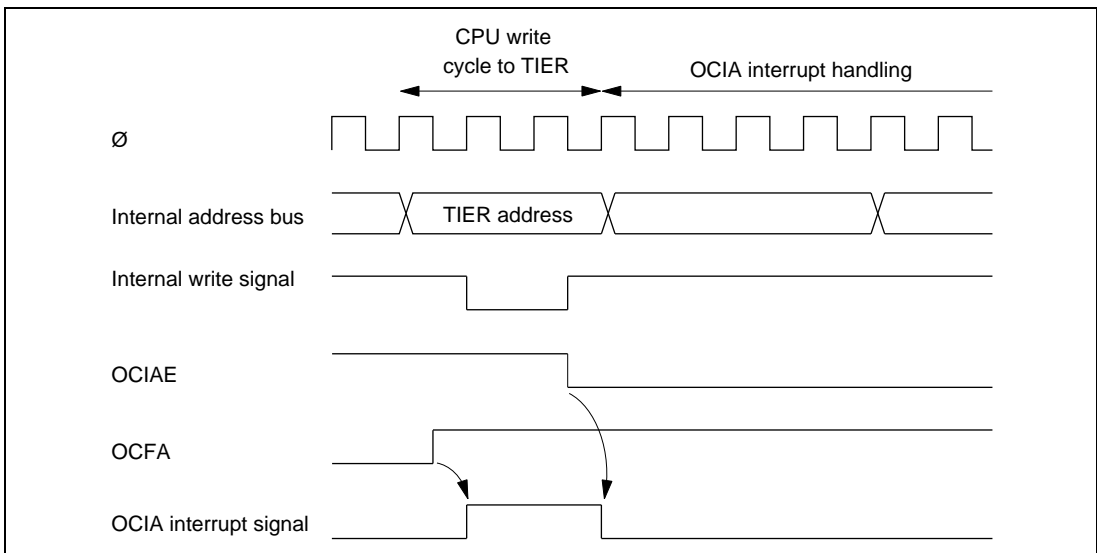

Figure 4.7 Contention between Interrupt and Disabling Instruction

The above contention does not occur if the enable bit or flag is cleared to “0” while the interrupt mask bit (I) is set to “1.”

4.4 Note on Stack Handling

In word access, the least significant bit of the address is always assumed to be 0. The stack is always accessed by word access. Care should be taken to keep an even value in the stack pointer (general register R7). Use the PUSH and POP (or MOV.W Rn, @-SP and MOV.W @SP+, Rn) instructions to push and pop registers on the stack.

Setting the stack pointer to an odd value can cause programs to crash. Figure 4.8 shows an example of damage caused when the stack pointer contains an odd address.

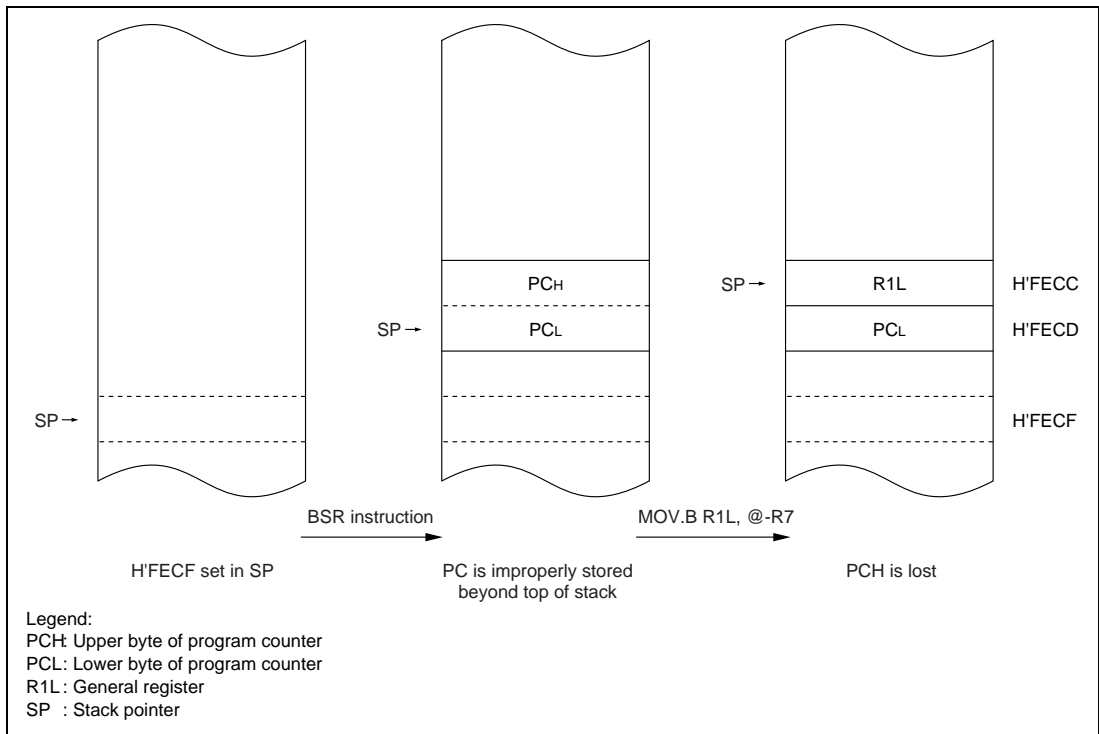

Figure 4.8 Example of Damage Caused by Setting an Odd Address in R7

Although the CCR consists of only one byte, it is treated as word data when pushed on the stack. In the hardware interrupt exception-handling sequence, two identical CCR bytes are pushed onto the stack to make a complete word. When popped from the stack by an RTE instruction, the CCR is loaded from the byte stored at the even address. The byte stored at the odd address is ignored.

Section 5 Clock Pulse Generator

5.1 Overview

The H8/338 Series has a built-in clock pulse generator (CPG) consisting of an oscillator circuit, a system (ϕ) clock divider, and a prescaler. The prescaler generates clock signals for the on-chip supporting modules.

5.1.1 Block Diagram

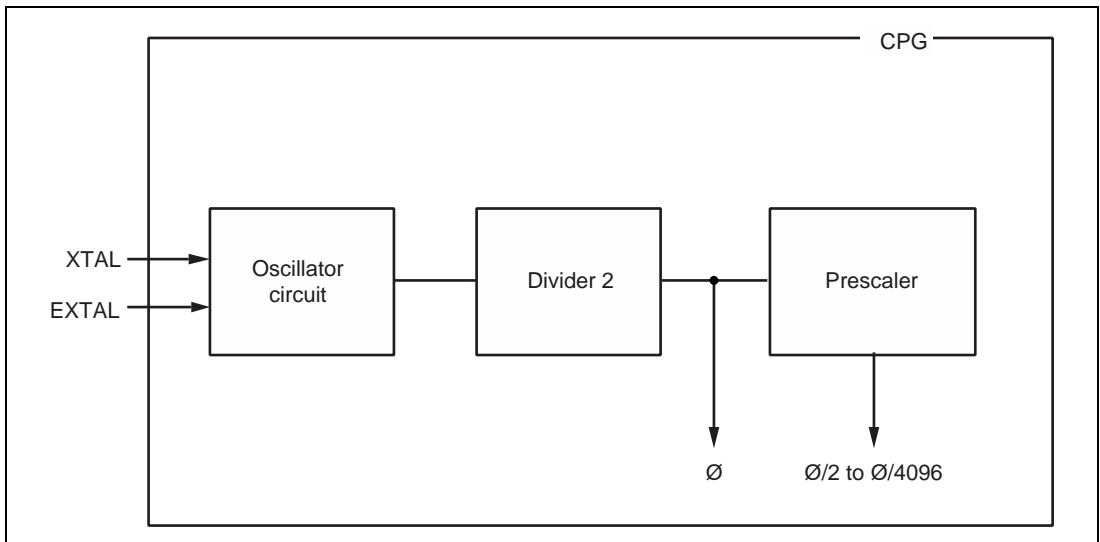

Figure 5.1 Block Diagram of Clock Pulse Generator

5.2 Oscillator Circuit

If an external crystal is connected across the EXTAL and XTAL pins, the on-chip oscillator circuit generates a clock signal for the system clock divider. Alternatively, an external clock signal can be applied to the EXTAL pin.

(1) Connecting an External Crystal

- ① **Circuit Configuration:** An external crystal can be connected as in the example in figure 5.2. An AT-cut parallel resonating crystal should be used.

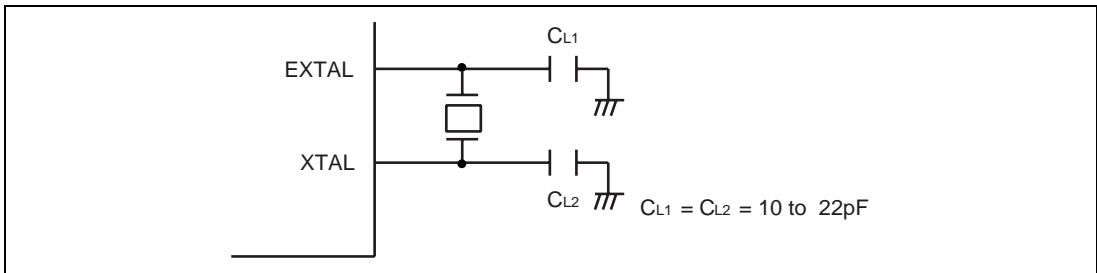

Figure 5.2 Connection of Crystal Oscillator (Example)

- ② **Crystal Oscillator:** The external crystal should have the characteristics listed in table 5.1.

Table 5.1 External Crystal Parameters

Frequency (MHz)	2	4	8	12	16	20
Rs max (Ω)	500	120	60	40	30	20
C0 (pF)	7 pF max					

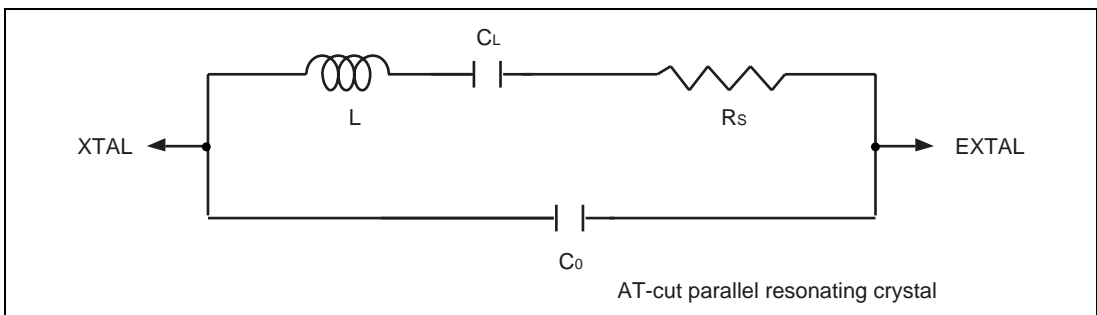

Figure 5.3 Equivalent Circuit of External Crystal

- ③ **Note on Board Design:** When an external crystal is connected, other signal lines should be kept away from the crystal circuit to prevent induction from interfering with correct oscillation. See figure 5.4. The crystal and its load capacitors should be placed as close as possible to the XTAL and EXTAL pins.

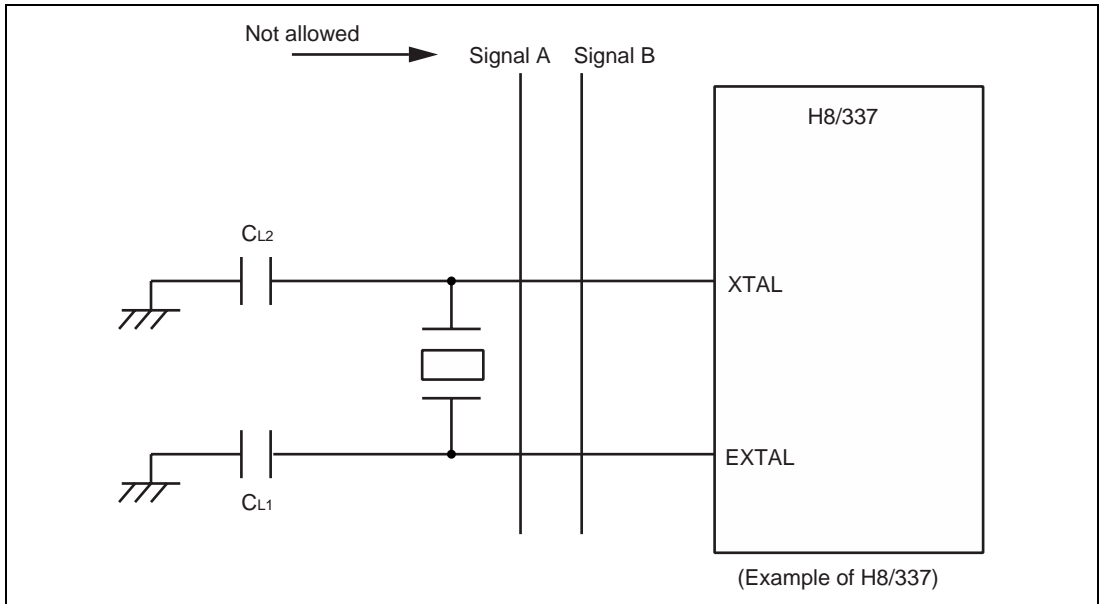

Figure 5.4 Notes on Board Design around External Crystal

(2) Input of External Clock Signal

- ① **Circuit Configuration:** An external clock signal can be input as shown in the examples in figure 5.5. In example (b) in figure 5.5, the external clock signal should be kept high during standby.

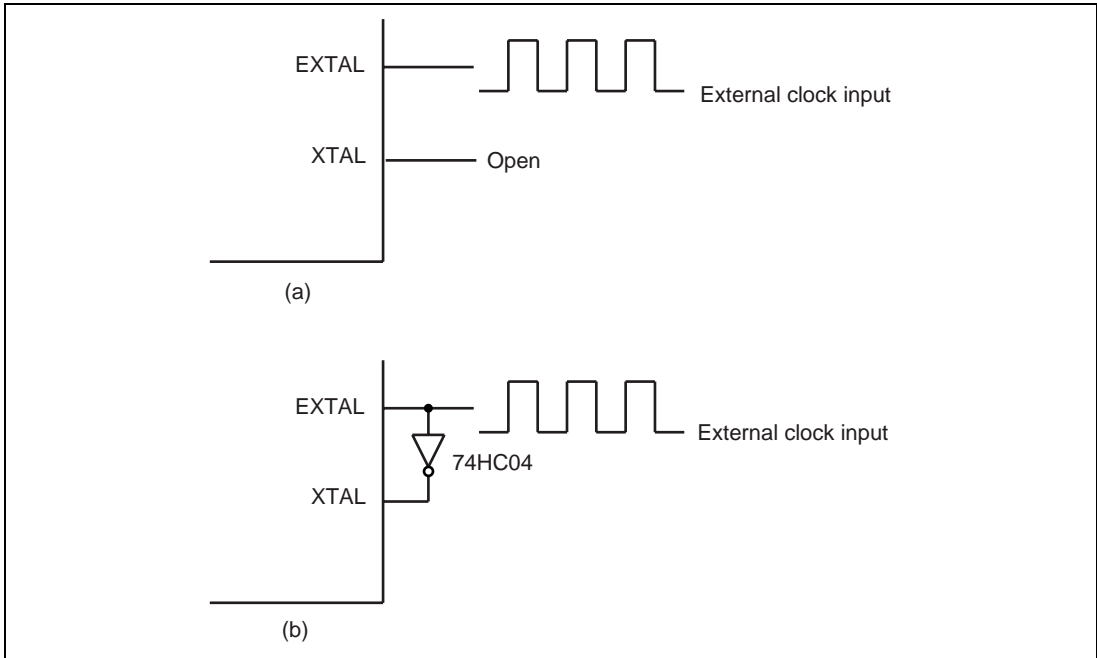

Figure 5.5 External Clock Input (Example)

② External Clock Input

Frequency	Double the system clock (ϕ) frequency
Duty factor	45% to 55%

5.3 System Clock Divider

The system clock divider divides the crystal oscillator or external clock frequency by 2 to create the system clock (ϕ).

Section 6 I/O Ports

6.1 Overview

The H8/338 Series has nine parallel I/O ports, including:

- Six 8-bit input/output ports—ports 1, 2, 3, 4, 6, and 9
- One 8-bit input port—port 7
- One 7-bit input/output port—port 8
- One 3-bit input/output port—port 5

Ports 1, 2, and 3 have programmable input pull-up transistors. Ports 1 to 6, 8, and 9 can drive a Darlington pair. Ports 1 to 4, 6, and 9 can drive one TTL load and a 90pF capacitive load. Ports 5 and 8 can drive one TTL load and a 30pF capacitive load. Ports 1 and 2 can drive LEDs (10mA current sink).

Input and output are memory-mapped. The CPU views each port as a data register (DR) located in the register field at the high end of the address space. Each port (except port 7) also has a data direction register (DDR) which determines which pins are used for input and which for output.

Output: To send data to an output port, the CPU selects output in the data direction register and writes the desired data in the data register, causing the data to be held in a latch. The latch output drives the pin through a buffer amplifier. If the CPU reads the data register of an output port, it obtains the data held in the latch rather than the actual level of the pin.

Input: To read data from an I/O port, the CPU selects input in the data direction register and reads the data register. This causes the input logic level at the pin to be placed directly on the internal data bus. There is no intervening input latch.

The data direction registers are write-only registers; their contents are invisible to the CPU. If the CPU reads a data direction register all bits are read as “1,” regardless of their true values. Care is required if bit manipulation instructions are used to set and clear the data direction bits. See the note on bit manipulation instructions in section 3.5.5, “Bit Manipulations.”

Auxiliary Functions: In addition to their general-purpose input/output functions, all of the I/O ports have auxiliary functions. Most of the auxiliary functions are software-selectable and must be enabled by setting bits in control registers. When selected, an auxiliary function usually replaces the general-purpose input/output function, but in some cases both functions can operate simultaneously. Table 6.1 summarizes the functions of the ports.

Table 6.1 Port Functions

Port	Description	Pins	Expanded Modes		Single-Chip Mode
			Mode 1	Mode 2	Mode 3
Port 1	<ul style="list-style-type: none"> 8-bit input-output port Can drive LEDs Input pull-ups 	P1 ₇ to P1 ₀ / A ₇ to A ₀	Address output (low)	General input when DDR = "0" (initial state) Address output (low) when DDR = "1"	General input/output
Port 2	<ul style="list-style-type: none"> 8-bit input-output port Can drive LEDs Input pull-ups 	P2 ₇ to P2 ₀ / A ₁₅ to A ₈	Address output (high)	General input when DDR = "0" (initial state) Address output (high) when DDR = "1"	General input/output
Port 3	<ul style="list-style-type: none"> 8-bit input-output port Input pull-ups 	P3 ₇ to P3 ₀ / D ₇ to D ₀	Data bus	Data bus	General input/output
Port 4	<ul style="list-style-type: none"> 8-bit input-output port 	P4 ₇ to P4 ₀	General input/output, 8-bit timer 0/1 input/output (TMCI ₀ , TMO ₀ , TMRI ₀ , TMCI ₁ , TMO ₁ , TMRI ₁), or PWM timer 0/1 output (PW ₀ , PW ₁)		
Port 5	<ul style="list-style-type: none"> 3-bit input-output port 	P5 ₂ to P5 ₀	General input/output or serial communication interface 0 input/output (TxD ₀ , RxD ₀ , SCK ₀)		
Port 6	<ul style="list-style-type: none"> 8-bit input-output port 	P6 ₇ to P6 ₀	General input/output, 16-bit free-running timer input/output (FTCI, FTOA, FTOB, FTIA, FTIB, FTIC, FTID), or external interrupt input (IRQ ₆ , $\overline{\text{IRQ}}_7$)		

Table 6.1 Port Functions (cont)

Port	Description	Pins	Expanded Modes		Single-Chip Mode
			Mode 1	Mode 2	Mode 3
Port 7	• 8-bit input port	P7 ₇ to P7 ₀	General input, analog input to A/D converter (AN ₇ to AN ₀), or analog output from D/A converter (DA ₀ , DA ₁)		
Port 8	• 7-bit input-output port	P8 ₆ /SCK ₁ / IRQ ₅	General input/output, serial communication interface 1 input/output (TxD ₁ , RxD ₁ , SCK ₁), or external interrupt input (IRQ ₃ , IRQ ₄ , IRQ ₅)		
		P8 ₅ /RxD ₁ / IRQ ₄ P8 ₄ /TxD ₁ / IRQ ₃ P8 ₃ to P8 ₀	General input/output		
Port 9	• 8-bit input-output port	P9 ₇ /WAIT	WAIT input		General input/output
		P9 ₆ /φ	System clock output		General input when DDR = "0" (initial state) System clock output when DDR = "1"
		P9 ₅ /AS	AS output		General input/output
		P9 ₄ /WR	WR output		
		P9 ₃ /RD	RD output		
		P9 ₂ /IRQ ₀ P9 ₁ /IRQ ₁	General input/output or external interrupt input (IRQ ₀ , IRQ ₁)		
		P9 ₀ /ADTRG/ IRQ ₂	General input/output, A/D converter trigger input (ADTRG), or external interrupt input (IRQ ₂)		

6.2 Port 1

Port 1 is an 8-bit input/output port that also provides the low bits of the address bus. The function of port 1 depends on the MCU mode as indicated in table 6.2.

Table 6.2 Functions of Port 1

Mode 1	Mode 2	Mode 3
Address bus (Low) (A ₇ to A ₀)	Input port or Address bus (Low) (A ₇ to A ₀)*	Input/output port

Note: Depending on the bit settings in the data direction register: 0—input pin; 1—address pin

Pins of port 1 can drive a single TTL load and a 90pF capacitive load when they are used as output pins. They can also drive light-emitting diodes and a Darlington pair. When they are used as input pins, they have programmable MOS transistor pull-ups.

Table 6.3 details the port 1 registers.

Table 6.3 Port 1 Registers

Name	Abbreviation	Read/Write	Initial Value	Address
Port 1 data direction register	P1DDR	W	H'FF (mode 1) H'00 (modes 2 and 3)	H'FFB0
Port 1 data register	P1DR	R/W	H'00	H'FFB2
Port 1 input pull-up control register	P1PCR	R/W	H'00	H'FFAC

Port 1 Data Direction Register (P1DDR)—H'FFB0

Bit	7	6	5	4	3	2	1	0
	P1 ₇ DDR	P1 ₆ DDR	P1 ₅ DDR	P1 ₄ DDR	P1 ₃ DDR	P1 ₂ DDR	P1 ₁ DDR	P1 ₀ DDR
Mode 1								
Initial value	1	1	1	1	1	1	1	1
Read/Write	—	—	—	—	—	—	—	—
Modes 2 and 3								
Initial value	0	0	0	0	0	0	0	0
Read/Write	W	W	W	W	W	W	W	W

P1DDR is an 8-bit register that selects the direction of each pin in port 1. A pin functions as an output pin if the corresponding bit in P1DDR is set to “1,” and as an input pin if the bit is cleared to “0.”

Port 1 Data Register (P1DR)—H'FFB2

Bit:	7	6	5	4	3	2	1	0
	P1 ₇	P1 ₆	P1 ₅	P1 ₄	P1 ₃	P1 ₂	P1 ₁	P1 ₀
Initial value:	0	0	0	0	0	0	0	0
Read/Write:	R/W	R/W	R/W	R/W	R/W	R/W	R/W	R/W

P1DR is an 8-bit register containing the data for pins P1₇ to P1₀. When the CPU reads P1DR, for output pins it reads the value in the P1DR latch, but for input pins, it obtains the logic level directly from the pin, bypassing the P1DR latch.

Port 1 Input Pull-Up Control Register (P1PCR)—H'FFAC

Bit:	7	6	5	4	3	2	1	0
	P1 ₇ PCR	P1 ₆ PCR	P1 ₅ PCR	P1 ₄ PCR	P1 ₃ PCR	P1 ₂ PCR	P1 ₁ PCR	P1 ₀ PCR
Initial value:	0	0	0	0	0	0	0	0
Read/Write:	R/W	R/W	R/W	R/W	R/W	R/W	R/W	R/W

P1PCR is an 8-bit readable/writable register that controls the input pull-up transistors in port 1. If a bit in P1DDR is cleared to “0” (designating input) and the corresponding bit in P1PCR is set to “1,” the input pull-up transistor for that bit is turned on.

Mode 1: In mode 1 (expanded mode without on-chip ROM), port 1 is automatically used for address output. The port 1 data direction register is unwritable. All bits in P1DDR are automatically set to “1” and cannot be cleared to “0.”

Mode 2: In mode 2 (expanded mode with on-chip ROM), the usage of port 1 can be selected on a pin-by-pin basis. A pin is used for general-purpose input if its data direction bit is cleared to “0,” or for address output if its data direction bit is set to “1.”

Mode 3: In the single-chip mode port 1 is a general-purpose input/output port.

Reset: A reset clears P1DDR, P1DR, and P1PCR to all “0,” placing all pins in the input state with the pull-up transistors off. In mode 1, when the chip comes out of reset, P1DDR is set to all “1.”

Hardware Standby Mode: All pins are placed in the high-impedance state with the pull-up transistors off. P1DR and P1PCR are initialized to H'00. In modes 2 and 3, P1DDR is initialized to H'00.

Software Standby Mode: In the software standby mode, P1DDR, P1DR, and P1PCR remain in their previous state. Address output pins are Low. General-purpose output pins continue to output the data in P1DR.

Input Pull-Up Transistors: Port 1 has built-in programmable input pull-up transistors that are available in modes 2 and 3. The pull-up for each bit can be turned on and off individually. To turn on an input pull-up in mode 2 or 3, set the corresponding P1PCR bit to “1” and clear the corresponding P1DDR bit to “0.” P1PCR is cleared to H'00 by a reset and in the hardware standby mode, turning all input pull-ups off. In software standby mode, the previous state is maintained.

Table 6.4 indicates the states of the input pull-up transistors in each operating mode.

Table 6.4 States of Input Pull-Up Transistors (Port 1)

Mode	Reset	Hardware Standby	Software Standby	Other Operating Modes
1	Off	Off	Off	Off
2	Off	Off	On/off	On/off
3	Off	Off	On/off	On/off

Notes: Off: The input pull-up transistor is always off.

On/off: The input pull-up transistor is on if P1PCR = “1” and P1DDR = “0,” but off otherwise.

Figure 6.1 shows a schematic diagram of port 1.

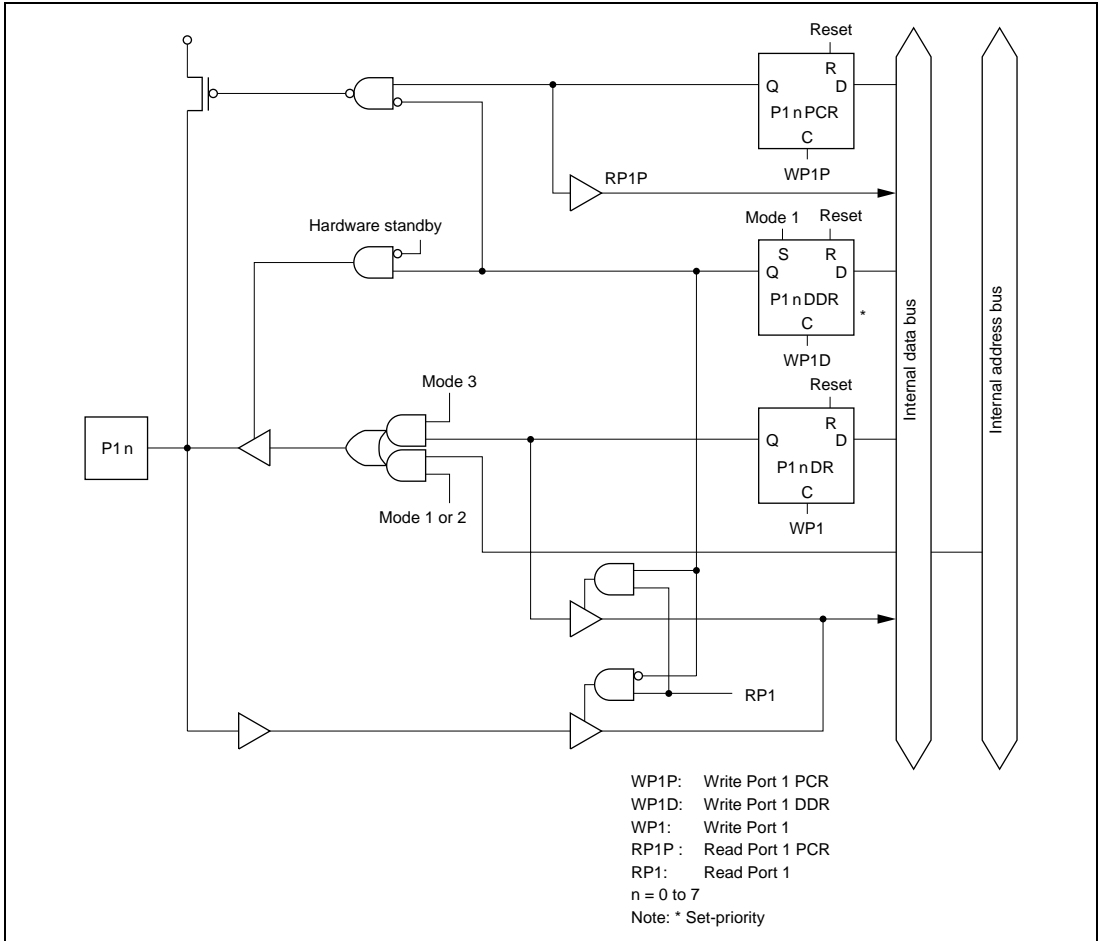

Figure 6.1 Port 1 Schematic Diagram

6.3 Port 2

Port 2 is an 8-bit input/output port that also provides the high bits of the address bus. The function of port 2 depends on the MCU mode as indicated in table 6.5.

Table 6.5 Functions of Port 2

Mode 1	Mode 2	Mode 3
Address bus (High) (A ₁₅ to A ₈)	Input port or Address bus (High) (A ₁₅ to A ₈)*	Input/output port

Note: Depending on the bit settings in the data direction register: 0—input pin; 1—address pin

Pins of port 2 can drive a single TTL load and a 90pF capacitive load when they are used as output pins. They can also drive light-emitting diodes and a Darlington pair. When they are used as input pins, they have programmable MOS transistor pull-ups.

Table 6.6 details the port 2 registers.

Table 6.6 Port 2 Registers

Name	Abbreviation	Read/Write	Initial Value	Address
Port 2 data direction register	P2DDR	W	H'FF (mode 1) H'00 (modes 2 and 3)	H'FFB1
Port 2 data register	P2DR	R/W	H'00	H'FFB3
Port 2 input pull-up control register	P2PCR	R/W	H'00	H'FFAD

Port 2 Data Direction Register (P2DDR)—H'FFB1

Bit	7	6	5	4	3	2	1	0
	P2 ₇ DDR	P2 ₆ DDR	P2 ₅ DDR	P2 ₄ DDR	P2 ₃ DDR	P2 ₂ DDR	P2 ₁ DDR	P2 ₀ DDR
Mode 1								
Initial value	1	1	1	1	1	1	1	1
Read/Write	—	—	—	—	—	—	—	—
Modes 2 and 3								
Initial value	0	0	0	0	0	0	0	0
Read/Write	W	W	W	W	W	W	W	W

P2DDR is an 8-bit register that selects the direction of each pin in port 2. A pin functions as an output pin if the corresponding bit in P2DDR is set to “1,” and as an input pin if the bit is cleared to “0.”

Port 2 Data Register (P2DR)—H'FFB3

Bit:	7	6	5	4	3	2	1	0
	P2 ₇	P2 ₆	P2 ₅	P2 ₄	P2 ₃	P2 ₂	P2 ₁	P2 ₀
Initial value:	0	0	0	0	0	0	0	0
Read/Write:	R/W	R/W	R/W	R/W	R/W	R/W	R/W	R/W

P2DR is an 8-bit register containing the data for pins P2₇ to P2₀. When the CPU reads P2DR, for output pins it reads the value in the P2DR latch, but for input pins, it obtains the logic level directly from the pin, bypassing the P2DR latch.

Port 2 Input Pull-Up Control Register (P2PCR)—H'FFAD

Bit:	7	6	5	4	3	2	1	0
	P2 ₇ PCR	P2 ₆ PCR	P2 ₅ PCR	P2 ₄ PCR	P2 ₃ PCR	P2 ₂ PCR	P2 ₁ PCR	P2 ₀ PCR
Initial value:	0	0	0	0	0	0	0	0
Read/Write:	R/W	R/W	R/W	R/W	R/W	R/W	R/W	R/W

P2PCR is an 8-bit readable/writable register that controls the input pull-up transistors in port 2. If a bit in P2DDR is cleared to “0” (designating input) and the corresponding bit in P2PCR is set to “1,” the input pull-up transistor for that bit is turned on.

Mode 1: In mode 1 (expanded mode without on-chip ROM), port 2 is automatically used for address output. The port 2 data direction register is unwritable. All bits in P2DDR are automatically set to “1” and cannot be cleared to “0.”

Mode 2: In mode 2 (expanded mode with on-chip ROM), the usage of port 2 can be selected on a pin-by-pin basis. A pin is used for general-purpose input if its data direction bit is cleared to “0,” or for address output if its data direction bit is set to “1.”

Mode 3: In the single-chip mode port 2 is a general-purpose input/output port.

Reset: A reset clears P2DDR, P2DR, and P2PCR to all “0,” placing all pins in the input state with the pull-up transistors off. In mode 1, when the chip comes out of reset, P2DDR is set to all “1.”

Hardware Standby Mode: All pins are placed in the high-impedance state with the pull-up transistors off. P2DR and P2PCR are initialized to H'00. In modes 2 and 3, P2DDR is initialized to H'00.

Software Standby Mode: In the software standby mode, P2DDR, P2DR, and P2PCR remain in their previous state. Address output pins are Low. General-purpose output pins continue to output the data in P2DR.

Input Pull-Up Transistors: Port 2 has built-in programmable input pull-up transistors that are available in modes 2 and 3. The pull-up for each bit can be turned on and off individually. To turn on an input pull-up in mode 2 or 3, set the corresponding P2PCR bit to “1” and clear the corresponding P2DDR bit to “0.” P2PCR is cleared to H’00 by a reset and in the hardware standby mode, turning all input pull-ups off. In software standby mode, the previous state is maintained.

Table 6.7 indicates the states of the input pull-up transistors in each operating mode.

Table 6.7 States of Input Pull-Up Transistors (Port 2)

Mode	Reset	Hardware Standby	Software Standby	Other Operating Modes
1	Off	Off	Off	Off
2	Off	Off	On/off	On/off
3	Off	Off	On/off	On/off

Notes: Off: The input pull-up transistor is always off.

On/off: The input pull-up transistor is on if P2PCR = “1” and P2DDR = “0,” but off otherwise.

Figure 6.2 shows a schematic diagram of port 2.

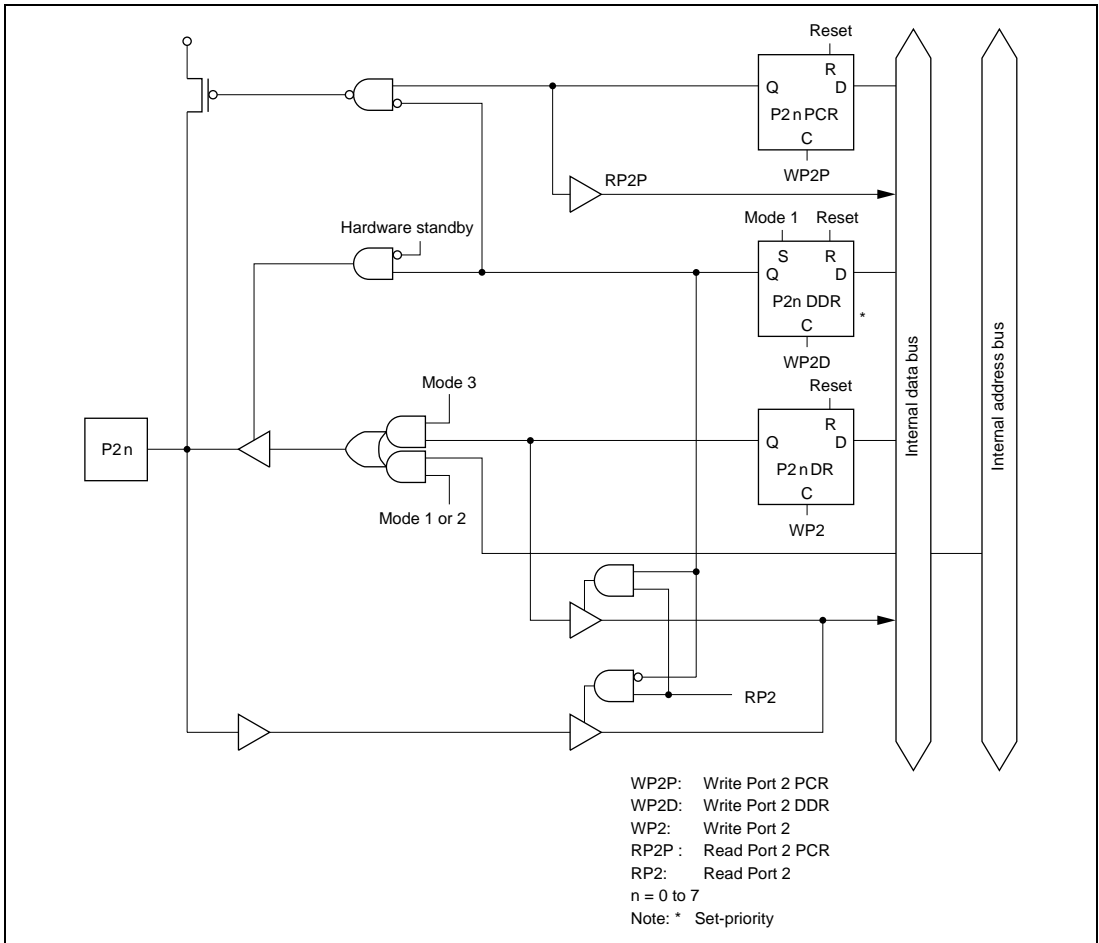

Figure 6.2 Port 2 Schematic Diagram

6.4 Port 3

Port 3 is an 8-bit input/output port that also provides the external data bus. The function of port 3 depends on the MCU mode as indicated in table 6.8.

Table 6.8 Functions of Port 3

Mode 1	Mode 2	Mode 3
Data bus	Data bus	Input/output port

Pins of port 3 can drive a single TTL load and a 90pF capacitive load when they are used as output pins. They can also drive a Darlington pair. When they are used as input pins, they have programmable MOS transistor pull-ups.

Table 6.9 details the port 3 registers.

Table 6.9 Port 3 Registers

Name	Abbreviation	Read/Write	Initial Value	Address
Port 3 data direction register	P3DDR	W	H'00	H'FFB4
Port 3 data register	P3DR	R/W	H'00	H'FFB6
Port 3 input pull-up control register	P3PCR	R/W	H'00	H'FFAE

Port 3 Data Direction Register (P3DDR)—H'FFB4

Bit:	7	6	5	4	3	2	1	0
	P3 ₇ DDR	P3 ₆ DDR	P3 ₅ DDR	P3 ₄ DDR	P3 ₃ DDR	P3 ₂ DDR	P3 ₁ DDR	P3 ₀ DDR
Initial value:	0	0	0	0	0	0	0	0
Read/Write:	W	W	W	W	W	W	W	W

P3DDR is an 8-bit register that selects the direction of each pin in port 3. A pin functions as an output pin if the corresponding bit in P3DDR is set to “1,” and as an input pin if the bit is cleared to “0.”

Port 3 Data Register (P3DR)—H'FFB6

Bit:	7	6	5	4	3	2	1	0
	P3 ₇	P3 ₆	P3 ₅	P3 ₄	P3 ₃	P3 ₂	P3 ₁	P3 ₀
Initial value:	0	0	0	0	0	0	0	0
Read/Write:	R/W	R/W	R/W	R/W	R/W	R/W	R/W	R/W

P3DR is an 8-bit register containing the data for pins P3₇ to P3₀. When the CPU reads P3DR, for output pins it reads the value in the P3DR latch, but for input pins, it obtains the logic level directly from the pin, bypassing the P3DR latch.

Port 3 Input Pull-Up Control Register (P3PCR)—H'FFAE

Bit:	7	6	5	4	3	2	1	0
	P3 ₇ PCR	P3 ₆ PCR	P3 ₅ PCR	P3 ₄ PCR	P3 ₃ PCR	P3 ₂ PCR	P3 ₁ PCR	P3 ₀ PCR
Initial value:	0	0	0	0	0	0	0	0
Read/Write:	R/W	R/W	R/W	R/W	R/W	R/W	R/W	R/W

P3PCR is an 8-bit readable/writable register that controls the input pull-up transistors in port 3. If a bit in P3DDR is cleared to “0” (designating input) and the corresponding bit in P3PCR is set to “1,” the input pull-up transistor for that bit is turned on.

Modes 1 and 2: In the expanded modes, port 3 is automatically used as the data bus. The values in P3DDR, P3DR, and P3PCR are ignored.

Mode 3: In the single-chip mode, port 3 can be used as a general-purpose input/output port.

Reset and Hardware Standby Mode: A reset or entry to the hardware standby mode clears P3DDR, P3DR, and P3PCR to all “0.” All pins are placed in the high-impedance state with the pull-up transistors off.

Software Standby Mode: In the software standby mode, P3DDR, P3DR, and P3PCR remain in their previous state. In modes 1 and 2, all pins are placed in the data input (high-impedance) state. In mode 3, all pins remain in their previous input or output state.

Input Pull-Up Transistors: Port 3 has built-in programmable input pull-up transistors that are available in mode 3. The pull-up for each bit can be turned on and off individually. To turn on an input pull-up in mode 3, set the corresponding P3PCR bit to “1” and clear the corresponding P3DDR bit to “0.” P3PCR is cleared to H'00 by a reset and in the hardware standby mode, turning all input pull-ups off. In software standby mode, the previous state is maintained.

Table 6.10 indicates the states of the input pull-up transistors in each operating mode.

Table 6.10 States of Input Pull-Up Transistors (Port 3)

Mode	Reset	Hardware Standby	Software Standby	Other Operating Modes
1	Off	Off	Off	Off
2	Off	Off	Off	Off
3	Off	Off	On/off	On/off

Notes: Off: The input pull-up transistor is always off.

On/off: The input pull-up transistor is on if P3PCR = "1" and P3DDR = "0," but off otherwise.

Figure 6.3 shows a schematic diagram of port 3.

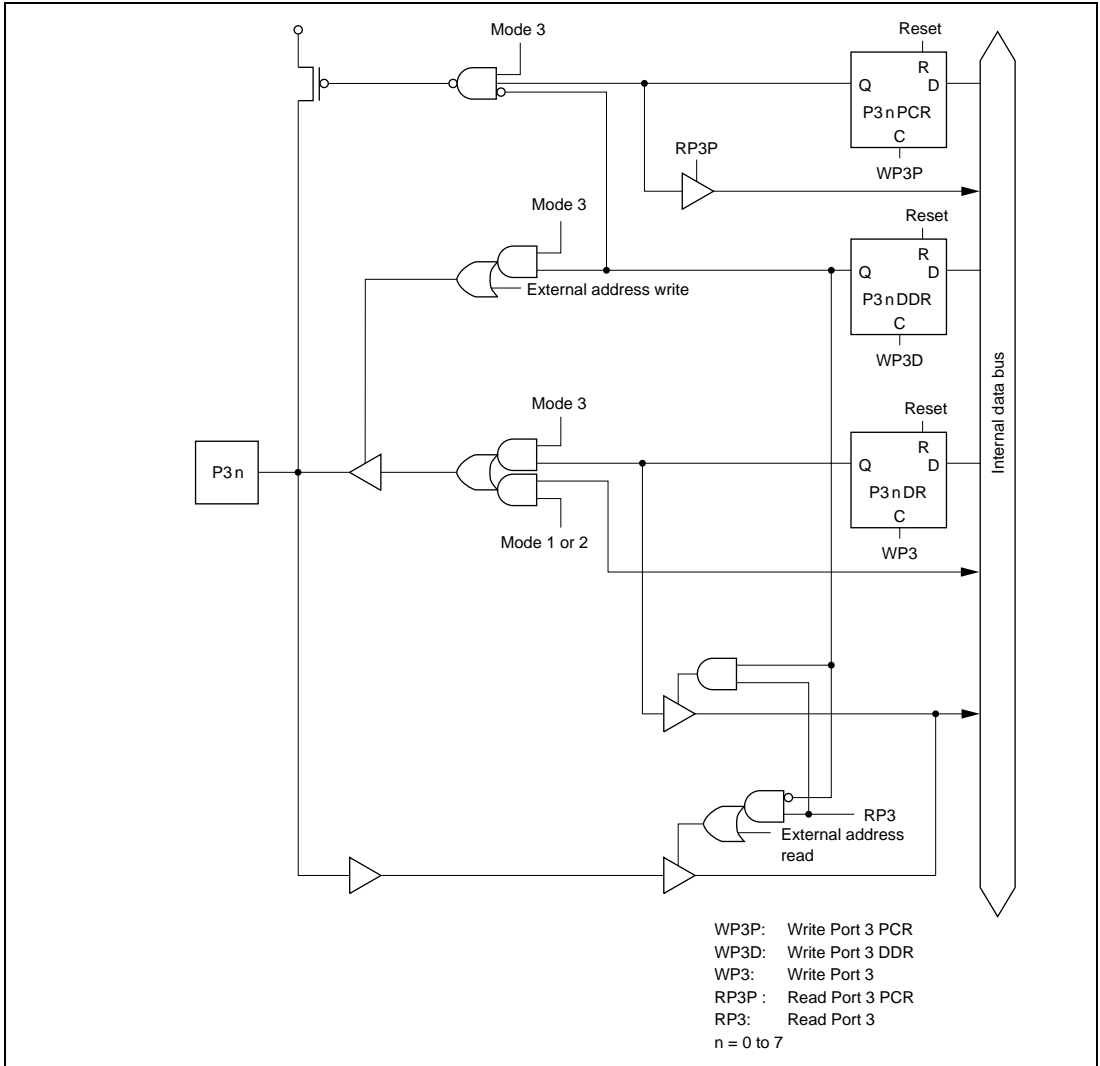

Figure 6.3 Port 3 Schematic Diagram

6.5 Port 4

Port 4 is an 8-bit input/output port that also provides the input and output pins for the 8-bit timers and the output pins for the PWM timers. The pin functions depend on control bits in the control registers of the timers. Pins not used by the timers are available for general-purpose input/output. Table 6.11 lists the pin functions, which are the same in both the expanded and single-chip modes.

Table 6.11 Port 4 Pin Functions (Modes 1 to 3)

Usage	Pin Functions							
I/O port	P4 ₀	P4 ₁	P4 ₂	P4 ₃	P4 ₄	P4 ₅	P4 ₆	P4 ₇
Timer	TMCI ₀	TMO ₀	TMRI ₀	TMCI ₁	TMO ₁	TMRI ₁	PW ₀	PW ₁

See section 7, “8-Bit Timers” and section 8, “PWM Timers,” for details of the timer control bits.

Pins of port 4 can drive a single TTL load and a 90pF capacitive load when they are used as output pins. They can also drive a Darlington pair.

Table 6.12 details the port 4 registers.

Table 6.12 Port 4 Registers

Name	Abbreviation	Read/Write	Initial Value	Address
Port 4 data direction register	P4DDR	W	H'00	H'FFB5
Port 4 data register	P4DR	R/W	H'00	H'FFB7

Port 4 Data Direction Register (P4DDR)—H'FFB5

Bit:	7	6	5	4	3	2	1	0
	P4 ₇ DDR	P4 ₆ DDR	P4 ₅ DDR	P4 ₄ DDR	P4 ₃ DDR	P4 ₂ DDR	P4 ₁ DDR	P4 ₀ DDR
Initial value:	0	0	0	0	0	0	0	0
Read/Write:	W	W	W	W	W	W	W	W

P4DDR is an 8-bit register that selects the direction of each pin in port 4. A pin functions as an output pin if the corresponding bit in P4DDR is set to “1,” and as an input pin if the bit is cleared to “0.”

Port 4 Data Register (P4DR)—H'FFB7

Bit:	7	6	5	4	3	2	1	0
	P4 ₇	P4 ₆	P4 ₅	P4 ₄	P4 ₃	P4 ₂	P4 ₁	P4 ₀
Initial value:	0	0	0	0	0	0	0	0
Read/Write:	R/W	R/W	R/W	R/W	R/W	R/W	R/W	R/W

P4DR is an 8-bit register containing the data for pins P4₇ to P4₀. When the CPU reads P4DR, for output pins (P4DDR = “1”) it reads the value in the P4DR latch, but for input pins (P4DDR = “0”), it obtains the logic level directly from the pin, bypassing the P4DR latch. This also applies to pins used for timer input or output.

Pins P4₀, P4₂, P4₃, and P4₅: As indicated in table 6.11, these pins can be used for general-purpose input or output, or input of 8-bit timer clock and reset signals. When a pin is used for timer signal input, its P4DDR bit should normally be cleared to “0;” otherwise the timer will receive the value in P4DR.

Pins P4₁, P4₄, P4₆, and P4₇: As indicated in table 6.11, these pins can be used for general-purpose input or output, or for 8-bit timer output (P4₁ and P4₄) or PWM timer output (P4₆ and P4₇). Pins used for timer output are unaffected by the values in P4DDR and P4DR.

Reset and Hardware Standby Mode: A reset or entry to the hardware standby mode clears P4DDR and P4DR to all “0” and makes all pins into input port pins.

Software Standby Mode: In the software standby mode, the control registers of the 8-bit and PWM timers are initialized but P4DDR and P4DR remain in their previous states. All pins become input or output port pins depending on the setting of P4DDR. Output pins output the values in P4DR.

Figures 6.4 (a) and 6.4 (b) show schematic diagrams of port 4.

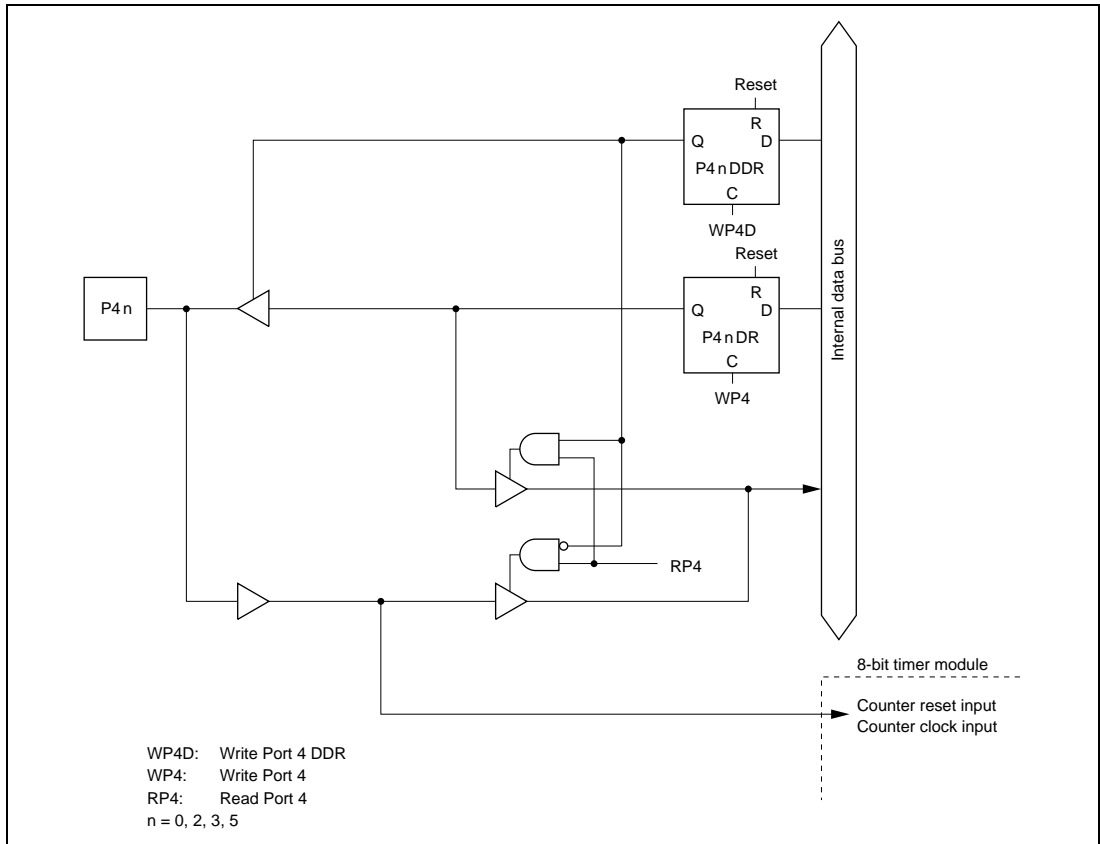

Figure 6.4 (a) Port 4 Schematic Diagram (Pins P4₀, P4₂, P4₃, and P4₅)

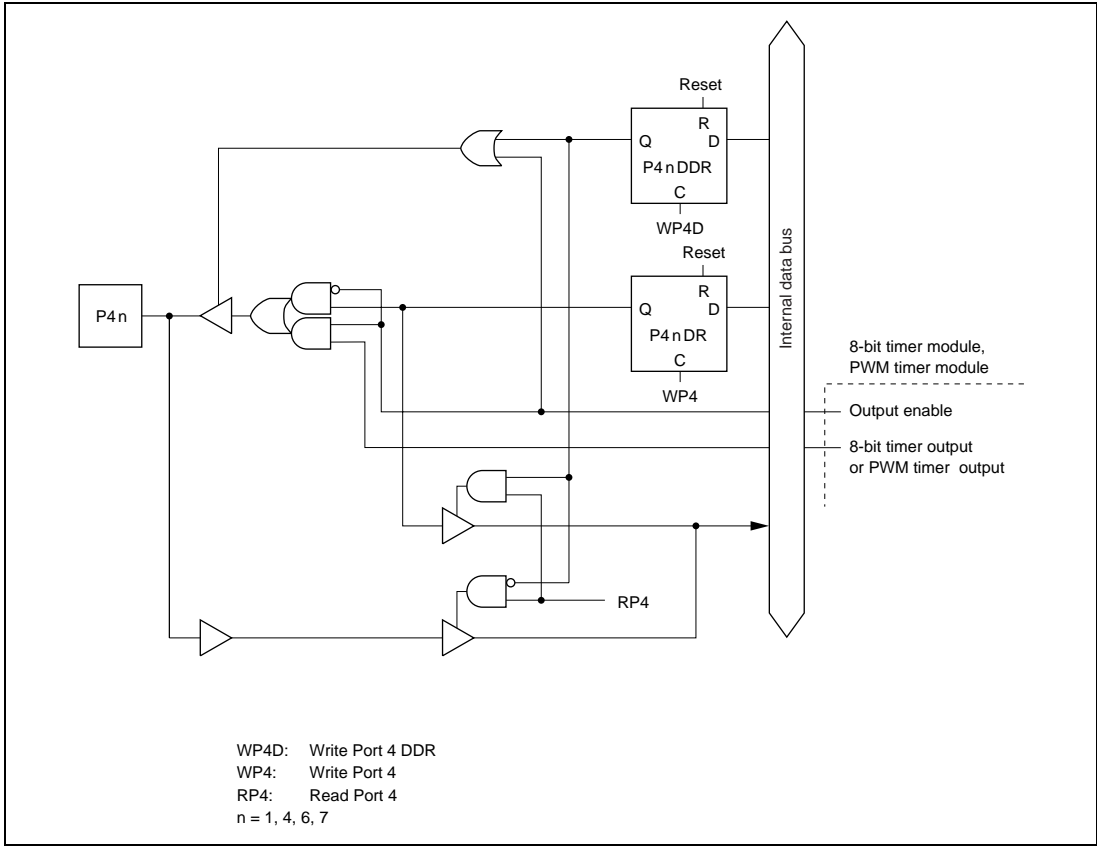

Figure 6.4 (b) Port 4 Schematic Diagram (Pins P4₁, P4₄, P4₆, and P4₇)

6.6 Port 5

Port 5 is a 3-bit input/output port that also provides the input and output pins for serial communication interface 0 (SCI0). The pin functions depend on control bits in the serial control register (SCR). Pins not used for serial communication are available for general-purpose input/output. Table 6.13 lists the pin functions, which are the same in both the expanded and single-chip modes.

Table 6.13 Port 5 Pin Functions (Modes 1 to 3)

Usage	Pin Functions		
I/O port	P5 ₀	P5 ₁	P5 ₂
Serial communication interface 0	TxD ₀	RxD ₀	SCK ₀

See section 9, “Serial Communication Interface,” for details of the serial control bits. Pins used by the serial communication interface are switched between input and output without regard to the values in the data direction register.

Pins of port 5 can drive a single TTL load and a 30pF capacitive load when they are used as output pins. They can also drive a Darlington pair.

Table 6.14 details the port 5 registers.

Table 6.14 Port 5 Registers

Name	Abbreviation	Read/Write	Initial Value	Address
Port 5 data direction register	P5DDR	W	H'F8	H'FFB8
Port 5 data register	P5DR	R/W	H'F8	H'FFBA

Port 5 Data Direction Register (P5DDR)—H'FFB8

Bit:	7	6	5	4	3	2	1	0
	—	—	—	—	—	P5 ₂ DDR	P5 ₁ DDR	P5 ₀ DDR
Initial value:	1	1	1	1	1	0	0	0
Read/Write:	—	—	—	—	—	W	W	W

P5DDR is an 8-bit register that selects the direction of each pin in port 5. A pin functions as an output pin if the corresponding bit in P5DDR is set to “1,” and as an input pin if the bit is cleared to “0.”

Port 5 Data Register (P5DR)—H'FFBA

Bit:	7	6	5	4	3	2	1	0
	—	—	—	—	—	P5 ₂	P5 ₁	P5 ₀
Initial value:	1	1	1	1	1	0	0	0
Read/Write:	—	—	—	—	—	R/W	R/W	R/W

P5DR is an 8-bit register containing the data for pins P5₂ to P5₀. When the CPU reads P5DR, for output pins (P5DDR = “1”) it reads the value in the P5DR latch, but for input pins (P5DDR = “0”), it obtains the logic level directly from the pin, bypassing the P5DR latch. This also applies to pins used for serial communication.

Pin P5₀: This pin can be used for general-purpose input or output, or for output of serial transmit data (TxD₀). When used for TxD₀ output, this pin is unaffected by the values in P5DDR and P5DR.

Pin P5₁: This pin can be used for general-purpose input or output, or for input of serial receive data (RxD₀). When used for RxD₀ input, this pin is unaffected by P5DDR and P5DR.

Pin P5₂: This pin can be used for general-purpose input or output, or for serial clock input or output (SCK₀). When used for SCK₀ input or output, this pin is unaffected by P5DDR and P5DR.

Reset and Hardware Standby Mode: A reset or entry to the hardware standby mode makes all pins of port 5 into input port pins.

Software Standby Mode: In the software standby mode, the serial control register is initialized but P5DDR and P5DR remain in their previous states. All pins become input or output port pins depending on the setting of P5DDR. Output pins output the values in P5DR.

Figures 6.5 (a) to 6.5 (c) show schematic diagrams of port 5.

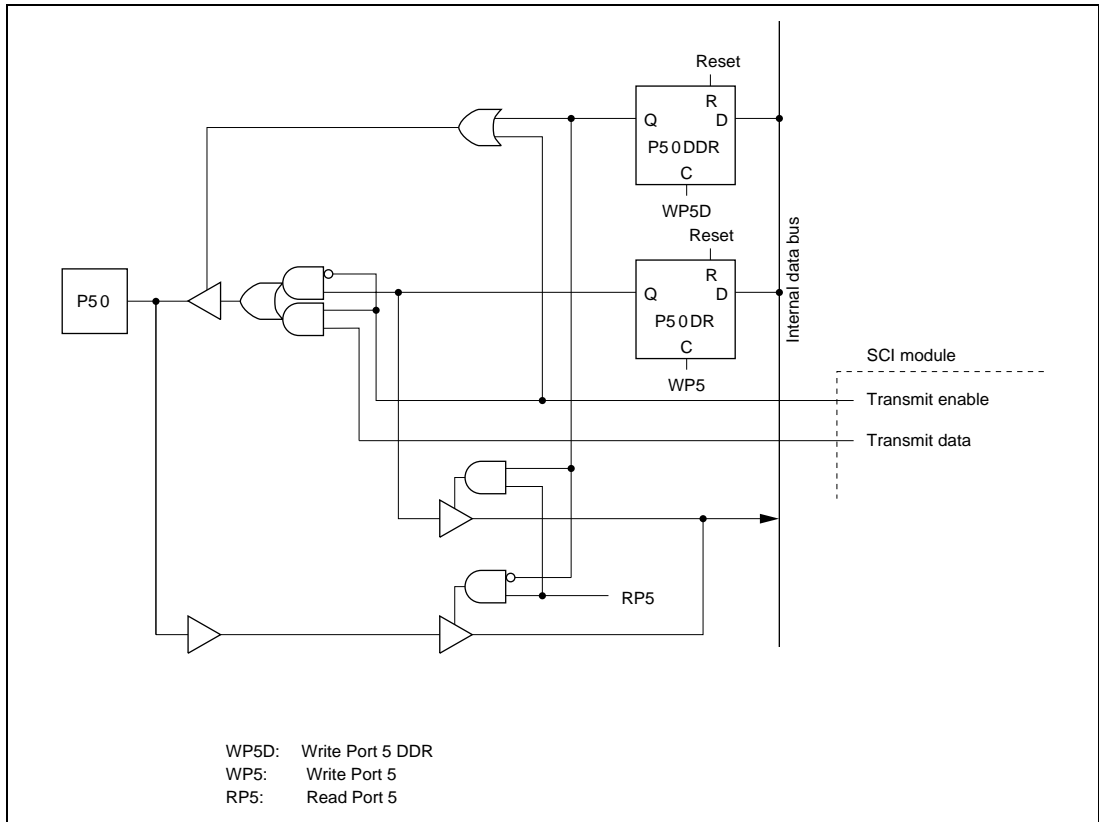

Figure 6.5 (a) Port 5 Schematic Diagram (Pin P50)

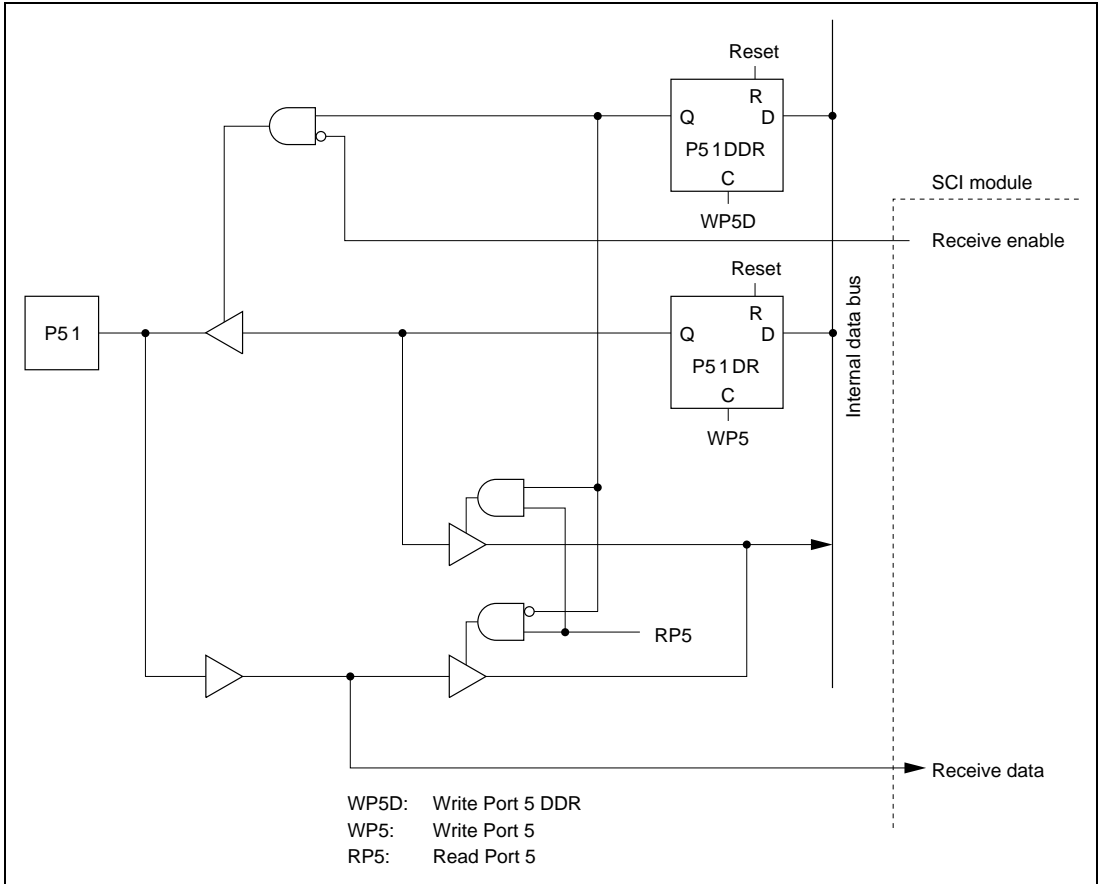

Figure 6.5 (b) Port 5 Schematic Diagram (Pin P5₁)

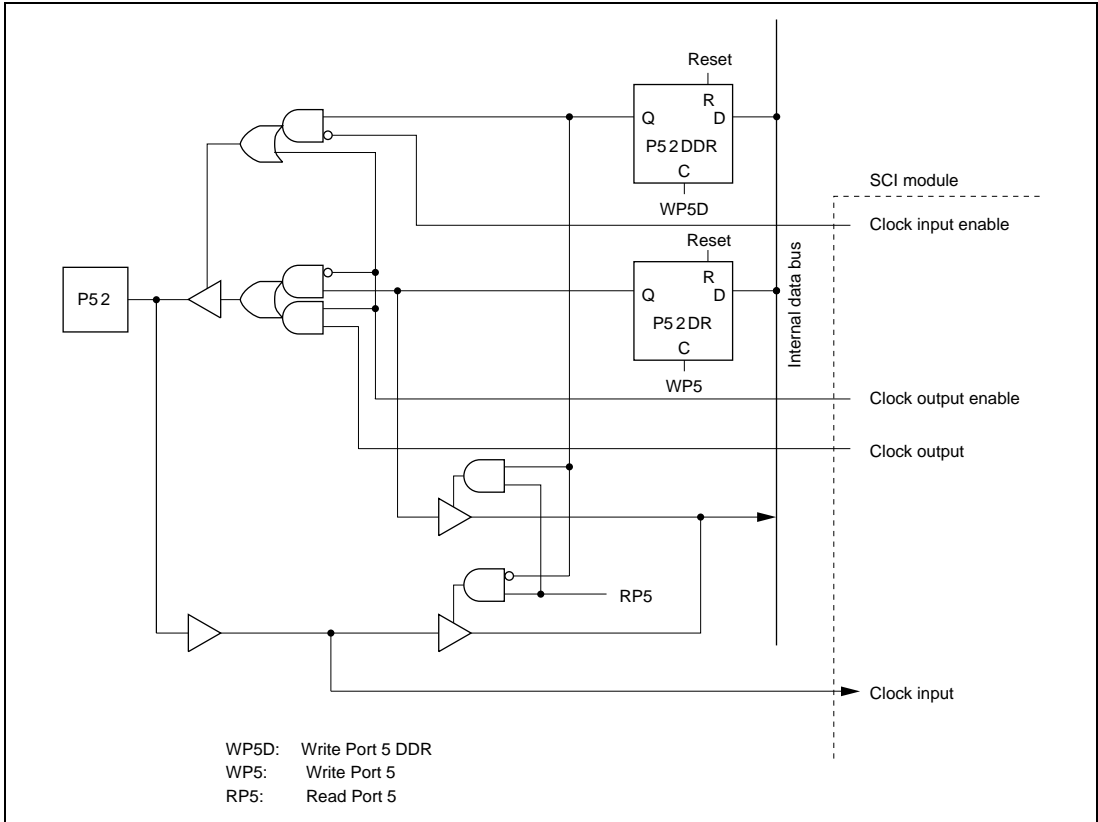

Figure 6.5 (c) Port 5 Schematic Diagram (Pin P5₂)

6.7 Port 6

Port 6 is an 8-bit input/output port that also provides the input and output pins for the free-running timer and the $\overline{\text{IRQ}}_6$ and $\overline{\text{IRQ}}_7$ input/output pins. The pin functions depend on control bits in the free-running timer control registers, and on bit 6 or 7 of the interrupt enable register. Pins not used for timer or interrupt functions are available for general-purpose input/output. Table 6.15 lists the pin functions, which are the same in both the expanded and single-chip modes.

Table 6.15 Port 6 Pin Functions

Usage	Pin Functions (Modes 1 to 3)							
I/O port	P6 ₀	P6 ₁	P6 ₂	P6 ₃	P6 ₄	P6 ₅	P6 ₆	P6 ₇
Timer/interrupt	FTCI	FTOA	FTIA	FTIB	FTIC	FTID	FTOB/ $\overline{\text{IRQ}}_6$	$\overline{\text{IRQ}}_7$

See section 4 “Exception Handling” and section 6, “16-Bit Free-Running Timer” for details of the free-running timer and interrupts.

Pins of port 6 can drive a single TTL load and a 90pF capacitive load when they are used as output pins. They can also drive a Darlington pair.

Table 6.16 details the port 6 registers.

Table 6.16 Port 6 Registers

Name	Abbreviation	Read/Write	Initial Value	Address
Port 6 data direction register	P6DDR	W	H'00	H'FFB9
Port 6 data register	P6DR	R/W	H'00	H'FFBB

Port 6 Data Direction Register (P6DDR)—H'FFB9

Bit:	7	6	5	4	3	2	1	0
	P6 ₇ DDR	P6 ₆ DDR	P6 ₅ DDR	P6 ₄ DDR	P6 ₃ DDR	P6 ₂ DDR	P6 ₁ DDR	P6 ₀ DDR
Initial value:	0	0	0	0	0	0	0	0
Read/Write:	W	W	W	W	W	W	W	W

P6DDR is an 8-bit register that selects the direction of each pin in port 6. A pin functions as an output pin if the corresponding bit in P6DDR is set to “1,” and as an input pin if the bit is cleared to “0.”

Port 6 Data Register (P6DR)—H'FFBB

Bit:	7	6	5	4	3	2	1	0
	P6 ₇	P6 ₆	P6 ₅	P6 ₄	P6 ₃	P6 ₂	P6 ₁	P6 ₀
Initial value:	0	0	0	0	0	0	0	0
Read/Write:	R/W	R/W	R/W	R/W	R/W	R/W	R/W	R/W

P6DR is an 8-bit register containing the data for pins P6₇ to P6₀. When the CPU reads P6DR, for output pins (P6DDR = “1”) it reads the value in the P6DR latch, but for input pins (P6DDR = “0”), it obtains the logic level directly from the pin, bypassing the P6DR latch. This also applies to pins used for input and output of timer and interrupt signals.

Pins P6₀, P6₂, P6₃, P6₄ and P6₅: As indicated in table 6.15, these pins can be used for general-purpose input or output, or for input of free-running timer clock and input capture signals. When a pin is used for free-running timer input, its P6DDR bit should be cleared to “0;” otherwise the free-running timer will receive the value in P6DR.

Pin P6₁: This pin can be used for general-purpose input or output, or for the output compare A signal (FTOA) of the free-running timer. When used for FTOA output, this pin is unaffected by the values in P6DDR and P6DR.

Pin P6₆: This pin can be used for general-purpose input or output, for the output compare B signal (FTOB) of the free-running timer, or for IRQ₆ input. When used for FTOB output, this pin is unaffected by the values in P6DDR and P6DR. When this pin is used for IRQ₆ input, P6₆DDR should normally be cleared to “0;” so that the value in P6DR will not generate interrupts.

Pin P6₇: This pin can be used for general-purpose input or output, or IRQ₇ input. When it is used for IRQ₇ input, P6₇DDR should normally be cleared to “0;” so that the value in P6DR will not generate interrupts.

Reset and Hardware Standby Mode: A reset or entry to the hardware standby mode clears P6DDR and P6DR to all “0” and makes all pins into input port pins.

Software Standby Mode: In the software standby mode, the free-running timer control registers are initialized but P6DDR and P6DR remain in their previous states. All pins become input or output port pins depending on the setting of P6DDR. Output pins output the values in P6DR.

Figures 6.6 (a) to 6.6 (d) shows schematic diagrams of port 6.

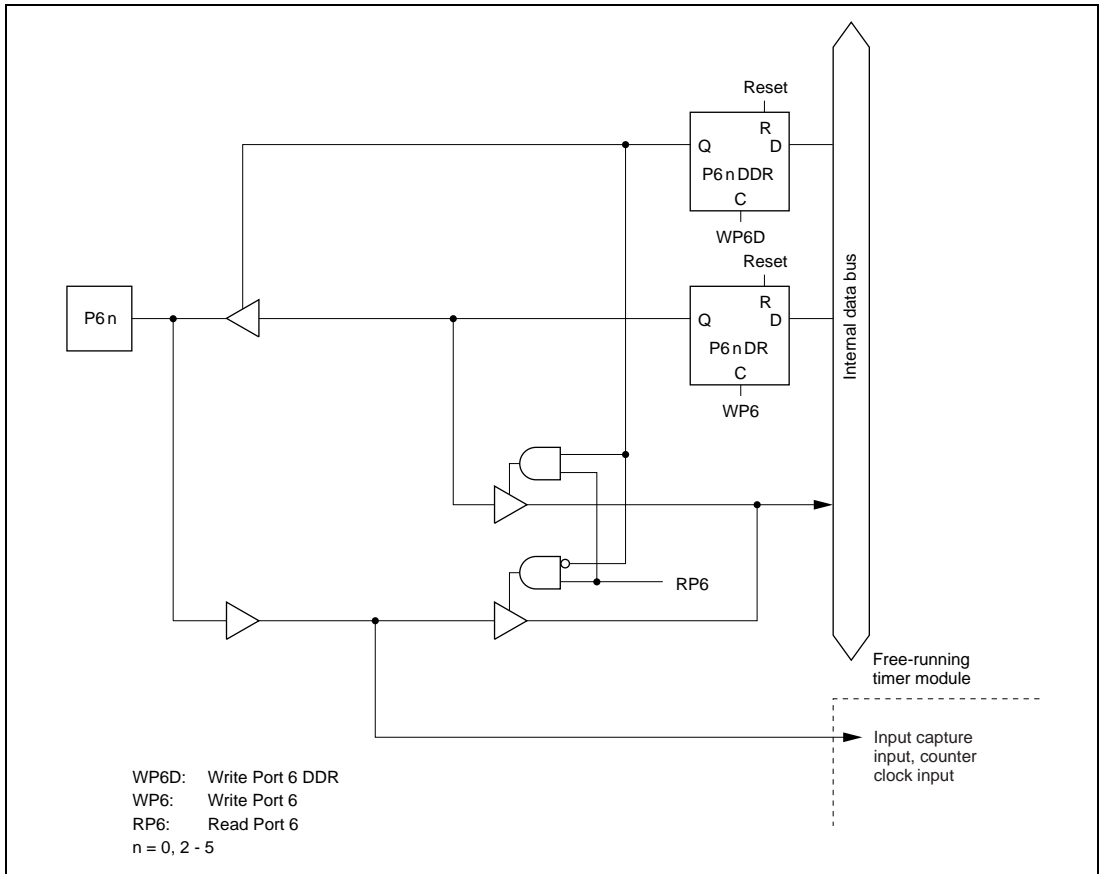

Figure 6.6 (a) Port 6 Schematic Diagram (Pins $P6_0$, $P6_2$, $P6_3$, $P6_4$, and $P6_5$)

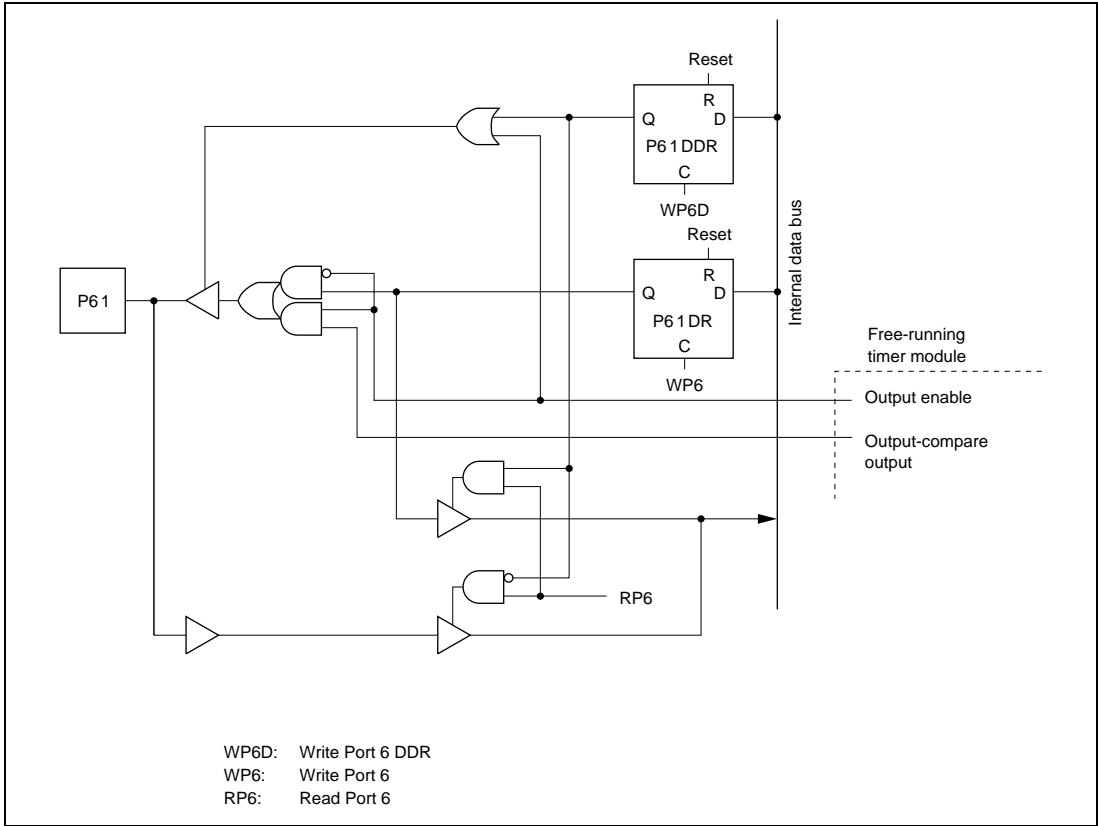

Figure 6.6 (b) Port 6 Schematic Diagram (Pin P6₁)

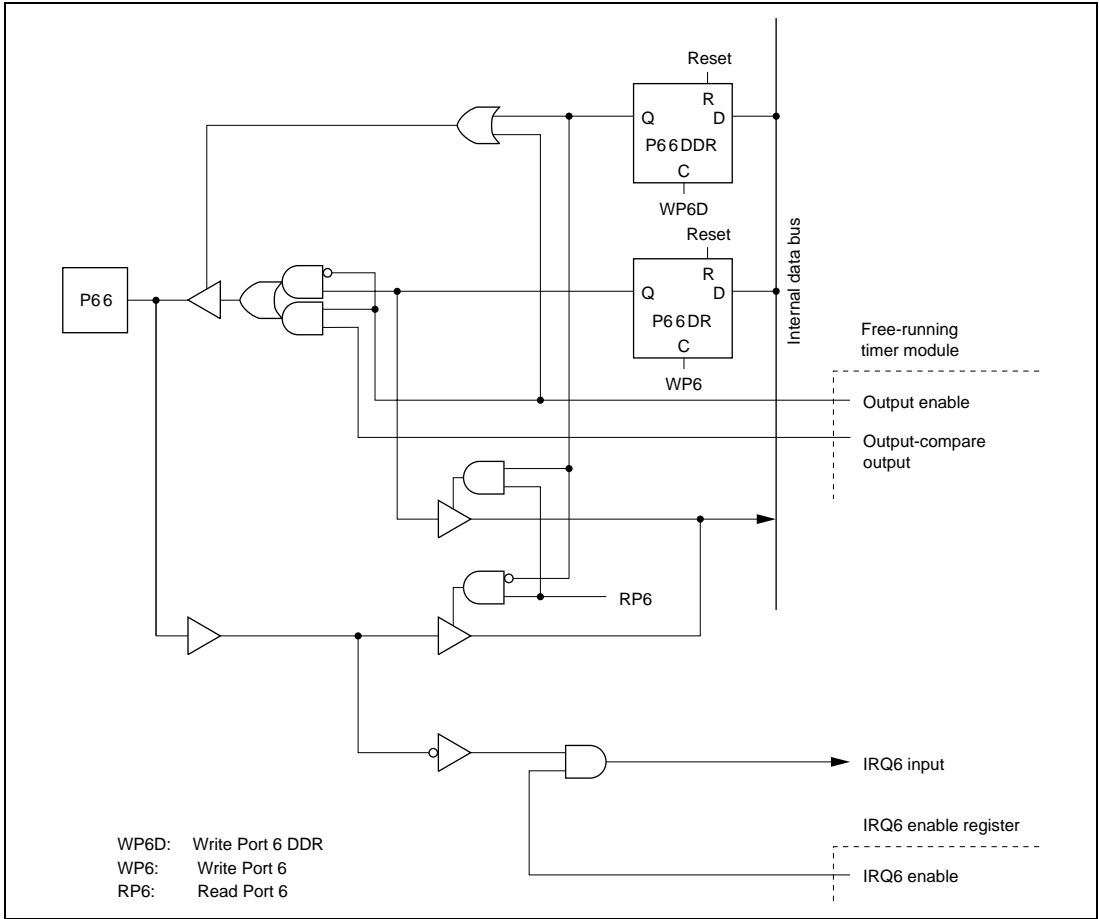

Figure 6.6 (c) Port 6 Schematic Diagram (Pin P6₆)

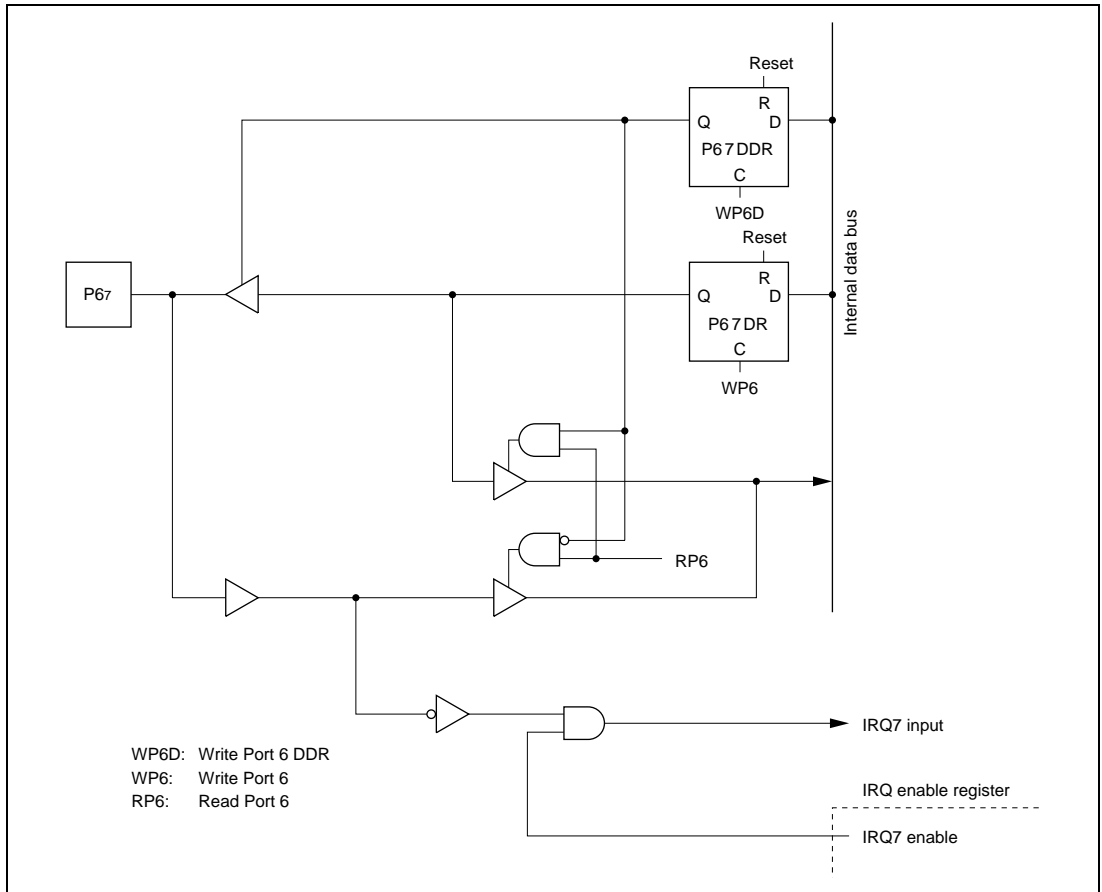

Figure 6.6 (d) Port 6 Schematic Diagram (Pin P67)

6.8 Port 7

Port 7 is an 8-bit input port that also provides the analog input pins for the A/D converter module, and analog output pins for the D/A converter module. The pin functions are the same in both the expanded and single-chip modes.

Table 6.17 lists the pin functions. Table 6.18 describes the port 7 data register, which simply consists of connections of the port 7 pins to the internal data bus. Figure 6.7 (a) and 6.7 (b) show schematic diagrams of port 7.

Table 6.17 Port 7 Pin Functions (Modes 1 to 3)

Usage	Pin Functions							
I/O port	P7 ₀	P7 ₁	P7 ₂	P7 ₃	P7 ₄	P7 ₅	P7 ₆	P7 ₇
Analog input	AN ₀	AN ₁	AN ₂	AN ₃	AN ₄	AN ₅	AN ₆	AN ₇
Analog output	—	—	—	—	—	—	DA ₀	DA ₁

Table 6.18 Port 7 Register

Name	Abbreviation	Read/Write	Initial Value	Address
Port 7 data register	P7DR	R	Undetermined	H'FFBE

Port 7 Data Register (P7DR)—H'FFBE

Bit:	7	6	5	4	3	2	1	0
	P7 ₇	P7 ₆	P7 ₅	P7 ₄	P7 ₃	P7 ₂	P7 ₁	P7 ₀
Initial value:	*	*	*	*	*	*	*	*
Read/Write:	R	R	R	R	R	R	R	R

Note: Depends on the levels of pins P7₇ to P7₀.

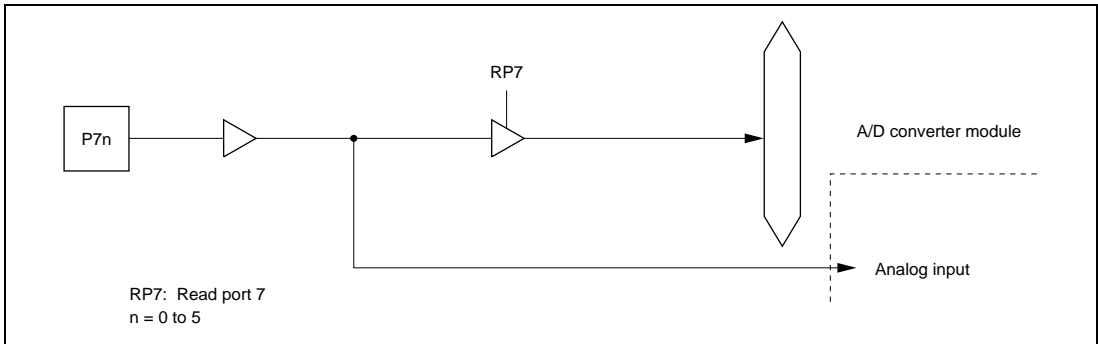

Figure 6.7 (a) Port 7 Schematic Diagram (Pins $P7_0$ to $P7_5$)

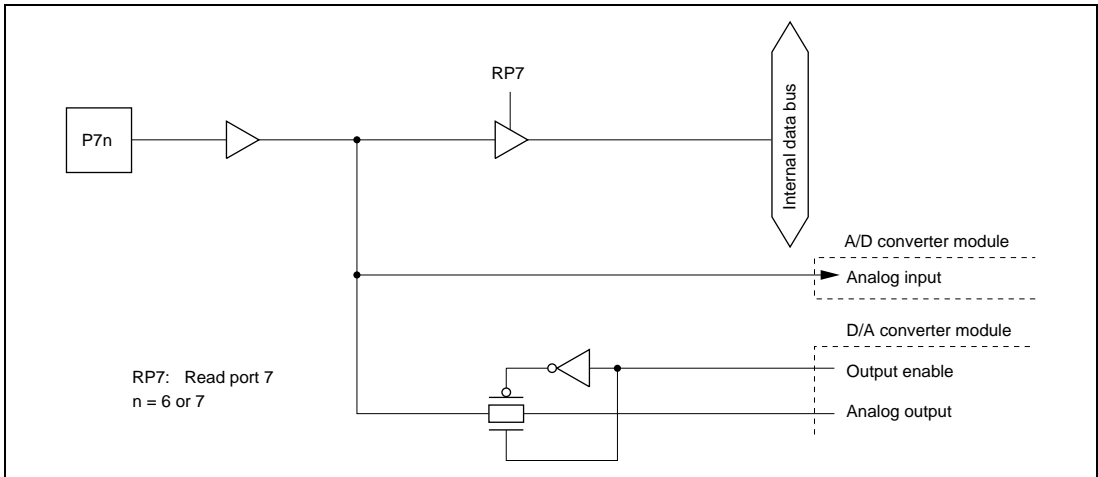

Figure 6.7 (b) Port 7 Schematic Diagram (Pins $P7_6$ and $P7_7$)

6.9 Port 8

Port 8 is a 7-bit input/output port that also provides pins for interrupt input and serial communication. Table 6.19 lists the pin functions.

Table 6.19 Port 8 Pin Functions

Pin	I/O Port	Serial Communication	Interrupt Input
P8 ₀	Input/output	—	—
P8 ₁	Input/output	—	—
P8 ₂	Input/output	—	—
P8 ₃	Input/output	—	—
P8 ₄	Input/output	TxD ₁ output	$\overline{\text{IRQ}}_3$ input
P8 ₅	Input/output	RxD ₁ input	$\overline{\text{IRQ}}_4$ input
P8 ₆	Input/output	SCK ₁ input/output	$\overline{\text{IRQ}}_5$ input

Pins of port 8 can drive a single TTL load and a 30pF capacitive load when they are used as output pins. They can also drive a Darlington pair.

Table 6.20 details the port 8 registers.

Table 6.20 Port 8 Registers

Name	Abbreviation	Read/Write	Initial Value	Address
Port 8 data direction register	P8DDR	W	H'80	H'FFBD
Port 8 data register	P8DR	R/W	H'80	H'FFBF

Port 8 Data Direction Register (P8DDR)—H'FFBD

Bit:	7	6	5	4	3	2	1	0
	—	P8 ₆ DDR	P8 ₅ DDR	P8 ₄ DDR	P8 ₃ DDR	P8 ₂ DDR	P8 ₁ DDR	P8 ₀ DDR
Initial value:	1	0	0	0	0	0	0	0
Read/Write:	—	W	W	W	W	W	W	W

P8DDR is an 8-bit register that selects the direction of each pin in port 8. A pin functions as an output pin if the corresponding bit in P8DDR is set to “1,” and as an input pin if the bit is cleared to “0.”

Bit 7 is reserved. It cannot be modified, and is always read as “1.”

Port 8 Data Register (P8DR)—H'FFBF

Bit:	7	6	5	4	3	2	1	0
	—	P8 ₆	P8 ₅	P8 ₄	P8 ₃	P8 ₂	P8 ₁	P8 ₀
Initial value:	1	0	0	0	0	0	0	0
Read/Write:	—	R/W	R/W	R/W	R/W	R/W	R/W	R/W

P8DR is an 8-bit register containing the data for pins P8₆ to P8₀. When the CPU reads P8DR, for output pins (P8DDR = “1”) it reads the value in the P8DR latch, but for input pins (P8DDR = “0”), it obtains the logic level directly from the pin, bypassing the P8DR latch. This also applies to pins used for interrupt input and serial communication.

Bit 7 is reserved. It cannot be modified, and is always read as “1.”

Pins 8₀ to P8₃: These pins are available for general-purpose input or output.

Pin P8₄: This pin has the same functions in all modes. It can be used for general-purpose input or output, for output of serial transmit data (TxD₁), or for IRQ₃ input. When used for TxD₁ output, this pin is unaffected by the values in P8DDR and P8DR. When this pin is used for IRQ₃ input, P8₄DDR should normally be cleared to “0,” so that the value in P8DR will not generate interrupts.

Pin P8₅: This pin has the same functions in all modes. It can be used for general-purpose input or output, for input of serial receive data (RxD₁), or for IRQ₄ input. When used for RxD₁ input, this pin is unaffected by the values in P8DDR and P8DR. When this pin is used for IRQ₄ input, P8₅DDR should normally be cleared to “0,” so that the value in P8DR will not generate interrupts.

Pin P8₆: This pin has the same functions in all modes. It can be used for general-purpose input or output, for serial clock input or output (SCK₁), or for IRQ₅ input. When this pin is used for IRQ₅ input, P8₆DDR should normally be cleared to “0,” so that the value in P8DR will not generate interrupts.

When used for SCK₁ input or output, this pin is unaffected by the values in P8DDR and P8DR.

Reset: A reset clears bits P8₆DDR to P8₀DDR to “0” and clears the serial control bits and interrupt enable bits to “0,” making P8₆ to P8₀ into input port pins.

Hardware Standby Mode: All pins are placed in the high-impedance state.

Software Standby Mode: In the software standby mode, the serial control register is initialized, but the interrupt enable register, P8DDR, and P8DR remain in their previous states. Pins that were being used for serial communication revert to general-purpose input or output, depending on the value in P8DDR. Other pins remain in their previous state. Output pins output the values in P8DR.

Figures 6.8 (a) to 6.8 (d) show schematic diagrams of port 8.

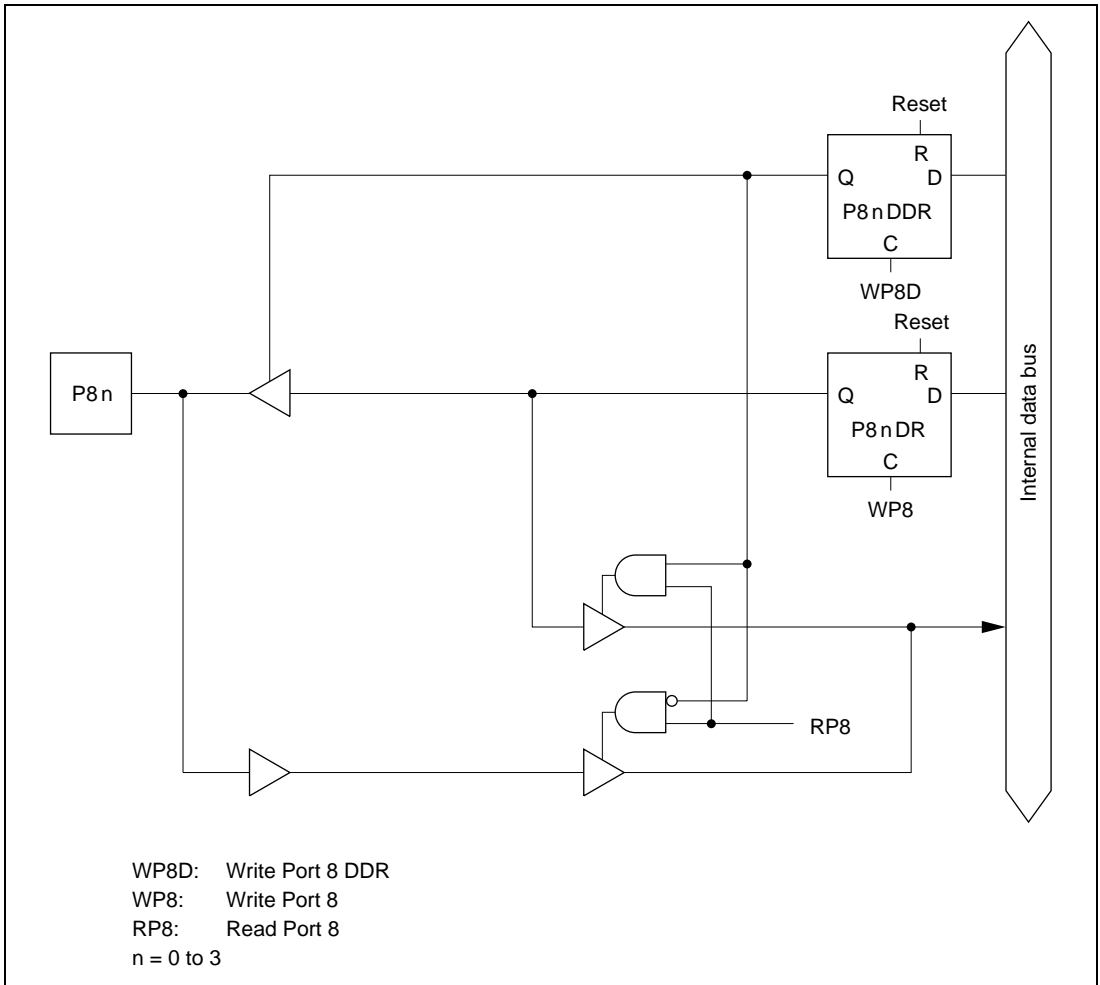

Figure 6.8 (a) Port 8 Schematic Diagram (Pins P8₀ to P8₃)

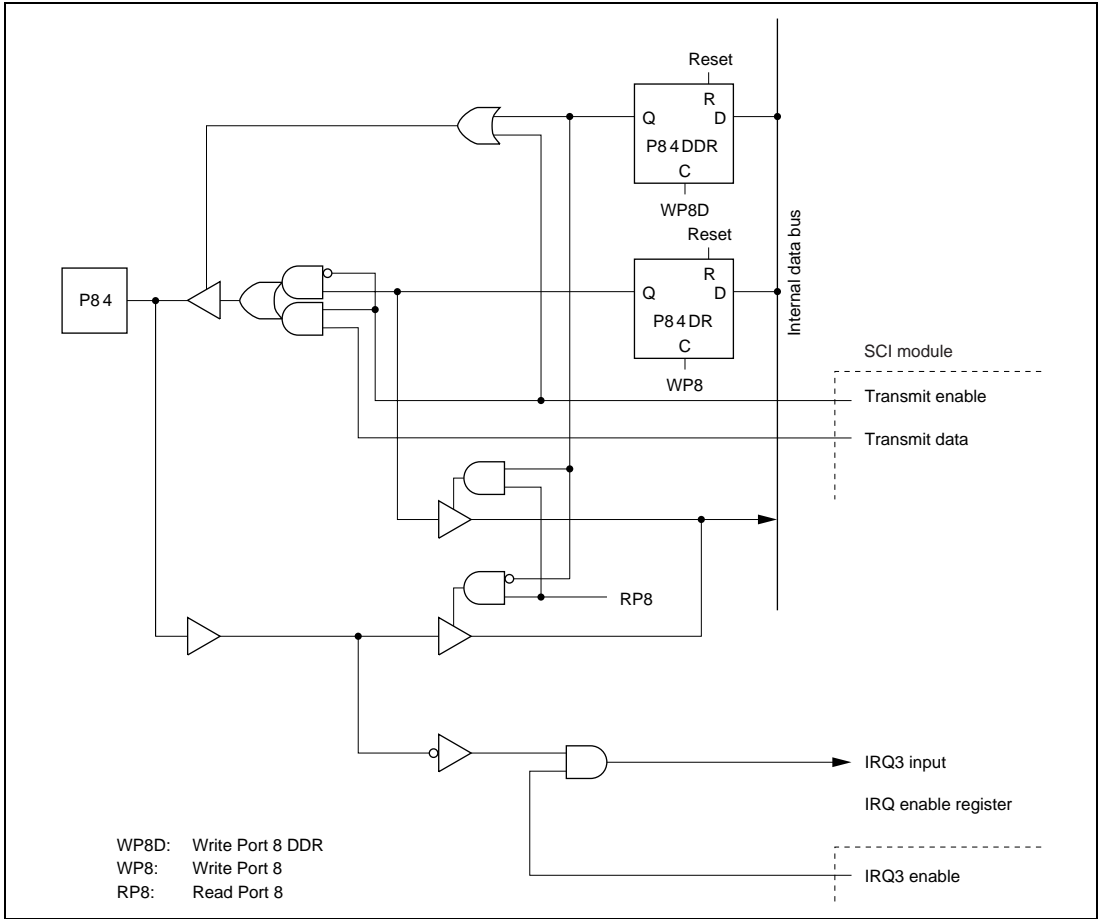

Figure 6.8 (b) Port 8 Schematic Diagram (Pin P8₄)

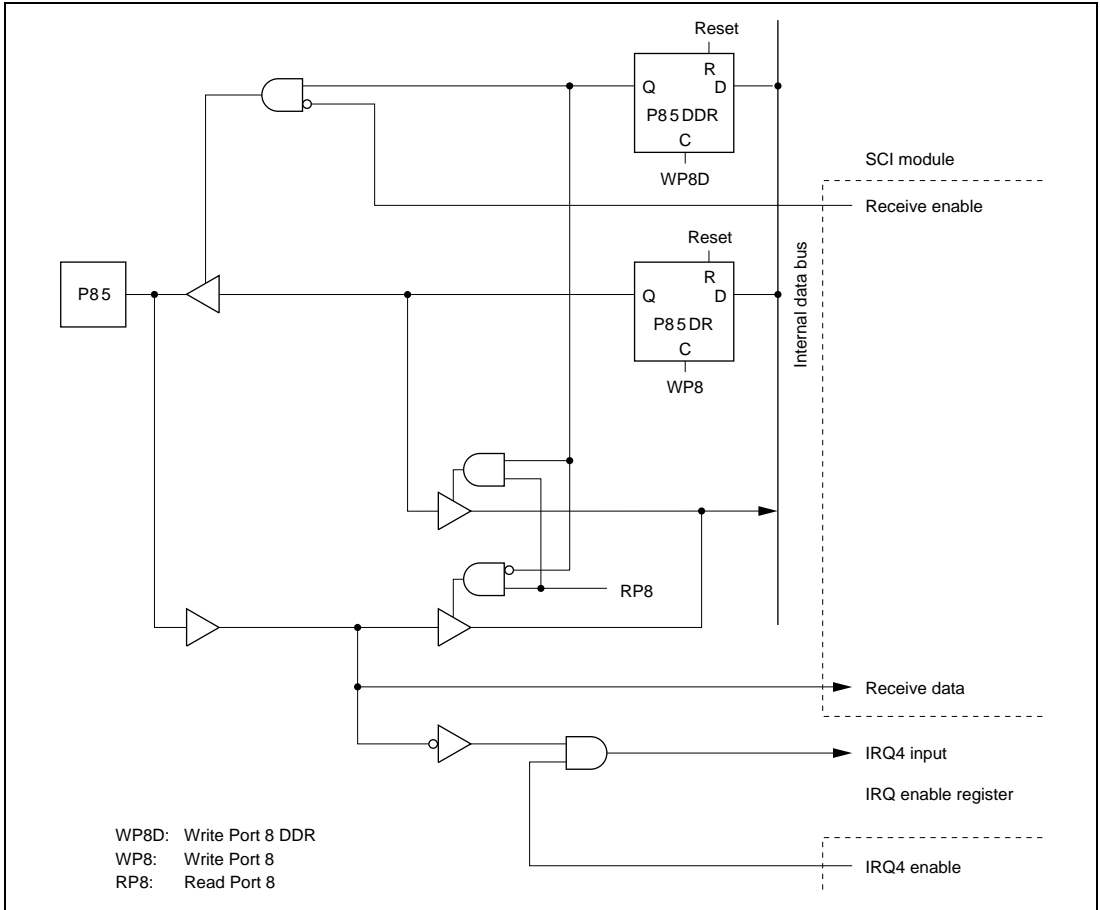

Figure 6.8 (c) Port 8 Schematic Diagram (Pin P8₅)

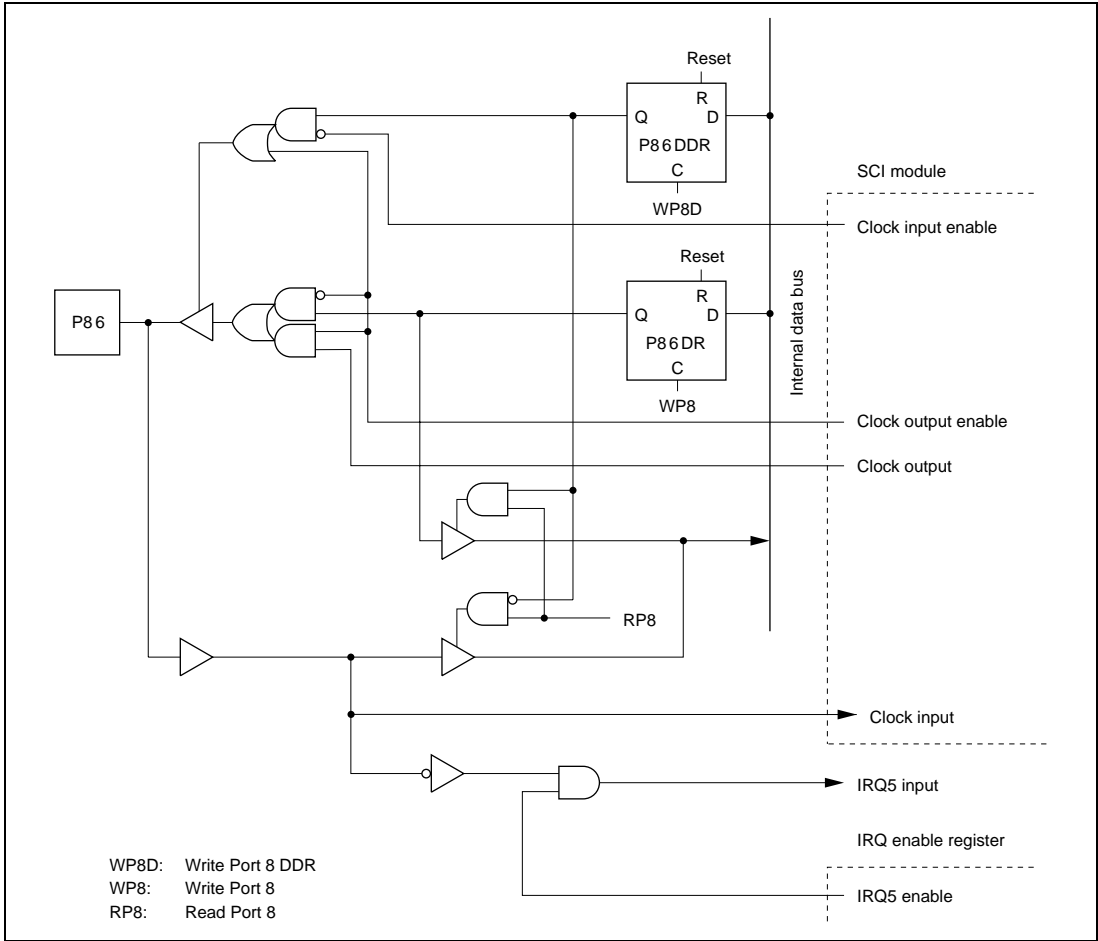

Figure 6.8 (d) Port 8 Schematic Diagram (Pin P8₆)

6.10 Port 9

Port 9 is an 8-bit input/output port that also provides pins for interrupt input (IRQ₀ to IRQ₂), A/D trigger input, system clock (ϕ) output, and bus control signals (in the expanded modes).

Pins P9₇ to P9₃ have different functions in different modes. Pins P9₂ to P9₀ have the same functions in all modes. Table 6.21 lists the pin functions.

Table 6.21 Port 9 Pin Functions

Pin	Expanded Modes	Single-Chip Mode
P9 ₀	P9 ₀ input/output, $\overline{\text{IRQ}}_2$ input, and $\overline{\text{ADTRG}}$ input (simultaneously)	
P9 ₁	P9 ₁ input/output and $\overline{\text{IRQ}}_1$ input (simultaneously)	
P9 ₂	P9 ₂ input/output and $\overline{\text{IRQ}}_0$ input (simultaneously)	
P9 ₃	$\overline{\text{RD}}$ output	P9 ₃ input/output
P9 ₄	$\overline{\text{WR}}$ output	P9 ₄ input/output
P9 ₅	$\overline{\text{AS}}$ output	P9 ₅ input/output
P9 ₆	ϕ output	P9 ₆ input or ϕ output
P9 ₇	$\overline{\text{WAIT}}$ input	P9 ₇ input/output

Pins of port 9 can drive a single TTL load and a 90pF capacitive load when they are used as output pins.

Table 6.22 details the port 9 registers.

Table 6.22 Port 9 Registers

Name	Abbreviation	Read/Write	Initial Value	Address
Port 9 data direction register	P9DDR	W	H'40 (modes 1 and 2) H'00 (mode 3)	H'FFC0
Port 9 data register	P9DR	R/W* ¹	Undetermined* ²	H'FFC1

Notes: 1. Bit 6 is read-only.

2. Bit 6 is undetermined. Other bits are initially "0."

Port 9 Data Direction Register (P9DDR)—H'FFC0

Bit	7	6	5	4	3	2	1	0
	P9 ₇ DDR	P9 ₆ DDR	P9 ₅ DDR	P9 ₄ DDR	P9 ₃ DDR	P9 ₂ DDR	P9 ₁ DDR	P9 ₀ DDR
Modes 1 and 2								
Initial value	0	1	0	0	0	0	0	0
Read/Write	W	—	W	W	W	W	W	W
Mode 3								
Initial value	0	0	0	0	0	0	0	0
Read/Write	W	W	W	W	W	W	W	W

P9DDR is an 8-bit register that selects the direction of each pin in port 9. A pin functions as an output pin if the corresponding bit in P9DDR is set to “1,” and as an input pin if the bit is cleared to “0.”

Port 9 Data Register (P9DR)—H'FFC1

Bit:	7	6	5	4	3	2	1	0
	P9 ₇	P9 ₆	P9 ₅	P9 ₄	P9 ₃	P9 ₂	P9 ₁	P9 ₀
Initial value:	0	*	0	0	0	0	0	0
Read/Write:	R/W	R	R/W	R/W	R/W	R/W	R/W	R/W

Note: Determined by the level at pin P9₆.

P9DR is an 8-bit register containing the data for pins P9₇ to P9₀. When the CPU reads P9DR, for output pins (P9DDR = “1”) it reads the value in the P9DR latch, but for input pins (P9DDR = “0”), it obtains the logic level directly from the pin, bypassing the P9DR latch. This also applies to pins used for interrupt input, A/D trigger input, clock output, and control signal input or output.

Pins P9₀, P9₁, and P9₂: Can be used for general-purpose input or output, interrupt request input, or A/D trigger input. See table 6.21. If a pin is used for interrupt or A/D trigger input, its data direction bit should be cleared to “0,” so that the output from P9DR will not generate an interrupt request or A/D trigger signal.

Pins P9₃, P9₄, and P9₅: In modes 1 and 2 (the expanded modes), these pins are used for output of the RD, WR, and AS bus control signals. They are unaffected by the values in P9DDR and P9DR.

In mode 3 (single-chip mode), these pins can be used for general-purpose input or output.

Pin P9₆: In modes 1 and 2, this pin is used for system clock (ϕ) output.

In mode 3, this pin is used for general-purpose input if P96DDR is cleared to “0,” or system clock output if P9₆DDR is set to “1.”

Pin P9₇: In modes 1 and 2, this pin is used for input of the WAIT bus control signal. It is unaffected by the values in P9DDR and P9DR.

In mode 3 (single-chip mode), this pin can be used for general-purpose input or output.

Reset: In the single-chip mode (mode 3), a reset initializes all pins of port 9 to the general-purpose input function. In the expanded modes (modes 1 and 2), P9₀ to P9₂ are initialized as input port pins, and P9₃ to P9₇ are initialized to their bus control and system clock output functions.

Hardware Standby Mode: All pins are placed in the high-impedance state.

Software Standby Mode: All pins remain in their previous state. For RD, WR, AS, and ϕ this means the High output state.

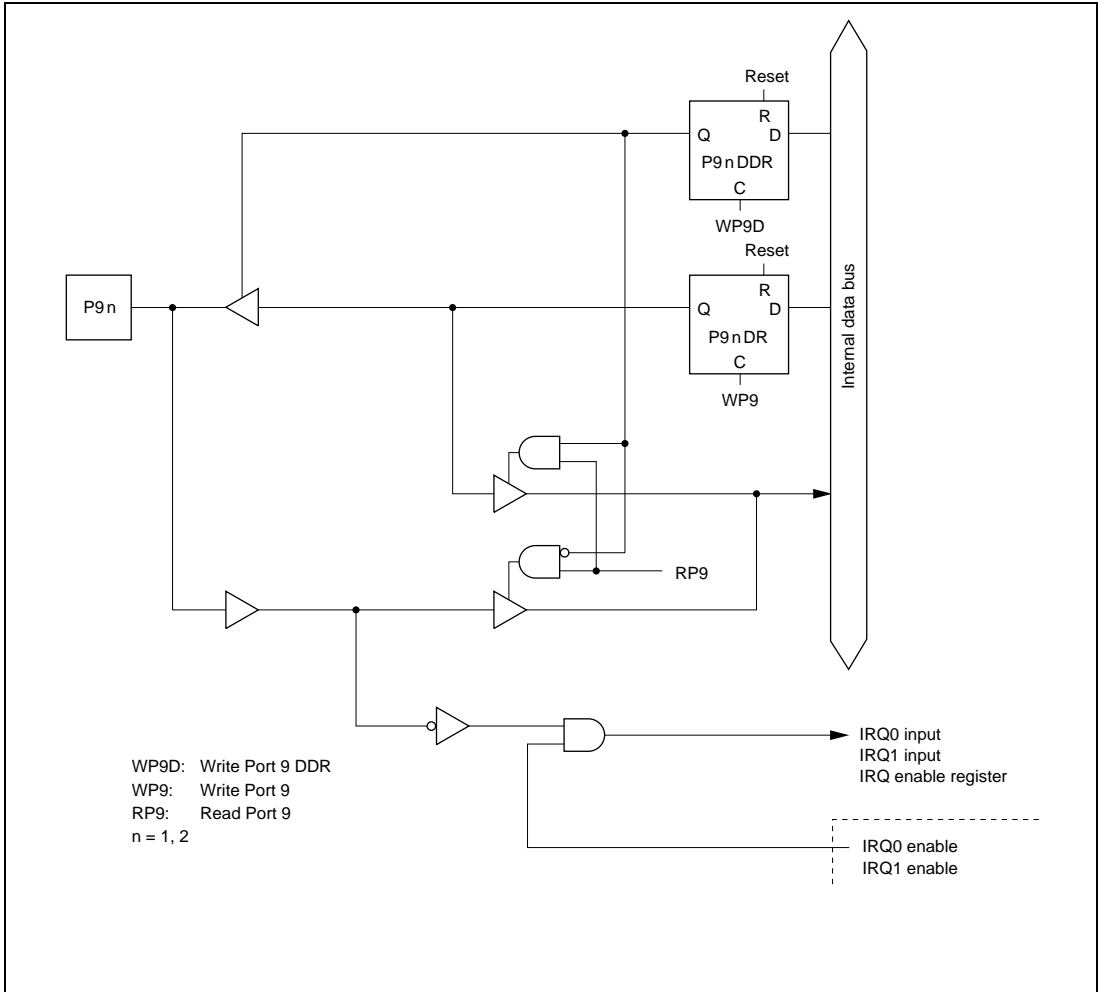

Figure 6.9 (b) Port 9 Schematic Diagram (Pins P9₁ and P9₂)

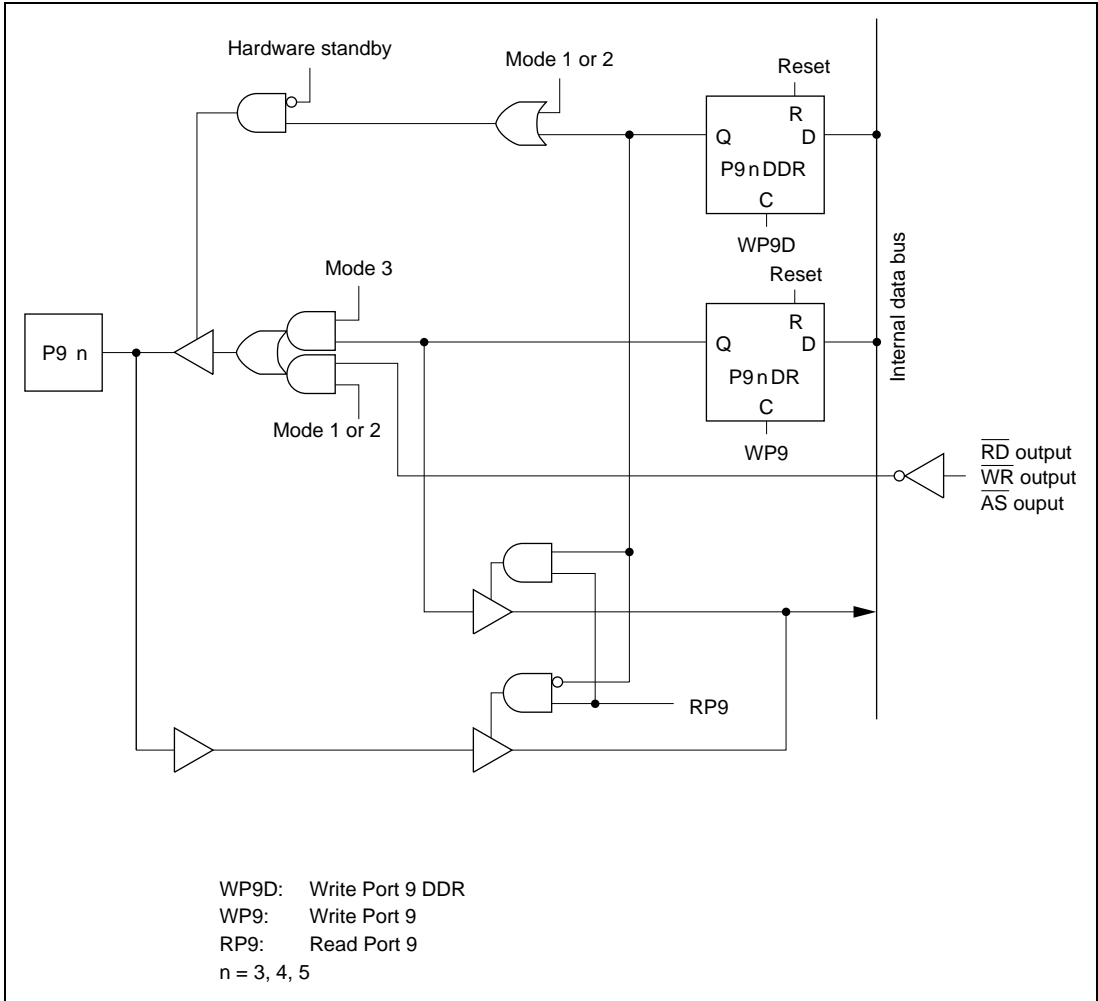

Figure 6.9 (c) Port 9 Schematic Diagram (Pins P9₃, P9₄, and P9₅)

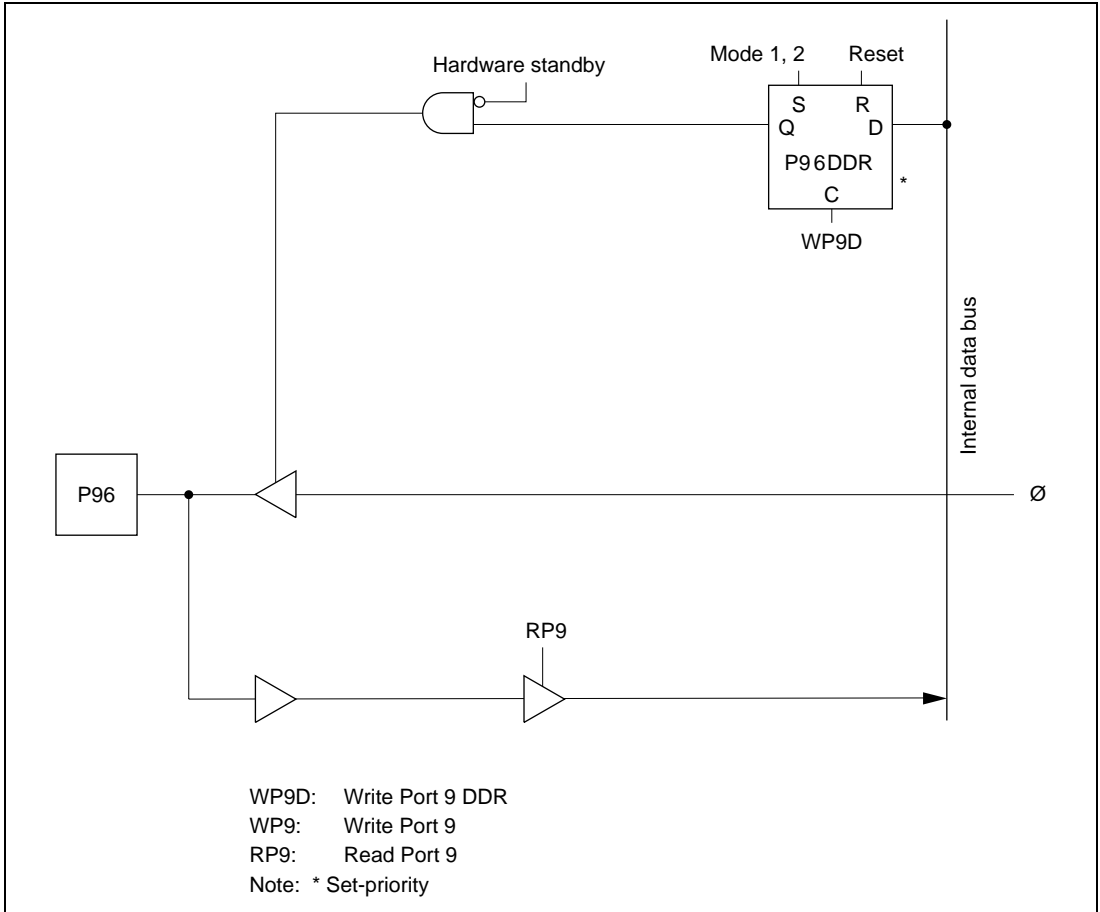

Figure 6.9 (d) Port 9 Schematic Diagram (Pin P9₆)

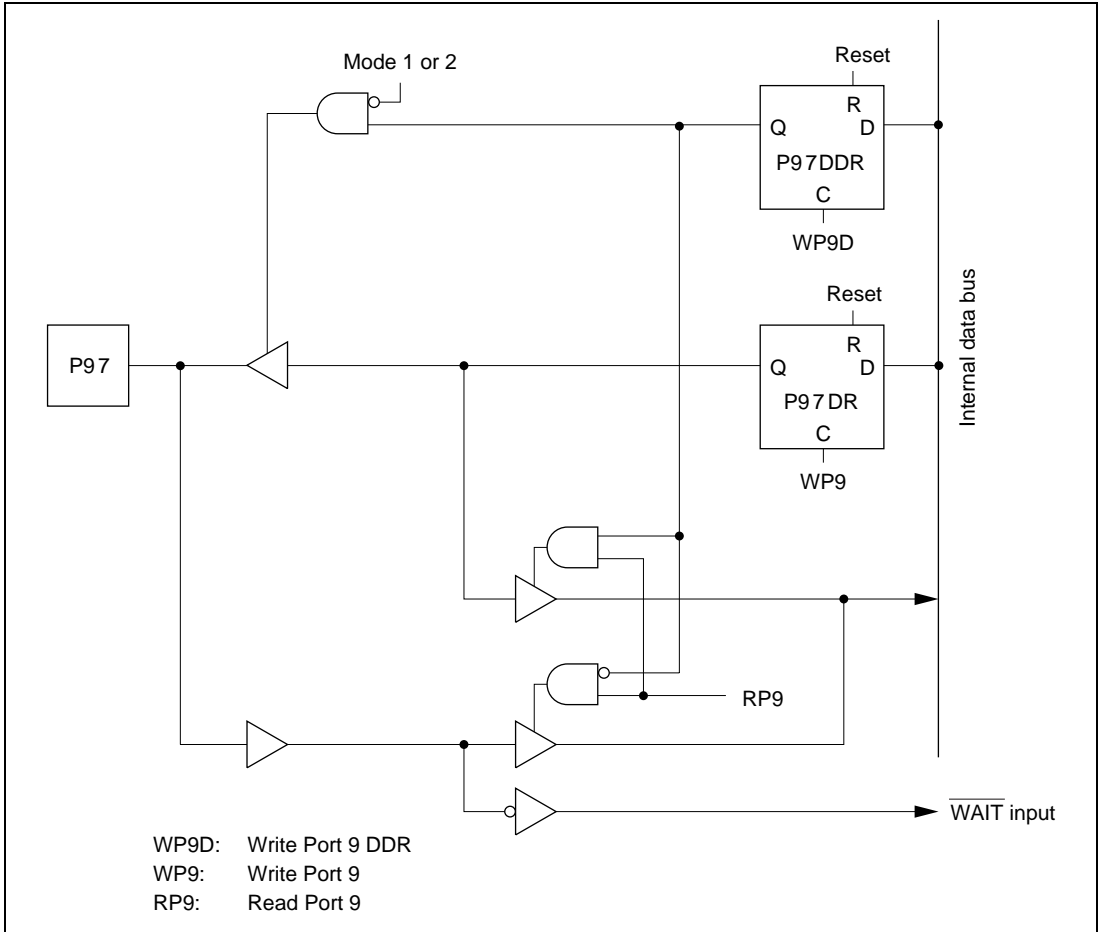

Figure 6.9 (e) Port 9 Schematic Diagram (Pin P97)

Section 7 16-Bit Free-Running Timer

7.1 Overview

The H8/338 Series has an on-chip 16-bit free-running timer (FRT) module that uses a 16-bit free-running counter as a time base. Applications of the FRT module include rectangular-wave output (up to two independent waveforms), input pulse width measurement, and measurement of external clock periods.

7.1.1 Features

The features of the free-running timer module are listed below.

- Selection of four clock sources
The free-running counter can be driven by an internal clock source ($\phi/2$, $\phi/8$, or $\phi/32$), or an external clock input (enabling use as an external event counter).
- Two independent comparators
Each comparator can generate an independent waveform.
- Four input capture channels
The current count can be captured on the rising or falling edge (selectable) of an input signal. The four input capture registers can be used separately, or in a buffer mode.
- Counter can be cleared under program control
The free-running counters can be cleared on compare-match A.
- Seven independent interrupts
Compare-match A and B, input capture A to D, and overflow interrupts are requested independently.

7.1.2 Block Diagram

Figure 7.1 shows a block diagram of the free-running timer.

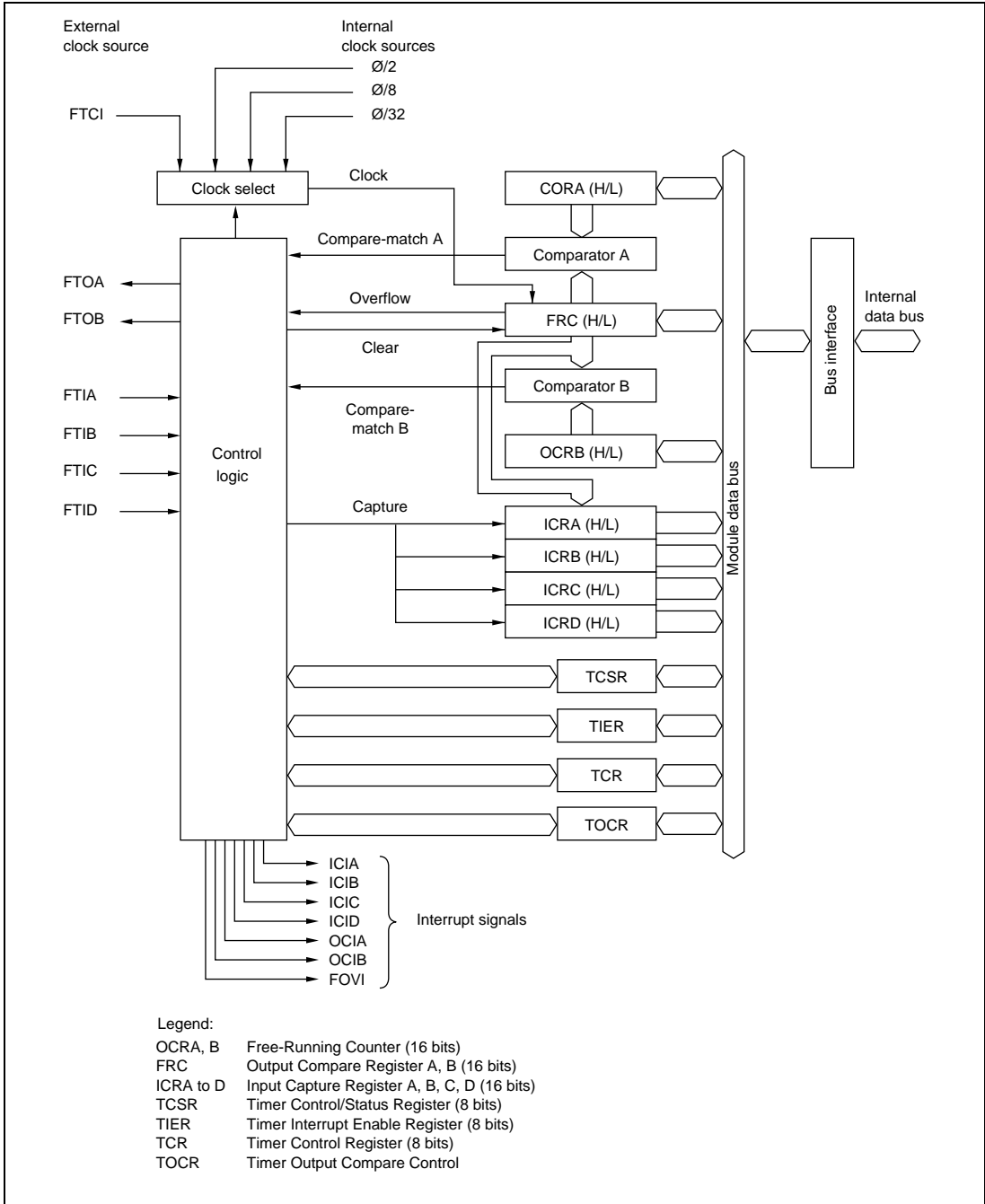

Figure 7.1 Block Diagram of 16-Bit Free-Running Timer

7.1.3 Input and Output Pins

Table 7.1 lists the input and output pins of the free-running timer module.

Table 7.1 Input and Output Pins of Free-Running Timer Module

Name	Abbreviation	I/O	Function
Counter clock input	FTCI	Input	Input of external free-running counter clock signal
Output compare A	FTOA	Output	Output controlled by comparator A
Output compare B	FTOB	Output	Output controlled by comparator B
Input capture A	FTIA	Input	Trigger for capturing current count into input capture register A
Input capture B	FTIB	Input	Trigger for capturing current count into input capture register B
Input capture C	FTIC	Input	Trigger for capturing current count into input capture register C
Input capture D	FTID	Input	Trigger for capturing current count into input capture register D

7.1.4 Register Configuration

Table 7.2 lists the registers of the free-running timer module.

Table 7.2 Register Configuration

Name	Abbreviation	R/W	Initial Value	Address
Timer interrupt enable register	TIER	R/W	H'01	H'FF90
Timer control/status register	TCSR	R/(W)* ¹	H'00	H'FF91
Free-running counter (High)	FRC (H)	R/W	H'00	H'FF92
Free-running counter (Low)	FRC (L)	R/W	H'00	H'FF93
Output compare register A/B (High)* ²	OCRA/B (H)	R/W	H'FF	H'FF94* ²
Output compare register A/B (Low)* ²	OCRA/B (L)	R/W	H'FF	H'FF95* ²
Timer control register	TCR	R/W	H'00	H'FF96
Timer output compare control register	TOCR	R/W	H'E0	H'FF97
Input capture register A (High)	ICRA (H)	R	H'00	H'FF98
Input capture register A (Low)	ICRA (L)	R	H'00	H'FF99

Notes: 1. Software can write a "0" to clear bits 7 to 1, but cannot write a "1" in these bits.

2. OCRA and OCRB share the same addresses. Access is controlled by the OCRS bit in TOCR.

Table 7.2 Register Configuration (cont)

Name	Abbreviation	R/W	Initial Value	Address
Input capture register B (High)	ICRB (H)	R	H'00	H'FF9A
Input capture register B (Low)	ICRB (L)	R	H'00	H'FF9B
Input capture register C (High)	ICRC (H)	R	H'00	H'FF9C
Input capture register C (Low)	ICRC (L)	R	H'00	H'FF9D
Input capture register D (High)	ICRD (H)	R	H'00	H'FF9E
Input capture register D (Low)	ICRD (L)	R	H'00	H'FF9F

7.2 Register Descriptions

7.2.1 Free-Running Counter (FRC)—H'FF92

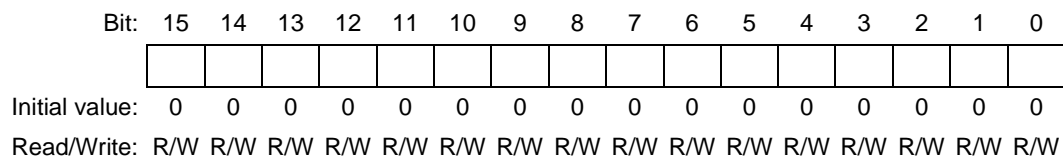

The FRC is a 16-bit readable/writable up-counter that increments on an internal pulse generated from a clock source. The clock source is selected by the clock select 1 and 0 bits (CKS1 and CKS0) of the timer control register (TCR).

When the FRC overflows from H'FFFF to H'0000, the overflow flag (OVF) in the timer control/status register (TCSR) is set to "1."

Because the FRC is a 16-bit register, a temporary register (TEMP) is used when the FRC is written or read. See section 7.3, "CPU Interface," for details.

The FRC is initialized to H'0000 at a reset and in the standby modes. It can also be cleared by compare-match A.

7.2.2 Output Compare Registers A and B (OCRA and OCRB)—H'FF94

Bit:	15	14	13	12	11	10	9	8	7	6	5	4	3	2	1	0
Initial value:	1	1	1	1	1	1	1	1	1	1	1	1	1	1	1	1
Read/Write:	R/W	R/W	R/W	R/W	R/W	R/W	R/W	R/W	R/W	R/W	R/W	R/W	R/W	R/W	R/W	R/W

OCRA and OCRB are 16-bit readable/writable registers, the contents of which are continually compared with the value in the FRC. When a match is detected, the corresponding output compare flag (OCFA or OCFB) is set in the timer control/status register (TCSR).

In addition, if the output enable bit (OEA or OEB) in the timer output compare control register (TOCR) is set to “1,” when the output compare register and FRC values match, the logic level selected by the output level bit (OLVLA or OLVLB) in the TOCR is output at the output compare pin (FTOA or FTOB).

OCRA and OCRB share the same address. They are differentiated by the OCRS bit in the TOCR. A temporary register (TEMP) is used for write access, as explained in section 7.3, “CPU Interface.”

OCRA and OCRB are initialized to H'FFFF at a reset and in the standby modes.

7.2.3 Input Capture Registers A to D (ICRA to ICRD)—H'FF98, H'FF9A, H'FF9C, H'FF9E

Bit:	15	14	13	12	11	10	9	8	7	6	5	4	3	2	1	0
Initial value:	0	0	0	0	0	0	0	0	0	0	0	0	0	0	0	0
Read/Write:	R	R	R	R	R	R	R	R	R	R	R	R	R	R	R	R

Each input capture register is a 16-bit read-only register.

When the rising or falling edge of the signal at an input capture pin (FTIA to FTID) is detected, the current value of the FRC is copied to the corresponding input capture register (ICRA to ICRD).* At the same time, the corresponding input capture flag (ICFA to ICFD) in the timer control/status register (TCSR) is set to “1.” The input capture edge is selected by the input edge select bits (IEDGA to IEDGD) in the timer control register (TCR).

Note: The FRC contents are transferred to the input capture register regardless of the value of the input capture flag (ICFA/B/C/D).

Input capture can be buffered by using the input capture registers in pairs. When the BUFEA bit in the timer control register (TCR) is set to “1,” ICRC is used as a buffer register for ICRA as shown in figure 7.2. When an FTIA input is received, the old ICRA contents are moved into ICRC, and the new FRC count is copied into ICRA.

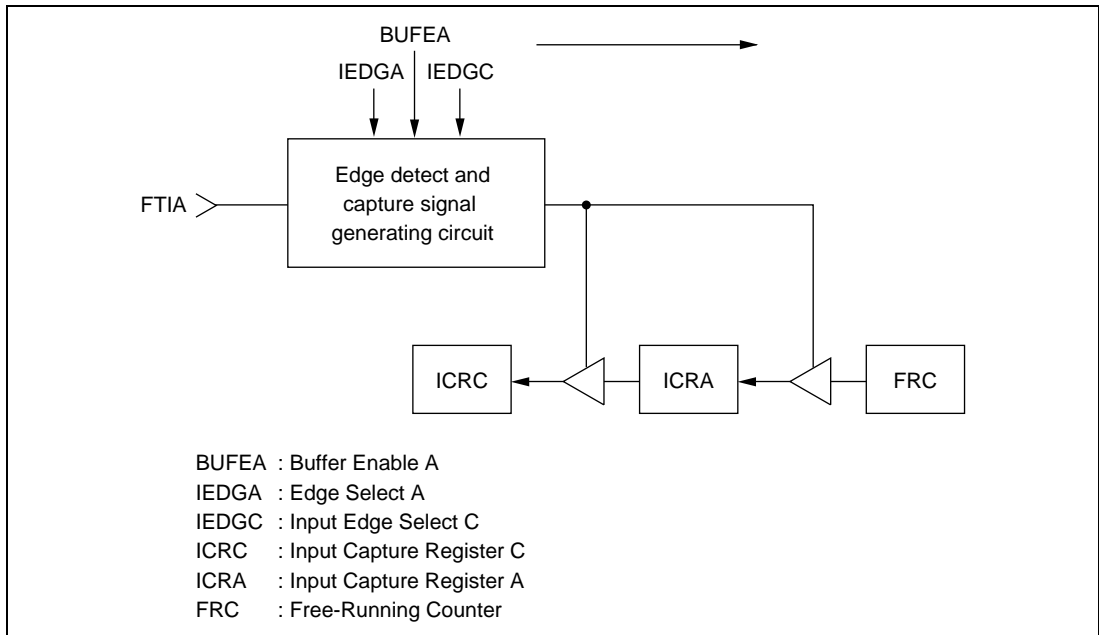

Figure 7.2 Input Capture Buffering

Similarly, when the BUFEB bit in TIER is set to “1,” ICRD is used as a buffer register for ICRB.

When input capture is buffered, if the two input edge bits are set to different values (IEDGA \neq IEDGC or IEDGB \neq IEDGD), then input capture is triggered on both the rising and falling edges of the FTIA or FTIB input signal. If the two input edge bits are set to the same value (IEDGA = IEDGC or IEDGB = IEDGD), then input capture is triggered on only one edge.

Table 7.3 Buffered Input Capture Edge Selection (Example)

IEDGA	IEDGC	Input Capture Edge
0	0	Captured on falling edge of input capture A (FTIA) (Initial value)
0	1	Captured on both rising and falling edges of input capture A (FTIA)
1	0	
1	1	Captured on rising edge of input capture A (FTIA)

Because the input capture registers are 16-bit registers, a temporary register (TEMP) is used when they are read. See section 7.3, “CPU Interface,” for details.

To ensure input capture, the width of the input capture pulse (FTIA, FTIB, FTIC, FTID) should be at least 1.5 system clock periods ($1.5 \cdot \phi$). When triggering is enabled on both edges, the input capture pulse width should be at least 2.5 system clock periods.

The input capture registers are initialized to H'0000 at a reset and in the standby modes.

Note: When input capture is detected, the FRC value is transferred to the input capture register even if the input capture flag is already set.

7.2.4 Timer Interrupt Enable Register (TIER)-H'FF90

Bit:	7	6	5	4	3	2	1	0
	ICIAE	ICIBE	ICICE	ICIDE	OCIAE	OCIBE	OVIE	—
Initial value:	0	0	0	0	0	0	0	1
Read/Write:	R/W	R/W	R/W	R/W	R/W	R/W	R/W	—

The TIER is an 8-bit readable/writable register that enables and disables interrupts.

The TIER is initialized to H'01 (all interrupts disabled) at a reset and in the standby modes.

Bit 7—Input Capture Interrupt A Enable (ICIAE): This bit selects whether to request input capture interrupt A (ICIA) when input capture flag A (ICFA) in the timer status/control register (TCSR) is set to “1.”

Bit 7

ICIAE	Description
0	Input capture interrupt request A (ICIA) is disabled. (Initial value)
1	Input capture interrupt request A (ICIA) is enabled.

Bit 6—Input Capture Interrupt B Enable (ICIBE): This bit selects whether to request input capture interrupt B (ICIB) when input capture flag B (ICFB) in the timer status/control register (TCSR) is set to “1.”

Bit 6

ICIBE	Description
0	Input capture interrupt request B (ICIB) is disabled. (Initial value)
1	Input capture interrupt request B (ICIB) is enabled.

Bit 5—Input Capture Interrupt C Enable (ICICE): This bit selects whether to request input capture interrupt C (ICIC) when input capture flag C (ICFC) in the timer status/control register (TCSR) is set to “1.”

Bit 5

ICICE	Description
0	Input capture interrupt request C (ICIC) is disabled. (Initial value)
1	Input capture interrupt request C (ICIC) is enabled.

Bit 4—Input Capture Interrupt D Enable (ICIDE): This bit selects whether to request input capture interrupt D (ICID) when input capture flag D (ICFD) in the timer status/control register (TCSR) is set to “1.”

Bit 4 ICIDE	Description
0	Input capture interrupt request D (ICID) is disabled. (Initial value)
1	Input capture interrupt request D (ICID) is enabled.

Bit 3—Output Compare Interrupt A Enable (OCIAE): This bit selects whether to request output compare interrupt A (OCIA) when output compare flag A (OCFA) in the timer status/control register (TCSR) is set to “1.”

Bit 3 OCIAE	Description
0	Output compare interrupt request A (OCIA) is disabled. (Initial value)
1	Output compare interrupt request A (OCIA) is enabled.

Bit 2—Output Compare Interrupt B Enable (OCIBE): This bit selects whether to request output compare interrupt B (OCIB) when output compare flag B (OCFB) in the timer status/control register (TCSR) is set to “1.”

Bit 2 OCIBE	Description
0	Output compare interrupt request B (OCIB) is disabled. (Initial value)
1	Output compare interrupt request B (OCIB) is enabled.

Bit 1—Timer overflow Interrupt Enable (OVIE): This bit selects whether to request a free-running timer overflow interrupt (FOVI) when the timer overflow flag (OVF) in the timer status/control register (TCSR) is set to “1.”

Bit 1 OVIE	Description
0	Timer overflow interrupt request (FOVI) is disabled. (Initial value)
1	Timer overflow interrupt request (FOVI) is enabled.

Bit 0—Reserved: This bit cannot be modified and is always read as “1.”

7.2.5 Timer Control/Status Register (TCSR)—H'FF91

Bit:	7	6	5	4	3	2	1	0
	ICFA	ICFB	ICFC	ICFD	OCFA	OCFB	OVF	CCLRA
Initial value:	0	0	0	0	0	0	0	0
Read/Write:	R/(W)*	R/(W)*	R/(W)*	R/(W)*	R/(W)*	R/(W)*	R/(W)*	R/W

The TCSR is an 8-bit readable and partially writable* register that contains the seven interrupt flags and specifies whether to clear the counter on compare-match A (when the FRC and OCRA values match).

Note: Software can write a “0” in bits 7 to 1 to clear the flags, but cannot write a “1” in these bits.

The TCSR is initialized to H'00 at a reset and in the standby modes.

Bit 7—Input Capture Flag A (ICFA): This status bit is set to “1” to flag an input capture A event. If BUFEA = “0,” ICFA indicates that the FRC value has been copied to ICRA. If BUFEA = “1,” ICFA indicates that the old ICRA value has been moved into ICRC and the new FRC value has been copied to ICRA.

ICFA must be cleared by software. It is set by hardware, however, and cannot be set by software.

Bit 7

ICFA	Description
0	To clear ICFA, the CPU must read ICFA after it has been set to “1,” then write a “0” in this bit. (Initial value)
1	This bit is set to 1 when an FTIA input signal causes the FRC value to be copied to ICRA.

Bit 6—Input Capture Flag B (ICFB): This status bit is set to “1” to flag an input capture B event. If BUFEB = “0,” ICFB indicates that the FRC value has been copied to ICRB. If BUFEB = “1,” ICFB indicates that the old ICRB value has been moved into ICRD and the new FRC value has been copied to ICRB.

ICFB must be cleared by software. It is set by hardware, however, and cannot be set by software.

Bit 6

ICFB	Description
0	To clear ICFB, the CPU must read ICFB after it has been set to “1,” then write a “0” in this bit. (Initial value)
1	This bit is set to 1 when an FTIB input signal causes the FRC value to be copied to ICRB.

Bit 5—Input Capture Flag C (ICFC): This status bit is set to “1” to flag input of a rising or falling edge of FTIC as selected by the IEDGC bit. When BUFEA = “0,” this indicates capture of the FRC count in ICRC. When BUFEA = “1,” however, the FRC count is not captured, so ICFC becomes simply an external interrupt flag. In other words, the buffer mode frees FTIC for use as a general-purpose interrupt signal (which can be enabled or disabled by the ICICE bit).

ICFC must be cleared by software. It is set by hardware, however, and cannot be set by software.

Bit 5

ICFC	Description
0	To clear ICFC, the CPU must read ICFC after it has been set to “1,” then write a “0” in this bit. (Initial value)
1	This bit is set to 1 when an FTIC input signal is received.

Bit 4—Input Capture Flag D (ICFD): This status bit is set to “1” to flag input of a rising or falling edge of FTID as selected by the IEDGD bit. When BUFEB = “0,” this indicates capture of the FRC count in ICRD. When BUFEB = “1,” however, the FRC count is not captured, so ICFD becomes simply an external interrupt flag. In other words, the buffer mode frees FTID for use as a general-purpose interrupt signal (which can be enabled or disabled by the ICIDE bit).

ICFD must be cleared by software. It is set by hardware, however, and cannot be set by software.

Bit 4

ICFD	Description
0	To clear ICFD, the CPU must read ICFD after it has been set to “1,” then write a “0” in this bit. (Initial value)
1	This bit is set to 1 when an FTID input signal is received.

Bit 3—Output Compare Flag A (OCFA): This status flag is set to “1” when the FRC value matches the OCRA value. This flag must be cleared by software. It is set by hardware, however, and cannot be set by software.

Bit 3	
OCFA	Description
0	To clear OCFA, the CPU must read OCFA after it has been set to “1,” (Initial value) then write a “0” in this bit.
1	This bit is set to 1 when FRC = OCRA.

Bit 2—Output Compare Flag B (OCFB): This status flag is set to “1” when the FRC value matches the OCRB value. This flag must be cleared by software. It is set by hardware, however, and cannot be set by software.

Bit 2	
OCFB	Description
0	To clear OCFB, the CPU must read OCFB after it has been set to “1,” (Initial value) then write a “0” in this bit.
1	This bit is set to 1 when FRC = OCRB.

Bit 1—Timer Overflow Flag (OVF): This status flag is set to “1” when the FRC overflows (changes from H'FFFF to H'0000). This flag must be cleared by software. It is set by hardware, however, and cannot be set by software.

Bit 1	
OVF	Description
0	To clear OVF, the CPU must read OVF after it has been set to “1,” (Initial value) then write a “0” in this bit.
1	This bit is set to 1 when FRC changes from H'FFFF to H'0000.

Bit 0—Counter Clear A (CCLRA): This bit selects whether to clear the FRC at compare-match A (when the FRC and OCRA values match).

Bit 0	
CCLRA	Description
0	The FRC is not cleared. (Initial value)
1	The FRC is cleared at compare-match A.

7.2.6 Timer Control Register (TCR)-H'FF96

Bit:	7	6	5	4	3	2	1	0
	IEDGA	IEDGB	IEDGC	IEDGD	BUFEA	BUFEB	CKS1	CKS0
Initial value:	0	0	0	0	0	0	0	0
Read/Write:	R/W	R/W	R/W	R/W	R/W	R/W	R/W	R/W

The TCR is an 8-bit readable/writable register that selects the rising or falling edge of the input capture signals, enables the input capture buffer mode, and selects the FRC clock source.

The TCR is initialized to H'00 at a reset and in the standby modes.

Bit 7—Input Edge Select A (IEDGA): This bit causes input capture A events to be recognized on the selected edge of the input capture A signal (FTIA).

Bit 7

IEDGA	Description
0	Input capture A events are recognized on the falling edge of FTIA. (Initial value)
1	Input capture A events are recognized on the rising edge of FTIA.

Bit 6—Input Edge Select B (IEDGB): This bit causes input capture B events to be recognized on the selected edge of the input capture B signal (FTIB).

Bit 6

IEDGB	Description
0	Input capture B events are recognized on the falling edge of FTIB. (Initial value)
1	Input capture B events are recognized on the rising edge of FTIB.

Bit 5—Input Edge Select C (IEDGC): This bit causes input capture C events to be recognized on the selected edge of the input capture C signal (FTIC).

Bit 5

IEDGC	Description
0	Input capture C events are recognized on the falling edge of FTIC. (Initial value)
1	Input capture C events are recognized on the rising edge of FTIC.

Bit 4—Input Edge Select D (IEDGD): This bit causes input capture D events to be recognized on the selected edge of the input capture D signal (FTID).

Bit 4

IEDGD	Description
0	Input capture D events are recognized on the falling edge of FTID. (Initial value)
1	Input capture D events are recognized on the rising edge of FTID.

Bit 3—Buffer Enable A (BUFEA): This bit selects whether to use ICRC as a buffer register for ICRA.

Bit 3

BUFEA	Description
0	ICRC is used for input capture C. (Initial value)
1	ICRC is used as a buffer register for input capture A. Input C is not captured.

Bit 2—Buffer Enable B (BUFEB): This bit selects whether to use ICRD as a buffer register for ICRB.

Bit 2

BUFEB	Description
0	ICRD is used for input capture D. (Initial value)
1	ICRD is used as a buffer register for input capture B. Input D is not captured.

Bits 1 and 0—Clock Select (CKS1 and CKS0): These bits select external clock input or one of three internal clock sources for the FRC. External clock pulses are counted on the rising edge.

Bit 1 CKS1	Bit 0 CKS0	Description
0	0	$\phi/2$ Internal clock source (Initial value)
0	1	$\phi/8$ Internal clock source
1	0	$\phi/32$ Internal clock source
1	1	External clock source (rising edge)

7.2.7 Timer Output Compare Control Register (TOCR)—H'FF97

Bit:	7	6	5	4	3	2	1	0
	—	—	—	OCRS	OEA	OEB	OLVLA	OLVLB
Initial value:	1	1	1	0	0	0	0	0
Read/Write:	—	—	—	R/W	R/W	R/W	R/W	R/W

The TOCR is an 8-bit readable/writable register that controls the output compare function.

The TOCR is initialized to H'E0 at a reset and in the standby modes.

Bits 7 to 5—Reserved: These bits cannot be modified and are always read as “1.”

Bit 4—Output Compare Register Select (OCRS): When the CPU accesses addresses H'FF94 and H'FF95, this bit directs the access to either OCRA or OCRB. These two registers share the same addresses as follows:

Upper byte of OCRA and upper byte of OCRB: H'FF94

Lower byte of OCRA and lower byte of OCRB: H'FF95

Bit 4

OCRS	Description	
0	The CPU can access OCRA.	(Initial value)
1	The CPU can access OCRB.	

Bit 3—Output Enable A (OEA): This bit enables or disables output of the output compare A signal (FTOA).

Bit 3

OEA	Description	
0	Output compare A output is disabled.	(Initial value)
1	Output compare A output is enabled.	

Bit 2—Output Enable B (OEB): This bit enables or disables output of the output compare B signal (FTOB).

Bit 2

OEB	Description	
0	Output compare B output is disabled.	(Initial value)
1	Output compare B output is enabled.	

Bit 1—Output Level A (OLVLA): This bit selects the logic level to be output at the FTOA pin when the FRC and OCRA values match.

Bit 1

OLVLA	Description
0	A “0” logic level (Low) is output for compare-match A. (Initial value)
1	A “1” logic level (High) is output for compare-match A.

Bit 0—Output Level B (OLVLB): This bit selects the logic level to be output at the FTOB pin when the FRC and OCRB values match.

Bit 0

OLVLB	Description
0	A “0” logic level (Low) is output for compare-match B. (Initial value)
1	A “1” logic level (High) is output for compare-match B.

7.3 CPU Interface

The free-running counter (FRC), output compare registers (OCRA and OCRB), and input capture registers (ICRA to ICRD) are 16-bit registers, but they are connected to an 8-bit data bus. When the CPU accesses these registers, to ensure that both bytes are written or read simultaneously, the access is performed using an 8-bit temporary register (TEMP).

These registers are written and read as follows:

- **Register Write**
When the CPU writes to the upper byte, the byte of write data is placed in TEMP. Next, when the CPU writes to the lower byte, this byte of data is combined with the byte in TEMP and all 16 bits are written in the register simultaneously.
- **Register Read**
When the CPU reads the upper byte, the upper byte of data is sent to the CPU and the lower byte is placed in TEMP. When the CPU reads the lower byte, it receives the value in TEMP. (As an exception, when the CPU reads OCRA or OCRB, it reads both the upper and lower bytes directly, without using TEMP.)

Programs that access these registers should normally use word access. Equivalently, they may access first the upper byte, then the lower byte by two consecutive byte accesses. Data will not be transferred correctly if the bytes are accessed in reverse order, or if only one byte is accessed.

Coding Examples

To write the contents of general register R0 to OCRA: `MOV.W R0, @OCRA`
To transfer the contents of ICRA to general register R0: `MOV.W @ICRA, R0`

Figure 7.3 shows the data flow when the FRC is accessed. The other registers are accessed in the same way.

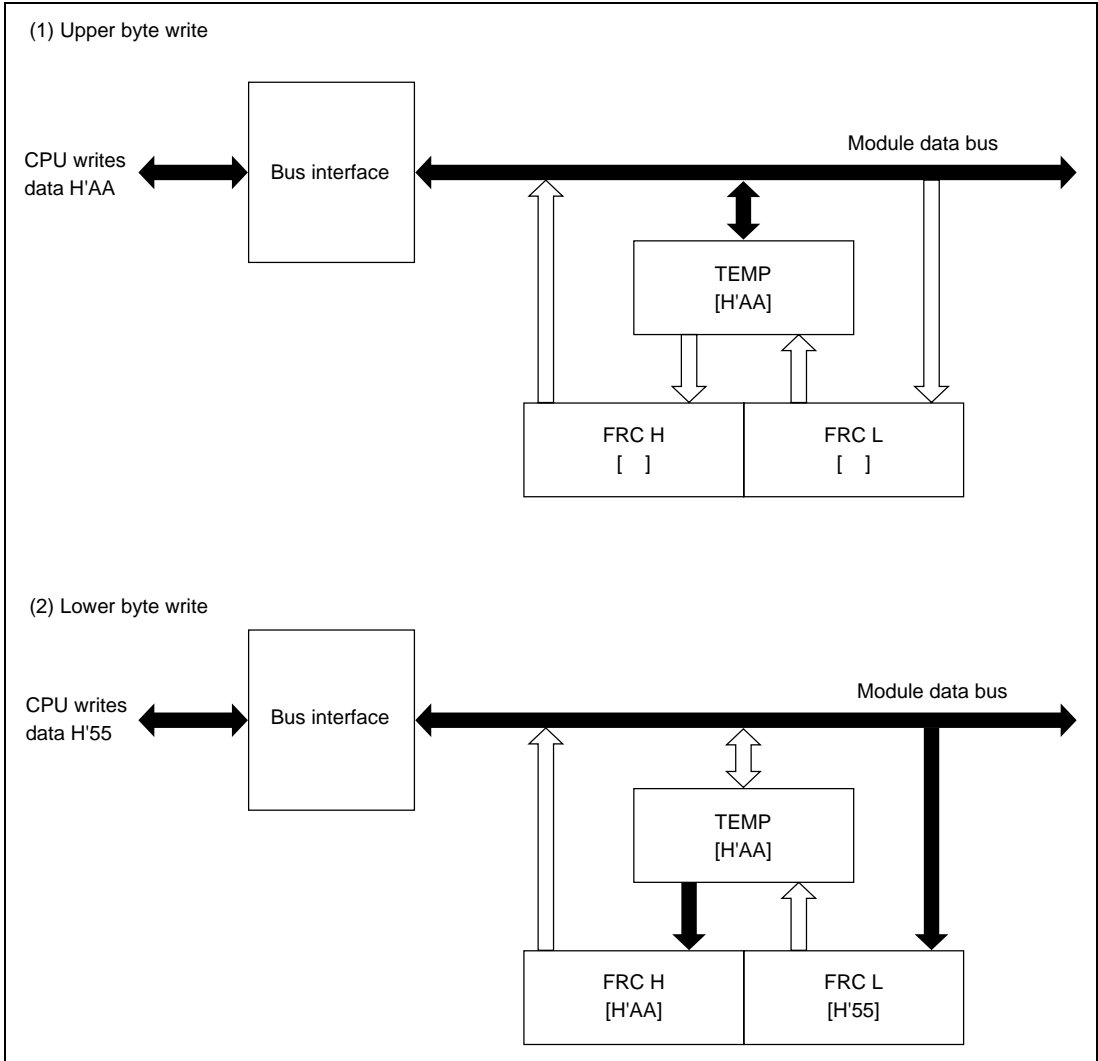

Figure 7.3 (a) Write Access to FRC (when CPU writes H'AA55)

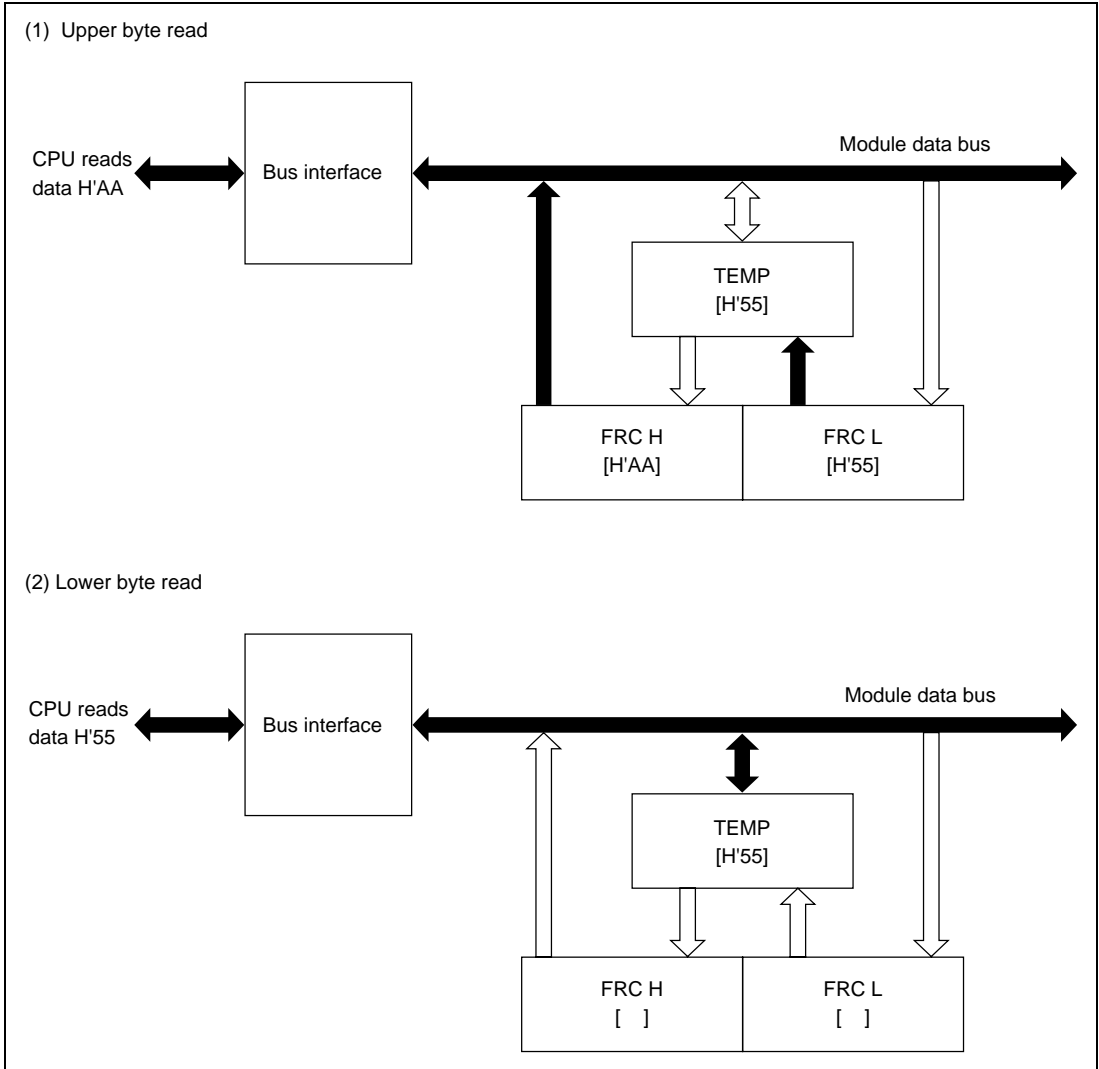

Figure 7.3 (b) Read Access to FRC (when FRC contains H'AA55)

7.4 Operation

7.4.1 FRC Incrementation Timing

The FRC increments on a pulse generated once for each period of the selected (internal or external) clock source. The clock source is selected by bits CKS0 and CKS1 in the TCR.

Internal Clock: The internal clock sources ($\phi/2$, $\phi/8$, $\phi/32$) are created from the system clock (ϕ) by a prescaler. The FRC increments on a pulse generated from the falling edge of the prescaler output. See figure 7.4.

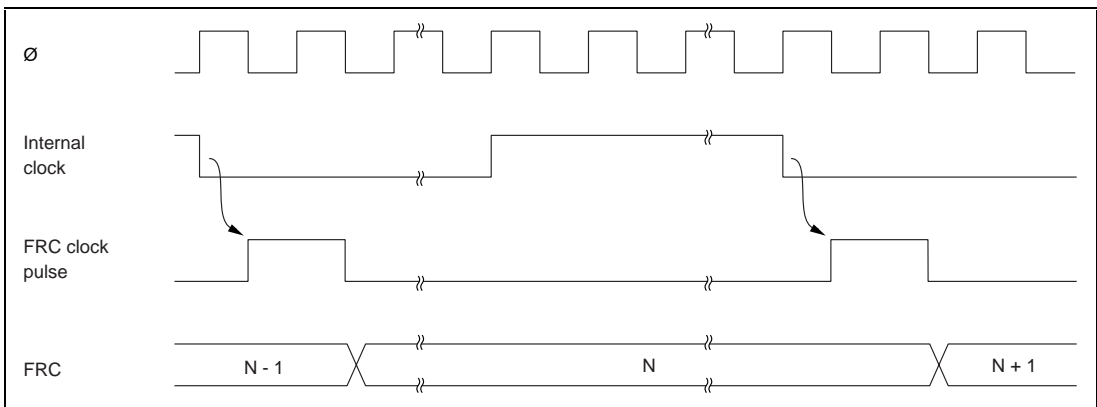

Figure 7.4 Increment Timing for Internal Clock Source

External Clock: If external clock input is selected, the FRC increments on the rising edge of the FTCl clock signal. Figure 7.5 shows the increment timing.

The pulse width of the external clock signal must be at least 1.5 system clock (ϕ) periods. The counter will not increment correctly if the pulse width is shorter than 1.5 system clock periods.

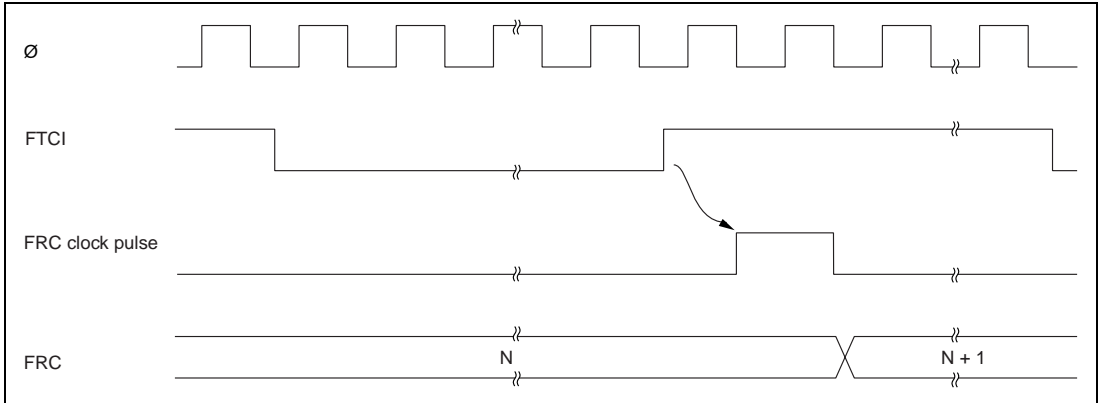

Figure 7.5 Increment Timing for External Clock Source

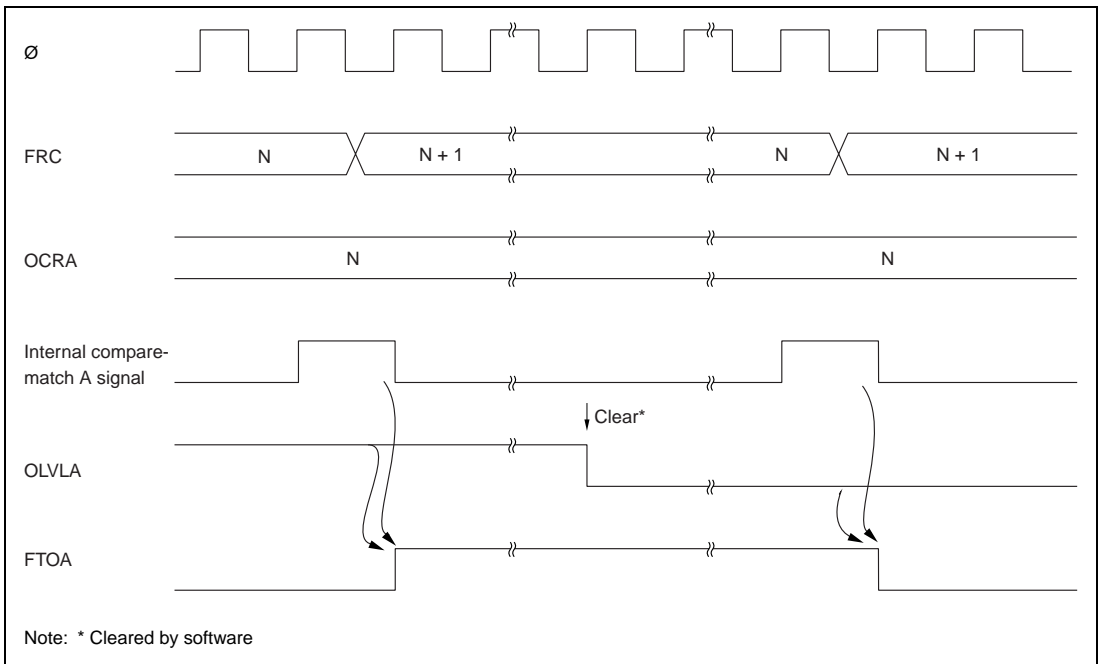

Figure 7.6 Minimum External Clock Pulse Width

7.4.2 Output Compare Timing

(1) Setting of Output Compare Flags A and B (OCFA and OCFB): The output compare flags are set to “1” by an internal compare-match signal generated when the FRC value matches the OCRA or OCRB value. This compare-match signal is generated at the last state in which the two values match, just before the FRC increments to a new value.

Accordingly, when the FRC and OCR values match, the compare-match signal is not generated until the next period of the clock source. Figure 7.7 shows the timing of the setting of the output compare flags.

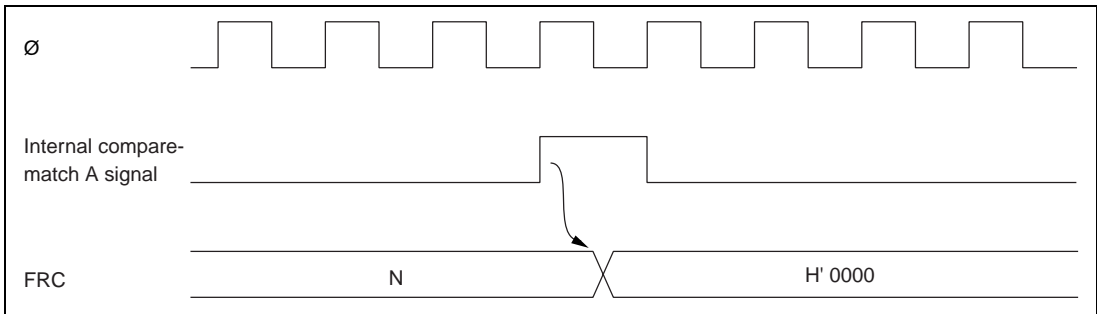

Figure 7.7 Setting of Output Compare Flags

(2) Output Timing: When a compare-match occurs, the logic level selected by the output level bit (OLVLA or OLVLB) in TOCR is output at the output compare pin (FTOA or FTOB).

Figure 7.8 shows the timing of this operation for compare-match A.

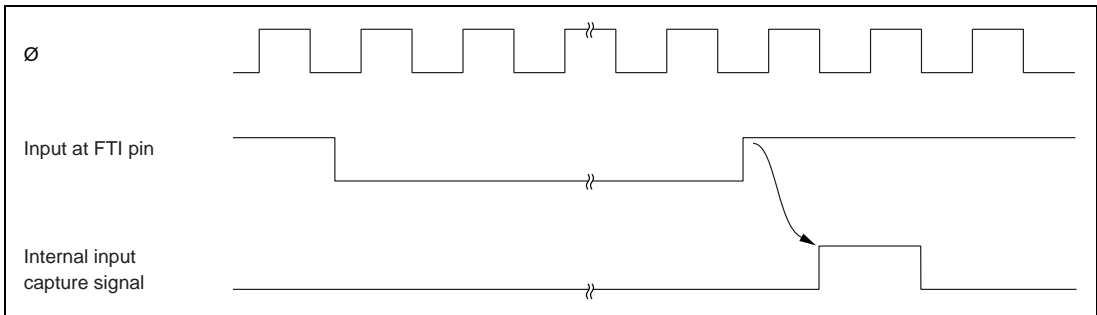

Figure 7.8 Timing of Output Compare A

(3) FRC Clear Timing: If the CCLRA bit in the TCSR is set to “1,” the FRC is cleared when compare-match A occurs. Figure 7.9 shows the timing of this operation.

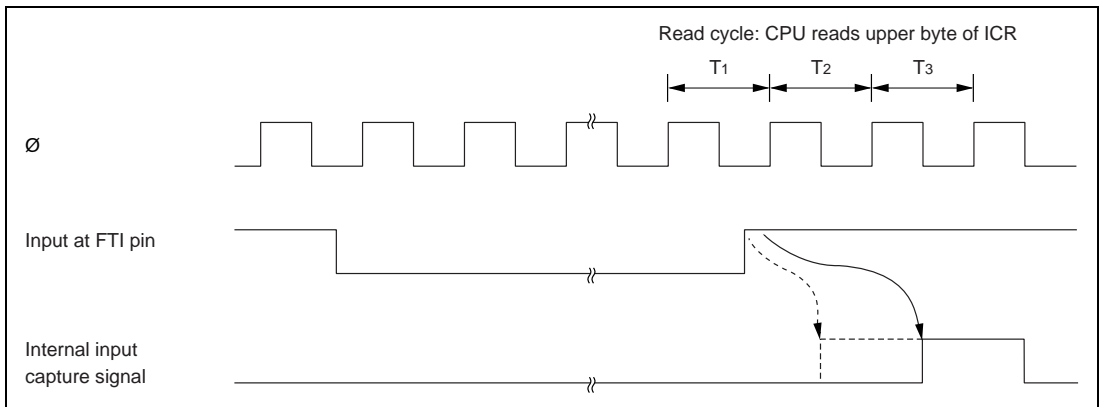

Figure 7.9 Clearing of FRC by Compare-Match A

7.4.3 Input Capture Timing

(1) Input Capture Timing: An internal input capture signal is generated from the rising or falling edge of the signal at the input capture pin FTIx ($x = A, B, C, D$), as selected by the corresponding IEDGx bit in TCR. Figure 7.10 shows the usual input capture timing when the rising edge is selected (IEDGx = “1”).

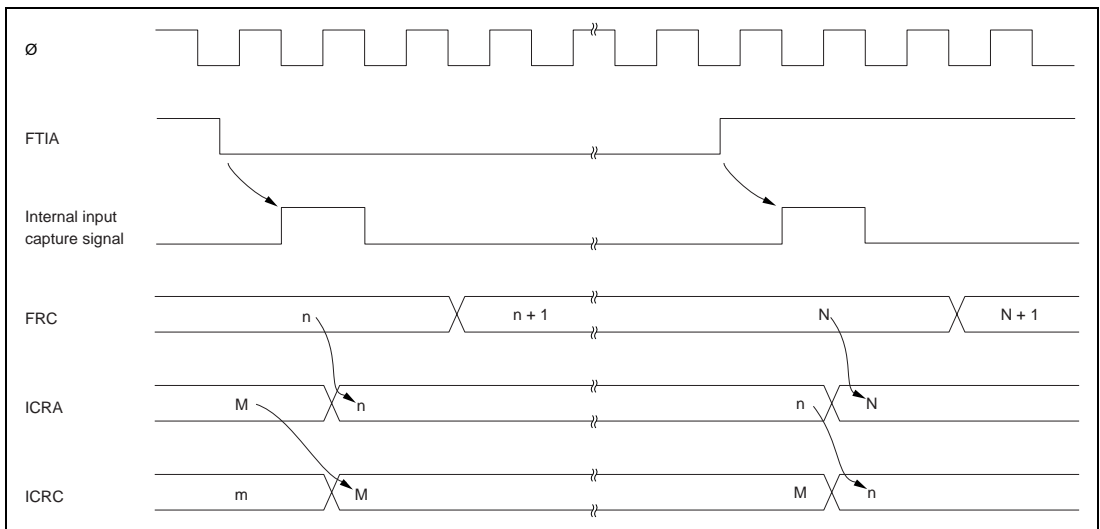

Figure 7.10 Input Capture Timing (Usual case)

If the upper byte of ICRA/B/C/D is being read when the corresponding input capture signal arrives, the internal input capture signal is delayed by one state. Figure 7.11 shows the timing for this case.

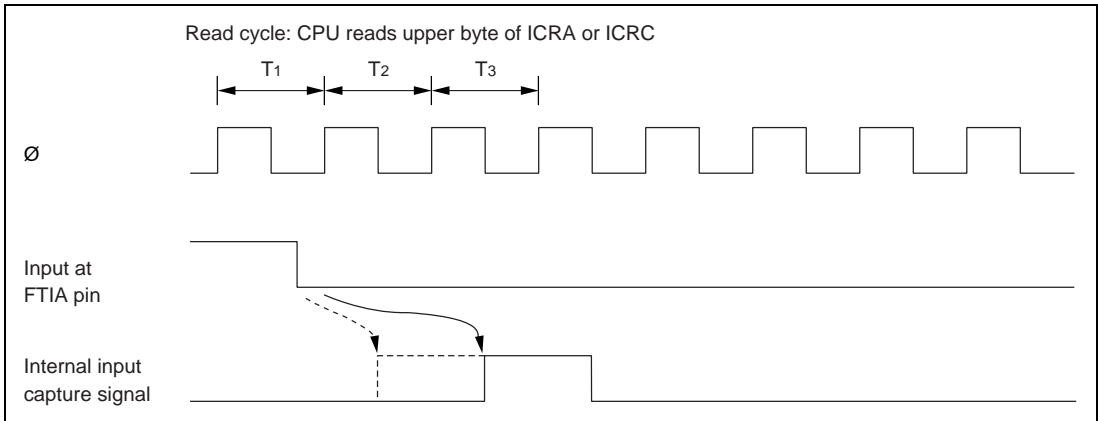

Figure 7.11 Input Capture Timing (1-State delay)

In buffer mode, this delay occurs if the CPU is reading either of the two registers concerned. When ICRA and ICRC are used in buffer mode, for example, if the upper byte of either ICRA or ICRC is being read when the FTIA input arrives, the internal input capture signal is delayed by one state. Figure 7.12 shows the timing for this case. The case of ICRB and ICRD is similar.

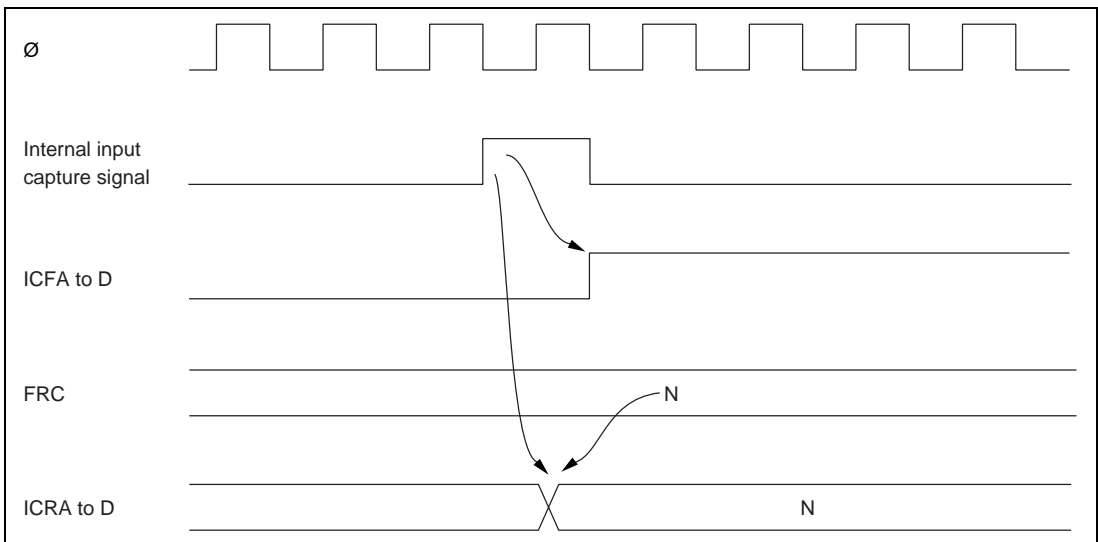

Figure 7.12 Input Capture Timing (1-State delay, buffer mode)

Figure 7.13 shows how input capture operates when ICRA and ICRC are used in buffer mode and IEDGA and IEDGC are set to different values (IEDGA = 0 and IEDGC = 1, or IEDGA = 1 and IEDGC = 0), so that input capture is performed on both the rising and falling edges of FTIA.

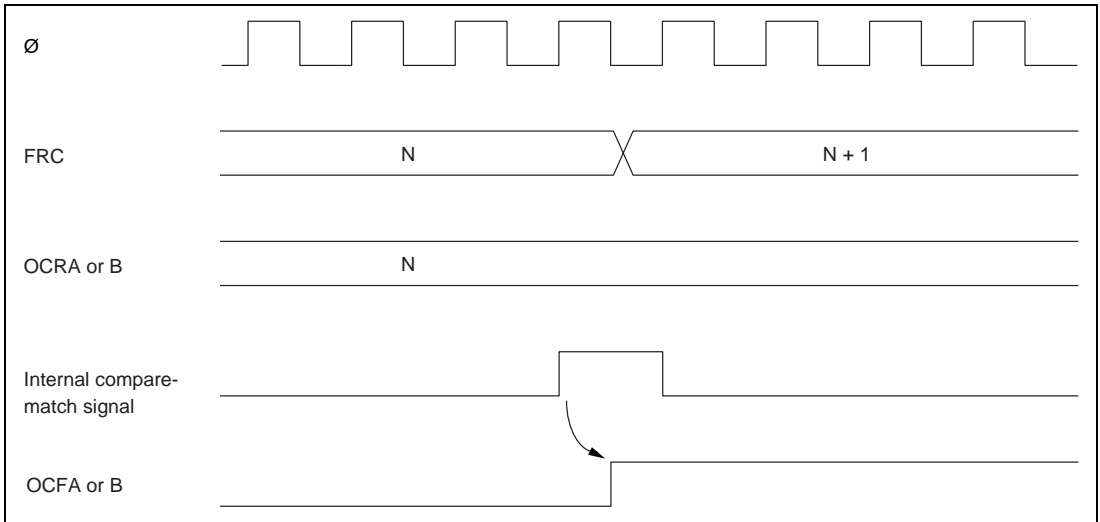

Figure 7.13 Buffered Input Capture with Both Edges Selected

In this mode, input capture does not cause the FRC contents to be copied to ICRC. However, input capture flag C still sets on the input capture edge selected by IEDGC, and if the interrupt enable bit (ICICE) is set, a CPU interrupt is requested.

The situation when ICRB and ICRD are used in buffer mode is similar.

(2) Timing of Input Capture Flag (ICF) Setting: The input capture flag ICF_x (x = A, B, C, D) is set to “1” by the internal input capture signal. Figure 7.14 shows the timing of this operation.

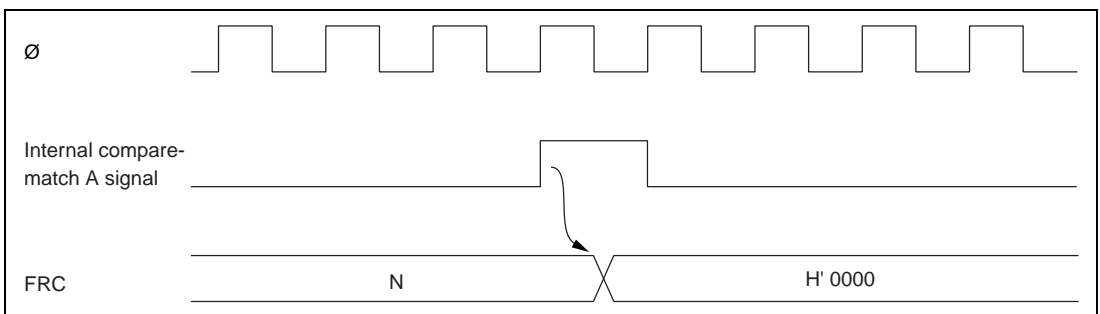

Figure 7.14 Setting of Input Capture Flag

7.4.4 Setting of FRC Overflow Flag (OVF)

The FRC overflow flag (OVF) is set to “1” when the FRC overflows (changes from H'FFFF to H'0000). Figure 7.15 shows the timing of this operation.

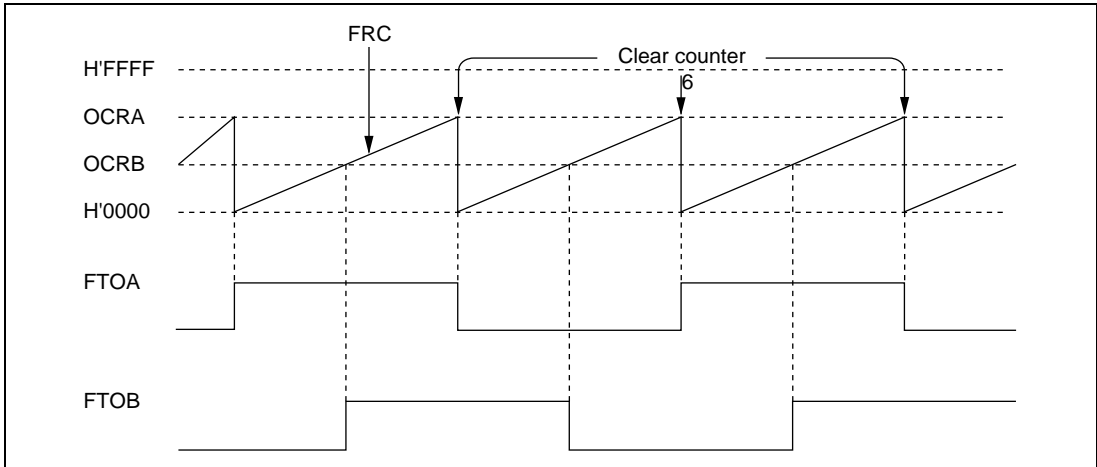

Figure 7.15 Setting of Overflow Flag (OVF)

7.5 Interrupts

The free-running timer can request seven types of interrupts: input capture A to D (ICIA, ICIB, ICIC, ICID), output compare A and B (OCIA and OCIB), and overflow (FOVI). Each interrupt is requested when the corresponding enable and flag bits are set. Independent signals are sent to the interrupt controller for each type of interrupt. Table 7.4 lists information about these interrupts.

Table 7.4 Free-Running Timer Interrupts

Interrupt	Description	Priority
ICIA	Requested when ICFA and ICIAE are set	High
ICIB	Requested when ICFB and ICIBE are set	
ICIC	Requested when ICFC and ICICE are set	
ICID	Requested when ICFD and ICIDE are set	
OCIA	Requested when OCFA and OCIAE are set	
OCIB	Requested when OCFB and OCIBE are set	
FOVI	Requested when OVF and OVIE are set	

7.6 Sample Application

In the example below, the free-running timer is used to generate two square-wave outputs with a 50% duty cycle and arbitrary phase relationship. The programming is as follows:

- (1) The CCLRA bit in the TCSR is set to "1."
- (2) Each time a compare-match interrupt occurs, software inverts the corresponding output level bit in TOCR (OLVLA or OLVLB).

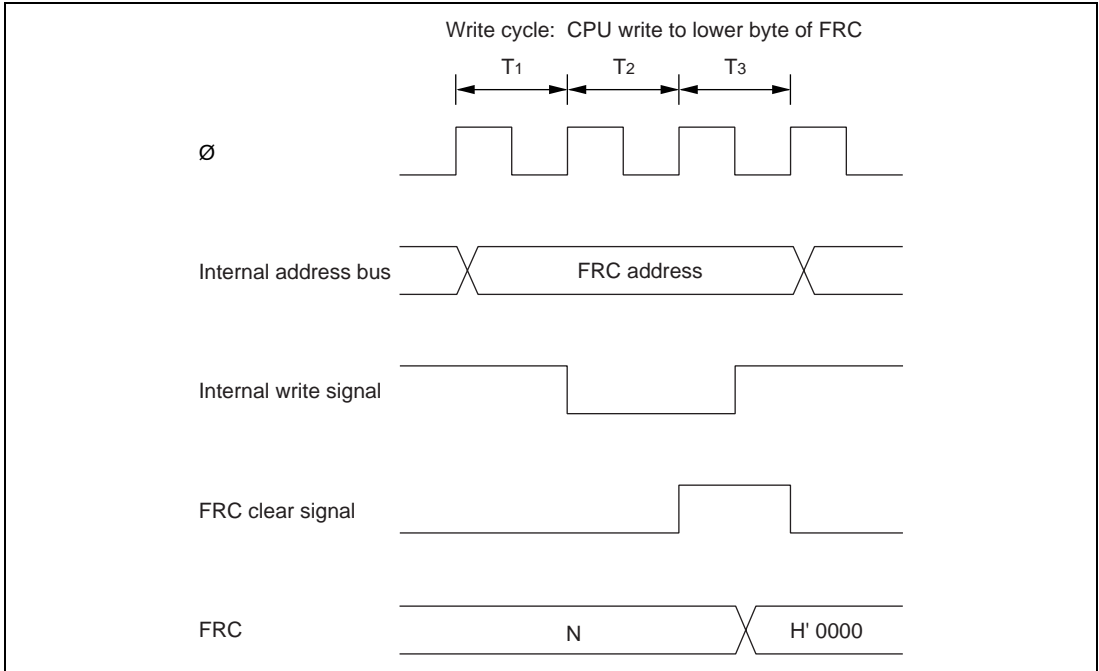

Figure 7.16 Square-Wave Output (Example)

7.7 Application Notes

Application programmers should note that the following types of contention can occur in the free-running timers.

(1) Contention between FRC Write and Clear: If an internal counter clear signal is generated during the T_3 state of a write cycle to the lower byte of the free-running counter, the clear signal takes priority and the write is not performed.

Figure 7.17 shows this type of contention.

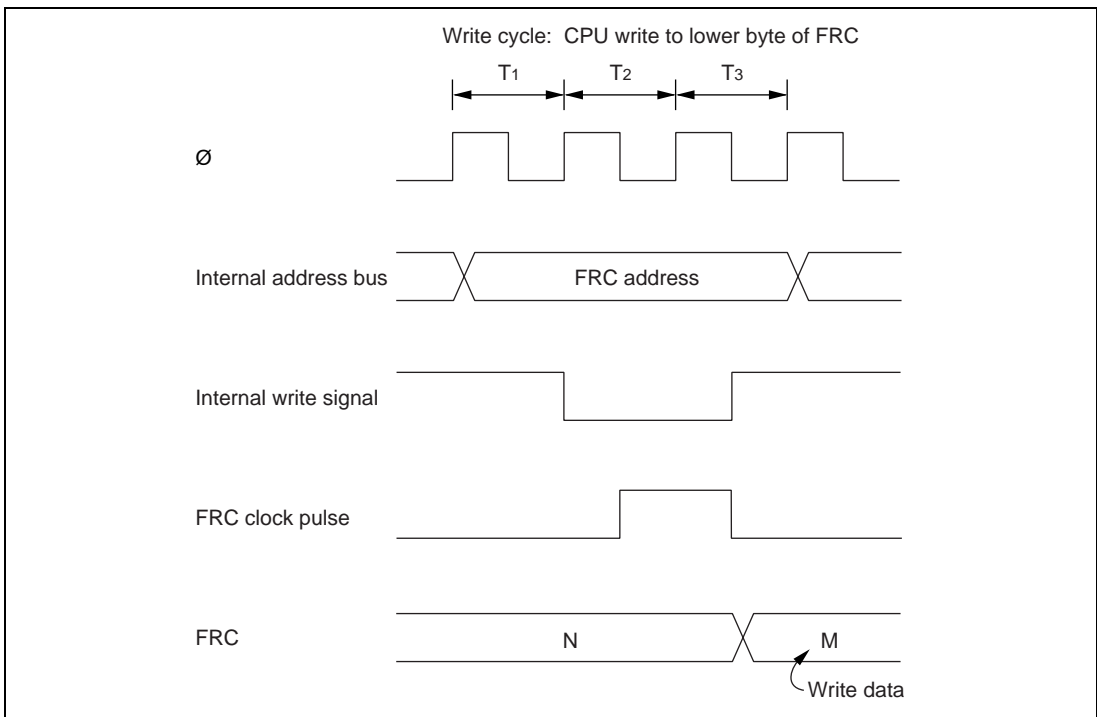

Figure 7.17 FRC Write-Clear Contention

(2) Contention between FRC Write and Increment: If an FRC increment pulse is generated during the T_3 state of a write cycle to the lower byte of the free-running counter, the write takes priority and the FRC is not incremented.

Figure 7.18 shows this type of contention.

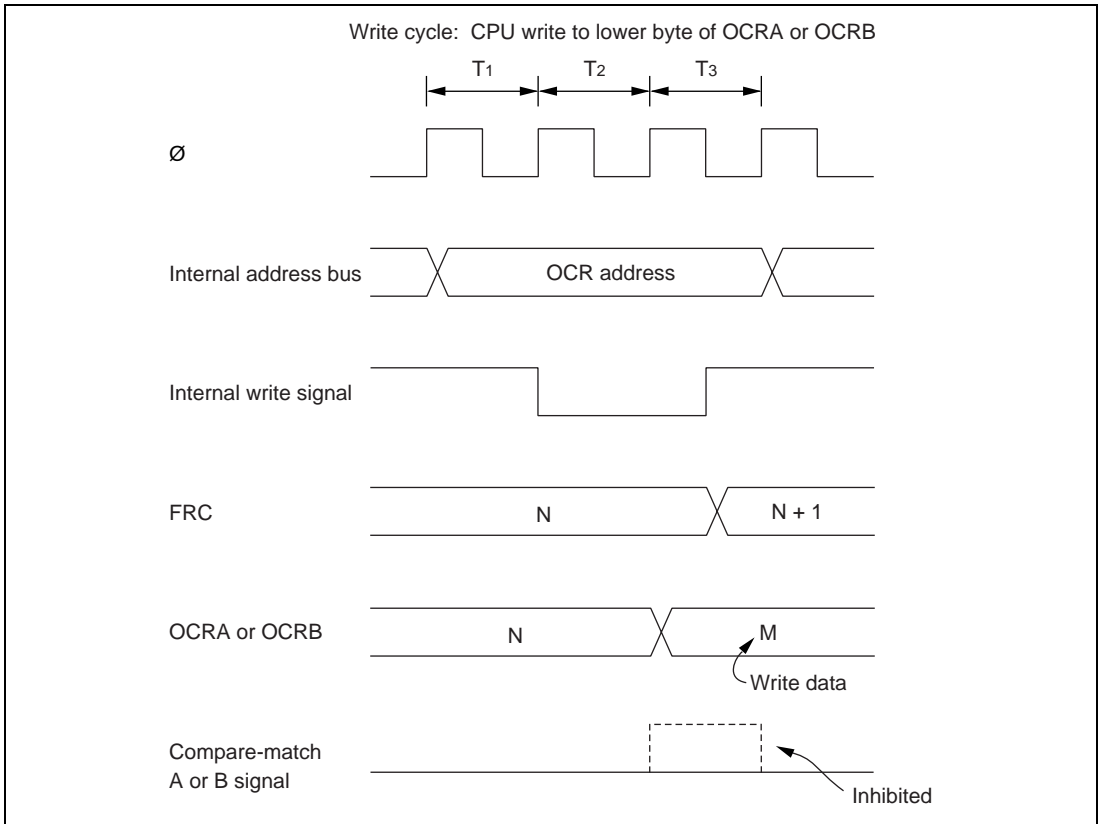

Figure 7.18 FRC Write-Increment Contention

(3) Contention between OCR Write and Compare-Match: If a compare-match occurs during the T₃ state of a write cycle to the lower byte of OCRA or OCRB, the write takes priority and the compare-match signal is inhibited.

(4) Incrementation Caused by Changing of Internal Clock Source: When an internal clock source is changed, the changeover may cause the FRC to increment. This depends on the time at which the clock select bits (CKS1 and CKS0) are rewritten, as shown in table 7.5.

The pulse that increments the FRC is generated at the falling edge of the internal clock source. If clock sources are changed when the old source is High and the new source is Low, as in case No. 3 in table 7.5, the changeover generates a falling edge that triggers the FRC increment clock pulse.

Switching between an internal and external clock source can also cause the FRC to increment.

Table 7.5 Effect of Changing Internal Clock Sources

No.	Description	Timing chart
1	Low → Low: CKS1 and CKS0 are rewritten while both clock sources are Low.	<p>The timing chart for Case 1 shows four signals over time. The 'Old clock source' starts high, then falls to low. The 'New clock source' starts low, then rises to high. The 'FRC clock pulse' is a narrow pulse that occurs at the falling edge of the old clock source. The 'FRC' signal is shown as a horizontal line that increments from 'N' to 'N + 1' at the moment of the falling edge. A vertical dashed line labeled 'CKS rewrite' is positioned between the falling edge of the old source and the rising edge of the new source.</p>
2	Low → High: CKS1 and CKS0 are rewritten while old clock source is Low and new clock source is High.	<p>The timing chart for Case 2 shows four signals over time. The 'Old clock source' starts low, then rises to high. The 'New clock source' starts high, then falls to low. The 'FRC clock pulse' is a narrow pulse that occurs at the falling edge of the new clock source. The 'FRC' signal is shown as a horizontal line that increments from 'N' to 'N + 1' at the first falling edge, and then to 'N + 2' at the second falling edge. A vertical dashed line labeled 'CKS rewrite' is positioned between the rising edge of the old source and the falling edge of the new source.</p>

Table 7.5 Effect of Changing Internal Clock Sources (cont)

No.	Description	Timing chart
3	High → Low: CKS1 and CKS0 are rewritten while old clock source is High and new clock source is Low.	
4	High → High: CKS1 and CKS0 are rewritten while both clock sources are High.	

Note: The switching of clock sources is regarded as a falling edge that increments the FRC.

Section 8 8-Bit Timers

8.1 Overview

The H8/338 Series includes an 8-bit timer module with two channels (TMR0 and TMR1). Each channel has an 8-bit counter (TCNT) and two time constant registers (TCORA and TCORB) that are constantly compared with the TCNT value to detect compare-match events. One application of the 8-bit timer module is to generate a rectangular-wave output with an arbitrary duty cycle.

8.1.1 Features

The features of the 8-bit timer module are listed below.

- Selection of seven clock sources
The counters can be driven by one of six internal clock signals or an external clock input (enabling use as an external event counter).
- Selection of three ways to clear the counters
The counters can be cleared on compare-match A or B, or by an external reset signal.
- Timer output controlled by two time constants
The timer output signal in each channel is controlled by two independent time constants, enabling the timer to generate output waveforms with an arbitrary duty factor.
- Three independent interrupts
Compare-match A and B and overflow interrupts can be requested independently.

8.1.2 Block Diagram

Figure 8.1 shows a block diagram of one channel in the 8-bit timer module. The other channel is identical.

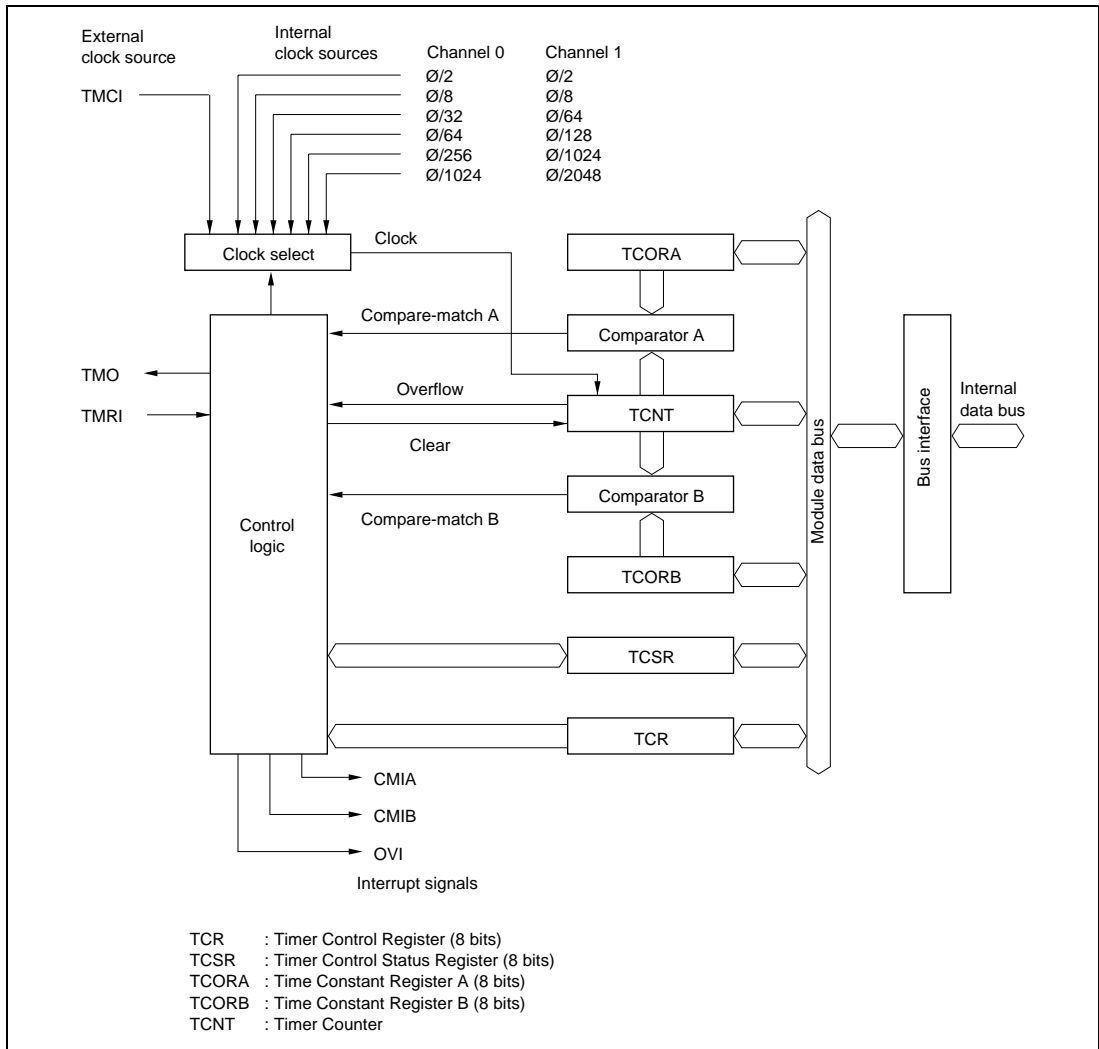

Figure 8.1 Block Diagram of 8-Bit Timer

8.1.3 Input and Output Pins

Table 8.1 lists the input and output pins of the 8-bit timer.

Table 8.1 Input and Output Pins of 8-Bit Timer

Name	Abbreviation		I/O	Function
	TMR0	TMR1		
Timer output	TMO ₀	TMO ₁	Output	Output controlled by compare-match
Timer clock input	TMCl ₀	TMCl ₁	Input	External clock source for the counter
Timer reset input	TMRI ₀	TMRI ₁	Input	External reset signal for the counter

8.1.4 Register Configuration

Table 8.2 lists the registers of the 8-bit timer module. Each channel has an independent set of registers.

Table 8.2 8-Bit Timer Registers

Name	Abbreviation	R/W	Initial Value	Address	
				TMR0	TMR1
Timer control register	TCR	R/W	H'00	H'FFC8	H'FFD0
Timer control/status register	TCSR	R/(W)*	H'10	H'FFC9	H'FFD1
Timer constant register A	TCORA	R/W	H'FF	H'FFCA	H'FFD2
Timer constant register B	TCORB	R/W	H'FF	H'FFCB	H'FFD3
Timer counter	TCNT	R/W	H'00	H'FFCC	H'FFD4
Serial/timer control register	STCR	R/W	H'F8	H'FFD0	H'FFC3

Note: Software can write a "0" to clear bits 7 to 5, but cannot write a "1" in these bits.

8.2 Register Descriptions

8.2.1 Timer Counter (TCNT)—H'FFCC (TMR0), H'FFD4 (TMR1)

Bit:	7	6	5	4	3	2	1	0
Initial value:	0	0	0	0	0	0	0	0
Read/Write:	R/W	R/W	R/W	R/W	R/W	R/W	R/W	R/W

Each timer counter (TCNT) is an 8-bit up-counter that increments on a pulse generated from an internal or external clock source selected by clock select bits 2 to 0 (CKS2 to CKS0) of the timer control register (TCR). The CPU can always read or write the timer counter.

The timer counter can be cleared by an external reset input or by an internal compare-match signal generated at a compare-match event. Clock clear bits 1 and 0 (CCLR1 and CCLR0) of the timer control register select the method of clearing.

When a timer counter overflows from H'FF to H'00, the overflow flag (OVF) in the timer control/status register (TCSR) is set to "1."

The timer counters are initialized to H'00 at a reset and in the standby modes.

8.2.2 Time Constant Registers A and B (TCORA and TCORB)—H'FFCA and H'FFCB (TMR0), H'FFD2 and H'FFD3 (TMR1)

Bit:	7	6	5	4	3	2	1	0
Initial value:	1	1	1	1	1	1	1	1
Read/Write:	R/W	R/W	R/W	R/W	R/W	R/W	R/W	R/W

TCORA and TCORB are 8-bit readable/writable registers. The timer count is continually compared with the constants written in these registers. When a match is detected, the corresponding compare-match flag (CMFA or CMFB) is set in the timer control/status register (TCSR).

The timer output signal (TMO0 or TMO1) is controlled by these compare-match signals as specified by output select bits 3 to 0 (OS3 to OS0) in the timer control/status register (TCSR).

TCORA and TCORB are initialized to H'FF at a reset and in the standby modes.

Compare-match is not detected during the T_3 state of a write cycle to TCORA or TCORB. See item (3) in section 8.6, “Application Notes.”

8.2.3 Timer Control Register (TCR)—H’FFC8 (TMR0), H’FFD0 (TMR1)

Bit:	7	6	5	4	3	2	1	0
	CMIEB	CMIEA	OVIE	CCLR1	CCLR0	CKS2	CKS1	CKS0
Initial value:	0	0	0	0	0	0	0	0
Read/Write:	R/W	R/W	R/W	R/W	R/W	R/W	R/W	R/W

Each TCR is an 8-bit readable/writable register that selects the clock source and the time at which the timer counter is cleared, and enables interrupts.

The TCRs are initialized to H’00 at a reset and in the standby modes.

For timing diagrams, see section 8.3, “Operation.”

Bit 7—Compare-match Interrupt Enable B (CMIEB): This bit selects whether to request compare-match interrupt B (CMIB) when compare-match flag B (CMFB) in the timer control/status register (TCSR) is set to “1.”

Bit 7

CMIEB	Description
0	Compare-match interrupt request B (CMIB) is disabled. (Initial value)
1	Compare-match interrupt request B (CMIB) is enabled.

Bit 6—Compare-match Interrupt Enable A (CMIEA): This bit selects whether to request compare-match interrupt A (CMIA) when compare-match flag A (CMFA) in the timer control/status register (TCSR) is set to “1.”

Bit 6

CMIEA	Description
0	Compare-match interrupt request A (CMIA) is disabled. (Initial value)
1	Compare-match interrupt request A (CMIA) is enabled.

Bit 5—Timer Overflow Interrupt Enable (OVIE): This bit selects whether to request a timer overflow interrupt (OVI) when the overflow flag (OVF) in the timer control/status register (TCSR) is set to “1.”

Bit 5 OVIE	Description	
0	The timer overflow interrupt request (OVI) is disabled.	(Initial value)
1	The timer overflow interrupt request (OVI) is enabled.	

Bits 4 and 3—Counter Clear 1 and 0 (CCLR1 and CCLR0): These bits select how the timer counter is cleared: by compare-match A or B or by an external reset input.

Bit 4 CCLR1	Bit 3 CCLR0	Description	
0	0	Not cleared.	(Initial value)
0	1	Cleared on compare-match A.	
1	0	Cleared on compare-match B.	
1	1	Cleared on rising edge of external reset input signal.	

Bits 2, 1, and 0—Clock Select (CKS2, CKS1, and CKS0): These bits and bits ICKS1 and ICKS0 in the serial/timer control register (STCR) select the internal or external clock source for the timer counter. Six internal clock sources, derived by prescaling the system clock, are available for each timer channel. For internal clock sources the counter is incremented on the falling edge of the internal clock. For an external clock source, these bits can select whether to increment the counter on the rising or falling edge of the clock input, or on both edges.

Channel	TCR			STCR		Description
	Bit 2 CKS2	Bit 1 CKS1	Bit 0 CKS0	Bit 1 ICKS1	Bit 0 ICKS0	
0	0	0	0	—	—	No clock source (timer stopped) (Initial value)
	0	0	1	—	0	$\phi/8$ internal clock, counted on falling edge
	0	0	1	—	1	$\phi/2$ internal clock, counted on falling edge
	0	1	0	—	0	$\phi/64$ internal clock, counted on falling edge
	0	1	0	—	1	$\phi/32$ internal clock, counted on falling edge
	0	1	1	—	0	$\phi/1024$ internal clock, counted on falling edge
	0	1	1	—	1	$\phi/256$ internal clock, counted on falling edge
	1	0	0	—	—	No clock source (timer stopped)
	1	0	1	—	—	External clock source, counted on rising edge
	1	1	0	—	—	External clock source, counted on falling edge
	1	1	1	—	—	External clock source, counted on both rising and falling edges
	1	0	0	0	—	—
0		0	1	0	—	$\phi/8$ internal clock, counted on falling edge
0		0	1	1	—	$\phi/2$ internal clock, counted on falling edge
0		1	0	0	—	$\phi/64$ internal clock, counted on falling edge
0		1	0	1	—	$\phi/128$ internal clock, counted on falling edge
0		1	1	0	—	$\phi/1024$ internal clock, counted on falling edge
0		1	1	1	—	$\phi/2048$ internal clock, counted on falling edge
1		0	0	—	—	No clock source (timer stopped)
1		0	1	—	—	External clock source, counted on rising edge
1		1	0	—	—	External clock source, counted on falling edge
1		1	1	—	—	External clock source, counted on both rising and falling edges

8.2.4 Timer Control/Status Register (TCSR)—H'FFC9 (TMR0), H'FFD1 (TMR1)

Bit:	7	6	5	4	3	2	1	0
	CMFB	CMFA	OVF	—	OS3	OS2	OS1	OS0
Initial value:	0	0	0	1	0	0	0	0
Read/Write:	R/(W)*	R/(W)*	R/(W)*	—	R/W	R/W	R/W	R/W

Note: Software can write a “0” in bits 7 to 5 to clear the flags, but cannot write a “1” in these bits.

The TCSR is an 8-bit readable and partially writable register that indicates compare-match and overflow status and selects the effect of compare-match events on the timer output signal.

The TCSR is initialized to H'10 at a reset and in the standby modes.

Bit 7—Compare-Match Flag B (CMFB): This status flag is set to “1” when the timer count matches the time constant set in TCORB. CMFB must be cleared by software. It is set by hardware, however, and cannot be set by software.

Bit 7

CMFB	Description
0	To clear CMFB, the CPU must read CMFB after it has been set to “1,” (Initial value) then write a “0” in this bit.
1	This bit is set to 1 when TCNT = TCORB.

Bit 6—Compare-Match Flag A (CMFA): This status flag is set to “1” when the timer count matches the time constant set in TCORA. CMFA must be cleared by software. It is set by hardware, however, and cannot be set by software.

Bit 6

CMFA	Description
0	To clear CMFA, the CPU must read CMFA after it has been set to “1,” (Initial value) then write a “0” in this bit.
1	This bit is set to 1 when TCNT = TCORA.

Bit 5—Timer Overflow Flag (OVF): This status flag is set to “1” when the timer count overflows (changes from H'FF to H'00). OVF must be cleared by software. It is set by hardware, however, and cannot be set by software.

Bit 5 OVF	Description
0	To clear OVF, the CPU must read OVF after it has been set to “1,” then write a “0” in this bit. (Initial value)
1	This bit is set to 1 when TCNT changes from H'FF to H'00.

Bit 4—Reserved: This bit is always read as “1.” It cannot be written.

Bits 3 to 0—Output Select 3 to 0 (OS3 to OS0): These bits specify the effect of compare-match events on the timer output signal (TCOR or TCNT). Bits OS3 and OS2 control the effect of compare-match B on the output level. Bits OS1 and OS0 control the effect of compare-match A on the output level.

If compare-match A and B occur simultaneously, any conflict is resolved as explained in item (4) in section 8.6, “Application Notes.”

After a reset, the timer output is “0” until the first compare-match event.

When all four output select bits are cleared to “0” the timer output signal is disabled.

Bit 3 OS3	Bit 2 OS2	Description
0	0	No change when compare-match B occurs. (Initial value)
0	1	Output changes to “0” when compare-match B occurs.
1	0	Output changes to “1” when compare-match B occurs.
1	1	Output inverts (toggles) when compare-match B occurs.

Bit 1 OS1	Bit 0 OS0	Description
0	0	No change when compare-match A occurs. (Initial value)
0	1	Output changes to “0” when compare-match A occurs.
1	0	Output changes to “1” when compare-match A occurs.
1	1	Output inverts (toggles) when compare-match A occurs.

8.2.5 Serial/Timer Control Register (STCR)—H'FFC3

Bit:	7	6	5	4	3	2	1	0
	—	—	—	—	—	MPE	ICKS1	ICKS0
Initial value:	1	1	1	1	1	0	0	0
Read/Write:	—	—	—	—	—	R/W	R/W	R/W

The STCR is an 8-bit readable/writable register that controls the serial communication interface and selects internal clock sources for the timer counters.

The STCR is initialized to HF8 at a reset.

Bits 7 to 3—Reserved: These bits cannot be modified and are always read as “1.”

Bit 2—Multiprocessor Enable (MPE): Controls the operating mode of serial communication interfaces 0 and 1. For details, see section 9, “Serial Communication Interface.”

Bits 1 and 0—Internal Clock Source Select 1 and 0 (ICKS1 and ICKS0): These bits and bits CKS2 to CKS0 in the TCR select clock sources for the timer counters. For details, see section 8.2.3, “Timer Control Register.”

8.3 Operation

8.3.1 TCNT Incrementation Timing

The timer counter increments on a pulse generated once for each period of the selected (internal or external) clock source.

Internal Clock: Internal clock sources are created from the system clock by a prescaler. The counter increments on an internal TCNT clock pulse generated from the falling edge of the prescaler output, as shown in figure 8.2. Bits CKS2 to CKS0 of the TCR and bits ICKS1 and ICKS0 of the STCR can select one of the six internal clocks.

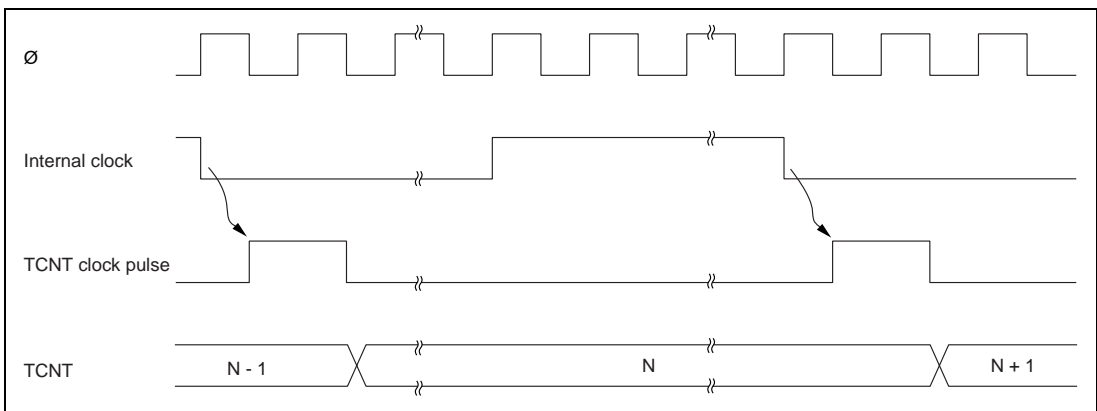

Figure 8.2 Count Timing for Internal Clock Input

External Clock: If external clock input (TMCI) is selected, the timer counter can increment on the rising edge, the falling edge, or both edges of the external clock signal. Figure 8.3 shows incrementation on both edges of the external clock signal.

The external clock pulse width must be at least 1.5 system clock periods for incrementation on a single edge, and at least 2.5 system clock periods for incrementation on both edges. See figure 8.4. The counter will not increment correctly if the pulse width is shorter than these values.

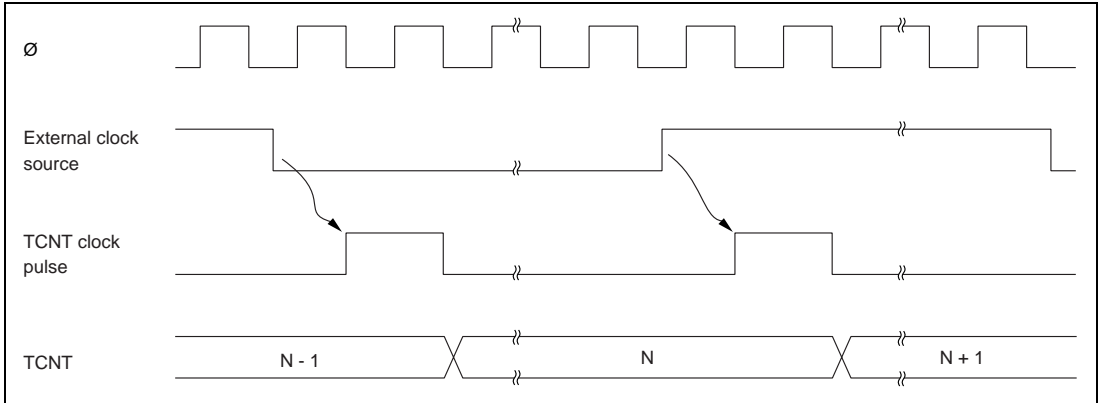

Figure 8.3 Count Timing for External Clock Input

8.3.2 Compare Match Timing

(1) Setting of Compare-Match Flags A and B (CMFA and CMFB): The compare-match flags are set to “1” by an internal compare-match signal generated when the timer count matches the time constant in TCNT or TCOR. The compare-match signal is generated at the last state in which the match is true, just before the timer counter increments to a new value.

Accordingly, when the timer count matches one of the time constants, the compare-match signal is not generated until the next period of the clock source. Figure 8.4 shows the timing of the setting of the compare-match flags.

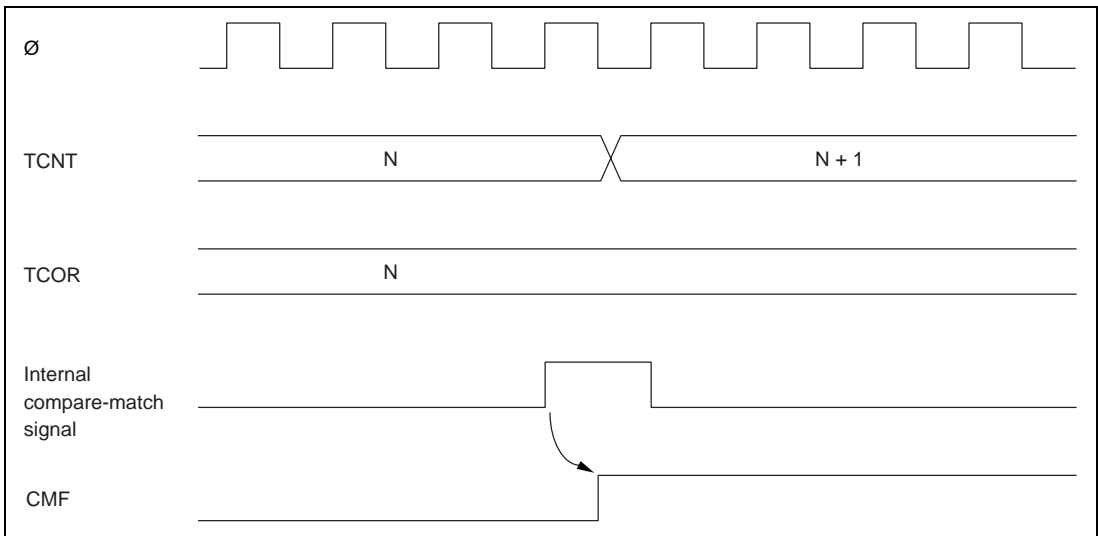

Figure 8.4 Setting of Compare-Match Flags

(2) Output Timing: When a compare-match event occurs, the timer output (TMO0 or TMO1) changes as specified by the output select bits (OS3 to OS0) in the TCSR. Depending on these bits, the output can remain the same, change to “0,” change to “1,” or toggle.

Figure 8.5 shows the timing when the output is set to toggle on compare-match A.

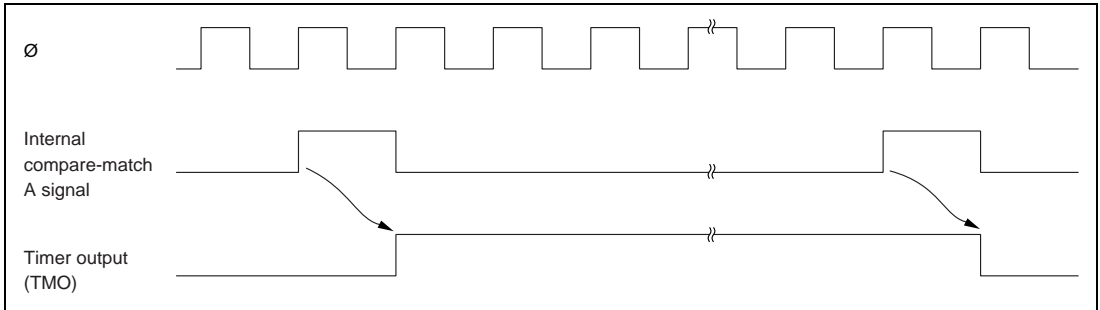

Figure 8.5 Timing of Timer Output

(3) Timing of Compare-Match Clear: Depending on the CCLR1 and CCLR0 bits in the TCR, the timer counter can be cleared when compare-match A or B occurs. Figure 8.6 shows the timing of this operation.

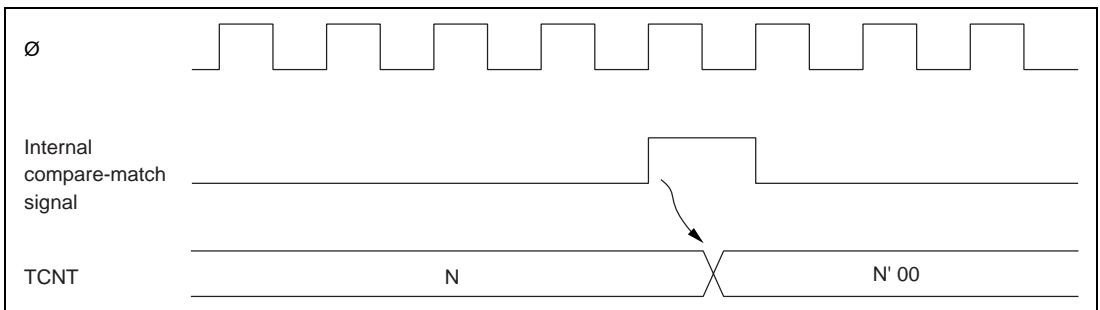

Figure 8.6 Timing of Compare-Match Clear

8.3.3 External Reset of TCNT

When the CCLR1 and CCLR0 bits in the TCR are both set to “1,” the timer counter is cleared on the rising edge of an external reset input. Figure 8.7 shows the timing of this operation. The timer reset pulse width must be at least 1.5 system clock periods.

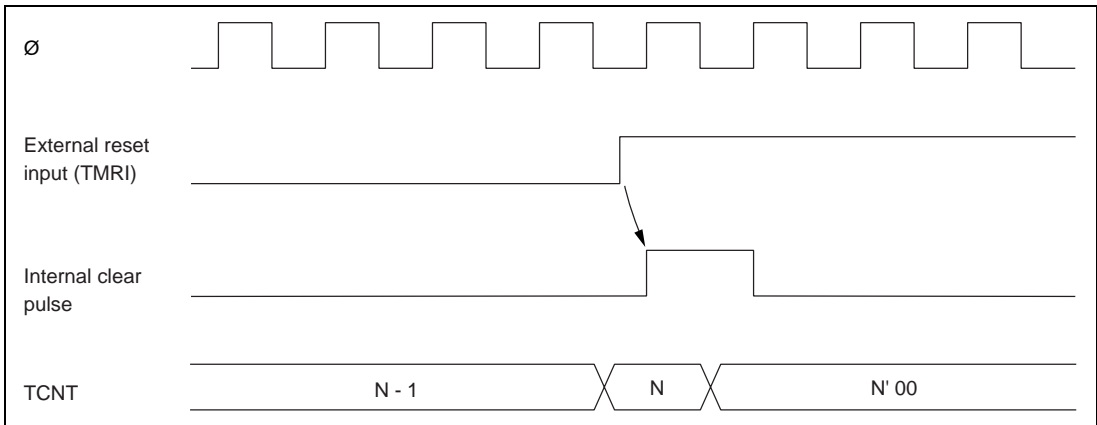

Figure 8.7 Timing of External Reset

8.3.4 Setting of TCSR Overflow Flag (OVF)

The overflow flag (OVF) is set to “1” when the timer count overflows (changes from H'FF to H'00). Figure 8.8 shows the timing of this operation.

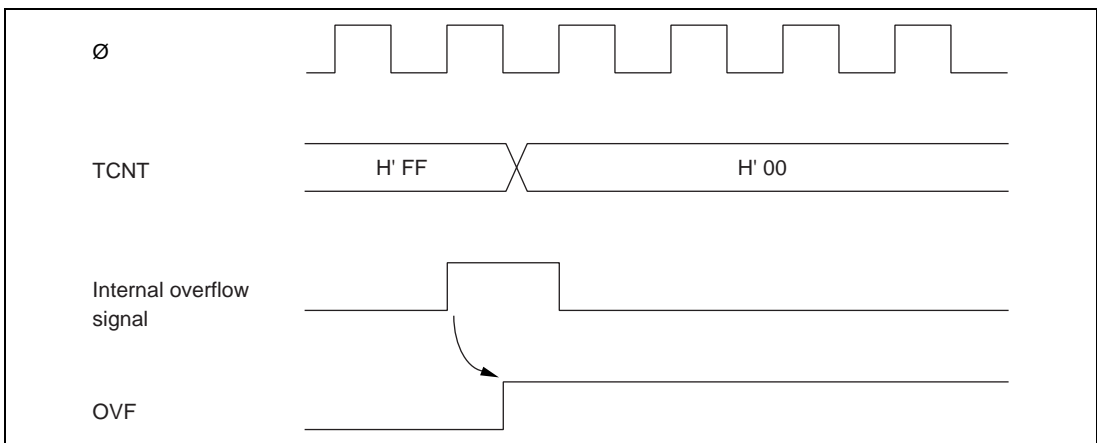

Figure 8.8 Setting of Overflow Flag (OVF)

8.4 Interrupts

Each channel in the 8-bit timer can generate three types of interrupts: compare-match A and B (CMIA and CMIB), and overflow (OVI). Each interrupt is requested when the corresponding enable bits are set in the TCR and TCSR. Independent signals are sent to the interrupt controller for each interrupt. Table 8.3 lists information about these interrupts.

Table 8.3 8-Bit Timer Interrupts

Interrupt	Description	Priority
CMIA	Requested when CMFA and CMIEA are set	High
CMIB	Requested when CMFB and CMIEB are set	↕
OVI	Requested when OVF and OVIE are set	Low

8.5 Sample Application

In the example below, the 8-bit timer is used to generate a pulse output with a selected duty cycle. The control bits are set as follows:

- (1) In the TCR, CCLR1 is cleared to “0” and CCLR0 is set to “1” so that the timer counter is cleared when its value matches the constant in TCORA.
- (2) In the TCSR, bits OS3 to OS0 are set to “0110,” causing the output to change to “1” on compare-match A and to “0” on compare-match B.

With these settings, the 8-bit timer provides output of pulses at a rate determined by TCORA with a pulse width determined by TCORB. No software intervention is required.

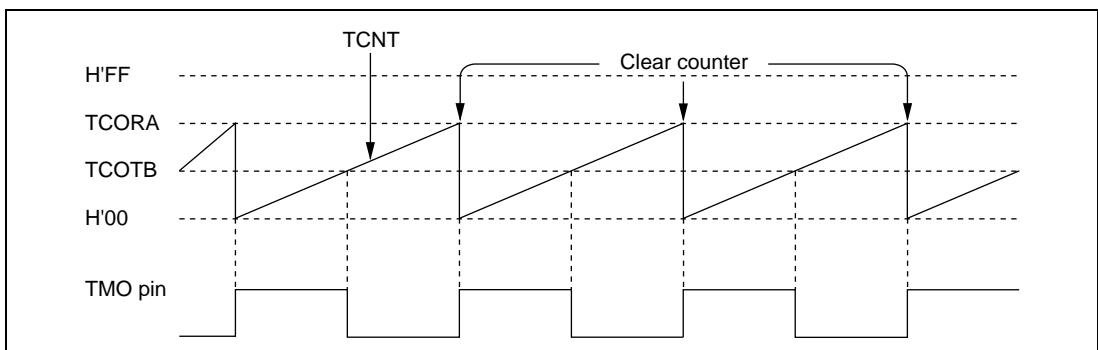

Figure 8.9 Example of Pulse Output

8.6 Application Notes

Application programmers should note that the following types of contention can occur in the 8-bit timer.

(1) Contention between TCNT Write and Clear: If an internal counter clear signal is generated during the T_3 state of a write cycle to the timer counter, the clear signal takes priority and the write is not performed.

Figure 8.10 shows this type of contention.

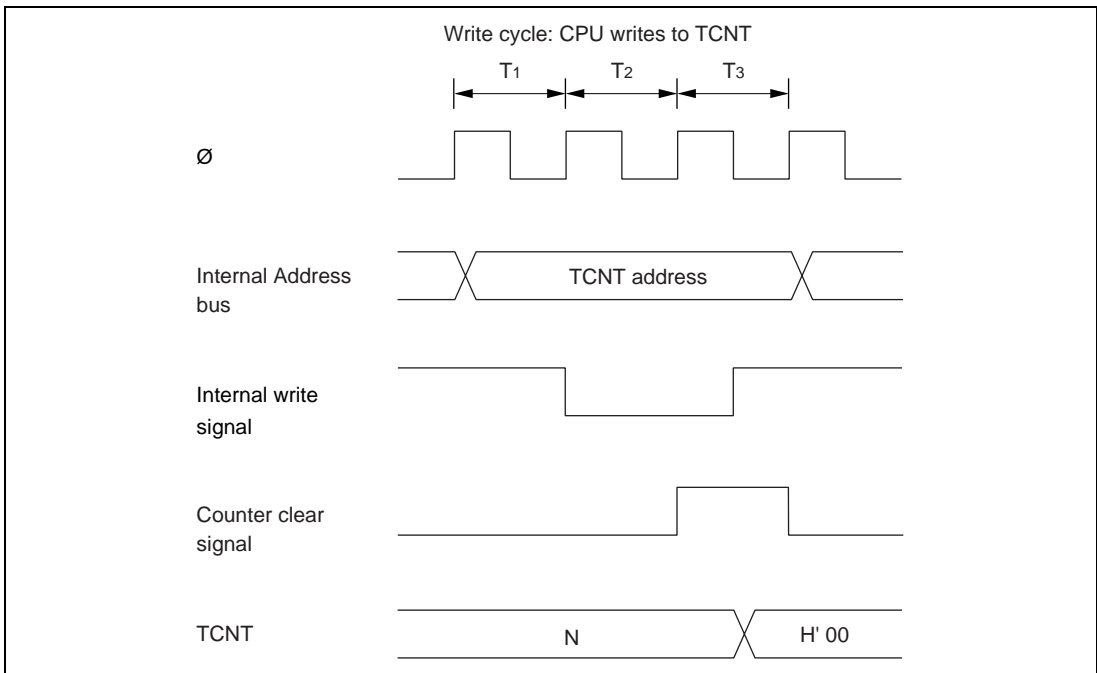

Figure 8.10 TCNT Write-Clear Contention

(2) Contention between TCNT Write and Increment: If a timer counter increment pulse is generated during the T₃ state of a write cycle to the timer counter, the write takes priority and the timer counter is not incremented.

Figure 8.11 shows this type of contention.

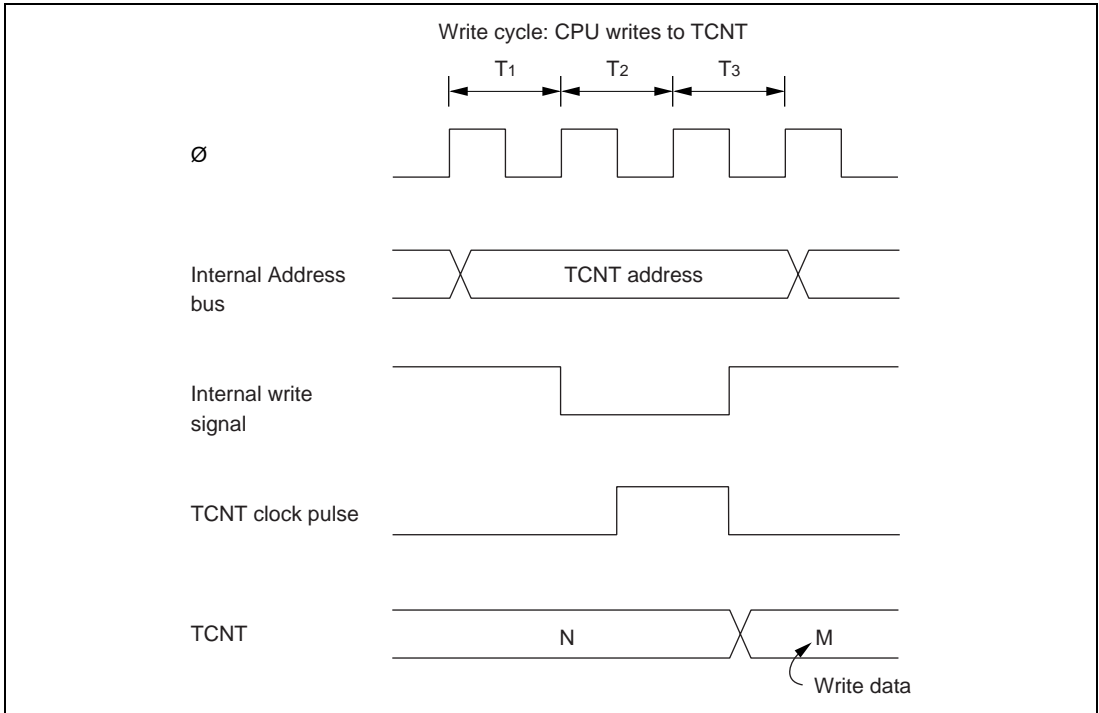

Figure 8.11 TCNT Write-Increment Contention

(3) Contention between TCOR Write and Compare-Match: If a compare-match occurs during the T₃ state of a write cycle to TCORA or TCORB, the write takes precedence and the compare-match signal is inhibited.

Figure 8.12 shows this type of contention.

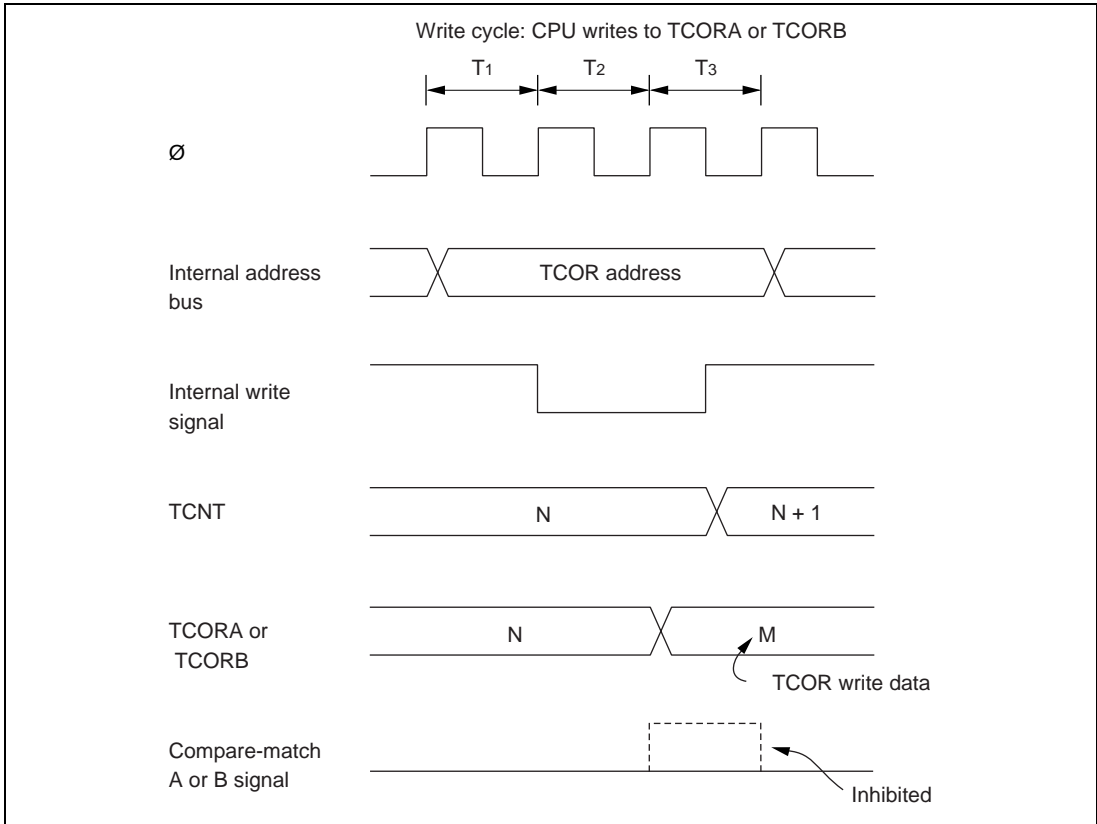

Figure 8.12 Contention between TCOR Write and Compare-Match

(4) Contention between Compare-Match A and Compare-Match B: If identical time constants are written in TCORA and TCORB, causing compare-match A and B to occur simultaneously, any conflict between the output selections for compare-match A and B is resolved by following the priority order in table 8.4.

Table 8.4 Priority of Timer Output

Output Selection	Priority
Toggle	High
"1" Output	↑
"0" Output	
No change	Low

(5) Incrementation Caused by Changing of Internal Clock Source: When an internal clock source is changed, the changeover may cause the timer counter to increment. This depends on the time at which the clock select bits (CKS1, CKS0) are rewritten, as shown in table 8.5.

The pulse that increments the timer counter is generated at the falling edge of the internal clock source signal. If clock sources are changed when the old source is High and the new source is Low, as in case No. 3 in table 8.5, the changeover generates a falling edge that triggers the TCNT clock pulse and increments the timer counter.

Switching between an internal and external clock source can also cause the timer counter to increment.

Table 8.5 Effect of Changing Internal Clock Sources

No.	Description	Timing chart
1	<p>Low → Low*¹: Clock select bits are rewritten while both clock sources are Low.</p>	<p>Old clock source</p> <p>New clock source</p> <p>TCNT clock pulse</p> <p>TCNT</p> <p>CKS rewrite</p>
2	<p>Low → High*²: Clock select bits are rewritten while old clock source is Low and new clock source is High.</p>	<p>Old clock source</p> <p>New clock source</p> <p>TCNT clock pulse</p> <p>TCNT</p> <p>CKS rewrite</p>

Notes: 1. Including a transition from Low to the stopped state (CKS1 = 0, CKS0 = 0), or a transition from the stopped state to Low.

2. Including a transition from the stopped state to High.

Table 8.5 Effect of Changing Internal Clock Sources (cont)

No.	Description	Timing chart
3	<p>High → Low*¹: Clock select bits are rewritten while old clock source is High and new clock source is Low.</p>	
4	<p>High → High: Clock select bits are rewritten while both clock sources are High.</p>	

Notes: 1. Including a transition from High to the stopped state.
 2. The switching of clock sources is regarded as a falling edge that increments the TCNT.

Section 9 PWM Timers

9.1 Overview

The H8/338 Series has an on-chip pulse-width modulation (PWM) timer module with two independent channels (PWM0 and PWM1). Both channels are functionally identical. Each PWM channel generates a rectangular output pulse with a duty cycle of 0 to 100%. The duty cycle is specified in an 8-bit duty register (DTR).

9.1.1 Features

The PWM timer module has the following features:

- Selection of eight clock sources
- Duty cycles from 0 to 100% with 1/250 resolution
- Output with positive or negative logic and software enable/disable control

9.1.2 Block Diagram

Figure 9.1 shows a block diagram of one PWM timer channel.

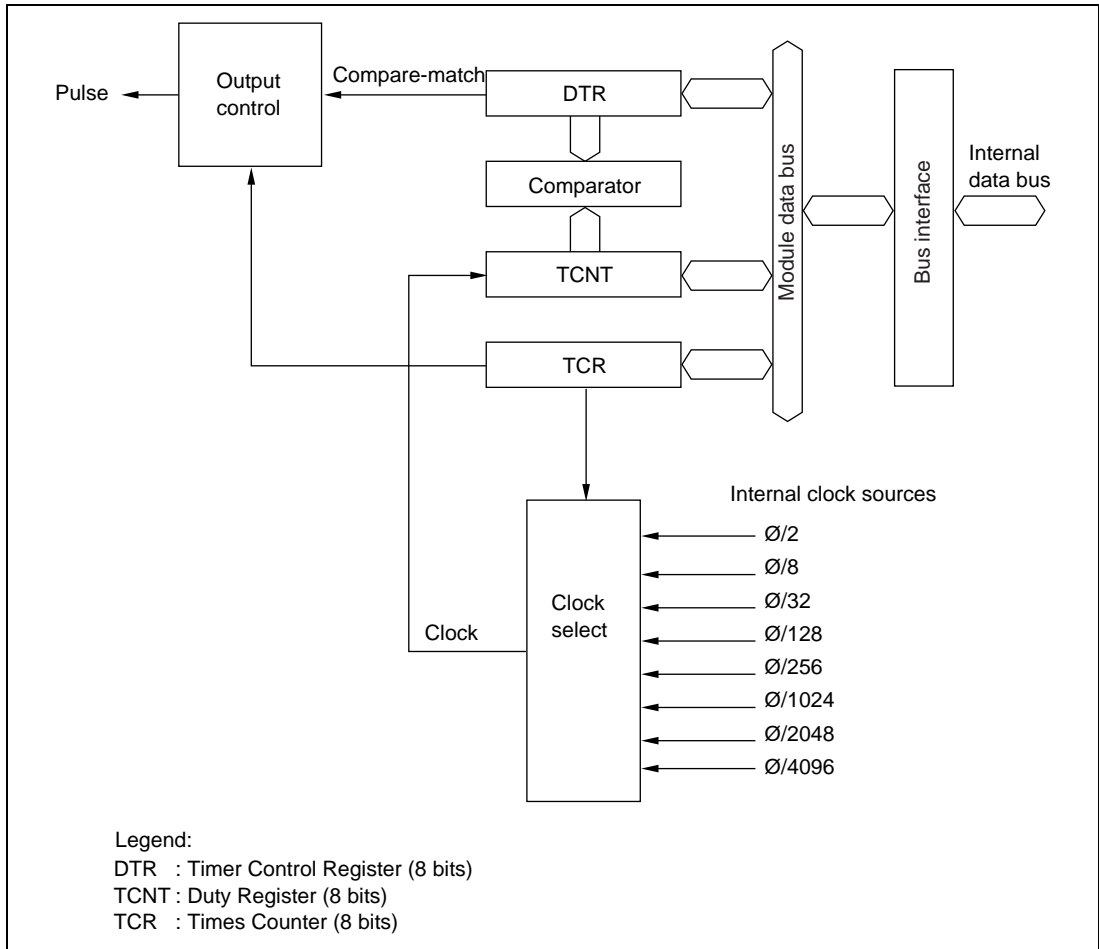

Figure 9.1 Block Diagram of PWM Timer

9.1.3 Input and Output Pins

Table 9.1 lists the output pins of the PWM timer module. There are no input pins.

Table 9.1 Output Pins of PWM Timer Module

Name	Abbreviation	I/O	Function
PWM0 output	PW0	Output	Pulse output from PWM timer channel 0.
PWM1 output	PW1	Output	Pulse output from PWM timer channel 1.

9.1.4 Register Configuration

The PWM timer module has three registers for each channel as listed in table 9.2.

Table 9.2 PWM Timer Registers

Name	Abbreviation	R/W	Initial Value	Address	
				PWM0	PWM1
Timer control register	TCR	R/W	H'38	H'FFA0	H'FFA4
Duty register	DTR	R/W	H'FF	H'FFA1	H'FFA5
Timer counter	TCNT	R/W	H'00	H'FFA2	H'FFA6

9.2 Register Descriptions

9.2.1 Timer Counter (TCNT)—H'FFA2 (PWM0), H'FFA6 (PWM1)

Bit:	7	6	5	4	3	2	1	0
Initial value:	0	0	0	0	0	0	0	0
Read/Write:	R/W	R/W	R/W	R/W	R/W	R/W	R/W	R/W

The PWM timer counters (TCNT) are 8-bit up-counters. When the output enable bit (OE) in the timer control register (TCR) is set to “1,” the timer counter starts counting pulses of an internal clock source selected by clock select bits 2 to 0 (CKS2 to CKS0). After counting from H'00 to H'F9, the timer counter repeats from H'00.

The PWM timer counters are initialized to H'00 at a reset and in the standby modes, and when the OE bit is cleared to “0.”

9.2.2 Duty Register (DTR)—H'FFA1 (PWM0), H'FFA5 (PWM1)

Bit:	7	6	5	4	3	2	1	0
Initial value:	1	1	1	1	1	1	1	1
Read/Write:	R/W	R/W	R/W	R/W	R/W	R/W	R/W	R/W

The duty registers (DTR) are 8-bit readable/writable registers that specify the duty cycle of the output pulse. Any duty cycle from 0 to 100% can be selected, with a resolution of 1/250. Writing 0 (H'00) in a DTR gives a 0% duty cycle; writing 125 (H'7D) gives a 50% duty cycle; writing 250 (H'FA) gives a 100% duty cycle.

The timer count is continually compared with the DTR contents. If the DTR value is not 0, when the count increments from H'00 to H'01 the PWM output signal is set to “1.” When the count increments past the DTR value, the PWM output returns to “0.” If the DTR value is 0 (0% duty), the PWM output remains constant at “0.”

The DTRs are double-buffered. A new value written in a DTR while the timer counter is running does not become valid until after the count changes from H'F9 to H'00. When the timer counter is stopped (while the OE bit is “0”), new values become valid as soon as written. When a DTR is read, the value read is the currently valid value.

The DTRs are initialized to H'FF at a reset and in the standby modes.

9.2.3 Timer Control Register (TCR)—H'FFA0 (PWM0), H'FFA4 (PWM1)

Bit:	7	6	5	4	3	2	1	0
	OE	OS	—	—	—	CKS2	CKS1	CKS0
Initial value:	0	0	1	1	1	0	0	0
Read/Write:	R/W	R/W	—	—	—	R/W	R/W	R/W

The TCRs are 8-bit readable/writable registers that select the clock source and control the PWM outputs.

The TCRs are initialized to H'38 at a reset and in the standby modes.

Bit 7—Output Enable (OE): This bit enables the timer counter and the PWM output.

Bit 7

OE	Description
0	PWM output is disabled. TCNT is cleared to H'00 and stopped. (Initial value)
1	PWM output is enabled. TCNT runs.

Bit 6—Output Select (OS): This bit selects positive or negative logic for the PWM output.

Bit 6

OS	Description
0	Positive logic; positive-going PWM pulse, “1” = High (Initial value)
1	Negative logic; negative-going PWM pulse, “1” = Low

Bits 5 to 3—Reserved: These bits cannot be modified and are always read as “1.”

Bits 2, 1, and 0—Clock Select (CKS2, CKS1, and CKS0): These bits select one of eight internal clock sources obtained by dividing the system clock (ϕ).

Bit 2 CKS2	Bit 1 CKS1	Bit 0 CKS0	Description
0	0	0	$\phi/2$ (Initial value)
0	0	1	$\phi/8$
0	1	0	$\phi/32$
0	1	1	$\phi/128$
1	0	0	$\phi/256$
1	0	1	$\phi/1024$
1	1	0	$\phi/2048$
1	1	1	$\phi/4096$

From the clock source frequency, the resolution, period, and frequency of the PWM output can be calculated as follows.

$$\text{Resolution} = 1/\text{clock source frequency}$$

$$\text{PWM period} = \text{resolution} \times 250$$

$$\text{PWM frequency} = 1/\text{PWM period}$$

If the system clock frequency is 10MHz, then the resolution, period, and frequency of the PWM output for each clock source are given in table 9.3.

Table 9.3 PWM Timer Parameters for 10MHz System Clock

Internal Clock Frequency	Resolution	PWM Period	PWM Frequency
$\phi/2$	200ns	50 μ s	20kHz
$\phi/8$	800ns	200 μ s	5kHz
$\phi/32$	3.2 μ s	800 μ s	1.25kHz
$\phi/128$	12.8 μ s	3.2ms	312.5Hz
$\phi/256$	25.6 μ s	6.4ms	156.3Hz
$\phi/1024$	102.4 μ s	25.6ms	39.1Hz
$\phi/2048$	204.8 μ s	51.2ms	19.5Hz
$\phi/4096$	409.6 μ s	102.4ms	9.8Hz

9.3 Operation

9.3.1 Timer Incrementation

The PWM clock source is created from the system clock (ϕ) by a prescaler. The timer counter increments on a TCNT clock pulse generated from the falling edge of the prescaler output as shown in figure 9.2.

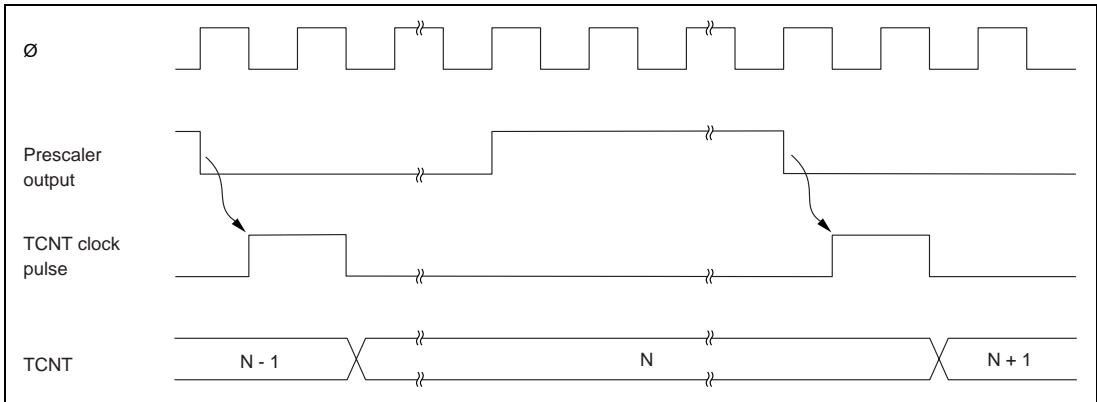

Figure 9.2 TCNT Increment Timing

9.3.2 PWM Operation

Figure 9.3 is a timing chart of the PWM operation.

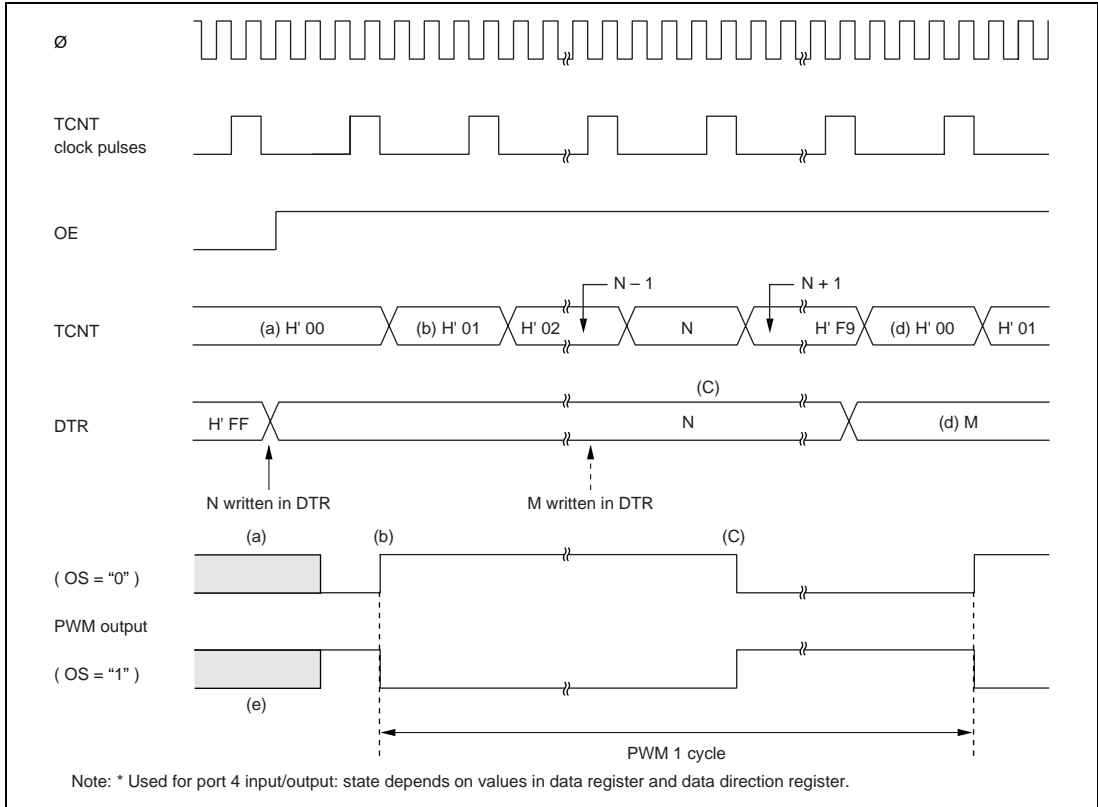

Figure 9.3 PWM Timing

(1) Positive Logic (OS = "0")

① **When (OE = "0") – (a) in Figure 9.3:** The timer count is held at H'00 and PWM output is inhibited. [Pin 4₆ (for PW0) or pin 4₇ (for PW1) is used for port 4 input/output, and its state depends on the corresponding port 4 data register and data direction register.] Any value (such as N in figure 9.3) written in the DTR becomes valid immediately.

② When (OE = "1")

- i) The timer counter begins incrementing. The PWM output goes High when TCNT changes from H'00 to H'01, unless DTR = H'00. [(b) in figure 9.3]
- ii) When the count passes the DTR value, the PWM output goes Low. [(c) in figure 9.3]

iii) If the DTR value is changed (by writing the data “M” in figure 9.3), the new value becomes valid after the timer count changes from H'F9 to H'00. [(d) in figure 9.3]

(2) **Negative Logic (OS = “1”) - (e) in Figure 9.3:** The operation is the same except that High and Low are reversed in the PWM output. [(e) in figure 9.3]

9.4 Application Notes

Some notes on the use of the PWM timer module are given below.

(1) Any necessary changes to the clock select bits (CKS2 to CKS0) and output select bit (OS) should be made before the output enable bit (OE) is set to “1.”

(2) If the DTR value is H'00, the duty cycle is 0% and PWM output remains constant at “0.”

If the DTR value is H'FA to H'FF, the duty cycle is 100% and PWM output remains constant at “1.”

(For positive logic, “0” is Low and “1” is High. For negative logic, “0” is High and “1” is Low.)

Section 10 Serial Communication Interface

10.1 Overview

The H8/338 Series includes two serial communication interface channels (SCI0 and SCI1) for transferring serial data to and from other chips. Either synchronous or asynchronous communication can be selected.

10.1.1 Features

The features of the on-chip serial communication interface are:

- Asynchronous mode

The H8/338 Series can communicate with a UART (Universal Asynchronous Receiver/Transmitter), ACIA (Asynchronous Communication Interface Adapter), or other chip that employs standard asynchronous serial communication. It also has a multiprocessor communication function for communication with other processors. Twelve data formats are available.

- Data length: 7 or 8 bits

- Stop bit length: 1 or 2 bits

- Parity: Even, odd, or none

- Multiprocessor bit: “1” or “0”

- Error detection: Parity, overrun, and framing errors

- Break detection: When a framing error occurs, the break condition can be detected by reading the level of the RxD line directly.

- Synchronous mode

The SCI can communicate with chips able to perform clocked synchronous data transfer.

- Data length: 8 bits

- Error detection: Overrun errors

- Full duplex communication

The transmitting and receiving sections are independent, so each channel can transmit and receive simultaneously. Both the transmit and receive sections use double buffering, so continuous data transfer is possible in either direction.

- Built-in baud rate generator

Any specified baud rate can be generated.

- Internal or external clock source

The SCI can operate on an internal clock signal from the baud rate generator, or an external clock signal input at the SCK0 or SCK1 pin.

- Four interrupts

TDR-empty, TSR-empty, receive-end, and receive-error interrupts are requested independently.

10.1.2 Block Diagram

Figure 10.1 shows a block diagram of one serial communication interface channel.

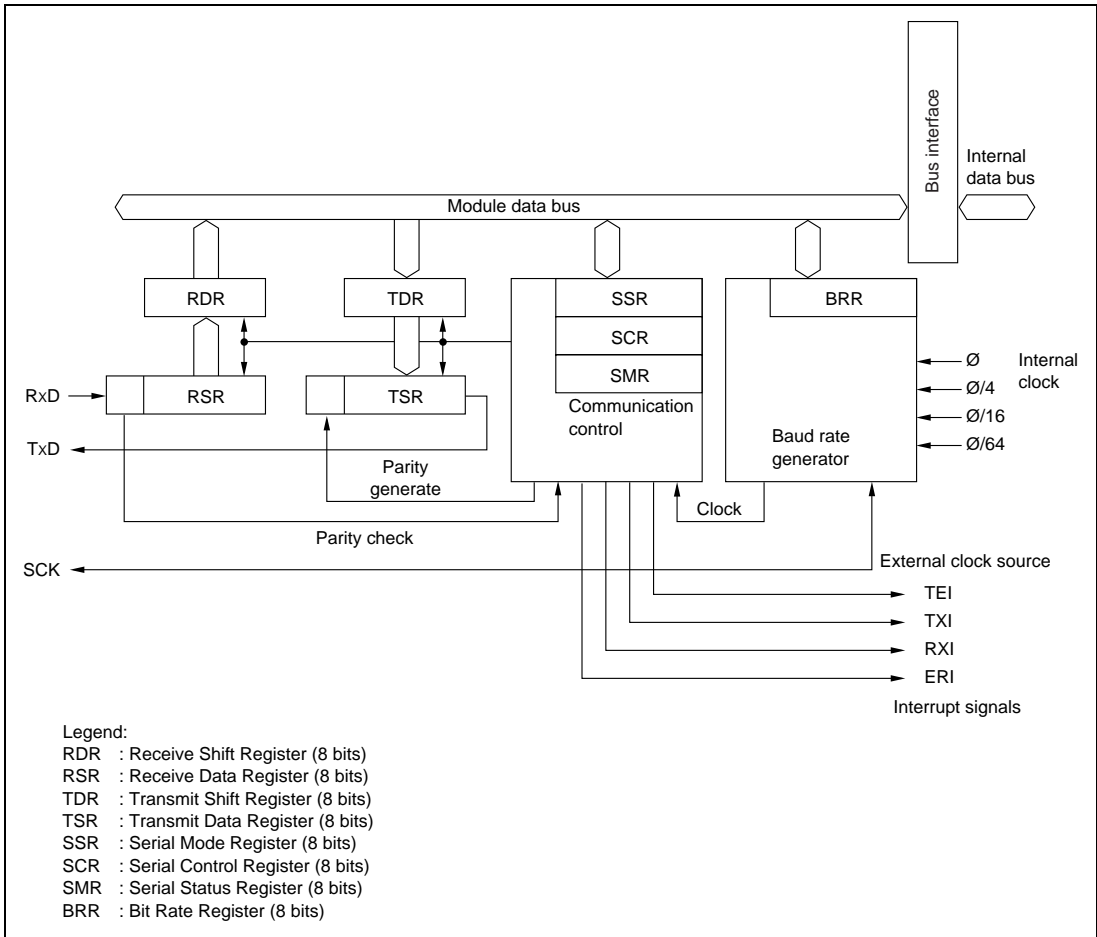

Figure 10.1 Block Diagram of Serial Communication Interface

10.1.3 Input and Output Pins

Table 10.1 lists the input and output pins used by the SCI module.

Table 10.1 SCI Input/Output Pins

Channel	Name	Abbr.	I/O	Function
0	Serial clock	SCK ₀	Input/output	Serial clock input and output.
	Receive data	RxD ₀	Input	Receive data input.
	Transmit data	TxD ₀	Output	Transmit data output.
1	Serial clock	SCK ₁	Input/output	Serial clock input and output.
	Receive data	RxD ₁	Input	Receive data input.
	Transmit data	TxD ₁	Output	Transmit data output.

10.1.4 Register Configuration

Table 10.2 lists the SCI registers. These registers specify the operating mode (synchronous or asynchronous), data format and bit rate, and control the transmit and receive sections.

Table 10.2 SCI Registers

Channel	Name	Abbr.	R/W	Value	Address
0	Receive shift register	RSR	—	—	—
	Receive data register	RDR	R	H'00	H'FFDD
	Transmit shift register	TSR	—	—	—
	Transmit data register	TDR	R/W	H'FF	H'FFDB
	Serial mode register	SMR	R/W	H'00	H'FFD8
	Serial control register	SCR	R/W	H'00	H'FFDA
	Serial status register	SSR	R/(W)*	H'84	H'FFDC
	Bit rate register	BRR	R/W	H'FF	H'FFD9
1	Receive shift register	RSR	—	—	—
	Receive data register	RDR	R	H'00	H'FF8D
	Transmit shift register	TSR	—	—	—
	Transmit data register	TDR	R/W	H'FF	H'FF8B
	Serial mode register	SMR	R/W	H'00	H'FF88
	Serial control register	SCR	R/W	H'00	H'FF8A
	Serial status register	SSR	R/(W)*	H'84	H'FF8C
	Bit rate register	BRR	R/W	H'FF	H'FF89
0 and 1	Serial/timer control register	STCR	R/W	H'F8	H'FFC3

Note: Software can write a “0” to clear the flags in bits 7 to 3, but cannot write “1” in these bits.

10.2 Register Descriptions

10.2.1 Receive Shift Register (RSR)

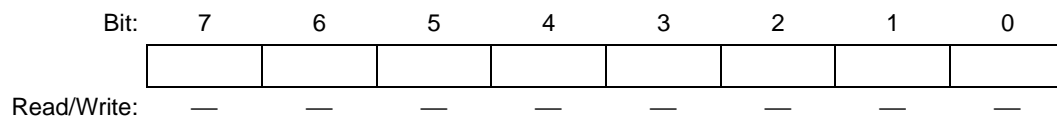

The RSR is a shift register that converts incoming serial data to parallel data. When one data character has been received, it is transferred to the receive data register (RDR).

The CPU cannot read or write the RSR directly.

10.2.2 Receive Data Register (RDR)—H'FFDD, H'FF8D

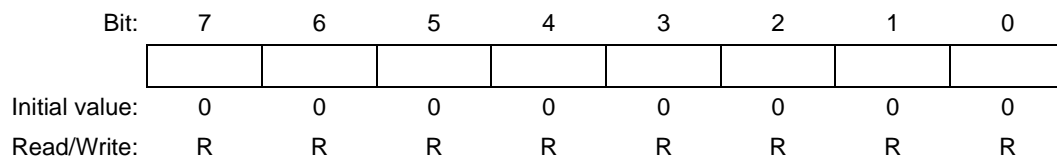

The RDR stores received data. As each character is received, it is transferred from the RSR to the RDR, enabling the RSR to receive the next character. This double-buffering allows the SCI to receive data continuously.

The CPU can read but not write the RDR. The RDR is initialized to H'00 at a reset and in the standby modes.

10.2.3 Transmit Shift Register (TSR)

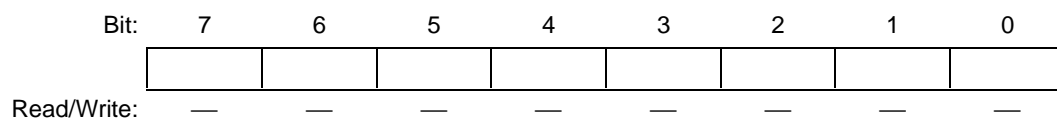

The TSR is a shift register that converts parallel data to serial transmit data. When transmission of this character is completed, the next character is moved from the transmit data register (TDR) to the TSR and transmission of that character begins. If the TDRE bit is still set to "1", however, nothing is transferred to the TSR.

The CPU cannot read or write the TSR directly.

10.2.4 Transmit Data Register (TDR)—H'FFDB, H'FF8B

Bit:	7	6	5	4	3	2	1	0
Initial value:	1	1	1	1	1	1	1	1
Read/Write:	R/W	R/W	R/W	R/W	R/W	R/W	R/W	R/W

The TDR is an 8-bit readable/writable register that holds the next character to be transmitted. When the TSR becomes empty, the character written in the TDR is transferred to the TSR. Continuous data transmission is possible by writing the next byte in the TDR while the current byte is being transmitted from the TSR.

The TDR is initialized to H'FF at a reset and in the standby modes.

10.2.5 Serial Mode Register (SMR)—H'FFD8, H'FF88

Bit:	7	6	5	4	3	2	1	0
	C/ \bar{A}	CHR	PE	O/ \bar{E}	STOP	MP	CKS1	CKS0
Initial value:	1	0	0	0	0	0	0	0
Read/Write:	R/W	R/W	R/W	R/W	R/W	R/W	R/W	R/W

The SMR is an 8-bit readable/writable register that controls the communication format and selects the clock rate for the internal clock source. It is initialized to H'00 at a reset and in the standby modes. For further information on the SMR settings and communication formats, see tables 10.5 and 10.7 in section 10.3, "Operation."

Bit 7—Communication Mode (C/ \bar{A}): This bit selects the asynchronous or clocked synchronous communication mode.

Bit 7

C/ \bar{A}	Description
0	Asynchronous communication. (Initial value)
1	Clocked synchronous communication.

Bit 6—Character Length (CHR): This bit selects the character length in asynchronous mode. It is ignored in synchronous mode.

Bit 6 CHR	Description	
0	8 bits per character.	(Initial value)
1	7 bits per character. (Bits 0 to 6 of TDR and RDR are used for transmitting and receiving, respectively.)	

Bit 5—Parity Enable (PE): This bit selects whether to add a parity bit in asynchronous mode. It is ignored in synchronous mode, and when a multiprocessor format is used.

Bit 5 PE	Description	
0	Transmit: No parity bit is added. Receive: Parity is not checked.	(Initial value)
1	Transmit: A parity bit is added. Receive: Parity is checked.	

Bit 4—Parity Mode (O/\bar{E}): In asynchronous mode, when parity is enabled (PE = “1”), this bit selects even or odd parity.

Even parity means that a parity bit is added to the data bits for each character to make the total number of 1’s even. Odd parity means that the total number of 1’s is made odd.

This bit is ignored when PE = “0,” or when a multiprocessor format is used. It is also ignored in the synchronous mode.

Bit 4 O/\bar{E}	Description	
0	Even parity.	(Initial value)
1	Odd parity.	

Bit 3—Stop Bit Length (STOP): This bit selects the number of stop bits. It is ignored in the synchronous mode.

Bit 3

STOP	Description	
0	One stop bit. Transmit: One stop bit is added. Receive: One stop bit is checked to detect framing errors.	(Initial value)
1	Two stop bits. Transmit: Two stop bits are added. Receive: The first stop bit is checked to detect framing errors. If the second stop bit is a space (0), it is regarded as the next start bit.	

Bit 2—Multiprocessor Mode (MP): This bit selects the multiprocessor format in asynchronous communication. When multiprocessor format is selected, the parity settings of the parity enable bit (PE) and parity mode bit (O/E) are ignored. The MP bit is ignored in synchronous communication.

The MP bit is valid only when the MPE bit in the serial/timer control register (STCR) is set to “1.” When the MPE bit is cleared to “0,” the multiprocessor communication function is disabled regardless of the setting of the MP bit.

Bit 2

MP	Description	
0	Multiprocessor communication function is disabled.	(Initial value)
1	Multiprocessor communication function is enabled.	

Bits 1 and 0—Clock Select 1 and 0 (CKS1 and CKS0): These bits select the internal clock source when the baud rate generator is clocked from within the chip.

Bit 1 CKS1	Bit 0 CKS0	Description	
0	0	ϕ clock	(Initial value)
0	1	$\phi/4$ clock	
1	0	$\phi/16$ clock	
1	1	$\phi/64$ clock	

10.2.6 Serial Control Register (SCR)—H'FFDA, H'FF8A

Bit:	7	6	5	4	3	2	1	0
	TIE	RIE	TE	RE	MPIE	TEIE	CKE1	CKE0
Initial value:	0	0	0	0	0	0	0	0
Read/Write:	R/W	R/W	R/W	R/W	R/W	R/W	R/W	R/W

The SCR is an 8-bit readable/writable register that enables or disables various SCI functions. It is initialized to H'00 at a reset and in the standby modes.

Bit 7—Transmit Interrupt Enable (TIE): This bit enables or disables the TDR-empty interrupt (TxI) requested when the transmit data register empty (TDRE) bit in the serial status register (SSR) is set to “1.”

Bit 7

TIE	Description
0	The TDR-empty interrupt request (TxI) is disabled. (Initial value)
1	The TDR-empty interrupt request (TxI) is enabled.

Bit 6—Receive Interrupt Enable (RIE): This bit enables or disables the receive-end interrupt (RXI) requested when the receive data register full (RDRF) bit in the serial status register (SSR) is set to “1,” and the receive error interrupt (ERI) requested when the overrun error (ORER), framing error (FER), or parity error (PER) bit in the serial status register (SSR) is set to “1.”

Bit 6

RIE	Description
0	The receive-end interrupt (RXI) and receive-error (ERI) requests are disabled. (Initial value)
1	The receive-end interrupt (RXI) and receive-error (ERI) requests are enabled.

Bit 5—Transmit Enable (TE): This bit enables or disables the transmit function. When the transmit function is enabled, the TxD pin is automatically used for output. When the transmit function is disabled, the TxD pin can be used as a general-purpose I/O port.

Bit 5

TE	Description
0	The transmit function is disabled. (Initial value) The TxD pin can be used for general-purpose I/O.
1	The transmit function is enabled. The TxD pin is used for output.

Bit 4—Receive Enable (RE): This bit enables or disables the receive function. When the receive function is enabled, the RxD pin is automatically used for input. When the receive function is disabled, the RxD pin is available as a general-purpose I/O port.

Bit 4

RE	Description	
0	The receive function is disabled. The RxD pin can be used for general-purpose I/O.	(Initial value)
1	The receive function is enabled. The RxD pin is used for input.	

Bit 3—Multiprocessor Interrupt Enable (MPIE): When serial data are received in a multiprocessor format, this bit enables or disables the receive-end interrupt (RxI) and receive-error interrupt (ERI) until data with the multiprocessor bit set to “1” are received. It also enables or disables the transfer of received data from the RSR to the RDR, and enables or disables setting of the RDRF, FER, PER, and ORER bits in the serial status register (SSR).

The MPIE bit is ignored when the MP bit is cleared to “0,” and in synchronous mode.

Clearing the MPIE bit to “0” disables the multiprocessor receive interrupt function. In this condition data are received regardless of the value of the multiprocessor bit in the receive data.

Setting the MPIE bit to “1” enables the multiprocessor receive interrupt function. In this condition, if the multiprocessor bit in the receive data is “0,” the receive-end interrupt (RxI) and receive-error interrupt (ERI) are disabled, the receive data are not transferred from the RSR to the RDR, and the RDRF, FER, PER, and ORER bits in the serial status register (SSR) are not set. If the multiprocessor bit is “1,” however, the MPB bit in the SSR is set to “1,” the MPIE bit is cleared to “0,” the receive data are transferred from the RSR to the RDR, the FER, PER, and ORER bits can be set, and the receive-end and receive-error interrupts are enabled.

Bit 3

MPIE	Description	
0	The multiprocessor receive interrupt function is disabled. (Normal receive operation)	(Initial value)
1	The multiprocessor receive interrupt function is enabled. During the interval before data with the multiprocessor bit set to “1” are received, the receive interrupt request (RxI) and receive-error interrupt request (ERI) are disabled, the RDRF, FER, PER, and ORER bits are not set in the serial status register (SSR), and no data are transferred from the RSR to the RDR. The MPIE bit is cleared at the following times: <ul style="list-style-type: none"> (1) When “0” is written in MPIE. (2) When data with the multiprocessor bit set to “1” are received. 	

Bit 2—Transmit-End Interrupt Enable (TEIE): This bit enables or disables the TSR-empty interrupt (TEI) requested when the transmit-end bit (TEND) in the serial status register (SSR) is set to “1.”

Bit 2 TEIE	Description	
0	The TSR-empty interrupt request (TEI) is disabled.	(Initial value)
1	The TSR-empty interrupt request (TEI) is enabled.	

Bit 1—Clock Enable 1 (CKE1): This bit selects the internal or external clock source for the baud rate generator. When the external clock source is selected, the SCK pin is automatically used for input of the external clock signal.

Bit 1 CKE1	Description	
0	Internal clock source. When C/A = “1,” the serial clock signal is output at the SCK pin. When C/A = “0,” output depends on the CKE0 bit.	(Initial value)
1	External clock source. The SCK pin is used for input.	

Bit 0—Clock Enable 0 (CKE0): When an internal clock source is used in asynchronous mode, this bit enables or disables serial clock output at the SCK pin.

This bit is ignored when the external clock is selected, or when synchronous mode is selected.

For further information on the communication format and clock source selection, see table 10.7 in section 10.3, “Operation.”

Bit 0 CKE0	Description	
0	The SCK pin is not used by the SCI (and is available as a general-purpose I/O port).	(Initial value)
1	The SCK pin is used for serial clock output.	

10.2.7 Serial Status Register (SSR)—H'FFDC, H'FF8C

Bit:	7	6	5	4	3	2	1	0
	TDRE	RDRF	ORER	FER	PER	TEND	MPB	MPBT
Initial value:	1	0	0	0	0	1	0	0
Read/Write:	R/(W)*	R/(W)*	R/(W)*	R/(W)*	R/(W)*	R	R	R/W

Note: Software can write a "0" to clear the flags, but cannot write a "1" in these bits.

The SSR is an 8-bit register that indicates transmit and receive status. It is initialized to H'84 at a reset and in the standby modes.

Bit 7—Transmit Data Register Empty (TDRE): This bit indicates when the TDR contents have been transferred to the TSR and the next character can safely be written in the TDR.

Bit 7

TDRE	Description
0	To clear TDRE, the CPU must read TDRE after it has been set to "1," then write a "0" in this bit.
1	This bit is set to 1 at the following times: (Initial value) (1) When TDR contents are transferred to the TSR. (2) When the TE bit in the SCR is cleared to "0."

Bit 6—Receive Data Register Full (RDRF): This bit indicates when one character has been received and transferred to the RDR.

Bit 6

RDRF	Description
0	To clear RDRF, the CPU must read RDRF after it has been set to "1," then write a "0" in this bit. (Initial value)
1	This bit is set to 1 when one character is received without error and transferred from the RSR to the RDR.

Bit 5—Overrun Error (ORER): This bit indicates an overrun error during reception.

Bit 5

ORER	Description
0	To clear ORER, the CPU must read ORER after it has been set to "1," then write a "0" in this bit. (Initial value)
1	This bit is set to "1" if reception of the next character ends while the receive data register is still full (RDRF = "1").

Bit 4—Framing Error (FER): This bit indicates a framing error during data reception in asynchronous mode. It has no meaning in synchronous mode.

Bit 4

FER	Description
0	To clear FER, the CPU must read FER after it has been set to “1,” (Initial value) then write a “0” in this bit.
1	This bit is set to “1” if a framing error occurs (stop bit = “0”).

Bit 3—Parity Error (PER): This bit indicates a parity error during data reception in the asynchronous mode, when a communication format with parity bits is used.

This bit has no meaning in the synchronous mode, or when a communication format without parity bits is used.

Bit 3

PER	Description
0	To clear PER, the CPU must read PER after it has been set to “1,” (Initial value) then write a “0” in this bit.
1	This bit is set to “1” when a parity error occurs (the parity of the received data does not match the parity selected by the O/E bit in SMR).

Bit 2—Transmit End (TEND): This bit indicates that the serial communication interface has stopped transmitting because there was no valid data in the TDR when the last bit of the current character was transmitted. The TEND bit is also set to “1” when the TE bit in the serial control register (SCR) is cleared to “0.”

The TEND bit can be read but not written. To clear TEND to “0,” software must read the serial status register while TDRE = “1,” then write “0” in TDRE.

Bit 2

TEND	Description
0	To clear TEND, the CPU must read TDRE after it has been set to “1,” (Initial value) then write a “0” in TDRE.
1	This bit is set to “1” when: (1) TE = “0” (2) TDRE = “1” at the end of transmission of a character

Bit 1—Multiprocessor Bit (MPB): Stores the value of the multiprocessor bit in data received in a multiprocessor format in asynchronous communication mode. This bit is cleared to “0” in synchronous mode, or when a multiprocessor format is not used. If the RE bit is cleared to “0” when a multiprocessor format is used, the MPB bit retains its previous value.

MPB can be read but not written.

Bit 1

MPB	Description	
0	Multiprocessor bit = “0” in receive data.	(Initial value)
1	Multiprocessor bit = “1” in receive data.	

Bit 0—Multiprocessor Bit Transfer (MPBT): Stores the value of the multiprocessor bit inserted in transmit data when a multiprocessor format is used in asynchronous communication mode. The MPBT bit has no effect in synchronous mode, or when a multiprocessor format is not used. It is not used in receiving data.

Bit 0

MPBT	Description	
0	Multiprocessor bit = “0” in transmit data.	(Initial value)
1	Multiprocessor bit = “1” in transmit data.	

10.2.8 Bit Rate Register (BRR)—H'FFD9, H'FF89

Bit:	7	6	5	4	3	2	1	0
Initial value:	1	1	1	1	1	1	1	1
Read/Write:	R/W	R/W	R/W	R/W	R/W	R/W	R/W	R/W

The BRR is an 8-bit register that, together with the CKS1 and CKS0 bits in the SMR, determines the baud rate output by the baud rate generator.

The BRR is initialized to H'FF (the slowest rate) at a reset and in the standby modes.

Tables 10.3 and 10.4 show examples of BRR (N) and CKS (n) settings for commonly used bit rates. Table 10.5 lists the maximum bit rates in asynchronous mode.

Table 10.3 Examples of BRR Settings in Asynchronous Mode (1)

Bit Rate	XTAL Frequency (MHz)											
	2			2.4576			4			4.194304		
	n	N	Error (%)	n	N	Error (%)	n	N	Error (%)	n	N	Error (%)
110	1	70	+0.03	1	86	+0.31	1	141	+0.03	1	148	-0.04
150	0	207	+0.16	0	255	0	1	103	+0.16	1	108	+0.21
300	0	103	+0.16	0	127	0	0	207	+0.16	0	217	+0.21
600	0	51	+0.16	0	63	0	0	103	+0.16	0	108	+0.21
1200	0	25	+0.16	0	31	0	0	51	+0.16	0	54	-0.70
2400	0	12	+0.16	0	15	0	0	25	+0.16	0	26	+1.14
4800	—	—	—	0	7	0	0	12	+0.16	0	13	-2.48
9600	—	—	—	0	3	0	—	—	—	0	6	-2.48
19200	—	—	—	0	1	0	—	—	—	—	—	—
31250	0	0	0	—	—	—	0	1	0	—	—	—
38400	—	—	—	0	0	0	—	—	—	—	—	—

Table 10.3 Examples of BRR Settings in Asynchronous Mode (2)

Bit Rate	XTAL Frequency (MHz)											
	4.9152			6			7.3728			8		
	n	N	Error (%)	n	N	Error (%)	n	N	Error (%)	n	N	Error (%)
110	1	174	-0.26	2	52	+0.50	2	64	+0.70	2	70	+0.03
150	1	127	0	1	155	+0.16	1	191	0	1	207	+0.16
300	0	255	0	1	77	+0.16	1	95	0	1	103	+0.16
600	0	127	0	0	155	+0.16	0	191	0	0	207	+0.16
1200	0	63	0	0	77	+0.16	0	95	0	0	103	+0.16
2400	0	31	0	0	38	+0.16	0	47	0	0	51	+0.16
4800	0	15	0	0	19	-2.34	0	23	0	0	25	+0.16
9600	0	7	0	0	9	-2.34	0	11	0	0	12	+0.16
19200	0	3	0	0	4	-2.34	0	5	0	—	—	—
31250	—	—	—	0	2	0	—	—	—	0	3	0
38400	0	1	0	—	—	—	0	2	0	—	—	—

Table 10.3 Examples of BRR Settings in Asynchronous Mode (3)

Bit Rate	XTAL Frequency (MHz)											
	9.8304			10			12			12.288		
	n	N	Error (%)	n	N	Error (%)	n	N	Error (%)	n	N	Error (%)
110	2	86	+0.31	2	88	-0.25	2	106	-0.44	2	108	+0.08
150	1	255	0	2	64	+0.16	2	77	+0.16	2	79	0
300	1	127	0	1	129	+0.16	1	155	+0.16	1	159	0
600	0	255	0	1	64	+0.16	1	77	+0.16	1	79	0
1200	0	127	0	0	129	+0.16	0	155	+0.16	0	159	0
2400	0	63	0	0	64	+0.16	0	77	+0.16	0	79	0
4800	0	31	0	0	32	-1.36	0	38	+0.16	0	39	0
9600	0	15	0	0	15	+1.73	0	19	-2.34	0	19	0
19200	0	7	0	0	7	+1.73	0	9	-2.34	0	9	0
31250	0	4	-1.70	0	4	0	0	5	0	0	5	+2.40
38400	0	3	0	0	3	+1.73	0	4	-2.34	0	4	0

Table 10.3 Examples of BRR Settings in Asynchronous Mode (4)

Bit Rate	XTAL Frequency (MHz)											
	14.7456			16			19.6608			20		
	n	N	Error (%)	n	N	Error (%)	n	N	Error (%)	n	N	Error (%)
110	2	130	-0.07	2	141	+0.03	2	174	-0.26	2	177	-0.25
150	2	95	0	2	103	+0.16	2	127	0	2	129	+0.16
300	1	191	0	1	207	+0.16	1	255	0	2	64	+0.16
600	1	95	0	1	103	+0.16	1	127	0	1	129	+0.16
1200	0	191	0	0	207	+0.16	0	255	0	1	64	+0.16
2400	0	95	0	0	103	+0.16	0	127	0	0	129	+0.16
4800	0	47	0	0	51	+0.16	0	63	0	0	64	+0.16
9600	0	23	0	0	25	+0.16	0	31	0	0	32	-1.36
19200	0	11	0	0	12	+0.16	0	15	0	0	15	+1.73
31250	—	—	—	0	7	0	0	9	-1.70	0	9	0
38400	0	5	0	—	—	—	0	7	0	0	7	+1.73

Note: If possible, the error should be within 1%.

$$B = \frac{OSC}{64 \times 2^{2n} \times (N + 1)} \times 10^6$$

$$N = \frac{OSC \times 10^6}{64 \times 2^{2n} \times B} - 1$$

N: BRR value ($0 \leq N \leq 255$)

OSC: Crystal oscillator frequency in MHz

B: Baud rate (bits/second)

n: Internal clock source (0, 1, 2, or 3)

The meaning of n is given by the table below:

n	CKS1	CKS0	Clock
0	0	0	ϕ
1	0	1	$\phi/4$
2	1	0	$\phi/16$
3	1	1	$\phi/64$

Table 10.4 Examples of BRR Settings in Synchronous Mode

Bit Rate	XTAL Frequency (MHz)											
	2		4		8		10		16		20	
	n	N	n	N	n	N	n	N	n	N	n	N
100	—	—	—	—	—	—	—	—	—	—	—	—
250	1	249	2	124	2	249	—	—	3	124	—	—
500	1	124	1	249	2	124	—	—	2	249	—	—
1k	0	249	1	124	1	249	—	—	2	124	—	—
2.5k	0	99	0	199	1	99	1	124	1	199	1	249
5k	0	49	0	99	0	199	0	249	1	99	1	124
10k	0	24	0	49	0	99	0	124	0	199	0	249
25k	0	9	0	19	0	39	0	49	0	79	0	99
50k	0	4	0	9	0	19	0	24	0	39	0	49
100k	—	—	0	4	0	9	—	—	0	19	0	24
250k	0	0*	0	1	0	3	0	4	0	7	0	9
500k			0	0*	0	1	—	—	0	3	0	4
1M					0	0*	—	—	0	1	—	—
2.5M											0	0*

Notes: Blank: No setting is available.

—: A setting is available, but the bit rate is inaccurate.

*: Continuous transfer is not possible.

$$B = \text{OSC} \times 10^6 / [8 \times 2^{2n} \times (N + 1)]$$

N: BRR value ($0 \leq N \leq 255$)

OSC: Crystal oscillator frequency in MHz

B: Baud rate (bits per second)

n: Internal clock source (0, 1, 2, or 3)

The meaning of n is given by the table below:

n	CKS1	CKS0	Clock
0	0	0	ϕ
1	0	1	$\phi/4$
2	1	0	$\phi/16$
3	1	1	$\phi/64$

10.2.9 Serial/Timer Control Register (STCR)—H'FFC3

Bit:	7	6	5	4	3	2	1	0
	—	—	—	—	—	MPE	ICKS1	ICKS0
Initial value:	1	1	1	1	1	0	0	0
Read/Write:	—	—	—	—	—	R/W	R/W	R/W

The STCR is an 8-bit readable/writable register that controls the operating mode of the serial communication interface and selects input clock sources for the 8-bit timer counters (TCNT).

The STCR is initialized to HF8 by a reset.

Bits 7 to 3—Reserved: These bits cannot be modified and are always read as “1.”

Bit 2—Multiprocessor Enable (MPE): Enables or disables the multiprocessor communication function on channels SCI0 and SCI1.

Bit 2

MPE	Description
0	The multiprocessor communication function is disabled, (Initial value) regardless of the setting of the MP bit in SMR.
1	The multiprocessor communication function is enabled. The multi-processor format can be selected by setting the MP bit in SMR to “1.”

Bits 1 and 0—Internal Clock Source Select 1 and 0 (ICKS1, ICKS0): These bits select the clock input to the timer counters (TCNT) in the 8-bit timers. For further information see section 7, “8-Bit Timers.”

10.3 Operation

10.3.1 Overview

The SCI supports serial data transfer in two modes. In asynchronous mode each character is synchronized individually. In synchronous mode communication is synchronized with a clock signal.

The selection of asynchronous or synchronous mode and the communication format depend on settings in the SMR as indicated in table 10.5. The clock source depends on the settings of the C/A bit in the SMR and the CKE1 and CKE0 bits in the SCR as indicated in table 10.6.

(1) Asynchronous Mode: Data lengths of seven or eight bits can be selected. A parity bit or multiprocessor bit can be added, and stop bit lengths of one or two bits can be selected. These selections determine the communication format and character length. Framing errors (FER), parity errors (PER) and overrun errors (ORER) can be detected in receive data, and the line-break condition can be detected.

An internal or external clock source can be selected for the serial clock. When an internal clock source is selected, the SCI is clocked by the on-chip baud rate generator and can output a clock signal at the bit-rate frequency. When the external clock source is selected, the on-chip baud rate generator is not used. The external clock frequency must be 16 times the bit rate.

(2) Synchronous Mode: The transmit data length is eight bits. Overrun errors (ORER) can be detected in receive data.

An internal or external clock source can be selected for the serial clock. When an internal clock source is selected, the SCI is clocked by the on-chip baud rate generator and outputs a serial clock signal. When the external clock source is selected, the on-chip baud rate generator is not used and the SCI operates on the input serial clock.

Table 10.5 Communication Formats Used by SCI

SMR settings					Communication Format				
Bit 7 C/A	Bit 6 CHR	Bit 2 MP	Bit 5 PE	Bit 3 STOP	Mode	Data Length	Multipro- cessor Bit	Parity Bit	Stop-Bit Length
0	0	0	0	0	Asynchronous mode	8 bits	None	None	1 bit
				1					2 bits
				0					1 bit
				1					2 bits
				0					1 bit
				1					2 bits
	1	0	0	0	Asynchronous mode (multiprocessor format)	7 bits	None	None	1 bit
				1					2 bits
				0					1 bit
				1					2 bits
				0					1 bit
				1					2 bits
0	1	—	0	Asynchronous mode (multiprocessor format)	8 bits	Present	None	1 bit	
			1					2 bits	
1	—	—	0	Asynchronous mode (multiprocessor format)	7 bits	None	None	1 bit	
			1					2 bits	
1	—	—	—	—	Synchronous mode	8 bits	None	None	

Table 10.6 SCI Clock Source Selection

SMR Bit 7 C/A	SCR		Mode	Serial Transmit/Receive Clock	
	Bit 1 CKE1	Bit 0 CKE0		Clock Source	SCK Pin Function
0	0	0	Async	Internal	Input/output port (not used by SCI)
		1			Serial clock output at bit rate
	1	0		External	Serial clock input at 16 × bit rate
		1			
1	0	0	Sync	Internal	Serial clock output
		1			
	1	0		External	Serial clock input
		1			

10.3.2 Asynchronous Mode

In asynchronous mode, each transmitted or received character is individually synchronized by framing it with a start bit and stop bit.

Full duplex data transfer is possible because the SCI has independent transmit and receive sections. Double buffering in both sections enables the SCI to be programmed for continuous data transfer.

Figure 10.2 shows the general format of one character sent or received in asynchronous mode. The communication channel is normally held in the mark state (High). Character transmission or reception starts with a transition to the space state (Low).

The first bit transmitted or received is the start bit (Low). It is followed by the data bits, in which the least significant bit (LSB) comes first. The data bits are followed by the parity or multiprocessor bit, if present, then the stop bit or bits (High) confirming the end of the frame.

In receiving, the SCI synchronizes on the falling edge of the start bit, and samples each bit at the center of the bit (at the 8th cycle of the internal serial clock, which runs at 16 times the bit rate).

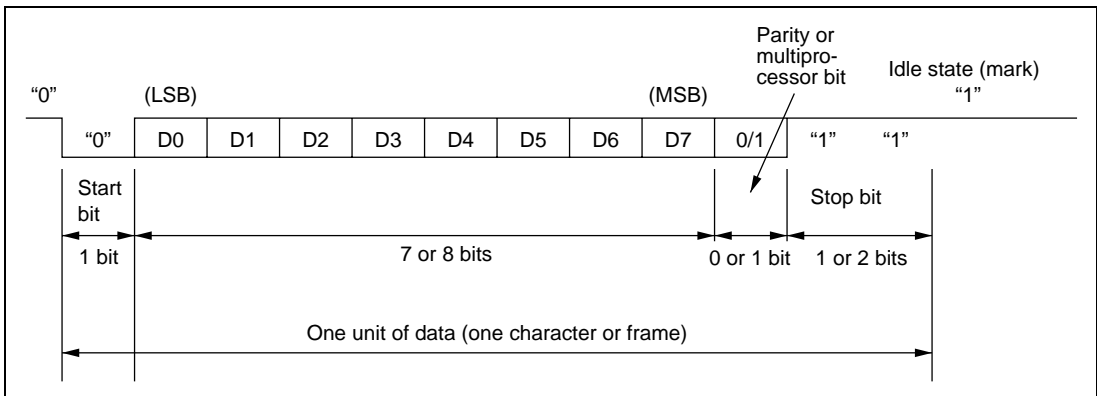

Figure 10.2 Data Format in Asynchronous Mode

(1) Data Format: Table 10.7 lists the data formats that can be sent and received in asynchronous mode. Twelve formats can be selected by bits in the SMR.

Table 10.7 Data Formats in Asynchronous Mode

SMR Bits				1	2	3	4	5	6	7	8	9	10	11	12
0	0	0	0	S	8-Bit data								STOP		
0	0	0	1	S	8-Bit data								STOP	STOP	
0	1	0	0	S	8-Bit data								P	STOP	
0	1	0	1	S	8-Bit data								P	STOP	STOP
1	0	0	0	S	7-Bit data							STOP			
1	0	0	1	S	7-Bit data							STOP	STOP		
1	1	0	0	S	7-Bit data							P	STOP		
1	1	0	1	S	7-Bit data							P	STOP	STOP	
0	—	1	0	S	8-Bit data								MPB	STOP	
0	—	1	1	S	8-Bit data								MPB	STOP	STOP
1	—	1	0	S	7-Bit data							MPB	STOP		
1	—	1	1	S	7-Bit data							MPB	STOP	STOP	

Notes: SMR: Serial mode register
 S: Start bit
 STOP: Stop bit
 P: Parity bit
 MPB: Multiprocessor bit

(2) **Clock:** In asynchronous mode it is possible to select either an internal clock created by the on-chip baud rate generator, or an external clock input at the SCK pin. The selection is made by the C/A bit in the serial mode register (SMR) and the CKE1 and CKE0 bits in the serial control register (SCR). Refer to table 10.7.

If an external clock is input at the SCK pin, its frequency should be 16 times the desired bit rate.

If the internal clock provided by the on-chip baud rate generator is selected and the SCK pin is used for clock output, the output clock frequency is equal to the bit rate, and the clock pulse rises at the center of the transmit data bits. Figure 10.3 shows the phase relationship between the output clock and transmit data.

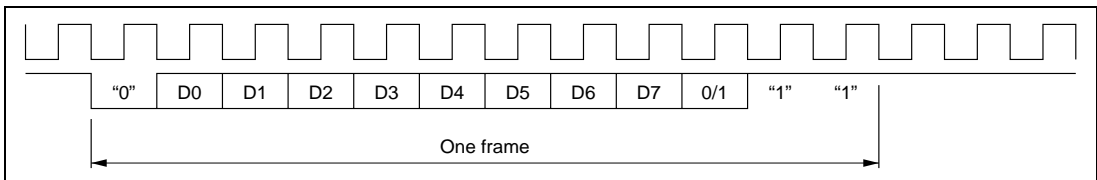

Figure 10.3 Phase Relationship between Clock Output and Transmit Data (Asynchronous Mode)

(3) Transmitting and Receiving Data

- **SCI Initialization:** Before transmitting or receiving, software must clear the TE and RE bits to “0” in the serial control register (SCR), then initialize the SCI as follows.

Note: When changing the communication mode or format, always clear the TE and RE bits to “0” before following the procedure given below. Clearing TE to “0” sets TDRE to “1” and initializes the transmit shift register (TSR). Clearing RE to “0,” however, does not initialize the RDRF, PER, FER, and ORER flags and receive data register (RDR), which retain their previous contents.

When an external clock is used, the clock should not be stopped during initialization or subsequent operation. SCI operation becomes unreliable if the clock is stopped.

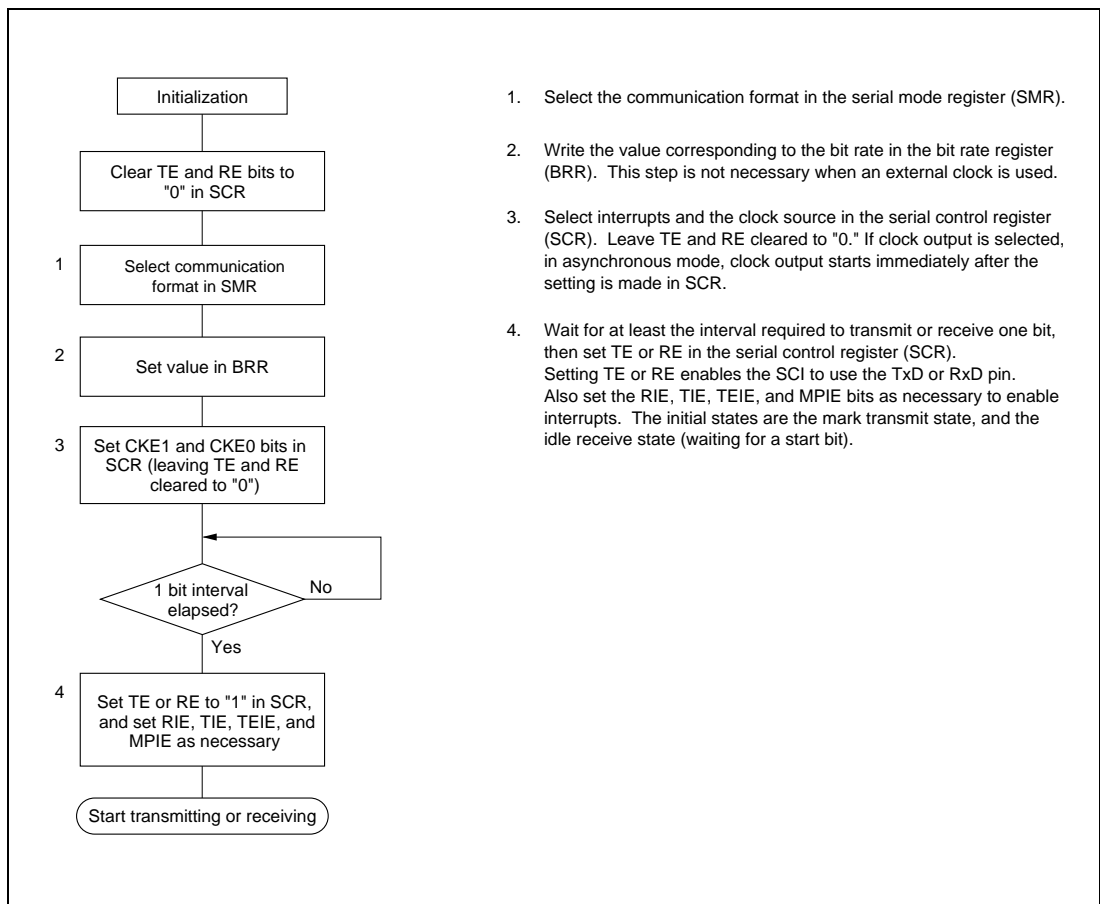
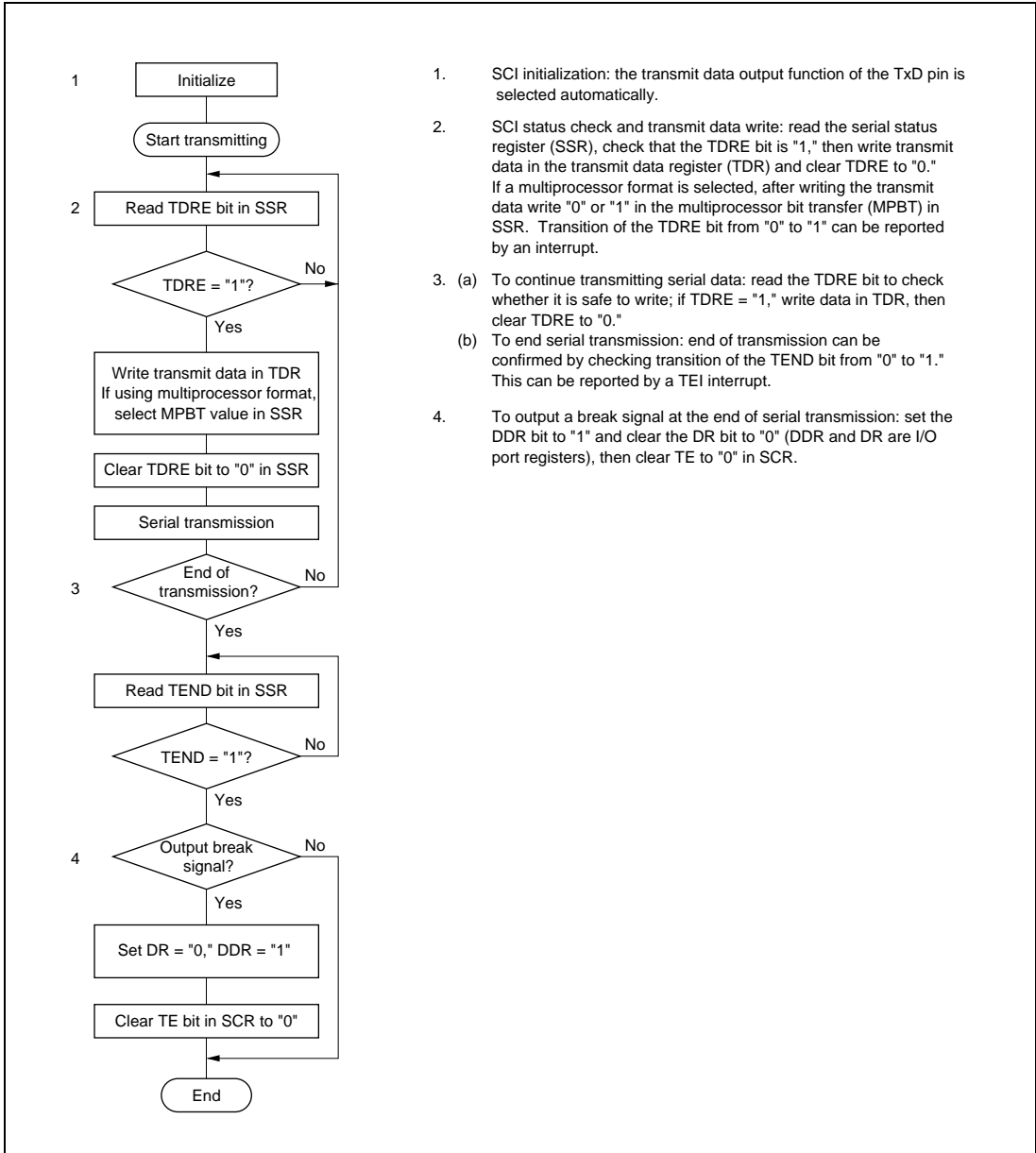

Figure 10.4 Sample Flowchart for SCI Initialization

- **Transmitting Serial Data:** Follow the procedure below for transmitting serial data.



1. SCI initialization: the transmit data output function of the TxD pin is selected automatically.
2. SCI status check and transmit data write: read the serial status register (SSR), check that the TDRE bit is "1," then write transmit data in the transmit data register (TDR) and clear TDRE to "0." If a multiprocessor format is selected, after writing the transmit data write "0" or "1" in the multiprocessor bit transfer (MPBT) in SSR. Transition of the TDRE bit from "0" to "1" can be reported by an interrupt.
 3. (a) To continue transmitting serial data: read the TDRE bit to check whether it is safe to write; if TDRE = "1," write data in TDR, then clear TDRE to "0."
 3. (b) To end serial transmission: end of transmission can be confirmed by checking transition of the TEND bit from "0" to "1." This can be reported by a TEI interrupt.
4. To output a break signal at the end of serial transmission: set the DDR bit to "1" and clear the DR bit to "0" (DDR and DR are I/O port registers), then clear TE to "0" in SCR.

Figure 10.5 Sample Flowchart for Transmitting Serial Data

In transmitting serial data, the SCI operates as follows.

1. The SCI monitors the TDRE bit in SSR. When TDRE is cleared to “0” the SCI recognizes that the transmit data register (TDR) contains new data, and loads this data from TDR into the transmit shift register (TSR).
2. After loading the data from TDR into TSR, the SCI sets the TDRE bit to “1” and starts transmitting. If the TIE bit (TDR-empty interrupt enable) is set to “1” in SCR, the SCI requests a TXI interrupt (TDR-empty interrupt) at this time.

Serial transmit data are transmitted in the following order from the TxD pin:

- (a) Start bit: one “0” bit is output.
 - (b) Transmit data: seven or eight bits are output, LSB first.
 - (c) Parity bit or multiprocessor bit: one parity bit (even or odd parity) or one multiprocessor bit is output. Formats in which neither a parity bit nor a multiprocessor bit is output can also be selected.
 - (d) Stop bit: one or two “1” bits (stop bits) are output.
 - (e) Mark state: output of “1” bits continues until the start bit of the next transmit data.
3. The SCI checks the TDRE bit when it outputs the stop bit. If TDRE is “0,” the SCI loads new data from TDR into TSR, outputs the stop bit, then begins serial transmission of the next frame. If TDRE is “1,” the SCI sets the TEND bit to “1” in SSR, outputs the stop bit, then continues output of “1” bits in the mark state. If the TEIE bit (TSR-empty interrupt enable) in SCR is set to “1,” a TEI interrupt (TSR-empty interrupt) is requested.

Figure 10.6 shows an example of SCI transmit operation in asynchronous mode.

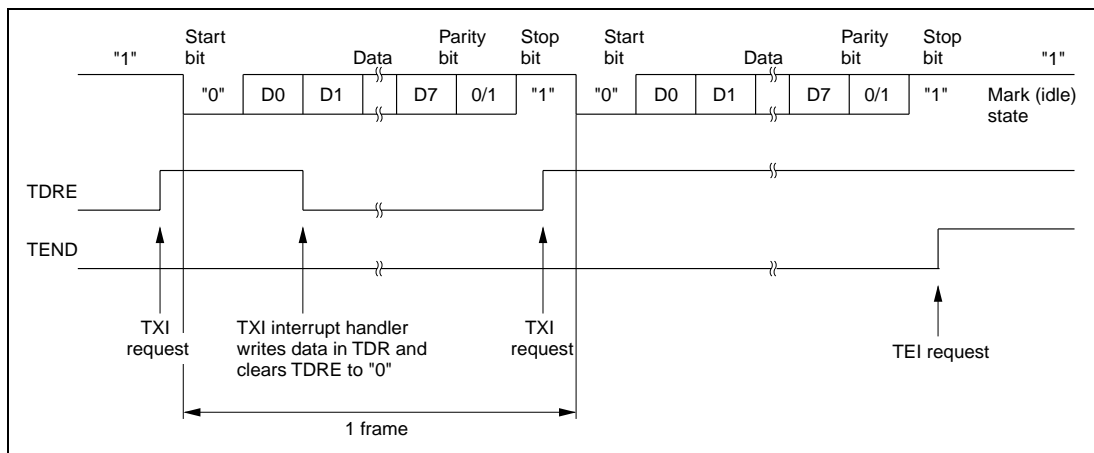

**Figure 10.6 Example of SCI Transmit Operation
(8-bit data with parity and one stop bit)**

- **Receiving Serial Data:** Follow the procedure below for receiving serial data.

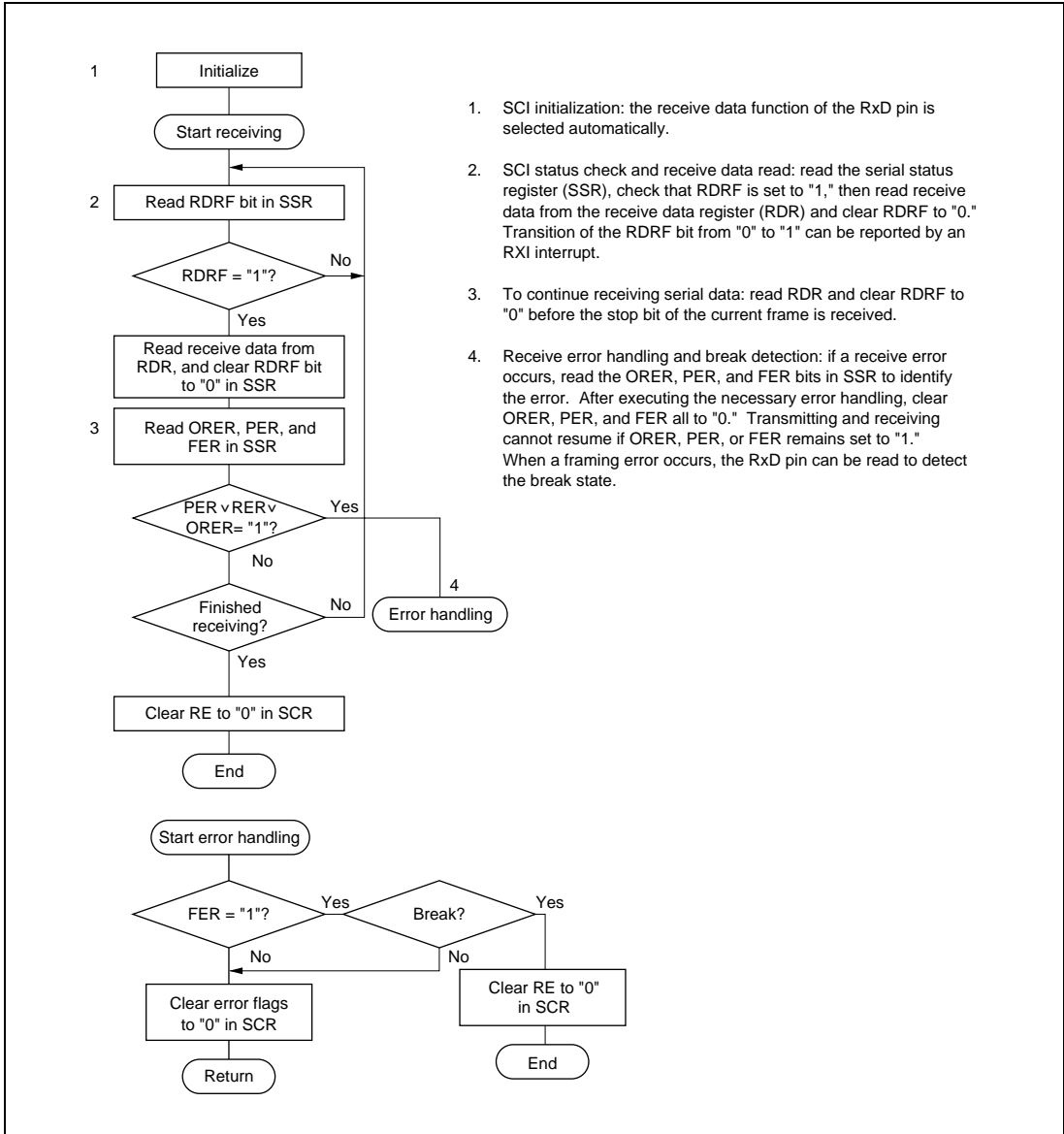

1. SCI initialization: the receive data function of the RxD pin is selected automatically.
2. SCI status check and receive data read: read the serial status register (SSR), check that RDRF is set to "1," then read receive data from the receive data register (RDR) and clear RDRF to "0." Transition of the RDRF bit from "0" to "1" can be reported by an RXI interrupt.
3. To continue receiving serial data: read RDR and clear RDRF to "0" before the stop bit of the current frame is received.
4. Receive error handling and break detection: if a receive error occurs, read the ORER, PER, and FER bits in SSR to identify the error. After executing the necessary error handling, clear ORER, PER, and FER all to "0." Transmitting and receiving cannot resume if ORER, PER, or FER remains set to "1." When a framing error occurs, the RxD pin can be read to detect the break state.

Figure 10.7 Sample Flowchart for Receiving Serial Data

In receiving, the SCI operates as follows.

1. The SCI monitors the receive data line and synchronizes internally when it detects a start bit.
2. Receive data are shifted into RSR in order from LSB to MSB.
3. The parity bit and stop bit are received.

After receiving these bits, the SCI makes the following checks:

- (a) Parity check: the number of 1s in the receive data must match the even or odd parity setting of the O/E bit in SMR.
- (b) Stop bit check: the stop bit value must be “1.” If there are two stop bits, only the first stop bit is checked.
- (c) Status check: RDRF must be “0” so that receive data can be loaded from RSR into RDR.

If these checks all pass, the SCI sets RDRF to “1” and stores the received data in RDR. If one of the checks fails (receive error), the SCI operates as indicated in table 10.8.

Note: When a receive error flag is set, further receiving is disabled. The RDRF bit is not set to “1.” Be sure to clear the error flags.

4. After setting RDRF to “1,” if the RIE bit (receive-end interrupt enable) is set to “1” in SCR, the SCI requests an RXI (receive-end) interrupt. If one of the error flags (ORER, PER, or FER) is set to “1” and the RIE bit in SCR is also set to “1,” the SCI requests an ERI (receive-error) interrupt.

Figure 10.8 shows an example of SCI receive operation in asynchronous mode.

Table 10.8 Receive Error Conditions and SCI Operation

Receive Error	Abbreviation	Condition	Data Transfer
Overrun error	ORER	Receiving of next data ends while RDRF is still set to “1” in SSR	Receive data not loaded from RSR into RDR
Framing error	FER	Stop bit is “0”	Receive data loaded from RSR into RDR
Parity error	PER	Parity of receive data differs from even/odd parity setting in SMR	Receive data loaded from RSR into RDR

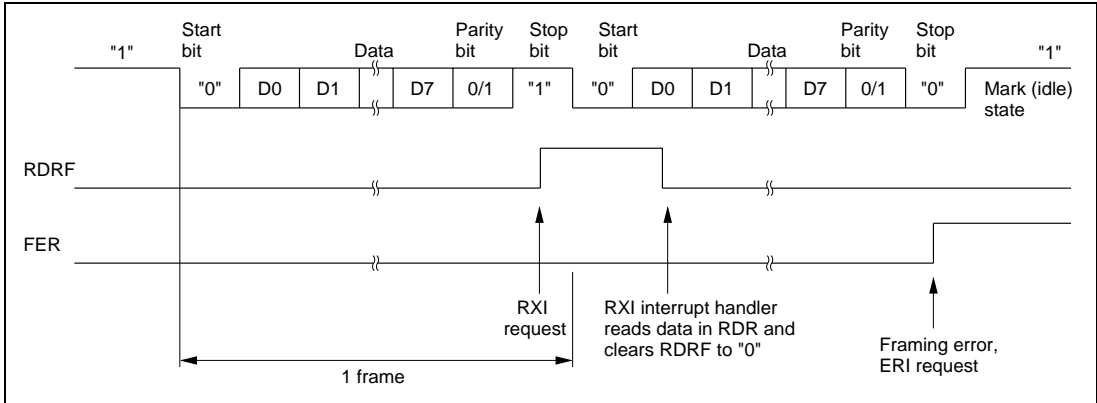

Figure 10.8 Example of SCI Receive Operation (8-bit data with parity and one stop bit)

(4) Multiprocessor Communication

The multiprocessor communication function enables several processors to share a single serial communication line. The processors communicate in asynchronous mode using a format with an additional multiprocessor bit (multiprocessor format).

In multiprocessor communication, each receiving processor is addressed by an ID.

A serial communication cycle consists of two cycles: an ID-sending cycle that identifies the receiving processor, and a data-sending cycle. The multiprocessor bit distinguishes ID-sending cycles from data-sending cycles.

The transmitting processor starts by sending the ID of the receiving processor with which it wants to communicate as data with the multiprocessor bit set to "1." Next the transmitting processor sends transmit data with the multiprocessor bit cleared to "0."

Receiving processors skip incoming data until they receive data with the multiprocessor bit set to "1."

After receiving data with the multiprocessor bit set to "1," the receiving processor with an ID matching the received data continues to receive further incoming data. Multiple processors can send and receive data in this way.

Four formats are available. Parity-bit settings are ignored when a multiprocessor format is selected. For details see table 10.7.

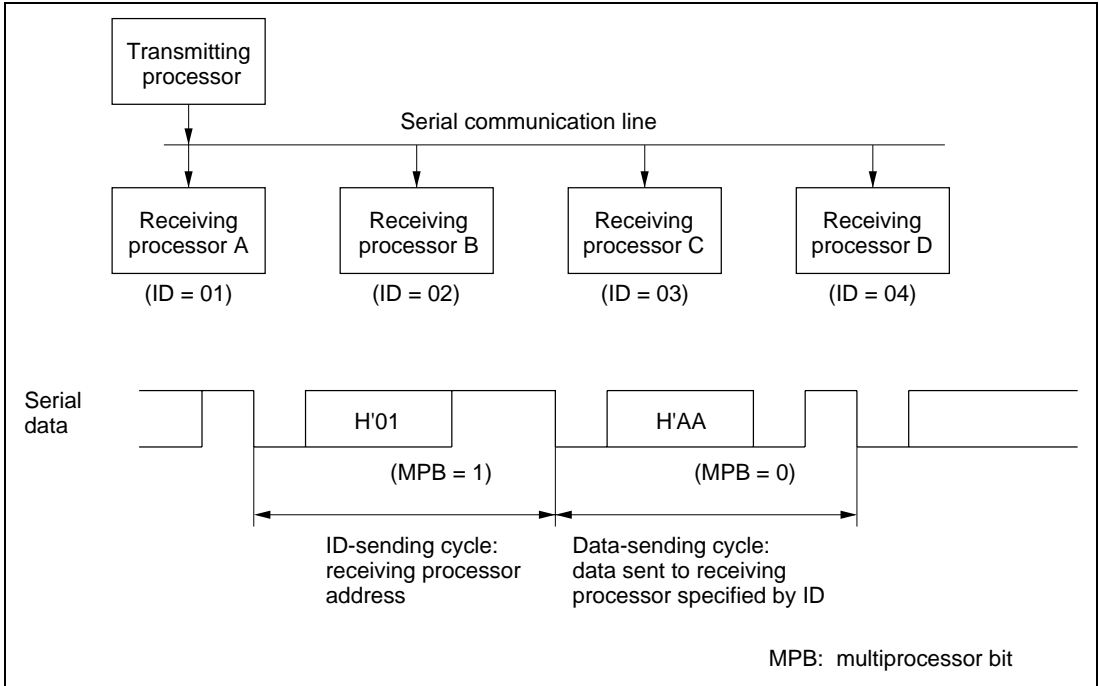

Figure 10.9 Example of Communication among Processors using Multiprocessor Format (sending data H'AA to receiving processor A)

- **Transmitting Multiprocessor Serial Data:** See figures 10.5 and 10.6.
- **Receiving Multiprocessor Serial Data:** Follow the procedure below for receiving multiprocessor serial data.

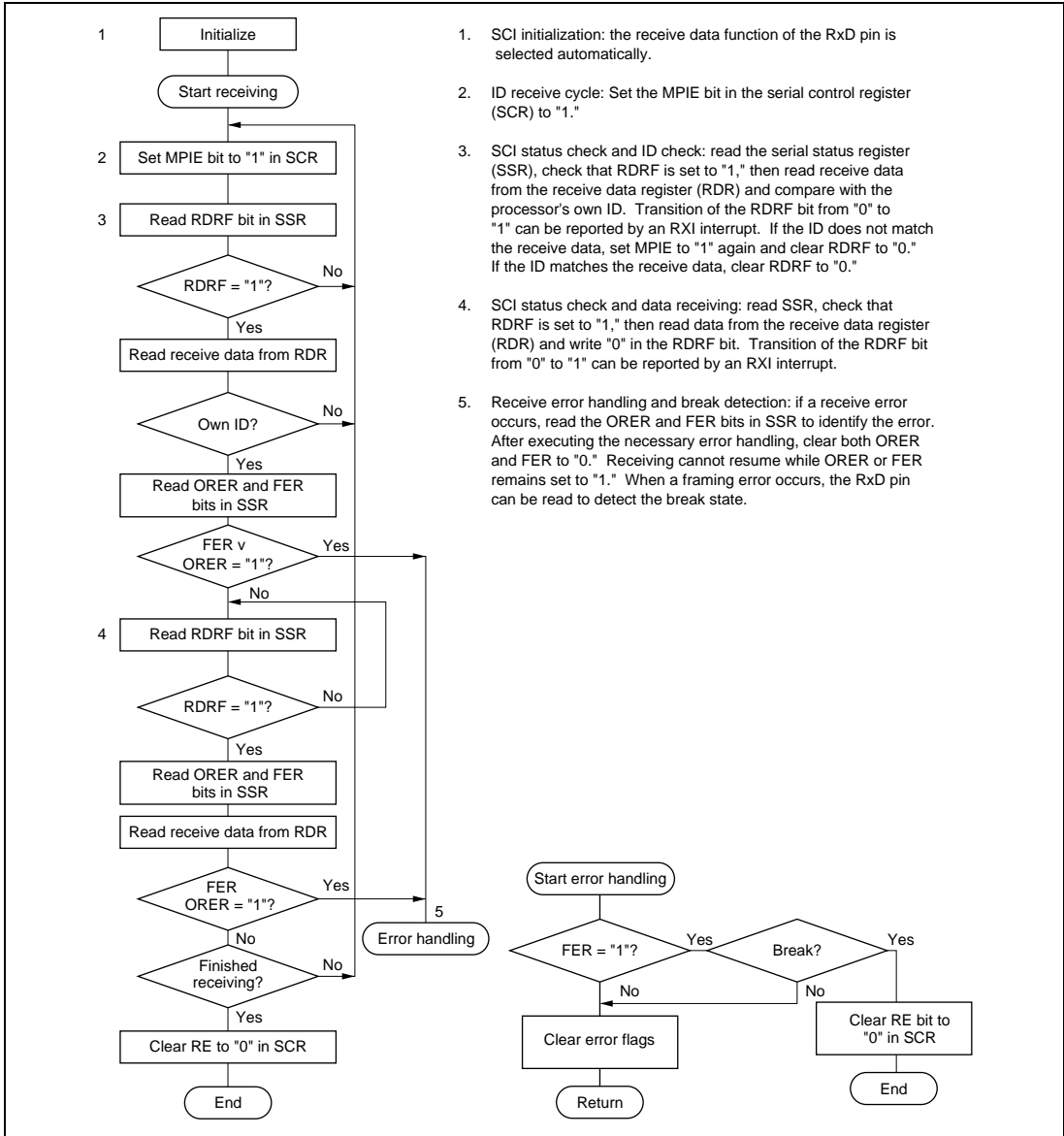

Figure 10.10 Sample Flowchart for Receiving Multiprocessor Serial Data

Figure 10.11 shows an example of SCI receive operation using a multiprocessor format.

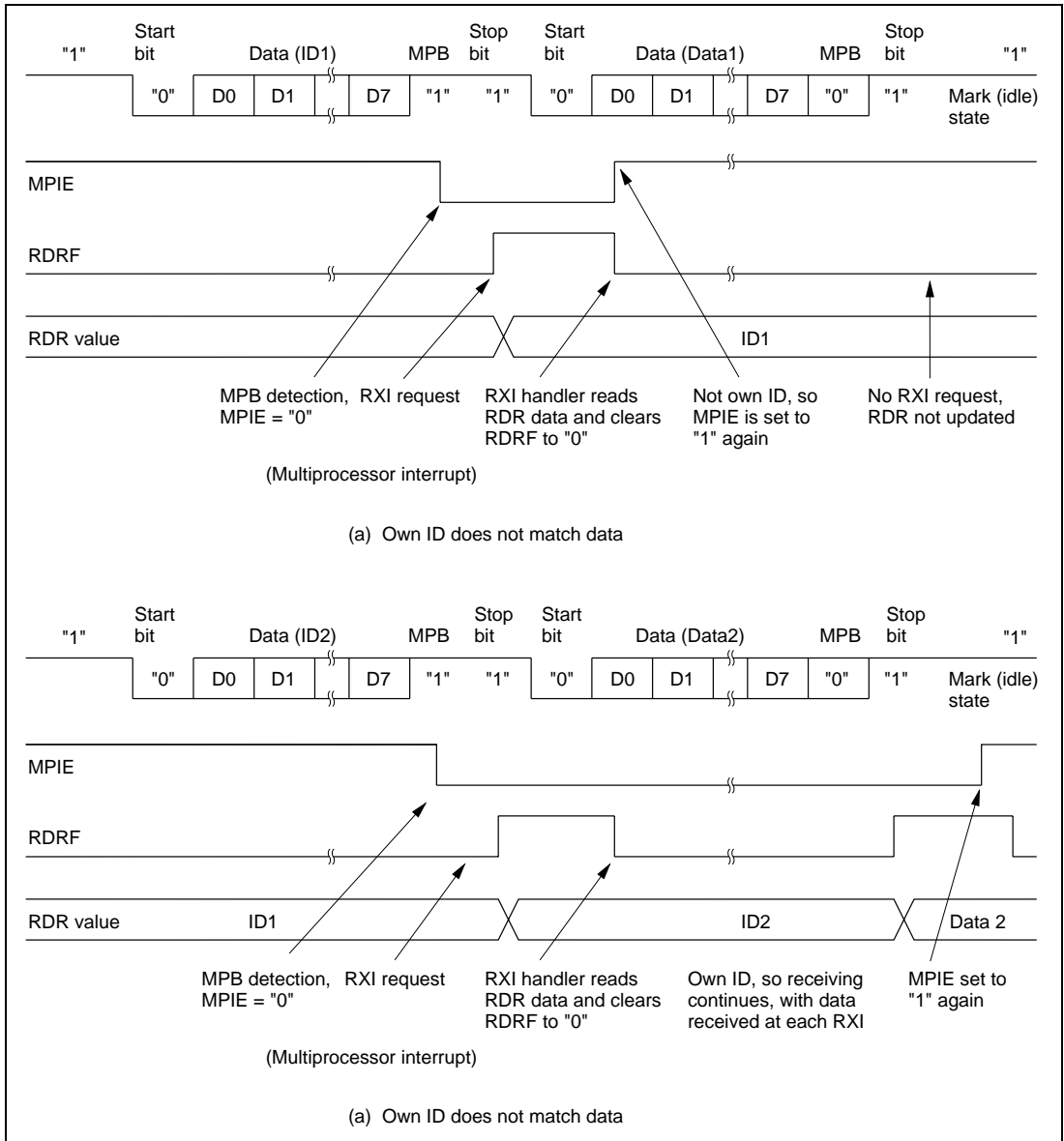

Figure 10.11 Example of SCI Receive Operation (eight-bit data with multiprocessor bit and one stop bit)

10.3.3 Synchronous Mode

(1) Overview: In clocked synchronous mode, the SCI transmits and receives data in synchronization with clock pulses. This mode is suitable for high-speed serial communication.

The SCI transmitter and receiver share the same clock but are otherwise independent, so full duplex communication is possible. The transmitter and receiver are also double buffered, so continuous transmitting or receiving is possible by reading or writing data while transmitting or receiving is in progress.

Figure 10.12 shows the general format in clocked synchronous serial communication.

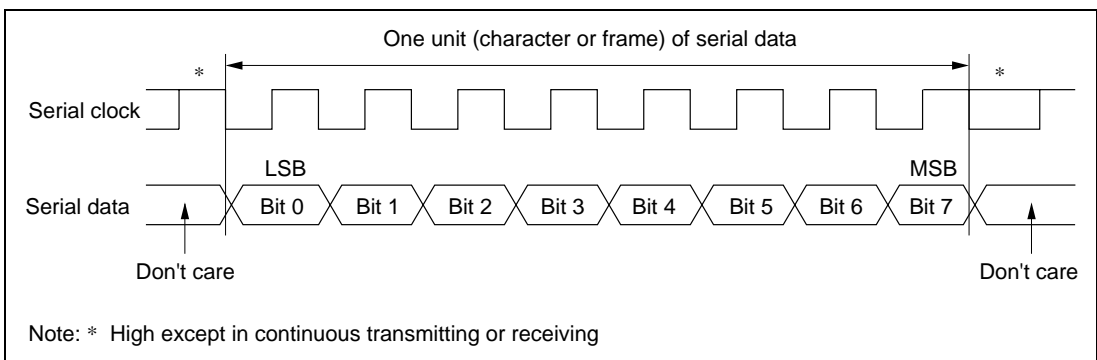

Figure 10.12 Data Format in Clocked Synchronous Communication

In clocked synchronous serial communication, each data bit is sent on the communication line from one falling edge of the serial clock to the next. Data are received in synchronization with the rising edge of the serial clock.

In each character, the serial data bits are transmitted in order from LSB (first) to MSB (last). After output of the MSB, the communication line remains in the state of the MSB.

- **Communication Format:** The data length is fixed at eight bits. No parity bit or multiprocessor bit can be added.
- **Clock:** An internal clock generated by the on-chip baud rate generator or an external clock input from the SCK pin can be selected by clearing or setting the CKE1 bit in the serial control register (SCR). See table 10.6.

When the SCI operates on an internal clock, it outputs the clock signal at the SCK pin. Eight clock pulses are output per transmitted or received character. When the SCI is not transmitting or receiving, the clock signal remains at the high level.

(2) Transmitting and Receiving Data

- **SCI Initialization:** The SCI must be initialized in the same way as in asynchronous mode. See figure 10.4. When switching from asynchronous mode to clocked synchronous mode, check that the ORER, FER, and PER bits are cleared to “0.” Transmitting and receiving cannot begin if ORER, FER, or PER is set to “1.”
- **Transmitting Serial Data:** Follow the procedure below for transmitting serial data.

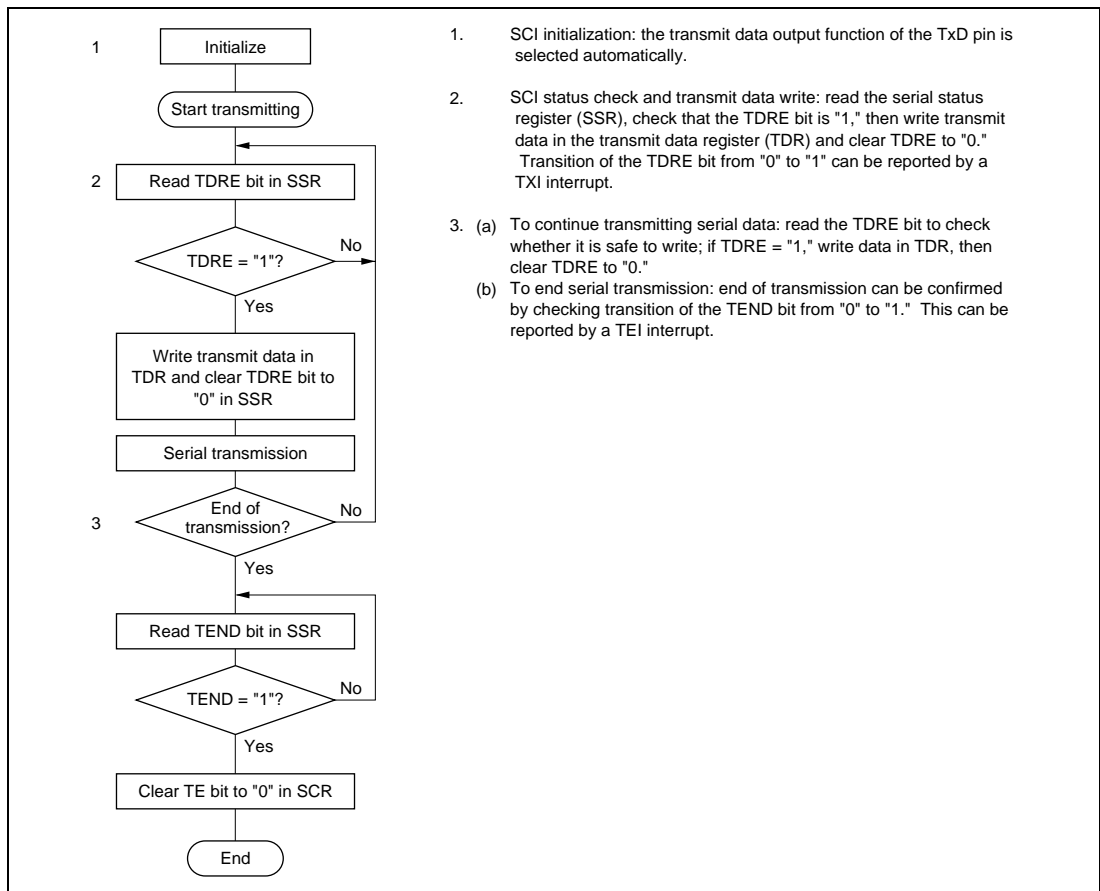

Figure 10.13 Sample Flowchart for Serial Transmitting

In transmitting serial data, the SCI operates as follows.

1. The SCI monitors the TDRE bit in SSR. When TDRE is cleared to “0” the SCI recognizes that the transmit data register (TDR) contains new data, and loads this data from TDR into the transmit shift register (TSR).

2. After loading the data from TDR into TSR, the SCI sets the TDRE bit to “1” and starts transmitting. If the TIE bit (TDR-empty interrupt enable) in SCR is set to “1,” the SCI requests a TXI interrupt (TDR-empty interrupt) at this time.

If clock output is selected the SCI outputs eight serial clock pulses, triggered by the clearing of the TDRE bit to “0.” If an external clock source is selected, the SCI outputs data in synchronization with the input clock.

Data are output from the TxD pin in order from LSB (bit 0) to MSB (bit 7).

3. The SCI checks the TDRE bit when it outputs the MSB (bit 7). If TDRE is “0,” the SCI loads data from TDR into TSR, then begins serial transmission of the next frame. If TDRE is “1,” the SCI sets the TEND bit in SSR to “1,” transmits the MSB, then holds the output in the MSB state. If the TEIE bit (transmit-end interrupt enable) in SCR is set to “1,” a TEI interrupt (TSR-empty interrupt) is requested at this time.
4. After the end of serial transmission, the SCK pin is held at the high level.

Figure 10.14 shows an example of SCI transmit operation.

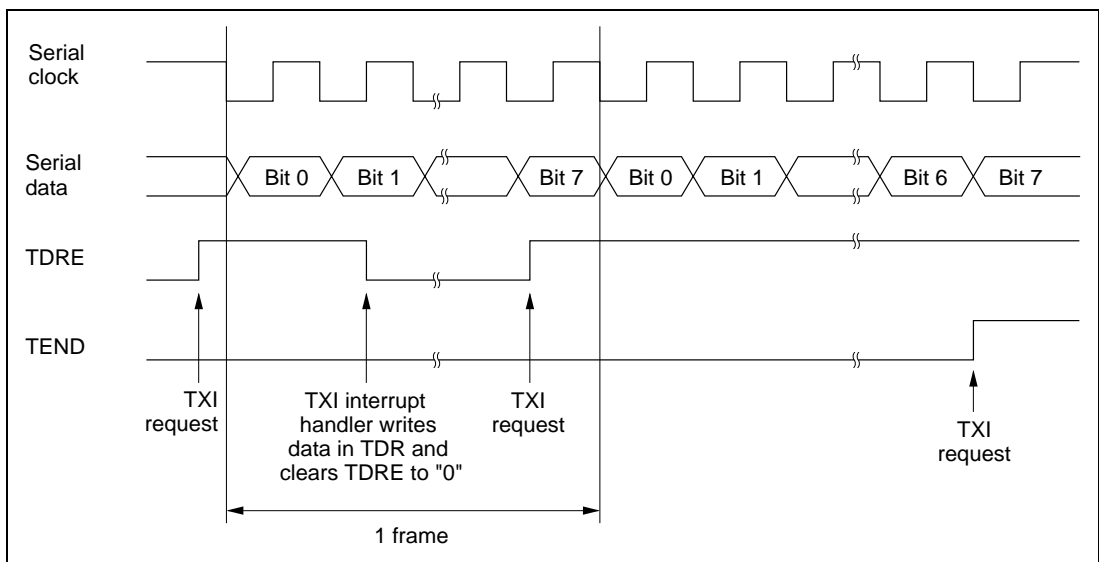

Figure 10.14 Example of SCI Transmit Operation

- **Receiving Serial Data:** Follow the procedure below for receiving serial data. When switching from asynchronous mode to clocked synchronous mode, be sure to check that PER and FER are cleared to “0.” If PER or FER is set to “1” the RDRF bit will not be set and both transmitting and receiving will be disabled.

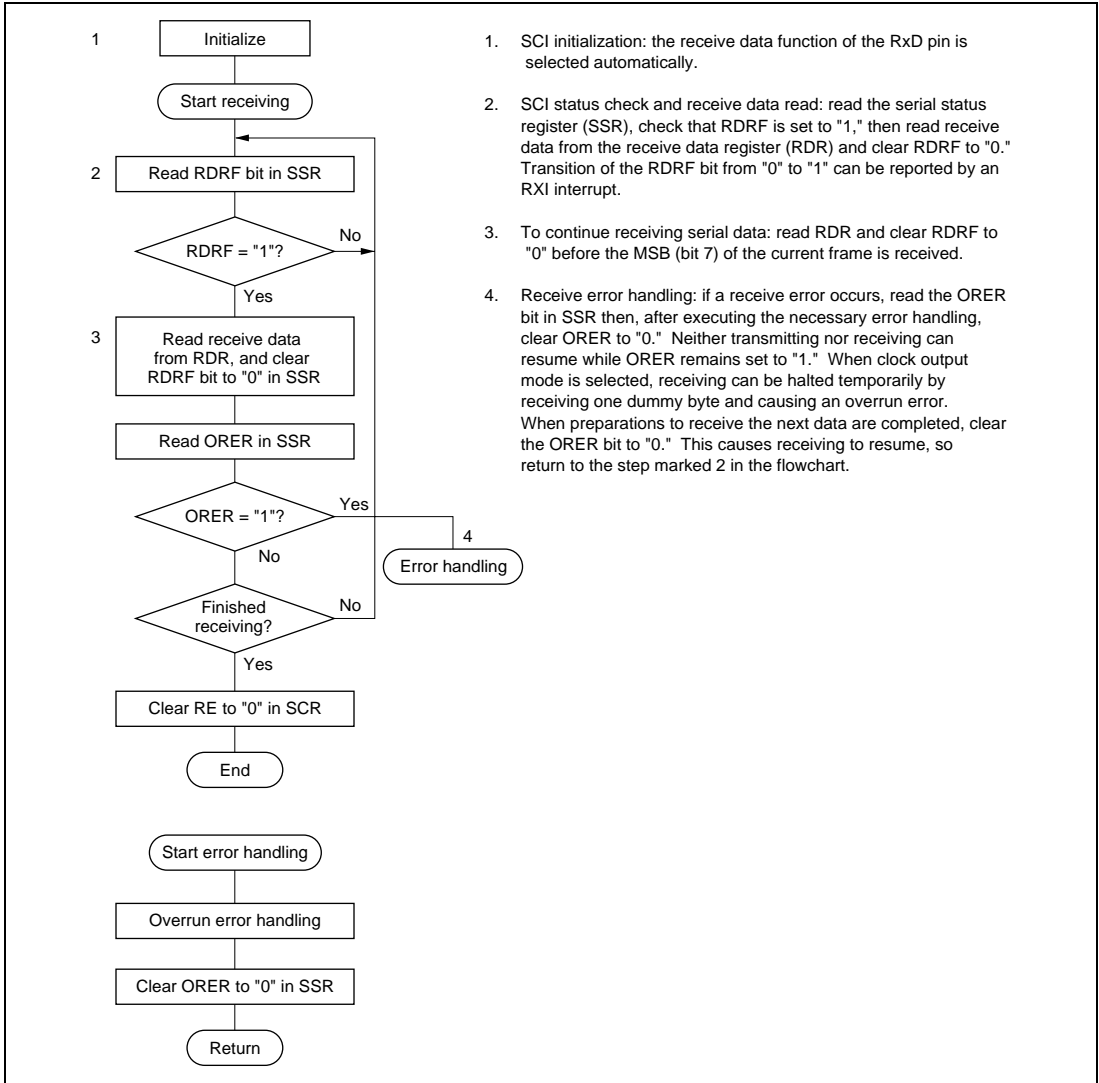

Figure 10.15 Sample Flowchart for Serial Receiving

In receiving, the SCI operates as follows.

1. If an external clock is selected, data are input in synchronization with the input clock. If clock output is selected, as soon as the RE bit is set to "1" the SCI begins outputting the serial clock and inputting data. If clock output is stopped because the ORER bit is set to "1," output of the serial clock and input of data resume as soon as the ORER bit is cleared to "0."
2. Receive data are shifted into RSR in order from LSB to MSB.

After receiving the data, the SCI checks that RDRF is “0” so that receive data can be loaded from RSR into RDR. If this check passes, the SCI sets RDRF to “1” and stores the received data in RDR. If the check does not pass (receive error), the SCI operates as indicated in table 10.8.

Note: Both transmitting and receiving are disabled while a receive error flag is set. The RDRF bit is not set to “1.” Be sure to clear the error flag.

- After setting RDRF to “1,” if the RIE bit (receive-end interrupt enable) is set to “1” in SCR, the SCI requests an RXI (receive-end) interrupt. If the ORER bit is set to “1” and the RIE bit in SCR is set to “1,” the SCI requests an ERI (receive-error) interrupt.

When clock output mode is selected, clock output stops when the RE bit is cleared to “0” or the ORER bit is set to “1.” To prevent clock count errors, it is safest to receive one dummy byte and generate an overrun error.

Figure 10.16 shows an example of SCI receive operation.

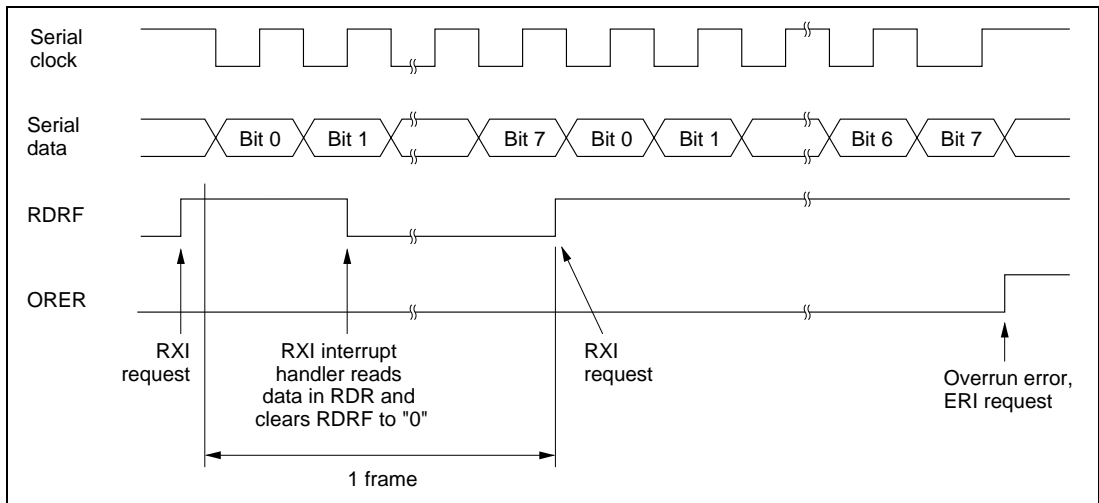
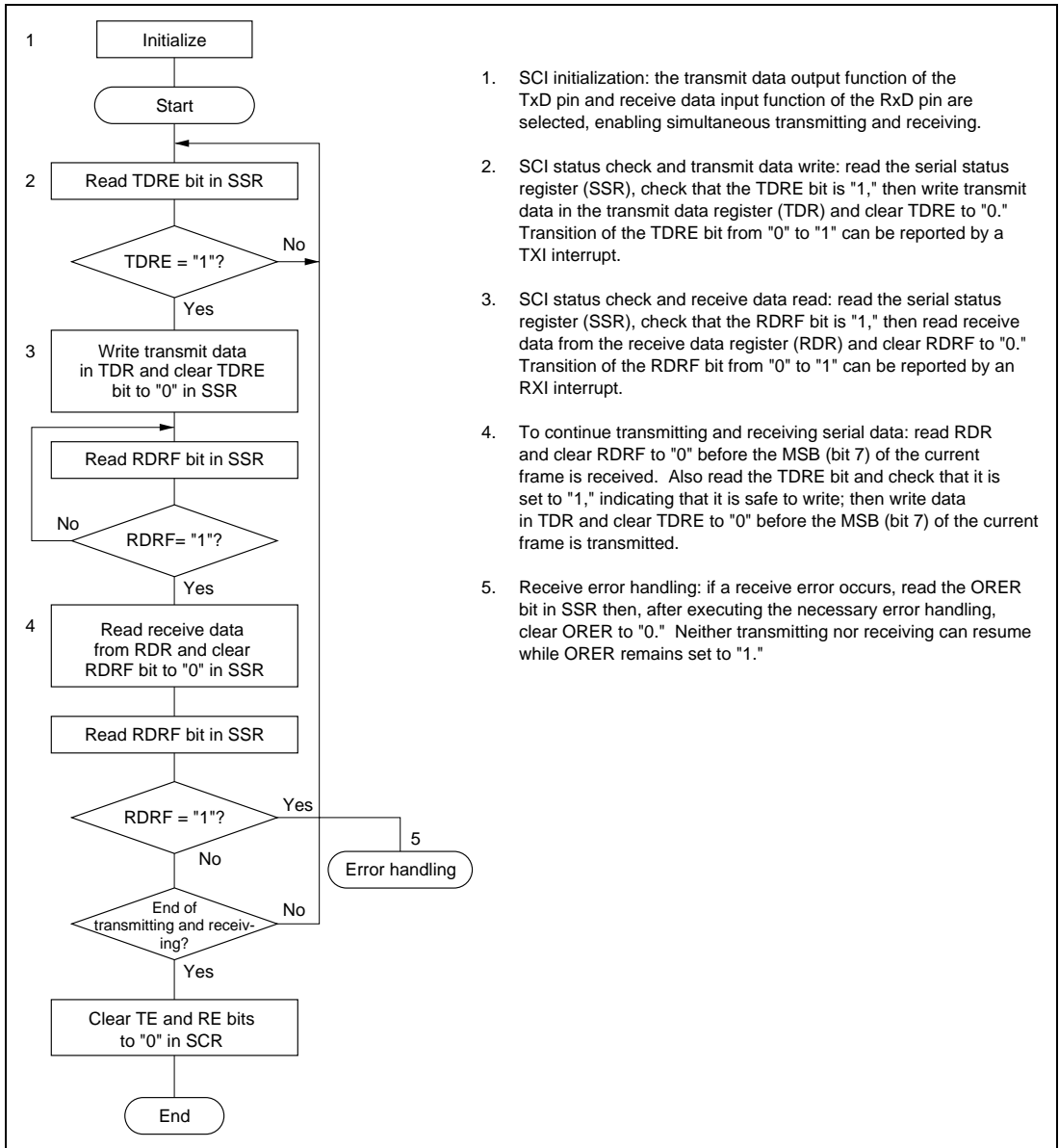

Figure 10.16 Example of SCI Receive Operation

- Transmitting and Receiving Serial Data Simultaneously:** Follow the procedure below for transmitting and receiving serial data simultaneously. If clock output mode is selected, output of the serial clock begins simultaneously with serial transmission.



1. SCI initialization: the transmit data output function of the TxD pin and receive data input function of the RxD pin are selected, enabling simultaneous transmitting and receiving.
2. SCI status check and transmit data write: read the serial status register (SSR), check that the TDRE bit is "1," then write transmit data in the transmit data register (TDR) and clear TDRE to "0." Transition of the TDRE bit from "0" to "1" can be reported by a TXI interrupt.
3. SCI status check and receive data read: read the serial status register (SSR), check that the RDRF bit is "1," then read receive data from the receive data register (RDR) and clear RDRF to "0." Transition of the RDRF bit from "0" to "1" can be reported by an RXI interrupt.
4. To continue transmitting and receiving serial data: read RDR and clear RDRF to "0" before the MSB (bit 7) of the current frame is received. Also read the TDRE bit and check that it is set to "1," indicating that it is safe to write; then write data in TDR and clear TDRE to "0" before the MSB (bit 7) of the current frame is transmitted.
5. Receive error handling: if a receive error occurs, read the ORER bit in SSR then, after executing the necessary error handling, clear ORER to "0." Neither transmitting nor receiving can resume while ORER remains set to "1."

Figure 10.17 Sample Flowchart for Serial Transmitting and Receiving

Note: In switching from transmitting or receiving to simultaneous transmitting and receiving, clear both TE and RE to "0," then set both TE and RE to "1."

10.4 Interrupts

The SCI can request four types of interrupts: ERI, RxI, TxI, and TEI. Table 10.9 indicates the source and priority of these interrupts. The interrupt sources can be enabled or disabled by the TIE, RIE, and TEIE bits in the SCR. Independent signals are sent to the interrupt controller for each interrupt source, except that the receive-error interrupt (ERI) is the logical OR of three sources: overrun error, framing error, and parity error.

The TxI interrupt indicates that the next transmit data can be written. The TEI interrupt indicates that the SCI has stopped transmitting data.

Table 10.9 SCI Interrupt Sources

Interrupt	Description	Priority
ERI	Receive-error interrupt (ORER, FER, or PER)	High
RxI	Receive-end interrupt (RDRF)	↑ Low
TxI	TDR-empty interrupt (TDRE)	
TEI	TSR-empty interrupt (TEND)	

10.5 Application Notes

Application programmers should note the following features of the SCI.

(1) TDR Write: The TDRE bit in the SSR is simply a flag that indicates that the TDR contents have been transferred to the TSR. The TDR contents can be rewritten regardless of the TDRE value. If a new byte is written in the TDR while the TDRE bit is “0,” before the old TDR contents have been moved into the TSR, the old byte will be lost. Software should check that the TDRE bit is set to “1” before writing to the TDR.

(2) Multiple Receive Errors: Table 10.10 lists the values of flag bits in the SSR when multiple receive errors occur, and indicates whether the RSR contents are transferred to the RDR.

Table 10.10 SSR Bit States and Data Transfer when Multiple Receive Errors Occur

Receive Error	SSR Bits				RSR → RDR* ²
	RDRF	ORER	FER	PER	
Overrun error	1* ¹	1	0	0	No
Framing error	0	0	1	0	Yes
Parity error	0	0	0	1	Yes
Overrun and framing errors	1* ¹	1	1	0	No
Overrun and parity errors	1* ¹	1	0	1	No
Framing and parity errors	0	0	1	1	Yes
Overrun, framing, and parity errors	1* ¹	1	1	1	No

Notes: 1. Set to “1” before the overrun error occurs.

2. Yes: The RSR contents are transferred to the RDR.

No: The RSR contents are not transferred to the RDR.

(3) Line Break Detection: When the RxD pin receives a continuous stream of 0’s in asynchronous mode (line-break state), a framing error occurs because the SCI detects a “0” stop bit. The value H’00 is transferred from the RSR to the RDR. Software can detect the line-break state as a framing error accompanied by H’00 data in the RDR.

The SCI continues to receive data, so if the FER bit is cleared to “0” another framing error will occur.

(4) Sampling Timing and Receive Margin in Asynchronous Mode: The serial clock used by the SCI in asynchronous mode runs at 16 times the baud rate. The falling edge of the start bit is detected by sampling the RxD input on the falling edge of this clock. After the start bit is detected, each bit of receive data in the frame (including the start bit, parity bit, and stop bit or bits) is sampled on the rising edge of the serial clock pulse at the center of the bit. See figure 10.18.

It follows that the receive margin can be calculated as in equation (1).

When the absolute frequency deviation of the clock signal is 0 and the clock duty factor is 0.5, data can theoretically be received with distortion up to the margin given by equation (2). This is a theoretical limit, however. In practice, system designers should allow a margin of 20% to 30%.

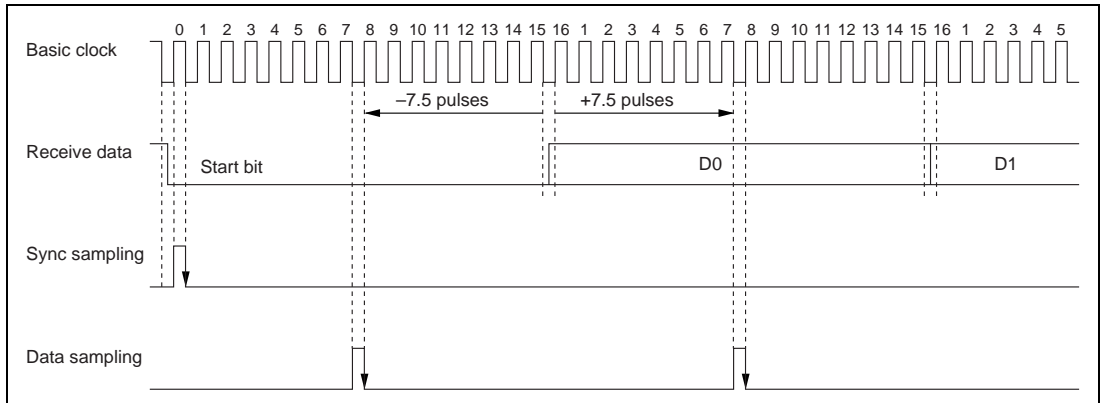

Figure 10.18 Sampling Timing (Asynchronous mode)

$$M = \{(0.5 - 1/2N) - (D - 0.5)/N - (L - 0.5)F\} \times 100 [\%] \quad (1)$$

M: Receive margin

N: Ratio of basic clock to baud rate (N=16)

D: Duty factor of clock-ratio of High pulse width to Low width (0.5 to 1.0)

L: Frame length (9 to 12)

F: Absolute clock frequency deviation

When D = 0.5 and F = 0

$$M = (0.5 - 1/2 \times 16) \times 100 [\%] = 46.875\% \quad (2)$$

Section 11 A/D Converter

11.1 Overview

The H8/338 Series includes an analog-to-digital converter module with eight input channels. A/D conversion is performed by the successive approximations method with 8-bit resolution.

11.1.1 Features

The features of the on-chip A/D module are:

- 8-bit resolution
- Eight analog input channels
- Rapid conversion
Conversion time is 12.2 μ s per channel (minimum) with a 10MHz system clock
- Single and scan modes
 - Single mode: A/D conversion is performed once.
 - Scan mode: A/D conversion is performed in a repeated cycle on one to four channels.
- Four 8-bit data registers
These registers store A/D conversion results for up to four channels.
- Sample-and-hold function
- External triggering can be selected
- A CPU interrupt (ADI) can be requested at the completion of each A/D conversion cycle.

11.1.2 Block Diagram

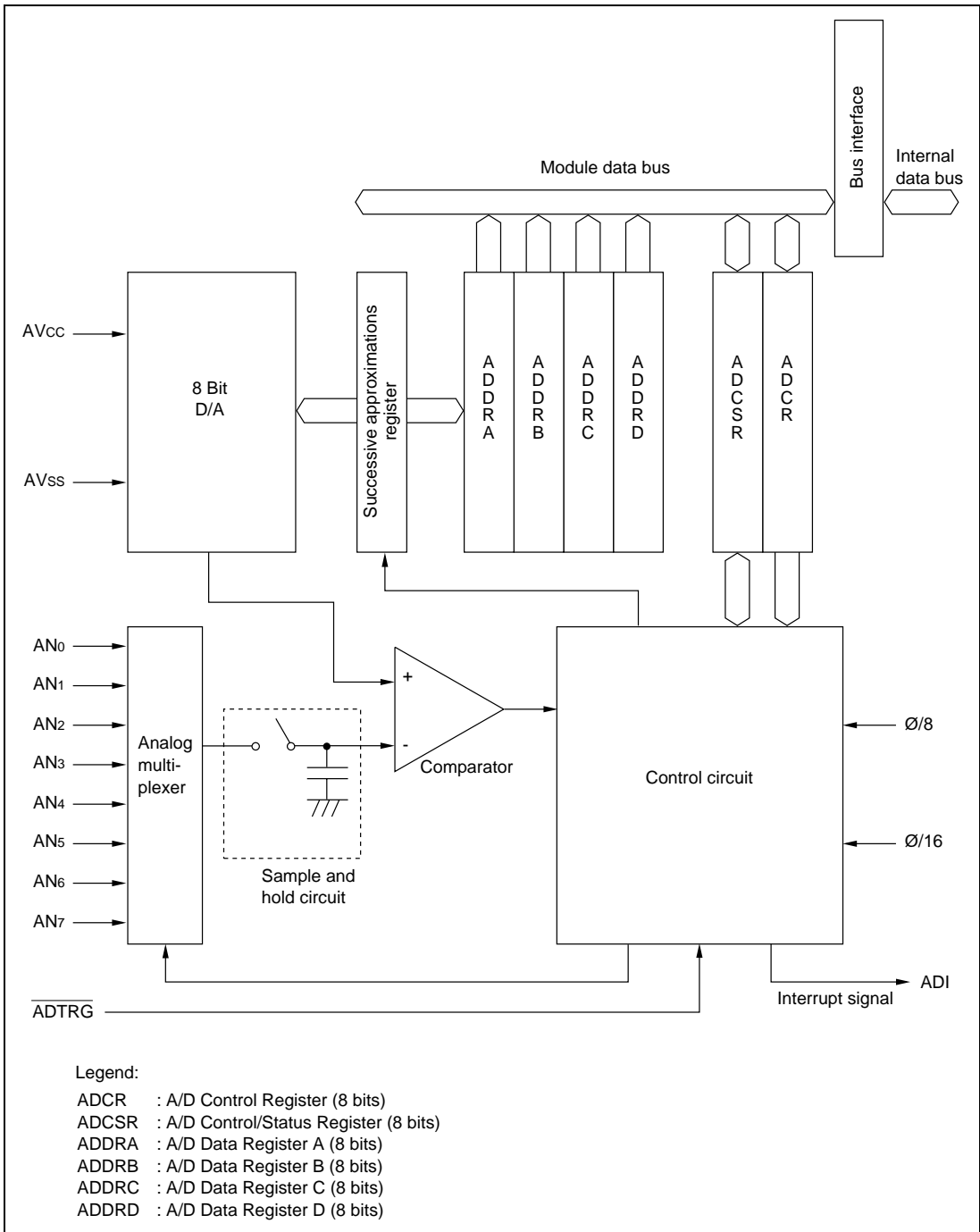

Figure 11.1 Block Diagram of A/D Converter

11.1.3 Input Pins

Table 11.1 lists the input pins used by the A/D converter module.

The eight analog input pins are divided into two groups, consisting of analog inputs 0 to 3 (AN₀ to AN₃) and analog inputs 4 to 7 (AN₄ to AN₇), respectively.

Table 11.1 A/D Input Pins

Name	Abbreviation	I/O	Function
Analog supply voltage	AV _{CC}	Input	Power supply and reference voltage for the analog circuits.
Analog ground	AV _{SS}	Input	Ground and reference voltage for the analog circuits.
Analog input 0	AN ₀	Input	Analog input pins, group 0
Analog input 1	AN ₁	Input	
Analog input 2	AN ₂	Input	
Analog input 3	AN ₃	Input	
Analog input 4	AN ₄	Input	Analog input pins, group 1
Analog input 5	AN ₅	Input	
Analog input 6	AN ₆	Input	
Analog input 7	AN ₇	Input	
A/D external trigger	ADTRG	Input	External trigger for starting A/D conversion

11.1.4 Register Configuration

Table 11.2 lists the registers of the A/D converter module.

Table 11.2 A/D Registers

Name	Abbreviation	R/W	Initial Value	Address
A/D data register A	ADDRA	R	H'00	H'FFE0
A/D data register B	ADDRB	R	H'00	H'FFE2
A/D data register C	ADDRC	R	H'00	H'FFE4
A/D data register D	ADDRD	R	H'00	H'FFE6
A/D control/status register	ADCSR	R/(W)*	H'00	H'FFE8
A/D control register	ADCR	R/W	H'7E	H'FFEA

Note: Software can write a "0" to clear bit 7, but cannot write a "1" in this bit.

11.2 Register Descriptions

11.2.1 A/D Data Registers (ADDR)—H'FFE0 to H'FFE6

Bit:	7	6	5	4	3	2	1	0
ADDRn:								
Initial value:	0	0	0	0	0	0	0	0
Read/Write:	R	R	R	R	R	R	R	R

(n = A to D)

The four A/D data registers (ADDRA to ADDR4) are 8-bit read-only registers that store the results of A/D conversion. Each data register is assigned to two analog input channels as indicated in table 11.3.

The A/D data registers are always readable by the CPU.

The A/D data registers are initialized to H'00 at a reset and in the standby modes.

Table 11.3 Assignment of Data Registers to Analog Input Channels

Analog Input Channel		A/D Data Register
Group 0	Group 1	
AN0	AN4	ADDRA
AN1	AN5	ADDRB
AN2	AN6	ADDRC
AN3	AN7	ADDRD

11.2.2 A/D Control/Status Register (ADCSR)—H'FFE8

Bit:	7	6	5	4	3	2	1	0
	ADF	ADIE	ADST	SCAN	CKS	CH2	CH1	CH0
Initial value:	0	0	0	0	0	0	0	0
Read/Write:	R/(W)*	R/W	R/W	R/W	R/W	R/W	R/W	R/W

Note: Software can write a "0" in bit 7 to clear the flag, but cannot write a "1" in this bit.

The A/D control/status register (ADCSR) is an 8-bit readable/writable register that controls the operation of the A/D converter module.

The ADCSR is initialized to H'00 at a reset and in the standby modes.

Bit 7—A/D End Flag (ADF): This status flag indicates the end of one cycle of A/D conversion.

Bit 7

ADF	Description
0	To clear ADF, the CPU must read ADF after it has been set to “1,” (Initial value) then write a “0” in this bit.
1	This bit is set to 1 at the following times: (1) Single mode: when one A/D conversion is completed. (2) Scan mode: when inputs on all selected channels have been converted.

Bit 6—A/D Interrupt Enable (ADIE): This bit selects whether to request an A/D interrupt (ADI) when A/D conversion is completed.

Bit 6

ADIE	Description
0	The A/D interrupt request (ADI) is disabled. (Initial value)
1	The A/D interrupt request (ADI) is enabled.

Bit 5—A/D Start (ADST): The A/D converter operates while this bit is set to “1.” This bit can be set to “1” by the external trigger signal ADTRG.

Bit 5

ADST	Description
0	A/D conversion is halted. (Initial value)
1	(1) Single mode: One A/D conversion is performed. The ADST bit is automatically cleared to “0” at the end of the conversion. (2) Scan mode: A/D conversion starts and continues cyclically on the selected channels until the ADST bit is cleared to “0” by software (or a reset, or by entry to a standby mode).

Bit 4—Scan Mode (SCAN): This bit selects the scan mode or single mode of operation. See section 11.3, “Operation” for descriptions of these modes. The mode should be changed only when the ADST bit is cleared to “0.”

Bit 4

SCAN	Description
0	Single mode (Initial value)
1	Scan mode

Bit 3—Clock Select (CKS): This bit controls the A/D conversion time.

The conversion time should be changed only when the ADST bit is cleared to “0.”

Bit 3

CKS	Description
0	Conversion time = 242 states (max) (Initial value)
1	Conversion time = 122 states (max)

Bits 2 to 0—Channel Select 2 to 0 (CH2 to CH0): These bits and the SCAN bit combine to select one or more analog input channels.

The channel selection should be changed only when the ADST bit is cleared to “0.”

Group Select CH2	Channel Select		Selected Channels	
	CH1	CH0	Single Mode	Scan Mode
0	0	0	AN ₀ (Initial value)	AN ₀
	0	1	AN ₁	AN ₀ , AN ₁
	1	0	AN ₂	AN ₀ to AN ₂
	1	1	AN ₃	AN ₀ to AN ₃
1	0	0	AN ₄	AN ₄
	0	1	AN ₅	AN ₄ , AN ₅
	1	0	AN ₆	AN ₄ to AN ₆
	1	1	AN ₇	AN ₄ to AN ₇

11.2.3 A/D Control Register (ADCR)—H'FFEA

Bit:	7	6	5	4	3	2	1	0
	TRGE	—	—	—	—	—	—	CHS
Initial value:	0	1	1	1	1	1	1	0
Read/Write:	R/W	—	—	—	—	—	—	R/W

The A/D control register (ADCR) is an 8-bit readable/writable register that enables or disables the A/D external trigger signal.

The ADCR is initialized to H'7E at a reset and in the standby modes.

Bit 7—Trigger Enable (TRGE): This bit enables the ADTRG (A/D external trigger) signal to set the ADST bit and start A/D conversion.

Bit 7

TRGE	Description
0	A/D external trigger is disabled. $\overline{\text{ADTRG}}$ does not set the ADST bit. (Initial value)
1	A/D external trigger is enabled. $\overline{\text{ADTRG}}$ sets the ADST bit. (The ADST bit can also be set by software.)

Bits 6 to 1—Reserved: These bits cannot be modified and are always read as “1.”

Bit 0—Channel Set Select (CHS): This bit is reserved. It does not affect any operation in the H8/338 Series.

11.3 Operation

The A/D converter performs 8 successive approximations to obtain a result ranging from H'00 (corresponding to AV_{SS}) to H'FF (corresponding to AV_{CC}).

The A/D converter module can be programmed to operate in single mode or scan mode as explained below.

11.3.1 Single Mode (SCAN = 0)

The single mode is suitable for obtaining a single data value from a single channel. A/D conversion starts when the ADST bit is set to "1," either by software or by a High-to-Low transition of the ADTRG signal (if enabled). During the conversion process the ADST bit remains set to "1." When conversion is completed, the ADST bit is automatically cleared to "0."

When the conversion is completed, the ADF bit is set to "1." If the interrupt enable bit (ADIE) is also set to "1," an A/D conversion end interrupt (ADI) is requested, so that the converted data can be processed by an interrupt-handling routine. The ADF bit is cleared when software reads the A/D control/status register (ADCSR), then writes a "0" in this bit.

Before selecting the single mode, clock, and analog input channel, software should clear the ADST bit to "0" to make sure the A/D converter is stopped. Changing the mode, clock, or channel selection while A/D conversion is in progress can lead to conversion errors. A/D conversion begins when the ADST bit is set to "1" again. The same instruction can be used to alter the mode and channel selection and set ADST to "1."

The following example explains the A/D conversion process in single mode when channel 1 (AN1) is selected and the external trigger is disabled. Figure 11.2 shows the corresponding timing chart.

- (1) Software clears the ADST bit to "0," then selects the single mode (SCAN = "0") and channel 1 (CH2 to CH0 = "001"), enables the A/D interrupt request (ADIE = "1"), and sets the ADST bit to "1" to start A/D conversion.

Coding Example: (when using the slow clock, CKS = "0")

```
BCLR #5, @H'FFE8           ;Clear ADST
MOV.B #H'7F, ROL
MOV.B ROL, @H'FFEA        ;Disable external trigger
MOV.B #H'61, ROL
MOV.B ROL, @H'FFE8        ;Select mode and channel and set ADST to "1"
```

Value set in ADCSR

ADF	ADIE	ADST	SCAN	CKS	CH2	CH1	CH0
0	1	1	0	0	0	0	1

- (2) The A/D converter converts the voltage level at the AN1 input pin to a digital value. At the end of the conversion process the A/D converter transfers the result to register ADDR0, sets the ADF bit to “1,” clears the ADST bit to “0,” and halts.
- (3) ADF = “1” and ADIE = “1,” so an A/D interrupt is requested.
- (4) The user-coded A/D interrupt-handling routine is started.
- (5) The interrupt-handling routine reads the ADCSR value, then writes a “0” in the ADF bit to clear this bit to “0.”
- (6) The interrupt-handling routine reads and processes the A/D conversion result (ADDR0).
- (7) The routine ends.

Steps (2) to (7) can now be repeated by setting the ADST bit to “1” again.

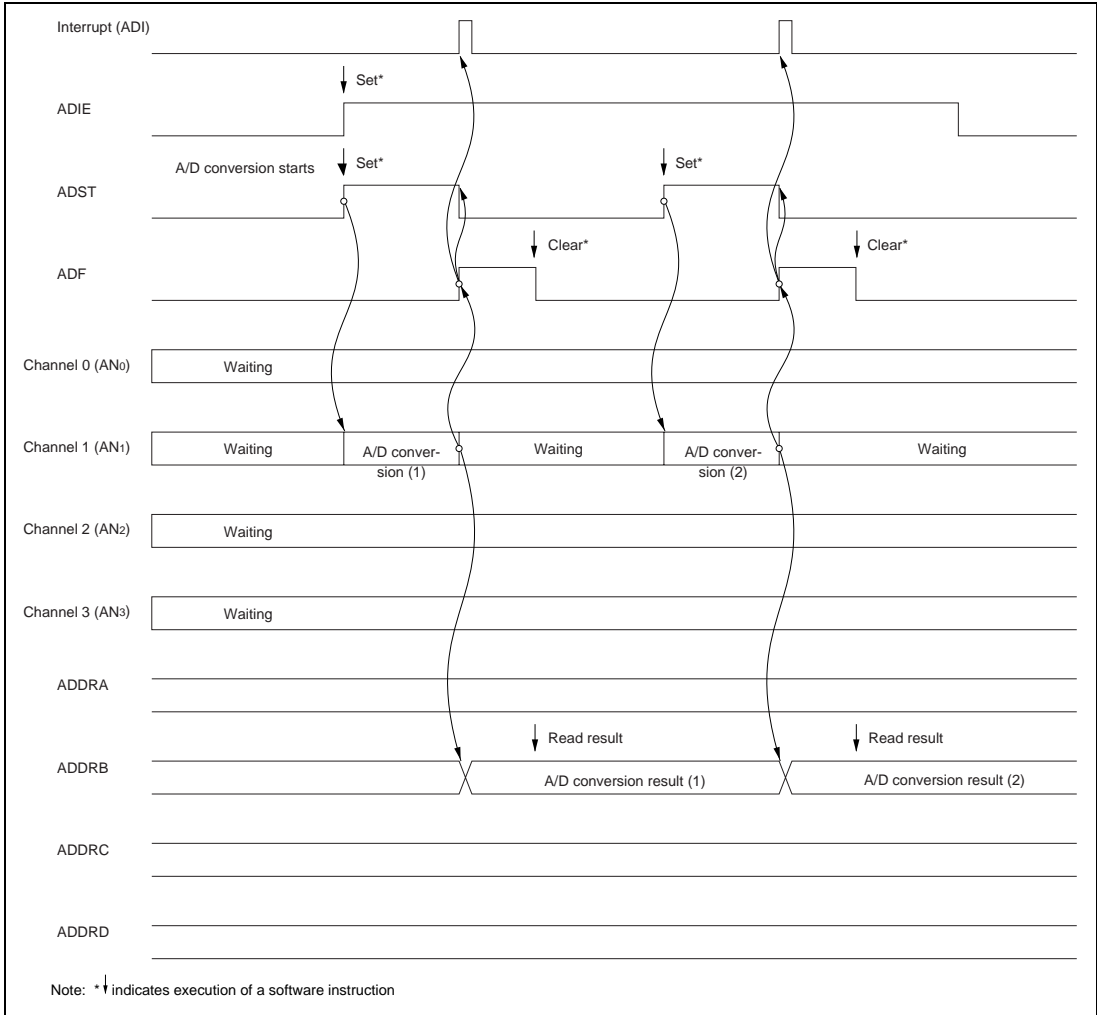

Figure 11.2 A/D Operation in Single Mode (when Channel 1 is Selected)

11.3.2 Scan Mode (SCAN = 1)

The scan mode can be used to monitor analog inputs on one or more channels. When the ADST bit is set to “1,” either by software or by a High-to-Low transition of the ADTRG signal (if enabled), A/D conversion starts from the first channel selected by the CH bits. When CH2 = “0” the first channel is AN₀. When CH2 = “1” the first channel is AN₄.

If the scan group includes more than one channel (i.e., if bit CH1 or CH0 is set), conversion of the next channel (AN₁ or AN₅) begins as soon as conversion of the first channel ends.

Conversion of the selected channels continues cyclically until the ADST bit is cleared to “0.” The conversion results are placed in the data registers corresponding to the selected channels. The A/D data registers are readable by the CPU.

Before selecting the scan mode, clock, and analog input channels, software should clear the ADST bit to “0” to make sure the A/D converter is stopped. Changing the mode, clock, or channel selection while A/D conversion is in progress can lead to conversion errors. A/D conversion begins from the first selected channel when the ADST bit is set to “1” again. The same instruction can be used to alter the mode and channel selection and set ADST to “1.”

The following example explains the A/D conversion process when three channels in group 0 are selected (AN₀, AN₁, and AN₂) and the external trigger is disabled. Figure 11.3 shows the corresponding timing chart.

- (1) Software clears the ADST bit to “0,” then selects the scan mode (SCAN = “1”), scan group 0 (CH2 = “0”), and analog input channels AN₀ to AN₂ (CH1 = “1” and CH0 = “0”) and sets the ADST bit to “1” to start A/D conversion.

Coding Example: (with slow clock and ADI interrupt enabled)

```
BCLR #5, @H'FFE8           ;Clear ADST
MOV.B #H'7F, ROL
MOV.B ROL, @H'FFEA        ;Disable external trigger
MOV.B #H'72, ROL
MOV.B ROL, @H'FFE8        ;Select mode and channels and set ADST to “1”
Value set in ADCSR
```

ADF	ADIE	ADST	SCAN	CKS	CH2	CH1	CH0
0	1	1	1	0	0	1	0

- (2) The A/D converter converts the voltage level at the AN₀ input pin to a digital value, and transfers the result to register ADDRA.
- (3) Next the A/D converter converts AN₁ and transfers the result to ADDR_B. Then it converts AN₂ and transfers the result to ADDR_C.

(4) After all selected channels (AN_0 to AN_2) have been converted, the AD converter sets the ADF bit to “1.” If the ADIE bit is set to “1,” an A/D interrupt (ADI) is requested. Then the A/D converter begins converting AN_0 again.

(5) Steps (2) to (4) are repeated cyclically as long as the ADST bit remains set to “1.”

To stop the A/D converter, software must clear the ADST bit to “0.”

Regardless of which channel is being converted when the ADST bit is cleared to “0,” when the ADST bit is set to “1” again, conversion begins from the first selected channel (AN_0).

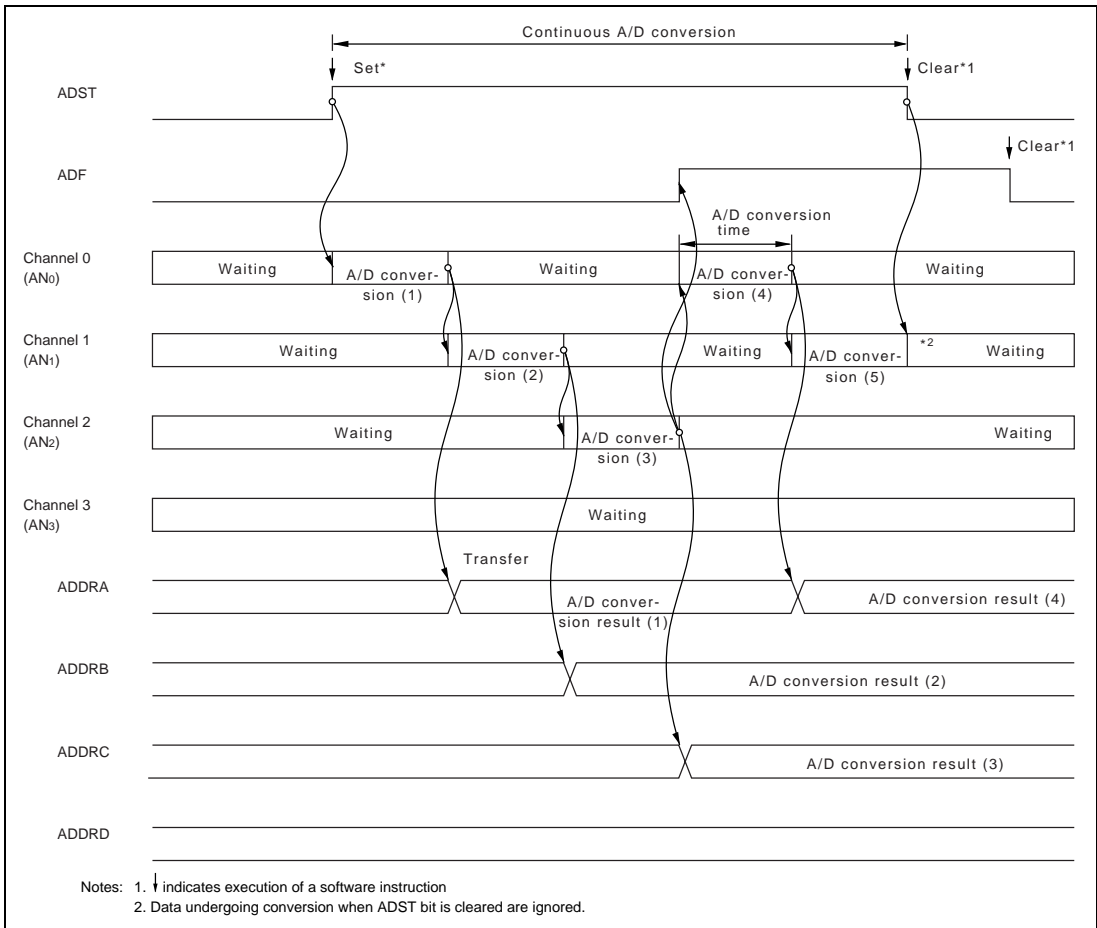

Figure 11.3 A/D Operation in Scan Mode (when Channels 0 to 2 are Selected)

11.3.3 Input Sampling Time and A/D Conversion Time

The A/D converter includes a built-in sample-and-hold circuit. Sampling of the input starts at a time t_D after the ADST bit is set to “1.” The sampling process lasts for a time t_{SPL} . The actual A/D conversion begins after sampling is completed. Figure 11.4 shows the timing of these steps.

Table 11.4 (a) lists the conversion times for the single mode. Table 11.4 (b) lists the conversion times for the scan mode.

The total conversion time (t_{CONV}) includes t_D and t_{SPL} . The purpose of t_D is to synchronize the ADCSR write time with the A/D conversion process, so the length of t_D is variable. The total conversion time therefore varies within the minimum to maximum ranges indicated in table 11.4 (a) and (b).

In the scan mode, the ranges given in table 11.4 (b) apply to the first conversion. The length of the second and subsequent conversion processes is fixed at 256 states (when CKS = “0”) or 128 states (when CKS = “1”).

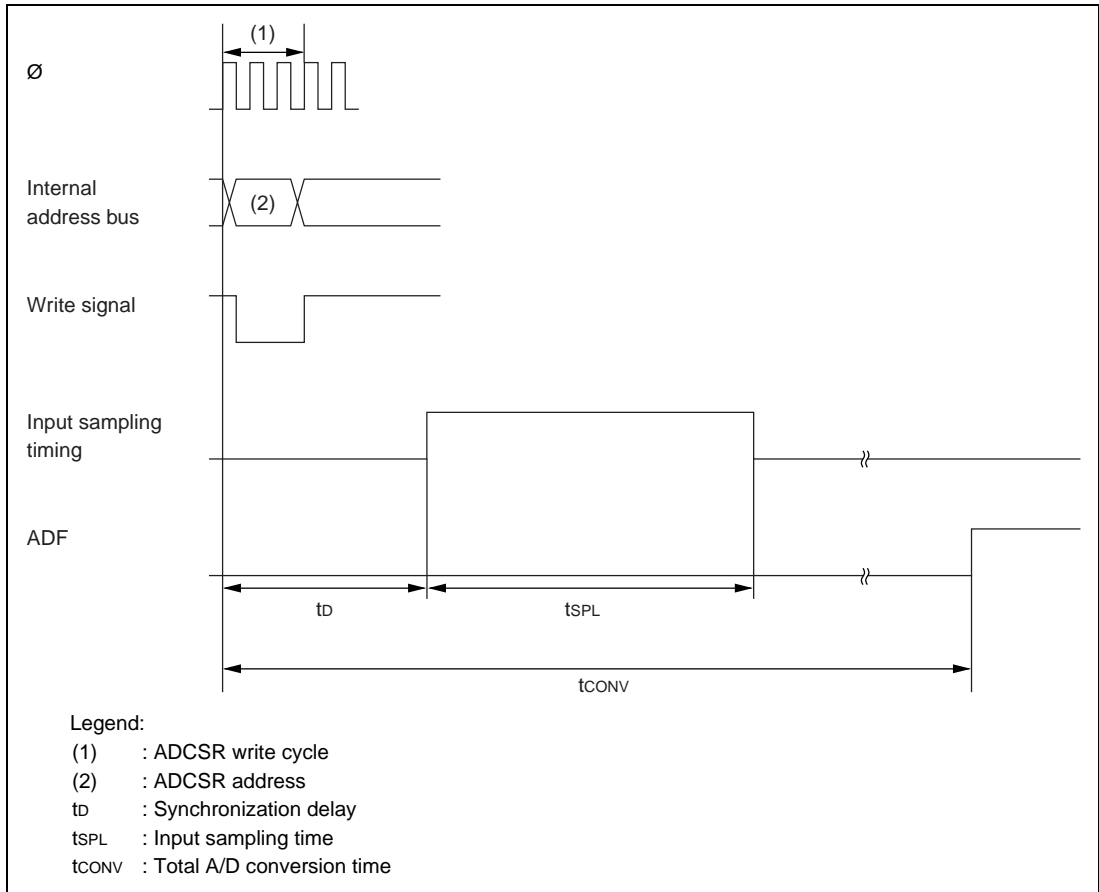

Figure 11.4 A/D Conversion Timing

Table 11.4 (a) A/D Conversion Time (Single mode)

Item	Symbol	CKS = "0"			CKS = "1"		
		Min	Typ	Max	Min	Typ	Max
Synchronization delay	t_D	18	—	33	10	—	17
Input sampling time	t_{SPL}	—	63	—	—	31	—
Total A/D conversion time	t_{CONV}	227	—	242	115	—	122

Table 11.4 (b) A/D Conversion Time (Scan mode)

Item	Symbol	CKS = "0"			CKS = "1"		
		Min	Typ	Max	Min	Typ	Max
Synchronization delay	t_D	18	—	33	10	—	17
Input sampling time	t_{SPL}	—	63	—	—	31	—
Total A/D conversion time	t_{CONV}	259	—	274	131	—	138

Note: Values in the tables above are numbers of states.

11.3.4 External Trigger Input Timing

A/D conversion can be started by external trigger input at the ADTRG pin. This input is enabled or disabled by the TRGE bit in the A/D control register (ADCR). If the TRGE bit is set to "1," when a falling edge of ADTRG is detected the ADST bit is set to "1" and A/D conversion begins. Subsequent operation in both single and scan modes is the same as when the ADST bit is set to "1" by software.

Figure 11.5 shows the trigger timing.

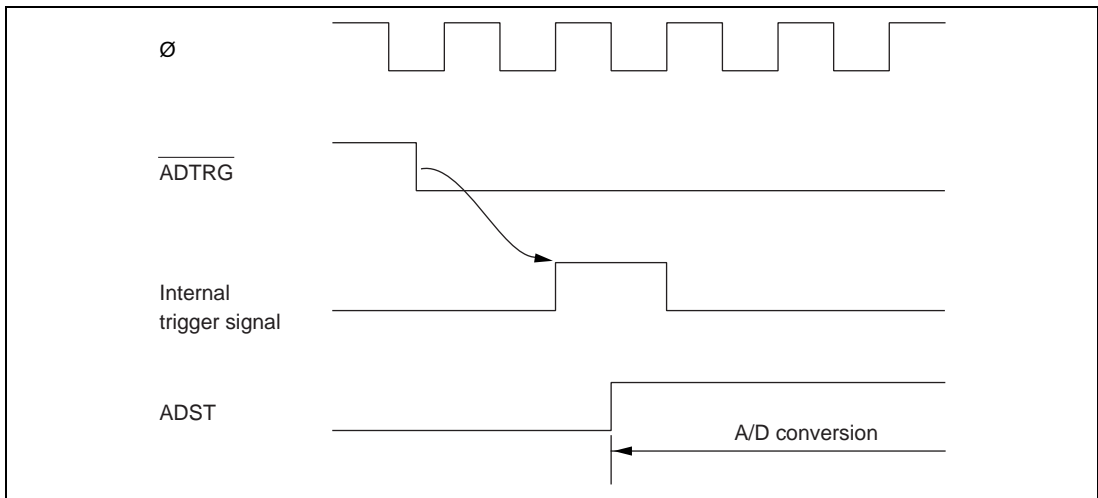

Figure 11.5 External Trigger Input Timing

11.4 Interrupts

The A/D conversion module generates an A/D-end interrupt request (ADI) at the end of A/D conversion.

The ADI interrupt request can be enabled or disabled by the ADIE bit in the A/D control/status register (ADCSR).

Section 12 D/A Converter

12.1 Overview

The H8/338 Series has an on-chip D/A converter module with two channels.

12.1.1 Features

Features of the D/A converter module are listed below.

- Eight-bit resolution
- Two-channel output
- Maximum conversion time: 10 μ s (with 30pF load capacitance)
- Output voltage: 0V to AV_{CC}

12.1.2 Block Diagram

Figure 12.1 shows a block diagram of the D/A converter.

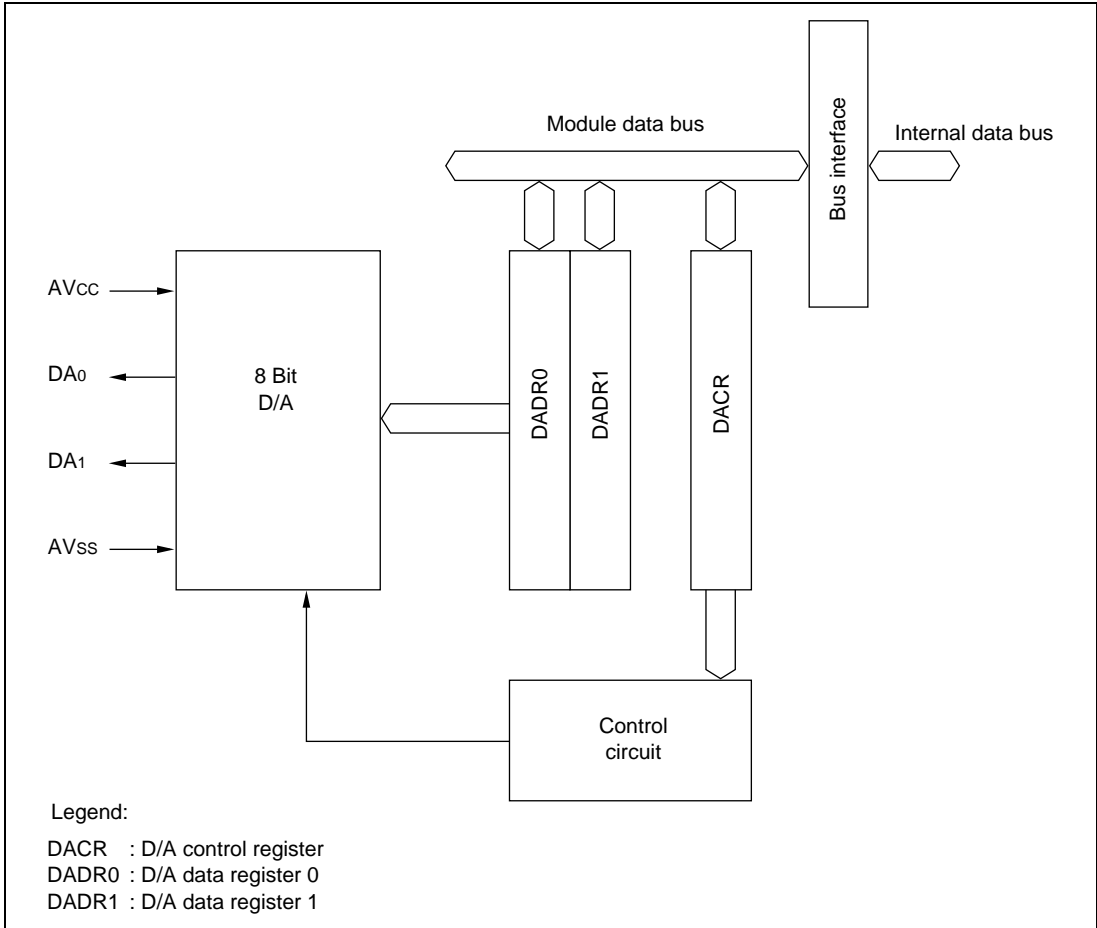

Figure 12.1 D/A Converter Block Diagram

12.1.3 Input and Output Pins

Table 12.1 lists the input and output pins used by the D/A converter module.

Table 12.1 Input and Output Pins of D/A Converter Module

Name	Abbreviation	I/O	Function
Analog supply voltage	AV _{CC}	Input	Power supply and reference voltage for analog circuits
Analog ground	AV _{SS}	Input	Ground and reference voltage for analog circuits
Analog output 0	DA ₀	Output	Analog output channel 0
Analog output 1	DA ₁	Output	Analog output channel 1

12.1.4 Register Configuration

Table 12.2 lists the three registers of the D/A converter module.

Table 12.2 D/A Converter Registers

Name	Abbreviation	R/W	Initial Value	Address
D/A data register 0	DADR0	R/W	H'00	H'FFA8
D/A data register 1	DADR1	R/W	H'00	H'FFA9
D/A control register	DACR	R/W	H'1F	H'FFAA

12.2 Register Descriptions

12.2.1 D/A Data Registers 0 and 1 (DADR0, DADR1) H'FFA8, H'FFA9

Bit:	7	6	5	4	3	2	1	0
Initial value:	0	0	0	0	0	0	0	0
Read/Write:	R/W	R/W	R/W	R/W	R/W	R/W	R/W	R/W

D/A data registers 0 and 1 (DADR0 and DADR1) are 8-bit readable and writable registers that store data to be converted. When analog output is enabled, the value in the D/A data register is converted and output continuously at the analog output pin.

The D/A data registers are initialized to H'00 at a reset and in the standby modes.

12.2.2 D/A Control Register (DACR) H'FFAA

Bit:	7	6	5	4	3	2	1	0
	DAOE1	DAOE0	DAE	—	—	—	—	—
Initial value:	0	0	0	1	1	1	1	1
Read/Write:	R/W	R/W	R/W	—	—	—	—	—

The D/A control register is an 8-bit readable and writable register that controls the operation of the D/A converter module.

The D/A control register is initialized to H'1F at a reset and in the standby modes.

Bit 7—D/A Output Enable 1 (DAOE1): Controls analog output from the D/A converter.

Bit 7 DAOE1	Description
0	Analog output at DA ₁ is disabled.
1	D/A conversion is enabled on channel 1. Analog output is enabled at DA ₁ .

Bit 6—D/A Output Enable 0 (DAOE0): Controls analog output from the D/A converter.

Bit 6

DAOE0 Description

0	Analog output at DA ₀ is disabled.
1	D/A conversion is enabled on channel 0. Analog output is enabled at DA ₀ .

Bit 5—D/A Enable (DAE): Controls analog output from the D/A converter, in combination with bits DAOE0 and DAOE1. D/A conversion is controlled independently on channels 0 and 1 when DAE = 0. Channels 0 and 1 are controlled together when DAE = 1.

Whether or not to output the converted results is always controlled independently by DAOE0 and DAOE1.

Bit 7 DAOE1	Bit 6 DAOE0	Bit 5 DAE	D/A conversion
0	0	—	Disabled on channels 0 and 1.
0	1	0	Enabled on channel 0. Disabled on channel 1.
0	1	1	Enabled on channels 0 and 1.
1	0	0	Disabled on channel 0. Enabled on channel 1.
1	0	1	Enabled on channels 0 and 1.
1	1	—	Enabled on channels 0 and 1.

When the DAE bit is set to “1,” analog power supply current drain is the same as during A/D and D/A conversion, even if the DAOE0 and DAOE1 bits in DACR and the ADST bit in ADSCR are cleared to “0.”

Bits 4 to 0—Reserved: These bits cannot be modified and are always read as “1.”

12.3 Operation

The D/A converter module has two built-in D/A converter circuits that can operate independently.

D/A conversion is performed continuously whenever enabled by the D/A control register. When a new value is written in DADR0 or DADR1, conversion of the new value begins immediately. The converted result is output by setting the DAOE0 or DAOE1 bit to “1.”

An example of conversion on channel 0 is given next. Figure 12.2 shows the timing.

- (1) Software writes the data to be converted in DADR0.
- (2) D/A conversion begins when the DAOE0 bit in DACR is set to “1.” After a conversion delay, analog output appears at the DA0 pin. The output value is $AVCC \times (\text{DADR0 value})/256$.
This output continues until a new value is written in DADR0 or the DAOE0 bit is cleared to 0.
- (3) If a new value is written in DADR0, conversion begins immediately. Output of the converted result begins after the conversion delay time.
- (4) When the DAOE0 bit is cleared to 0, DA0 becomes an input pin.

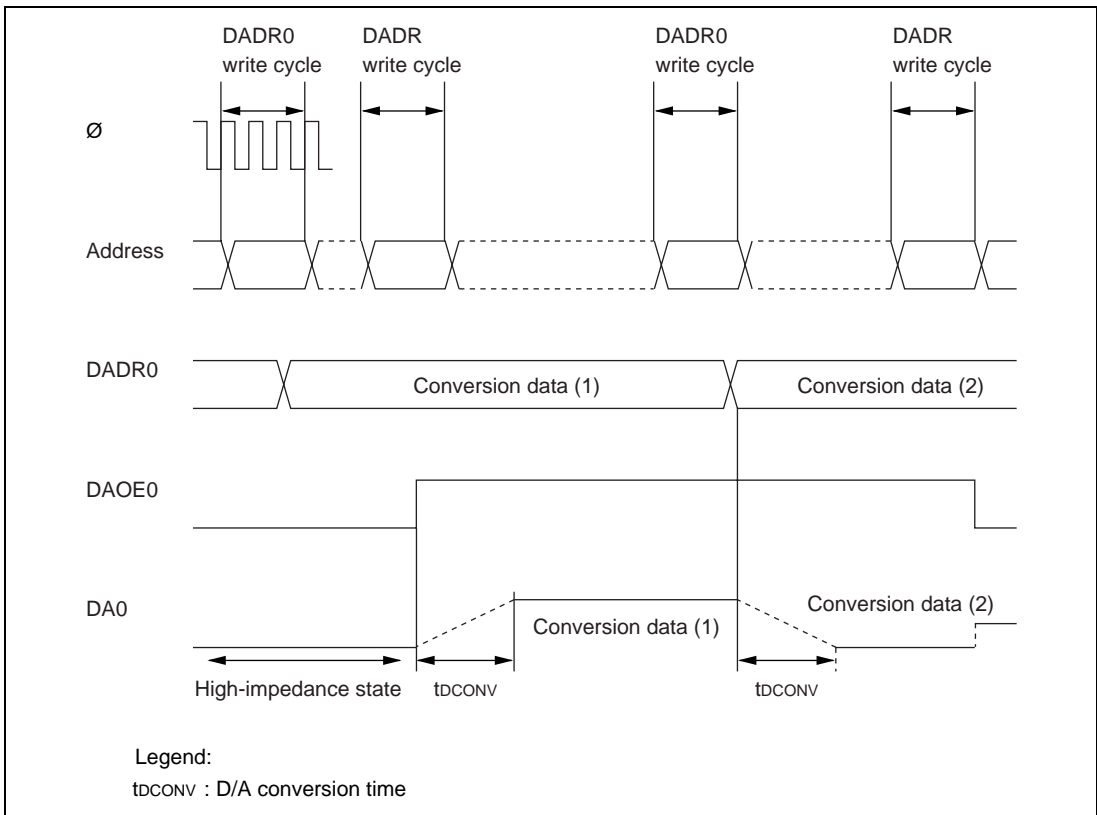

Figure 12.2 D/A Conversion (Example)

Section 13 RAM

13.1 Overview

The H8/338 includes 2k bytes of on-chip static RAM. The H8/337 and H8/336 have 1k byte. The RAM is connected to the CPU by a 16-bit data bus. Both byte and word access to the on-chip RAM are performed in two states, enabling rapid data transfer and instruction execution.

The on-chip RAM is assigned to addresses H'F780 to H'FF7F in the address space of the H8/338, and addresses H'FB80 to H'FF7F in the address space of the H8/337 and H8/336. The RAME bit in the system control register (SYSCR) can enable or disable the on-chip RAM, permitting these addresses to be allocated to external memory instead, if so desired.

13.2 Block Diagram

Figure 13.1 is a block diagram of the on-chip RAM.

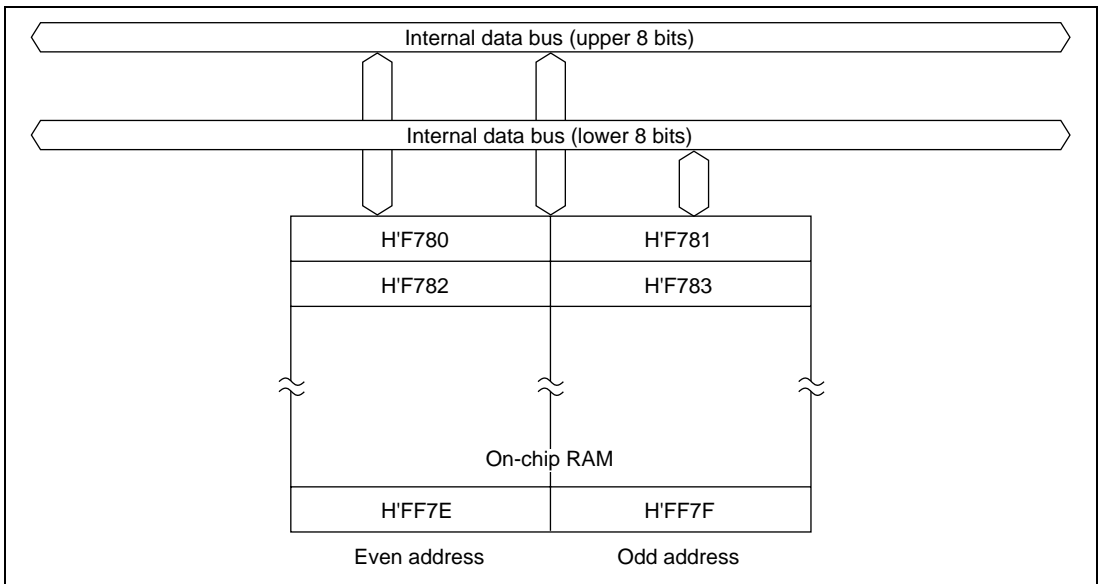

Figure 13.1 Block Diagram of On-Chip RAM (H8/338)

13.3 RAM Enable Bit (RAME) in System Control Register (SYSCR)

The on-chip RAM is enabled or disabled by the RAME (RAM Enable) bit in the system control register (SYSCR).

Bit:	7	6	5	4	3	2	1	0
	SSBY	STS2	STS1	STS0	—	NMIEG	DPME	RAME
Initial value:	0	0	0	0	1	0	0	1
Read/Write:	R/W	R/W	R/W	R/W	—	R/W	R/W	R/W

The only bit in the system control register that concerns the on-chip RAM is the RAME bit. See section 2.2, "System Control Register," for the other bits.

Bit 0—RAM Enable (RAME): This bit enables or disables the on-chip RAM.

The RAME bit is initialized to "1" on the rising edge of the RES signal, so a reset enables the on-chip RAM. The RAME bit is not initialized in the software standby mode.

Bit 7

RAME	Description
0	On-chip RAM is disabled.
1	On-chip RAM is enabled. (Initial value)

13.4 Operation

13.4.1 Expanded Modes (Modes 1 and 2)

If the RAME bit is set to "1," accesses to addresses H'F780 to H'FF7F in the H8/338 and addresses H'FB80 to H'FF7F in the H8/337 and H8/336 are directed to the on-chip RAM. If the RAME bit is cleared to "0," accesses to these addresses are directed to the external data bus.

13.4.2 Single-Chip Mode (Mode 3)

If the RAME bit is set to "1," accesses to addresses H'F780 to H'FF7F in the H8/338 and addresses H'FB80 to H'FF7F in the H8/337 and H8/336 are directed to the on-chip RAM.

If the RAME bit is cleared to "0," the on-chip RAM data cannot be accessed. Attempted write access has no effect. Attempted read access always results in H'FF data being read.

Section 14 ROM

14.1 Overview

The H8/338 includes 48k bytes of high-speed, on-chip ROM. The H8/337 has 32k bytes. The H8/336 has 24k bytes. The on-chip ROM is connected to the CPU via a 16-bit data bus. Both byte data and word data are accessed in two states, enabling rapid data transfer and instruction fetching.

The on-chip ROM is enabled or disabled depending on the MCU operating mode, which is determined by the inputs at the mode pins (MD_1 and MD_0). See table 14.1.

Table 14.1 On-Chip ROM Usage in Each MCU Mode

Mode	Mode Pins		On-chip ROM
	MD_1	MD_0	
Mode 1 (expanded mode)	0	1	Disabled (external addresses)
Mode 2 (expanded mode)	1	0	Enabled
Mode 3 (single-chip mode)	1	1	Enabled

The H8/338 and H8/337 are available with electrically programmable ROM (PROM), or with masked ROM. The PROM version has a PROM mode in which the chip can be programmed with a standard PROM writer.

14.1.1 Block Diagram

Figure 14.1 is a block diagram of the on-chip ROM.

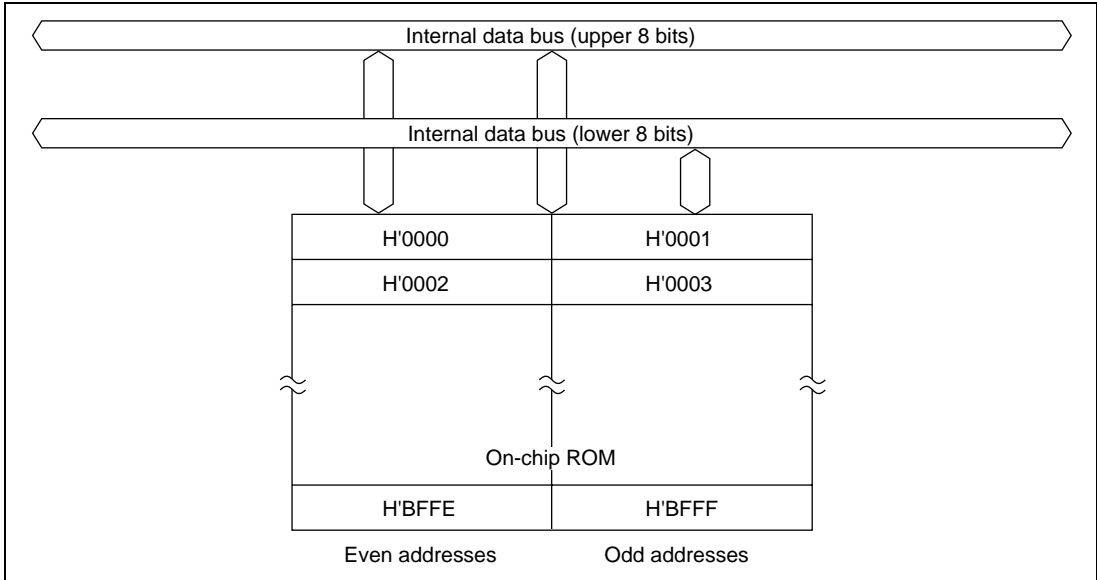

Figure 14.1 Block Diagram of On-Chip ROM (H8/338)

14.2 PROM Mode (H8/338, H8/337)

14.2.1 PROM Mode Setup

In the PROM mode of the PROM version of the H8/338 and H8/337, the usual microcomputer functions are halted to allow the on-chip PROM to be programmed. The programming method is the same as for the HN27C101.

To select the PROM mode, apply the signal inputs listed in table 14.2.

Table 14.2 Selection of PROM Mode

Pin	Input
Mode pin MD ₁	Low
Mode pin MD ₀	Low
$\overline{\text{STBY}}$ pin	Low
Pins P6 ₃ and P6 ₄	High

14.2.2 Socket Adapter Pin Assignments and Memory Map

The H8/338 and H8/337 can be programmed with a general-purpose PROM writer by using a socket adapter to change the pin-out to 32 pins. There are different socket adapters for different packages as listed in table 14.3. The same socket adapters can be used for both the H8/338 and H8/337. Figure 14.2 shows the socket adapter pin assignments.

Table 14.3 Socket Adapters

Package	Socket Adapter
84-pin PLCC	HS338ESC02H
84-pin windowed LCC	HS338ESG02H
80-pin QFP	HS338ESH02H

The PROM size is 48k bytes for the H8/338 and 32k bytes for the H8/337. Figures 14.3 and 14.4 show memory maps of the H8/338 and H8/337 in PROM mode. HFF data should be specified for unused address areas in the on-chip PROM.

When programming with a PROM writer, limit the program address range to H'0000 to H'BFFF for the H8/338 and H'0000 to H'7FFF for the H8/337. Specify H'FF data for addresses H'C000 and above (H8/338) or H'8000 and above (H8/337). If these addresses are programmed by mistake, it may become impossible to program or verify the PROM data. The same problem may occur if an attempt is made to program the chip in page programming mode. Particular care is required with a plastic package, since the programmed data cannot be erased.

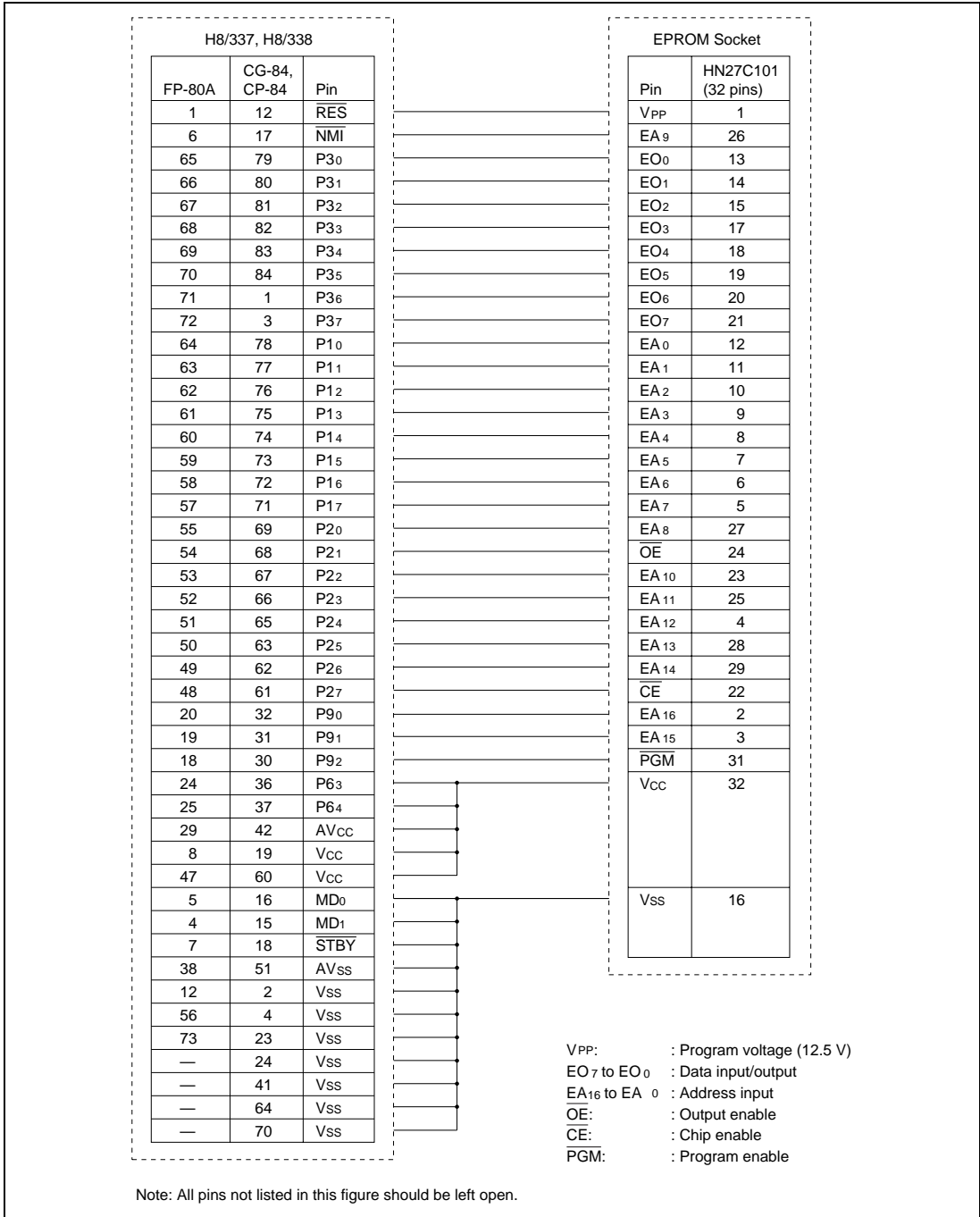

Figure 14.2 Socket Adapter Pin Assignments

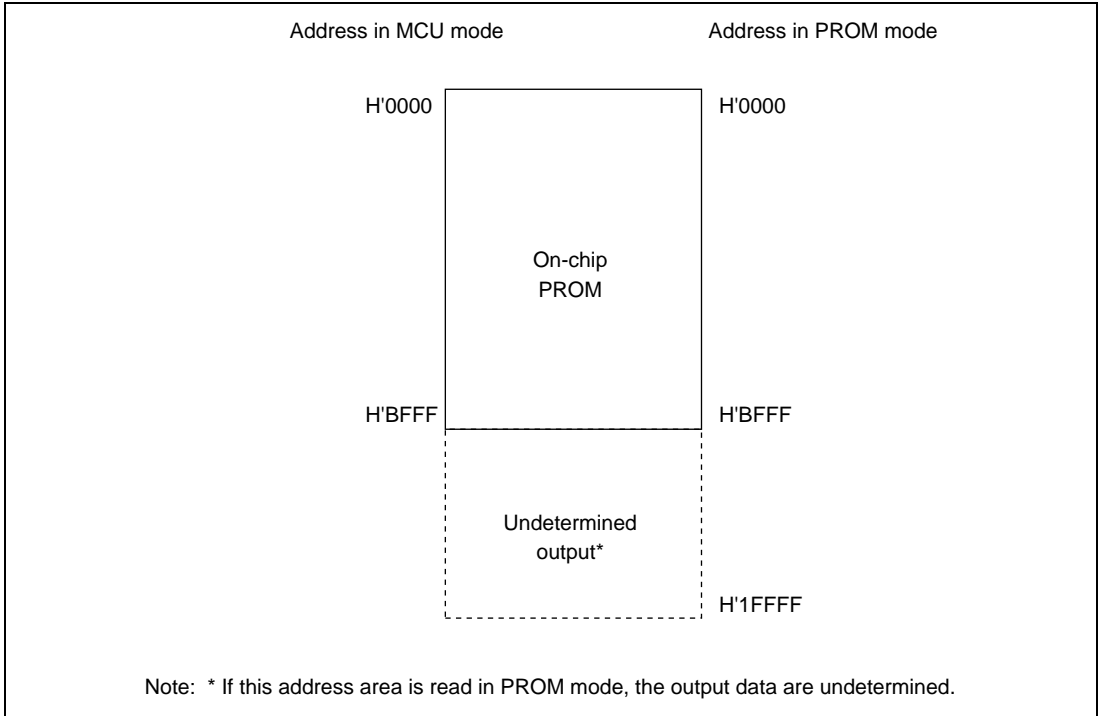

Figure 14.3 H8/338 Memory Map in PROM Mode

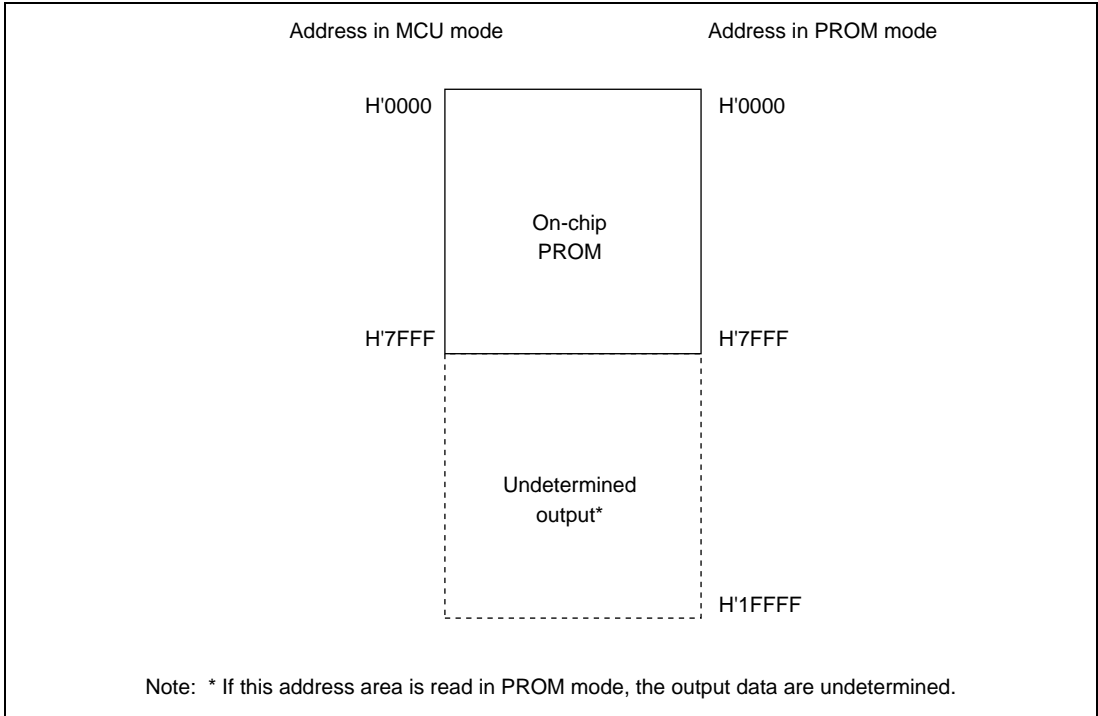

Figure 14.4 H8/337 Memory Map in PROM Mode

14.3 Programming

The write, verify, and other sub-modes of the PROM mode are selected as shown in table 14.4.

Table 14.4 Selection of Sub-Modes in PROM Mode

Sub-Mode	$\overline{\text{CE}}$	$\overline{\text{OE}}$	$\overline{\text{PGM}}$	V_{PP}	V_{CC}	EO_7 to EO_0	EA_{16} to EA_0
Write	Low	High	Low	V_{PP}	V_{CC}	Data input	Address input
Verify	Low	Low	High	V_{PP}	V_{CC}	Data output	Address input
Programming inhibited	Low	Low	Low	V_{PP}	V_{CC}	High impedance	Address input
	Low	High	High				
	High	Low	Low				
	High	High	High				

Note: The V_{PP} and V_{CC} pins must be held at the V_{PP} and V_{CC} voltage levels.

The H8/338 or H8/337 PROM has the same standard read/write specifications as the HN27C101 EPROM. Page programming is not supported, however, so do not select page programming mode. PROM writers that provide only page programming cannot be used. When selecting a PROM writer, check that it supports the byte-at-a-time high-speed programming mode. Be sure to set the address range to H'0000 to H'BFFF for the H8/338, and to H'0000 to H'7FFF for the H8/337.

14.3.1 Writing and Verifying

An efficient, high-speed programming procedure can be used to write and verify PROM data. This procedure writes data quickly without subjecting the chip to voltage stress and without sacrificing data reliability. It leaves the data H'FF written in unused addresses.

Figure 14.5 shows the basic high-speed programming flowchart.

Tables 14.5 and 14.6 list the electrical characteristics of the chip in the PROM mode. Figure 14.6 shows a write/verify timing chart.

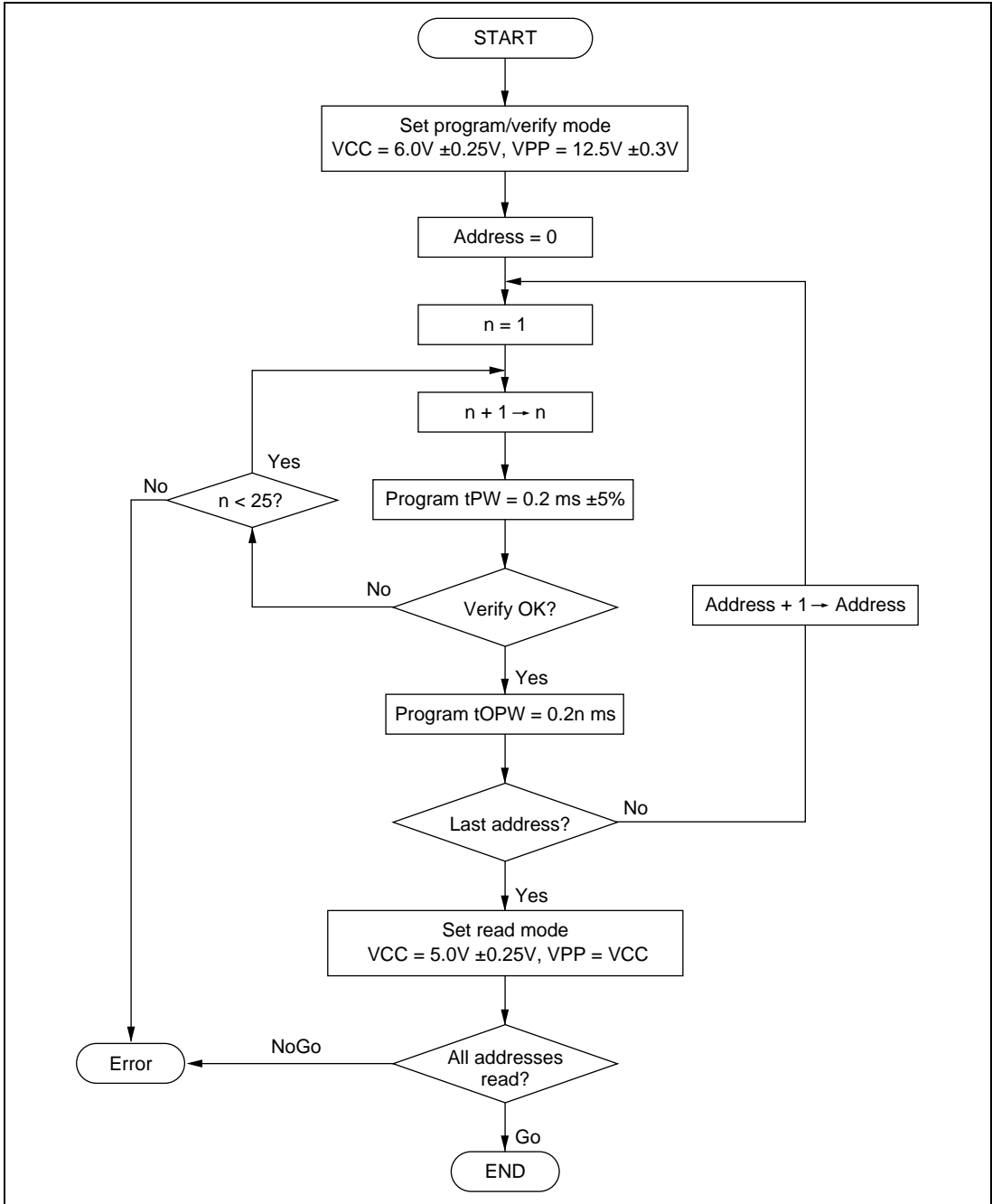

Figure 14.5 High-Speed Programming Flowchart

Table 14.5 DC Characteristics(when $V_{CC} = 6.0V \pm 0.25V$, $V_{PP} = 12.5V \pm 0.3V$, $V_{SS} = 0V$, $T_a = 25^\circ C \pm 5^\circ C$)

Item		Symbol	Min	Typ	Max	Unit	Measurement Conditions
Input High voltage	$EO_7 - EO_0,$ $A_{16} - A_0,$ $\overline{OE}, \overline{CE}, PGM$	V_{IH}	2.4	—	$V_{CC} + 0.3$	V	
Input Low voltage	$EO_7 - EO_0,$ $A_{16} - A_0,$ $\overline{OE}, \overline{CE}, PGM$	V_{IL}	-0.3	—	0.8	V	
Output High voltage	$EO_7 - EO_0$	V_{OH}	2.4	—	—	V	$I_{OH} = -200\mu A$
Output Low voltage	$EO_7 - EO_0$	V_{OL}	—	—	0.45	V	$I_{OL} = 1.6mA$
Input leakage current	$EO_7 - EO_0,$ $EA_{16} - EA_0,$ $\overline{OE}, \overline{CE}, PGM$	$ I_{LI} $	—	—	2	μA	$V_{in} = 5.25V/0.5V$
V_{CC} current		I_{CC}	—	—	40	mA	
V_{PP} current		I_{PP}	—	—	40	mA	

Table 14.6 AC Characteristics(when $V_{CC} = 6.0V \pm 0.25V$, $V_{PP} = 12.5V \pm 0.3V$, $T_a = 25^\circ C \pm 5^\circ C$)

Item	Symbol	Min	Typ	Max	Unit	Measurement Conditions
Address setup time	t_{AS}	2	—	—	μs	See figure 14.6*
\overline{OE} setup time	t_{OES}	2	—	—	μs	
Data setup time	t_{DS}	2	—	—	μs	
Address hold time	t_{AH}	0	—	—	μs	
Data hold time	t_{DH}	2	—	—	μs	
Data output disable time	t_{DF}	—	—	130	ns	
V_{PP} setup time	t_{VPS}	2	—	—	μs	
Program pulse width	t_{PW}	0.19	0.20	0.21	ms	

Note: Input pulse level: 0.8V to 2.2V

Input rise/fall time $\leq 20ns$

Timing reference levels: input—1.0V, 2.0V; output—0.8V, 2.0V

Table 14.6. AC Characteristics (cont)

(when $V_{CC} = 6.0V \pm 0.25V$, $V_{PP} = 12.5V \pm 0.3V$, $T_a = 25^\circ C \pm 5^\circ C$)

Item	Symbol	Min	Typ	Max	Unit	Measurement Conditions
\overline{OE} pulse width for overwrite-programming	t_{OPW}	0.19	—	5.25	ms	See figure 14.6*
V_{CC} setup time	t_{VCS}	2	—	—	μs	
\overline{CE} setup time	t_{CES}	2	—	—	μs	
Data output delay time	t_{OE}	0	—	150	ns	

Note: Input pulse level: 0.8V to 2.2V

Input rise/fall time $\leq 20ns$

Timing reference levels: input—1.0V, 2.0V; output—0.8V, 2.0V

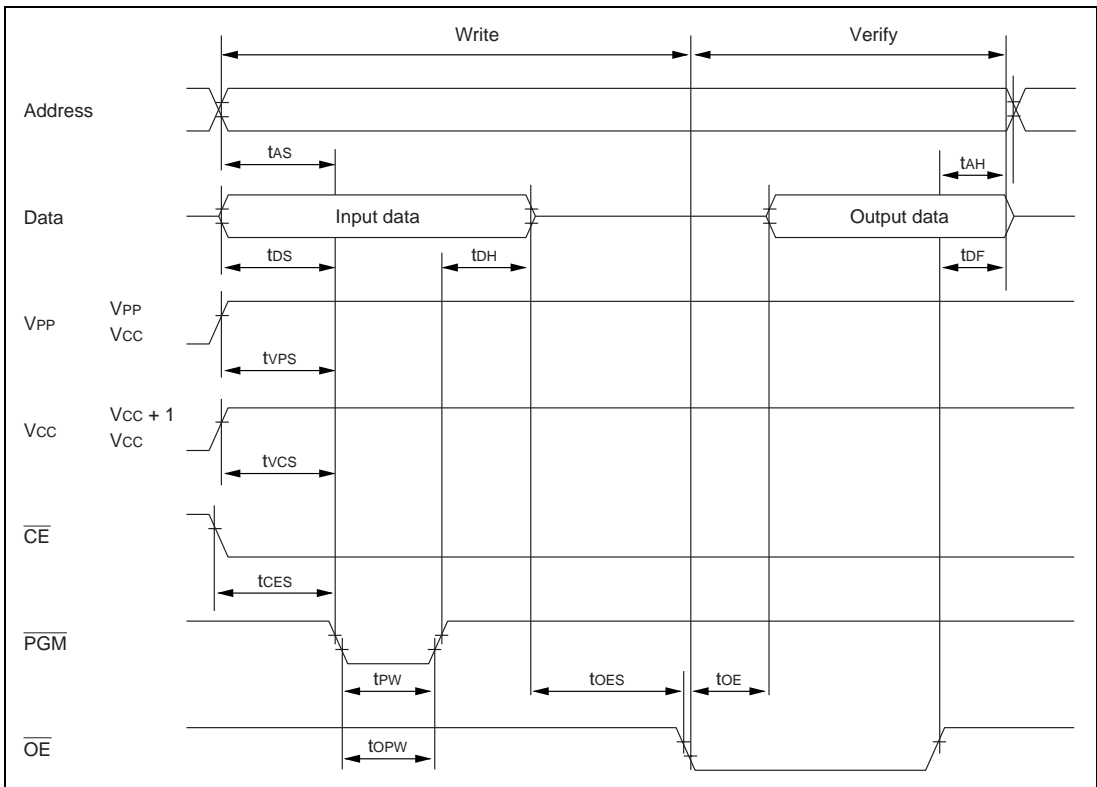

Figure 14.6 PROM Write/Verify Timing

14.3.2 Notes on Writing

(1) Write with the specified voltages and timing. The programming voltage (V_{PP}) is 12.5V.

Caution: Applied voltages in excess of the specified values can permanently destroy the chip. Be particularly careful about the PROM writer's overshoot characteristics.

If the PROM writer is set to HN27C101 specifications, V_{PP} will be 12.5V.

(2) Before writing data, check that the socket adapter and chip are correctly mounted in the PROM writer. Overcurrent damage to the chip can result if the index marks on the PROM writer, socket adapter, and chip are not correctly aligned.

(3) Don't touch the socket adapter or chip while writing. Touching either of these can cause contact faults and write errors.

(4) Page programming is not supported. Do not select page programming mode.

(5) The H8/338 PROM size is 48K bytes. The H8/337 PROM size is 32K bytes. Set the address range to H'0000 to H'BFFF for the H8/338, and to H'0000 to H'7FFF for the H8/337. When programming, specify H'FF data for unused address areas (H'C000 to H'1FFFF in the H8/338, H'8000 to H'1FFFF in the H8/337).

14.3.3 Reliability of Written Data

An effective way to assure the data holding characteristics of the programmed chips is to bake them at 150°C, then screen them for data errors. This procedure quickly eliminates chips with PROM memory cells prone to early failure.

Figure 14.7 shows the recommended screening procedure.

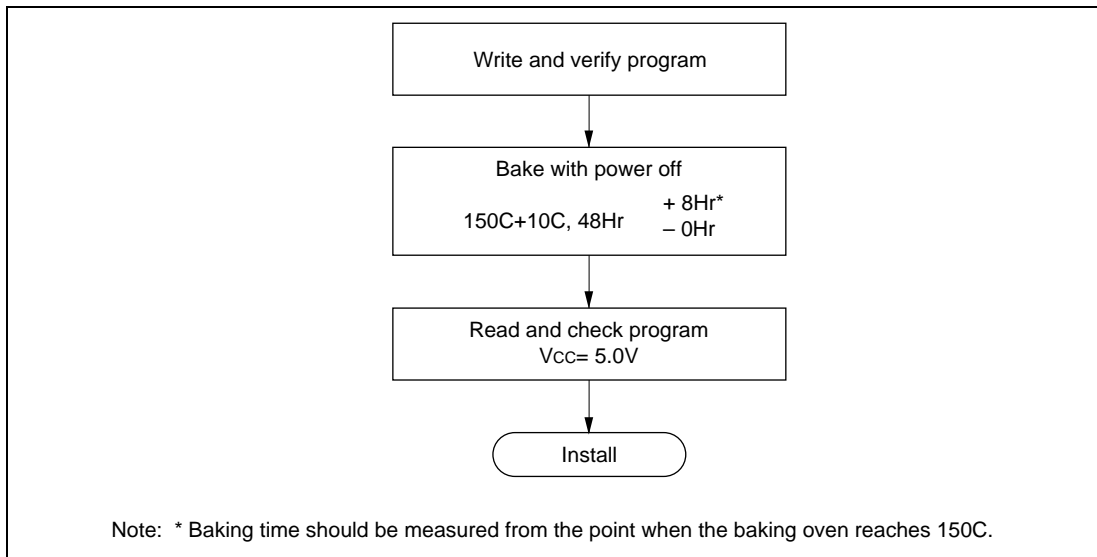

Figure 14.7 Recommended Screening Procedure

If a series of write errors occurs while the same PROM writer is in use, stop programming and check the PROM writer and socket adapter for defects, using a microcomputer chip with a windowed package and on-chip EPROM.

Please inform Hitachi of any abnormal conditions noted during programming or in screening of program data after high-temperature baking.

14.3.4 Erasing of Data

The windowed package enables data to be erased by illuminating the window with ultraviolet light. Table 14.7 lists the erasing conditions.

Table 14.7 Erasing Conditions

Item	Value
Ultraviolet wavelength	253.7 nm
Minimum illumination	15W·s/cm ²

The conditions in table 14.7 can be satisfied by placing a 12000 μ W/cm² ultraviolet lamp 2 or 3 centimeters directly above the chip and leaving it on for about 20 minutes.

14.4 Handling of Windowed Packages

(1) Glass Erasing Window: Rubbing the glass erasing window of a windowed package with a plastic material or touching it with an electrically charged object can create a static charge on the window surface which may cause the chip to malfunction.

If the erasing window becomes charged, the charge can be neutralized by a short exposure to ultraviolet light. This returns the chip to its normal condition, but it also reduces the charge stored in the floating gates of the PROM, so it is recommended that the chip be reprogrammed afterward.

Accumulation of static charge on the window surface can be prevented by the following precautions:

- ① When handling the package, ground yourself. Don't wear gloves. Avoid other possible sources of static charge.
- ② Avoid friction between the glass window and plastic or other materials that tend to accumulate static charge.
- ③ Be careful when using cooling sprays, since they may have a slight ion content.
- ④ Cover the window with an ultraviolet-shield label, preferably a label including a conductive material. Besides protecting the PROM contents from ultraviolet light, the label protects the chip by distributing static charge uniformly.

(2) Handling after Programming: Fluorescent light and sunlight contain small amounts of ultraviolet, so prolonged exposure to these types of light can cause programmed data to invert. In addition, exposure to any type of intense light can induce photoelectric effects that may lead to chip malfunction. It is recommended that after programming the chip, you cover the erasing window with a light-proof label (such as an ultraviolet-shield label).

(3) Note on 84-Pin LCC Package: A socket should always be used when the 84-pin LCC package is mounted on a printed-circuit board. Table 14.8 lists the recommended socket.

Table 14.8 Recommended Socket for Mounting 84-Pin LCC Package

Manufacturer	Code
Sumitomo 3-M	284-1273-00-1102J

Section 15 Power-Down State

15.1 Overview

The H8/338 Series has a power-down state that greatly reduces power consumption by stopping some or all of the chip functions. The power-down state includes three modes:

- (1) Sleep mode – a software-triggered mode in which the CPU halts but the rest of the chip remains active
- (2) Software standby mode – a software-triggered mode in which the entire chip is inactive
- (3) Hardware standby mode – a hardware-triggered mode in which the entire chip is inactive

Table 15.1 lists the conditions for entering and leaving the power-down modes. It also indicates the status of the CPU, on-chip supporting modules, etc. in each power-down mode.

Table 15.1 Power-Down State

Mode	Entering Procedure	Clock	CPU	CPU Reg's.	Sup. Mod.	RAM	I/O Ports	Exiting Methods
Sleep mode	Execute SLEEP instruction	Run	Halt	Held	Run	Held	Held	<ul style="list-style-type: none"> • Interrupt • \overline{RES} • \overline{STBY}
Software standby mode	Set SSBY bit in SYSCR to "1," then execute SLEEP instruction	Halt	Halt	Held	Halt and initialized	Held	Held	<ul style="list-style-type: none"> • \overline{NMI} • $\overline{IRQ_0} - \overline{IRQ_2}$ • \overline{RES} • \overline{STBY}
Hardware standby mode	Set \overline{STBY} pin to Low level	Halt	Halt	Not held	Halt and initialized	Held	High impedance state	<ul style="list-style-type: none"> • \overline{STBY} High, then \overline{RES} Low → High

Notes: 1. SYSCR: System control register
 2. SSBY: Software standby bit

15.2 System Control Register: Power-Down Control Bits

Bits 7 to 4 of the system control register (SYSCR) concern the power-down state. Specifically, they concern the software standby mode.

Table 15.2 lists the attributes of the system control register.

Table 15.2 System Control Register

Name	Abbreviation	R/W	Initial Value	Address
System control register	SYSCR	R/W	H'09	H'FFC4

Bit:	7	6	5	4	3	2	1	0
	SSBY	STS2	STS1	STS0	—	NMIEG	DPME	RAME
Initial value:	0	0	0	0	1	0	0	1
Read/Write:	R/W	R/W	R/W	R/W	—	R/W	R/W	R/W

Bit 7—Software Standby (SSBY): This bit enables or disables the transition to the software standby mode.

On recovery from the software standby mode by an external interrupt, SSBY remains set to “1.” To clear this bit, software must write a “0.”

Bit 7

SSBY	Description
0	The SLEEP instruction causes a transition to the sleep mode. (Initial value)
1	The SLEEP instruction causes a transition to the software standby mode.

Bits 6 to 4—Standby Timer Select 2 to 0 (STS2 to STS0): These bits select the clock settling time when the chip recovers from the software standby mode by an external interrupt. During the selected time, the clock oscillator runs but clock pulses are not supplied to the CPU or the on-chip supporting modules.

Bit 6 STS2	Bit 5 STS1	Bit 4 STS0	Description
0	0	0	Settling time = 8192 states (Initial value)
0	0	1	Settling time = 16384 states
0	1	0	Settling time = 32768 states
0	1	1	Settling time = 65536 states
1	—	—	Settling time = 131072 states

When the on-chip clock pulse generator is used, the STS bits should be set to allow a settling time of at least 10ms. Table 15.3 lists the settling times selected by these bits at several clock frequencies and indicates the recommended settings.

When the chip is externally clocked, the STS bits can be set to any value. The minimum value (STS2 = STS1 = STS0 = “0”) is recommended.

Table 15.3 Times Set by Standby Timer Select Bits (Unit: ms)

STS2	STS1	STS0	Settling Time (states)	System Clock Frequency (MHz)						
				10	8	6	4	2	1	0.5
0	0	0	8192	0.8	1.0	1.3	2.0	4.1	8.2	16.4
0	0	1	16384	1.6	2.0	2.7	4.1	8.2	16.4	32.8
0	1	0	32768	3.3	4.1	5.5	8.2	16.4	32.8	65.5
0	1	1	65536	6.6	8.2	10.9	16.4	32.8	65.5	131.1
1	—	—	131072	13.1	16.4	21.8	32.8	65.5	131.1	262.1

- Notes: 1. All times are in milliseconds.
 2. Recommended values are printed in boldface.

15.3 Sleep Mode

The sleep mode provides an effective way to conserve power while the CPU is waiting for an external interrupt or an interrupt from an on-chip supporting module.

15.3.1 Transition to Sleep Mode

When the SSBY bit in the system control register is cleared to “0,” execution of the SLEEP instruction causes a transition from the program execution state to the sleep mode. After executing the SLEEP instruction, the CPU halts, but the contents of its internal registers remain unchanged. The on-chip supporting modules continue to operate normally.

15.3.2 Exit from Sleep Mode

The chip wakes up from the sleep mode when it receives an internal or external interrupt request, or a Low input at the RES or STBY pin.

(1) Wake-Up by Interrupt: An interrupt releases the sleep mode and starts the CPU’s interrupt-handling sequence.

If an interrupt from an on-chip supporting module is disabled by the corresponding enable/disable bit in the module’s control register, the interrupt cannot be requested, so it cannot wake the chip up. Similarly, the CPU cannot be awoken by an interrupt other than NMI if the I (interrupt mask) bit in the CCR (condition code register) is set when the SLEEP instruction is executed.

(2) Wake-Up by $\overline{\text{RES}}$ pin: When the RES pin goes Low, the chip exits from the sleep mode to the reset state.

(3) Wake-Up by $\overline{\text{STBY}}$ pin: When the STBY pin goes Low, the chip exits from the sleep mode to the hardware standby mode.

15.4 Software Standby Mode

In the software standby mode, the system clock stops and chip functions halt, including both CPU functions and the functions of the on-chip supporting modules. Power consumption is reduced to an extremely low level. The on-chip supporting modules and their registers are reset to their initial states, but as long as a minimum necessary voltage supply is maintained (at least 2V), the contents of the CPU registers and on-chip RAM remain unchanged.

15.4.1 Transition to Software Standby Mode

To enter the software standby mode, set the standby bit (SSBY) in the system control register (SYSCR) to “1,” then execute the SLEEP instruction.

15.4.2 Exit from Software Standby Mode

The chip can be brought out of the software standby mode by an input at one of six pins: NMI, IRQ₀, IRQ₁, IRQ₂, RES, or STBY.

(1) Recovery by External Interrupt: When an NMI, IRQ₀, IRQ₁, or IRQ₂ request signal is received, the clock oscillator begins operating. After the waiting time set in the system control register (bits STS2 to STS0), clock pulses are supplied to the CPU and on-chip supporting modules. The CPU executes the interrupt-handling sequence for the requested interrupt, then returns to the instruction after the SLEEP instruction. The SSBY bit is not cleared.

See section 15.2, “System Control Register: Power-Down Control Bits,” for information about the STS bits.

Interrupts IRQ₃ to IRQ₇ should be disabled before entry to the software standby mode. Clear IRQ₃E to IRQ₇E to “0” in the interrupt enable register (IER).

(2) Recovery by $\overline{\text{RES}}$ Pin: When the RES pin goes Low, the clock oscillator starts and clock pulses are supplied to the entire chip. Next, when the RES pin goes High, the CPU begins executing the reset sequence. The SSBY bit is cleared to “0.”

The RES pin must be held Low long enough for the clock to stabilize.

(3) Recovery by $\overline{\text{STBY}}$ Pin: When the STBY pin goes Low, the chip exits from the software standby mode to the hardware standby mode.

15.4.3 Sample Application of Software Standby Mode

In this example the chip enters the software standby mode when NMI goes Low and exits when NMI goes High, as shown in figure 15.1.

The NMI edge bit (NMIEG) in the system control register is originally cleared to “0,” selecting the falling edge. When NMI goes Low, the NMI interrupt handling routine sets NMIEG to “1,” sets SSBY to “1” (selecting the rising edge), then executes the SLEEP instruction. The chip enters the software standby mode. It recovers from the software standby mode on the next rising edge of NMI.

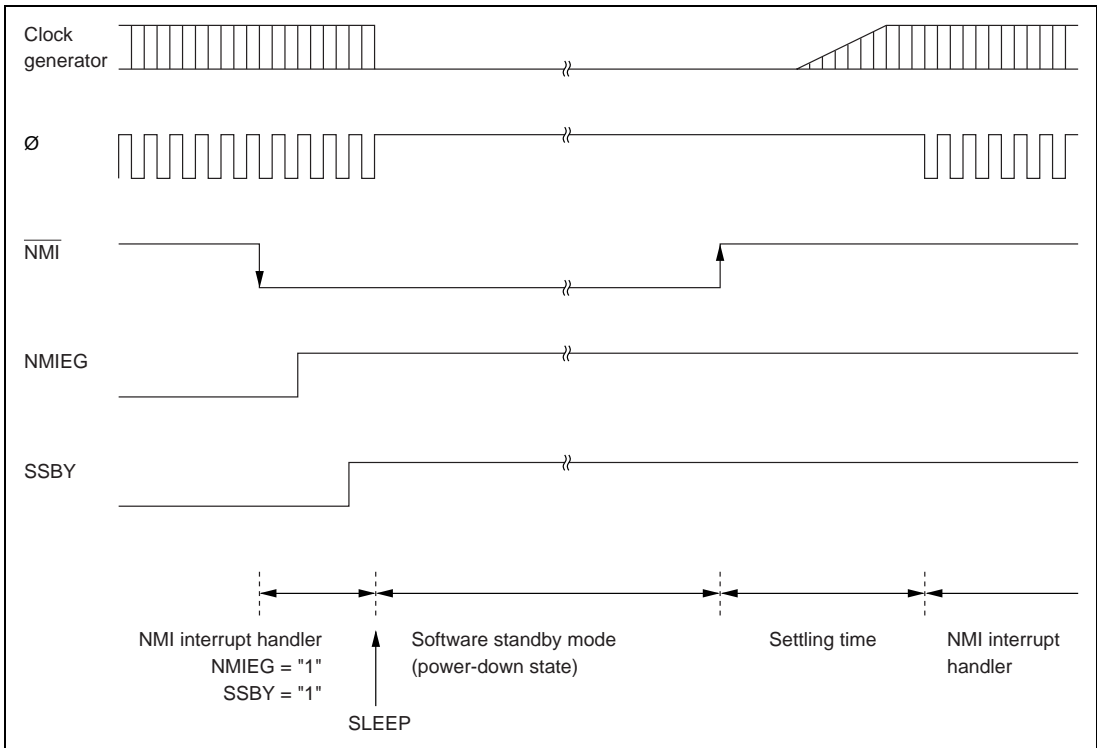

Figure 15.1 NMI Timing in Software Standby Mode

15.4.4 Application Note

1. The I/O ports retain their current states in the software standby mode. If a port is in the High output state, the current dissipation caused by the High output current is not reduced.
2. When software standby mode is entered under condition (a) or (b) below, current dissipation is higher ($I_{CC} = 100$ to $300 \mu\text{A}$) than normal in standby mode.
 - (a) In single-chip mode (mode 3): when software standby mode is entered by executing an instruction stored in on-chip ROM, after even one instruction not stored in on-chip ROM has been fetched (e.g. from on-chip RAM).
 - (b) In expanded mode with on-chip ROM enabled (mode 2): when software standby mode is entered by executing an instruction stored in on-chip ROM, after even one instruction not stored in on-chip ROM has been fetched (e.g. from external memory or on-chip RAM).

Note that the H8/300 CPU pre-fetches instructions. If an instruction stored in the last two bytes of on-chip ROM is executed, the contents of the next two bytes, not in on-chip ROM, will be fetched as the next instruction.

This problem does not occur in expanded mode when on-chip ROM is disabled (mode 1).

In hardware standby mode there is no additional current dissipation, regardless of the conditions when hardware standby mode is entered.

15.5 Hardware Standby Mode

15.5.1 Transition to Hardware Standby Mode

Regardless of its current state, the chip enters the hardware standby mode whenever the STBY pin goes Low.

The hardware standby mode reduces power consumption drastically by halting the CPU, stopping all the functions of the on-chip supporting modules, and placing I/O ports in the high-impedance state. The registers of the on-chip supporting modules are reset to their initial values. Only the on-chip RAM is held unchanged, provided the minimum necessary voltage supply is maintained (at least 2V).

- Notes:
1. The RAME bit in the system control register should be cleared to “0” before the STBY pin goes Low, to disable the on-chip RAM during the hardware standby mode.
 2. Do not change the inputs at the mode pins (MD1, MD0) during hardware standby mode. Be particularly careful not to let both mode pins go Low in hardware standby mode, since that places the chip in PROM mode and increases current dissipation.

15.5.2 Recovery from Hardware Standby Mode

Recovery from the hardware standby mode requires inputs at both the STBY and RES pins.

When the STBY pin goes High, the clock oscillator begins running. The RES pin should be Low at this time and should be held Low long enough for the clock to stabilize. When the RES pin changes from Low to High, the reset sequence is executed and the chip returns to the program execution state.

15.5.3 Timing Relationships

Figure 15.2 shows the timing relationships in the hardware standby mode.

In the sequence shown, first RES goes Low, then STBY goes Low, at which point the chip enters the hardware standby mode. To recover, first STBY goes High, then after the clock settling time, RES goes High.

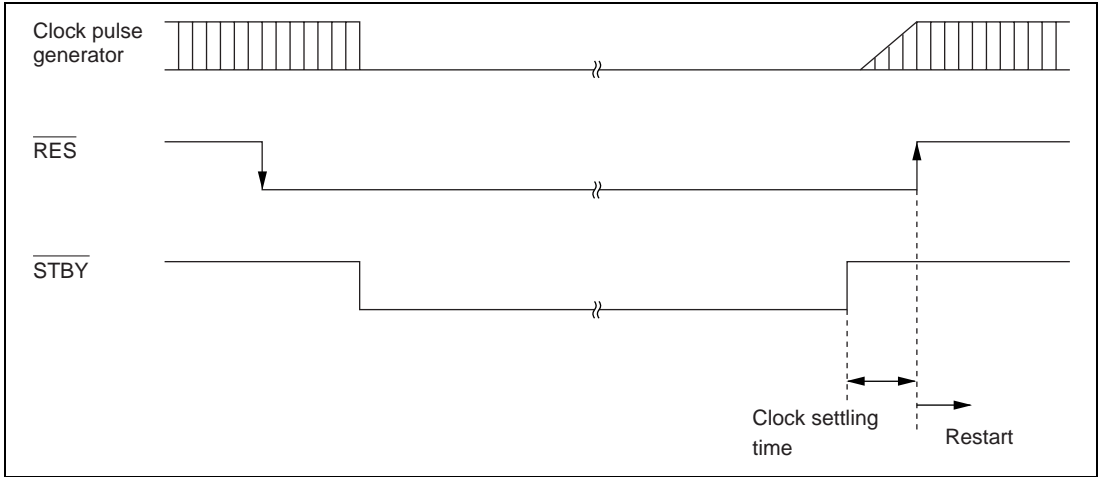

Figure 15.2 Hardware Standby Mode Timing

Section 16 Electrical Specifications

16.1 Absolute Maximum Ratings

Table 16.1 lists the absolute maximum ratings.

Table 16.1 Absolute Maximum Ratings

Item	Symbol	Rating	Unit	
Supply voltage	V_{CC}	-0.3 to +7.0	V	
Programming voltage	V_{PP}	-0.3 to +13.5	V	
Input voltage	Ports 1 – 6, 8, 9	V_{in}	-0.3 to $V_{CC} + 0.3$	V
	Port 7	V_{in}	-0.3 to $AV_{CC} + 0.3$	V
Analog supply voltage	AV_{CC}	-0.3 to +7.0	V	
Analog input voltage	V_{AN}	-0.3 to $AV_{CC} + 0.3$	V	
Operating temperature	T_{opr}	Regular specifications:	-20 to +75	°C
		Wide-range specifications:	-40 to +85	°C
Storage temperature	T_{stg}	-55 to +125	°C	

Note: Exceeding the absolute maximum ratings shown in table 16.1 can permanently destroy the chip.

16.2 Electrical Characteristics

16.2.1 DC Characteristics

Table 16.2 lists the DC characteristics of the 5V version. Table 16.3 lists the DC characteristics of the 3V version. Table 16.4 gives the allowable current output values of the 5V version.

Table 16.5 gives the allowable current output values of the 3V version.

Table 16.2 DC Characteristics (5V version)

Conditions: $V_{CC} = 5.0V \pm 10\%$, $AV_{CC} = 5.0V \pm 10\%*$, $V_{SS} = AV_{SS} = 0V$,
 $T_a = -20$ to $75^\circ C$ (regular specifications),
 $T_a = -40$ to $85^\circ C$ (wide-range specifications)

Item		Symbol	Min	Typ	Max	Unit	Measurement Conditions
Schmitt trigger input voltage (1)	P6 ₇ – P6 ₂ , P6 ₀ ,	V_T^-	1.0	—	—	V	
	P8 ₆ – P8 ₀ ,	V_T^+	—	—	$V_{CC} \times 0.7$	V	
	P9 ₇ , P9 ₄ – P9 ₀	$V_T^+ - V_T^-$	0.4	—	—	V	
Input High voltage (2)	\overline{RES} , \overline{STBY} , \overline{NMI} MD ₁ , MD ₀ EXTAL	V_{IH}	$V_{CC} - 0.7$	—	$V_{CC} + 0.3$	V	
	P7 ₇ – P7 ₀		2.0	—	$AV_{CC} + 0.3V$		
Input High voltage	Input pins other than (1) and (2)	V_{IH}	2.0	—	$V_{CC} + 0.3$	V	
Input Low voltage (3)	\overline{RES} , \overline{STBY} MD ₁ , MD ₀	V_{IL}	-0.3	—	0.5	V	
Input Low voltage	Input pins other than (1) and (3) above	V_{IL}	-0.3	—	0.8	V	
Output High voltage	All output pins	V_{OH}	$V_{CC} - 0.5$	—	—	V	$I_{OH} = -200\mu A$
			3.5	—	—	V	$I_{OH} = -1.0mA$
Output Low voltage	All output pins	V_{OL}	—	—	0.4	V	$I_{OL} = 1.6mA$
	Ports 1 and 2		—	—	1.0	V	$I_{OL} = 10.0mA$
Input leakage current	\overline{RES}	$ I_{in} $	—	—	10.0	μA	$V_{in} = 0.5V$ to $V_{CC} - 0.5V$
	\overline{STBY} , \overline{NMI} , MD ₁ , MD ₀		—	—	1.0	μA	
	P7 ₇ – P7 ₀		—	—	1.0	μA	$V_{in} = 0.5V$ to $AV_{CC} - 0.5V$
Leakage current in 3-state (off state)	Ports 1, 2, 3, 4, 5, 6, 8, 9	$ I_{TSI} $	—	—	1.0	μA	$V_{in} = 0.5V$ to $V_{CC} - 0.5V$
Input pull-up MOS current	Ports 1, 2, 3	-I _p	30	—	250	μA	$V_{in} = 0V$

Note: Connect AV_{CC} to the power supply (V_{CC}) even when the A/D and D/A converters are not used.

Table 16.2 DC Characteristics (5V version) (cont)

Conditions: $V_{CC} = AV_{CC} = 5.0V \pm 10\%$, $V_{SS} = AV_{SS} = 0V$,
 $T_a = -20$ to $75^\circ C$ (regular specifications),
 $T_a = -40$ to $85^\circ C$ (wide-range specifications)

Item		Symbol	Min	Typ	Max	Unit	Measurement Conditions
Input capacitance	\overline{RES} (V_{PP})	C_{in}	—	—	60	pF	$V_{in} = 0V$
	\overline{NMI}		—	—	30	pF	$f = 1MHz$
	All input pins except \overline{RES} and \overline{NMI}		—	—	15	pF	$T_a = 25^\circ C$
Current dissipation* ¹	Normal operation	I_{CC}	—	12	25	mA	$f = 6MHz$
			—	16	30	mA	$f = 8MHz$
			—	20	40	mA	$f = 10MHz$
	Sleep mode		—	8	15	mA	$f = 6MHz$
			—	10	20	mA	$f = 8MHz$
			—	12	25	mA	$f = 10MHz$
Standby modes* ²		—	0.01	5.0	μA		
Analog supply current	During A/D or D/A conversion	AI_{CC}	—	2.0	5.0	mA	
	Waiting		—	0.01	5.0	μA	
RAM standby voltage		V_{RAM}	2.0	—	—	V	

Notes: 1. Current dissipation values assume that $V_{IH\ min} = V_{CC} - 0.5V$, $V_{IL\ max} = 0.5V$, all output pins are in the no-load state, and all input pull-up transistors are off.

2. For these values it is assumed that $V_{RAM} \leq V_{CC} < 4.5V$ and $V_{IH\ min} = V_{CC} \times 0.9$, $V_{IL\ max} = 0.3V$.

Table 16.3 DC Characteristics (3V version)

Conditions: $V_{CC} = 3.0V \pm 10\%$, $AV_{CC} = 5.0V \pm 10\%^{*1}$, $V_{SS} = AV_{SS} = 0V$, $T_a = -20$ to $70^\circ C$

Item		Symbol	Min	Typ	Max	Unit	Measurement Conditions
Schmitt trigger input voltage* ² (1)	P6 ₇ – P6 ₂ , P6 ₀ ,	V_{T^-}	$V_{CC} \times 0.15$	—	—	V	
	P8 ₆ – P8 ₀ ,	V_{T^+}	—	—	$V_{CC} \times 0.7$	V	
	P9 ₇ , P9 ₄ – P9 ₀	$V_{T^+} - V_{T^-}$	0.2	—	—	V	
Input High voltage* ² (2)	\overline{RES} , \overline{STBY}	V_{IH}	$V_{CC} \times 0.9$	—	$V_{CC} + 0.3$	V	
	MD ₁ , MD ₀						
	\overline{EXTAL} , \overline{NMI}						
	P7 ₇ – P7 ₀		$V_{CC} \times 0.7$	—	$AV_{CC} + 0.3$	V	
	Input pins other than (1) and (2) above		$V_{CC} \times 0.7$	—	$V_{CC} + 0.3$	V	
Input Low voltage* ² (3)	\overline{RES} , \overline{STBY}	V_{IL}	-0.3	—	$V_{CC} \times 0.1$	V	
	MD ₁ , MD ₀						
	Input pins other than (1) and (3) above		-0.3	—	$V_{CC} \times 0.15$	V	
Output High voltage	All output pins	V_{OH}	$V_{CC} - 0.4$	—	—	V	$I_{OH} = -200\mu A$
			$V_{CC} - 0.9$	—	—	V	$I_{OH} = -1.0mA$
Output Low voltage	All output pins	V_{OL}	—	—	0.4	V	$I_{OL} = 0.8mA$
	Ports 1 and 2		—	—	0.4	V	$I_{OL} = 1.6mA$
Input leakage current	\overline{RES}	$ I_{in} $	—	—	10.0	μA	$V_{in} = 0.5$ to $V_{CC} - 0.5V$
	\overline{STBY} , \overline{NMI} , MD ₁ , MD ₀		—	—	1.0	μA	
	P7 ₇ – P7 ₀		—	—	1.0	μA	$V_{in} = 0.5$ to $AV_{CC} - 0.5V$
Leakage current in 3-state (off state)	Ports 1, 2, 3, 4, 5, 6, 8, 9	$ I_{TSI} $	—	—	1.0	μA	$V_{in} = 0.5$ to $V_{CC} - 0.5V$
Input pull-up MOS current	Ports 1, 2, 3	-I _p	3	—	120	μA	$V_{in} = 5.0V$

Notes: 1. Connect AV_{CC} to the power supply (V_{CC}) even when the A/D and D/A converters are not used.

2. In the range $3.3V < V_{CC} < 4.5V$, for the input levels of V_{IH} and V_{T^+} , apply the higher of the values given for the 5V and 3V versions. For V_{IL} and V_{T^-} , apply the lower of the values given for the 5V and 3V versions.

Table 16.3 DC Characteristics (3V version) (cont)

Conditions: $V_{CC} = 3.0V \pm 10\%$, $AV_{CC} = 5.0V \pm 10\%^{*1}$, $V_{SS} = AV_{SS} = 0V$, $T_a = -20$ to $70^\circ C$

Item		Symbol	Min	Typ	Max	Unit	Measurement Conditions	
Input capacitance	\overline{RES}	C_{in}	—	—	60	pF	$V_{in} = 0V$	
	\overline{NMI}		—	—	30	pF	$f = 1MHz$	
	All input pins except \overline{RES} and \overline{NMI}		—	—	15	pF	$T_a = 25^\circ C$	
Current dissipation ^{*1}	Normal operation	I_{CC}	—	6	—	mA	$f = 3MHz$	
	Sleep mode		—	10	20	mA	$f = 5MHz$	
			—	4	—	mA	$f = 3MHz$	
	Standby modes ^{*2}			—	6	12	mA	$f = 5MHz$
				—	0.01	5.0	μA	
Analog supply current	During A/D or D/A conversion	AI_{CC}	—	2.0	5.0	mA		
	Waiting		—	0.01	5.0	μA		
RAM backup voltage (in standby modes)		V_{RAM}	2.0	—	—	V		

Notes: 1. Current dissipation values assume that $V_{IH\ min} = V_{CC} - 0.5V$, $V_{IL\ max} = 0.5V$, all output pins are in the no-load state, and all input pull-up transistors are off.

2. For these values it is assumed that $V_{RAM} \leq V_{CC} < 2.7V$ and $V_{IH\ min} = V_{CC} \times 0.9$, $V_{IL\ max} = 0.3V$.

Table 16.4 Allowable Output Current Values (5V version)

Conditions: $V_{CC} = AV_{CC} = 5.0V \pm 10\%$, $V_{SS} = AV_{SS} = 0V$,
 $T_a = -20$ to $75^\circ C$ (regular specifications),
 $T_a = -40$ to $85^\circ C$ (wide-range specifications)

Item		Symbol	Min	Typ	Max	Unit
Allowable output Low current (per pin)	Ports 1 and 2	I_{OL}	—	—	10	mA
	Other output pins		—	—	2.0	mA
Allowable output Low current (total)	Ports 1 and 2, total	ΣI_{OL}	—	—	80	mA
	Total of all output		—	—	120	mA
Allowable output High current (per pin)	All output pins	$-I_{OH}$	—	—	2.0	mA
Allowable output High current (total)	Total of all output	$\Sigma -I_{OH}$	—	—	40	mA

Table 16.5 Allowable Output Current Values (3V version)

Conditions: $V_{CC} = 3.0V \pm 10\%$, $AV_{CC} = 5.0V \pm 10\%$, $V_{SS} = AV_{SS} = 0V$, $T_a = -20$ to $75^\circ C$

Item		Symbol	Min	Typ	Max	Unit
Allowable output Low current (per pin)	Ports 1 and 2	I_{OL}	—	—	2	mA
	Other output pins		—	—	1	mA
Allowable output Low current (total)	Ports 1 and 2, total	ΣI_{OL}	—	—	40	mA
	Total of all output		—	—	60	mA
Allowable output High current (per pin)	All output pins	$-I_{OH}$	—	—	2	mA
Allowable output High current (total)	Total of all output	$\Sigma -I_{OH}$	—	—	30	mA

Note: To avoid degrading the reliability of the chip, be careful not to exceed the output current values in tables 16.4 and 16.5. In particular, when driving a Darlington transistor pair or LED directly, be sure to insert a current-limiting resistor in the output path. See figures 16.1 and 16.2.

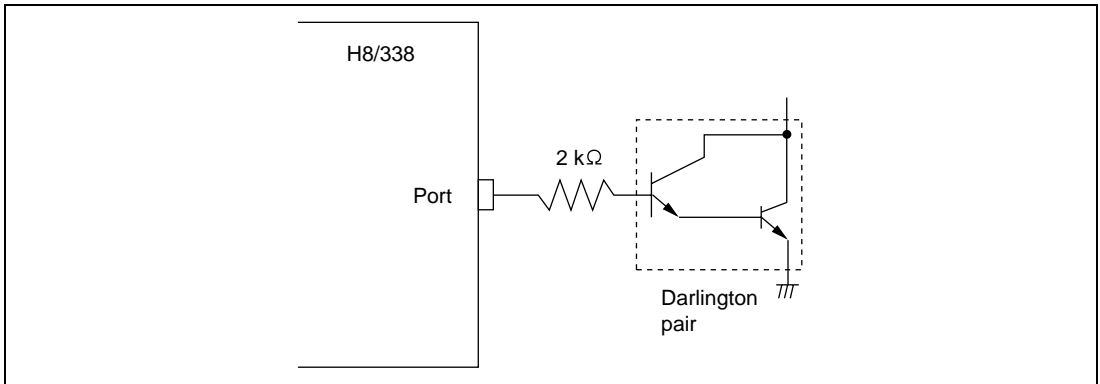

Figure 16.1 Example of Circuit for Driving a Darlington Pair (5V Version)

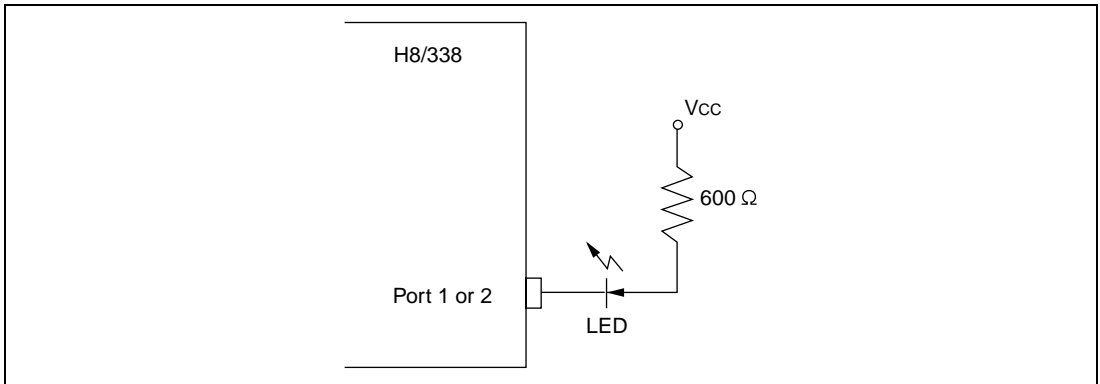

Figure 16.2 Example of Circuit for Driving an LED (5V Version)

16.2.2 AC Characteristics

The AC characteristics are listed in three tables. Bus timing parameters are given in table 16.6, control signal timing parameters in table 16.7, and timing parameters of the on-chip supporting modules in table 16.8.

Table 16.6 Bus Timing

Condition A: $V_{CC} = 5.0V \pm 10\%$, $V_{SS} = 0V$, $\phi = 0.5MHz$ to maximum operating frequency,
 $T_a = -20$ to $75^\circ C$ (regular specifications),
 $T_a = -40$ to $85^\circ C$ (wide-range specifications)

Condition B: $V_{CC} = 3.0V \pm 10\%$, $V_{SS} = 0V$, $\phi = 0.5MHz$ to maximum operating frequency,
 $T_a = -20$ to $75^\circ C$

Item	Symbol	Condition B		Condition A				Unit	Measurement Conditions		
		5MHz		6MHz		8MHz				10MHz	
		Min	Max	Min	Max	Min	Max			Min	Max
Clock cycle time	t_{cyc}	200	2000	166.7	2000	125	2000	100	2000	ns	Fig. 16.4
Clock pulse width Low	t_{CL}	70	—	65	—	45	—	35	—	ns	Fig. 16.4
Clock pulse width High	t_{CH}	70	—	65	—	45	—	35	—	ns	Fig. 16.4
Clock rise time	t_{Cr}	—	25	—	15	—	15	—	15	ns	Fig. 16.4
Clock fall time	t_{Cf}	—	25	—	15	—	15	—	15	ns	Fig. 16.4
Address delay time	t_{AD}	—	90	—	70	—	60	—	50	ns	Fig. 16.4
Address hold time	t_{AH}	30	—	30	—	25	—	20	—	ns	Fig. 16.4
Address strobe delay time	t_{ASD}	—	80	—	70	—	60	—	40	ns	Fig. 16.4
Write strobe delay time	t_{WSD}	—	80	—	70	—	60	—	50	ns	Fig. 16.4
Strobe delay time	t_{SD}	—	90	—	70	—	60	—	50	ns	Fig. 16.4
Write strobe pulse width*	t_{WSW}	200	—	200	—	150	—	120	—	ns	Fig. 16.4
Address setup time 1*	t_{AS1}	25	—	25	—	20	—	15	—	ns	Fig. 16.4
Address setup time 2*	t_{AS2}	105	—	105	—	80	—	65	—	ns	Fig. 16.4
Read data setup time	t_{RDS}	90	—	70	—	50	—	35	—	ns	Fig. 16.4
Read data hold time*	t_{RDH}	0	—	0	—	0	—	0	—	ns	Fig. 16.4
Read data access time*	t_{ACC}	—	300	—	270	—	210	—	170	ns	Fig. 16.4
Write data delay time	t_{WDD}	—	125	—	85	—	75	—	75	ns	Fig. 16.4
Write data setup time	t_{WDS}	10	—	20	—	10	—	5	—	ns	Fig. 16.4
Write data hold time	t_{WDH}	30	—	30	—	25	—	20	—	ns	Fig. 16.4
Wait setup time	t_{WTS}	60	—	40	—	40	—	40	—	ns	Fig. 16.5
Wait hold time	t_{WTH}	20	—	10	—	10	—	10	—	ns	Fig. 16.5

Note: Values at maximum operating frequency

Table 16.7 Control Signal Timing

Condition A: $V_{CC} = 5.0V \pm 10\%$, $V_{SS} = 0V$, $\phi = 0.5\text{MHz}$ to maximum operating frequency,
 $T_a = -20$ to 75°C (regular specifications),
 $T_a = -40$ to 85°C (wide-range specifications)

Condition B: $V_{CC} = 3.0V \pm 10\%$, $V_{SS} = 0V$, $\phi = 0.5\text{MHz}$ to maximum operating frequency,
 $T_a = -20$ to 75°C

Item	Symbol	Condition B		Condition A				Unit	Measurement Conditions		
		5MHz		6MHz		8MHz				10MHz	
		Min	Max	Min	Max	Min	Max			Min	Max
RES setup time	t_{RESS}	300	—	200	—	200	—	200	—	ns	Fig. 16.6
RES pulse width	t_{RESW}	10	—	10	—	10	—	10	—	tcyc	Fig. 16.6
NMI setup time ($\overline{\text{NMI}}$, $\overline{\text{IRQ}}_0$ to $\overline{\text{IRQ}}_7$)	t_{NMIS}	300	—	150	—	150	—	150	—	ns	Fig. 16.7
NMI hold time ($\overline{\text{NMI}}$, $\overline{\text{IRQ}}_0$ to $\overline{\text{IRQ}}_7$)	t_{NMIH}	10	—	10	—	10	—	10	—	ns	Fig. 16.7
Interrupt pulse width for recovery from software standby mode ($\overline{\text{NMI}}$, $\overline{\text{IRQ}}_0$ to $\overline{\text{IRQ}}_2$)	t_{NMIW}	300	—	200	—	200	—	200	—	ns	Fig. 16.7
Crystal oscillator settling time (reset)	t_{OSC1}	20	—	20	—	20	—	20	—	ms	Fig. 16.8
Crystal oscillator settling time (software standby)	t_{OSC2}	10	—	10	—	10	—	10	—	ms	Fig. 16.9

Table 16.8 Timing Conditions of On-Chip Supporting Modules

Condition A: $V_{CC} = 5.0V \pm 10\%$, $V_{SS} = 0V$, $\phi = 0.5MHz$ to maximum operating frequency,
 $T_a = -20$ to $75^\circ C$ (regular specifications),
 $T_a = -40$ to $85^\circ C$ (wide-range specifications)

Condition B: $V_{CC} = 3.0V \pm 10\%$, $V_{SS} = 0V$, $\phi = 0.5MHz$ to maximum operating frequency,
 $T_a = -20$ to $75^\circ C$

Item	Symbol	Condition B		Condition A				Unit	Measurement Conditions				
		5MHz		6MHz		8MHz				10MHz			
		Min	Max	Min	Max	Min	Max			Min	Max		
FRT	Timer output delay time	t_{FOD}	—	150	—	100	—	100	—	100	ns	Fig. 16.10	
	Timer input setup time	t_{FTIS}	80	—	50	—	50	—	50	—	ns	Fig. 16.10	
	Timer clock input setup time	t_{FTCS}	80	—	50	—	50	—	50	—	ns	Fig. 16.11	
	Timer clock pulse width	t_{FTCWH} t_{FTCWL}	1.5	—	1.5	—	1.5	—	1.5	—	tcyc	Fig. 16.11	
TMR	Timer output delay time	t_{TOD}	—	150	—	100	—	100	—	100	ns	Fig. 16.12	
	Timer reset input setup time	t_{TMRS}	80	—	50	—	50	—	50	—	ns	Fig. 16.14	
	Timer clock input setup time	t_{TMCS}	80	—	50	—	50	—	50	—	ns	Fig. 16.13	
	Timer clock pulse width (single edge)	t_{TMCWH}	1.5	—	1.5	—	1.5	—	1.5	—	tcyc	Fig. 16.13	
	Timer clock pulse width (both edges)	t_{TMCWL}	2.5	—	2.5	—	2.5	—	2.5	—	tcyc	Fig. 16.13	
PWM	Timer output delay time	t_{PWOD}	—	150	—	100	—	100	—	100	ns	Fig. 16.15	
SCI	Input clock cycle	(Async)	t_{scyc}	4	—	4	—	4	—	4	—	tcyc	Fig. 16.16
		(Sync)	t_{scyc}	6	—	6	—	6	—	6	—	tcyc	Fig. 16.16
	Transmit data delay time (Sync)	t_{TXD}	—	200	—	100	—	100	—	100	ns	Fig. 16.16	
	Receive data setup time (Sync)	t_{RXS}	150	—	100	—	100	—	100	—	ns	Fig. 16.16	
	Receive data hold time (Sync)	t_{RXH}	150	—	100	—	100	—	100	—	ns	Fig. 16.16	
	Input clock pulse width	t_{SCKW}	0.4	0.6	0.4	0.6	0.4	0.6	0.4	0.6	tscyc	Fig. 16.17	

Table 16.8 Timing Conditions of On-Chip Supporting Modules (cont)

Condition A: $V_{CC} = 5.0V \pm 10\%$, $V_{SS} = 0V$, $\phi = 0.5MHz$ to maximum operating frequency,
 $T_a = -20$ to $75^\circ C$ (regular specifications),
 $T_a = -40$ to $85^\circ C$ (wide-range specifications)

Condition B: $V_{CC} = 3.0V \pm 10\%$, $V_{SS} = 0V$, $\phi = 0.5MHz$ to maximum operating frequency,
 $T_a = -20$ to $75^\circ C$

Item	Symbol	Condition B		Condition A				Unit	Measurement Conditions			
		5MHz		6MHz		8MHz				10MHz		
		Min	Max	Min	Max	Min	Max			Min	Max	
Ports	Output data delay time	t_{PWD}	—	150	—	100	—	100	—	100	ns	Fig. 16.18
	Input data setup time	t_{PRS}	80	—	50	—	50	—	50	—	ns	Fig. 16.18
	Input data hold time	t_{PRH}	80	—	50	—	50	—	50	—	ns	Fig. 16.18

• **Measurement Conditions for AC Characteristics**

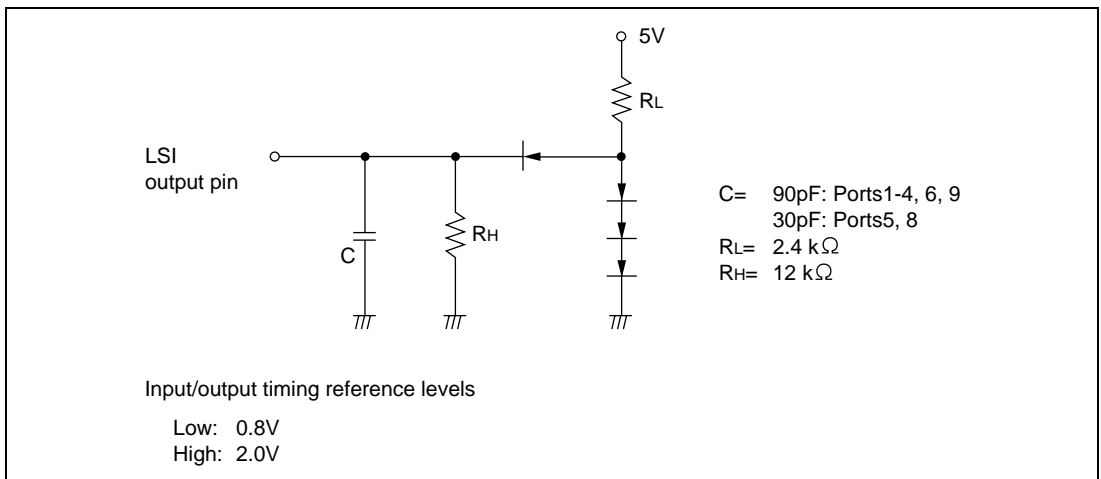

Figure 16.3 Output Load Circuit

16.2.3 A/D Converter Characteristics

Table 16.9 lists the characteristics of the on-chip A/D converter.

Table 16.9 A/D Converter Characteristics

Condition A: $V_{CC} = 5.0V \pm 10\%$, $AV_{CC} = 5.0V \pm 10\%$, $V_{SS} = AV_{SS} = 0V$, $\phi = 0.5MHz$ to maximum

operating frequency, $T_a = -20$ to $75^\circ C$ (regular specifications),
 $T_a = -40$ to $85^\circ C$ (wide-range specifications)

Condition B: $V_{CC} = 3.0V \pm 10\%$, $AV_{CC} = 5.0V \pm 10\%$, $V_{SS} = AV_{SS} = 0V$, $\phi = 0.5MHz$ to maximum operating frequency, $T_a = -20$ to $75^\circ C$

Item	Condition B						Condition A						Unit
	5MHz			6MHz			8MHz			10MHz			
	Min	Typ	Max	Min	Typ	Max	Min	Typ	Max	Min	Typ	Max	
Resolution	8	8	8	8	8	8	8	8	8	8	8	8	Bits
Conversion time (single mode)*	—	—	24.4	—	—	20.4	—	—	15.25	—	—	12.2	μs
Analog input capacitance	—	—	20	—	—	20	—	—	20	—	—	20	pF
Allowable signal source impedance	—	—	10	—	—	10	—	—	10	—	—	10	k Ω
Nonlinearity error	—	—	± 1	—	—	± 1	—	—	± 1	—	—	± 1	LSB
Offset error	—	—	± 1	—	—	± 1	—	—	± 1	—	—	± 1	LSB
Full-scale error	—	—	± 1	—	—	± 1	—	—	± 1	—	—	± 1	LSB
Quantizing error	—	—	± 0.5	—	—	± 0.5	—	—	± 0.5	—	—	± 0.5	LSB
Absolute accuracy	—	—	± 1.5	—	—	± 1.5	—	—	± 1.5	—	—	± 1.5	LSB

Note: Values at maximum operating frequency

16.2.4 D/A Converter Characteristics

Table 16.10 lists the characteristics of the on-chip D/A converter.

Table 16.10 D/A Converter Characteristics

Condition A: $V_{CC} = 5.0V \pm 10\%$, $AV_{CC} = 5.0V \pm 10\%$, $V_{SS} = AV_{SS} = 0V$, $\phi = 0.5MHz$ to maximum

operating frequency, $T_a = -20$ to $75^\circ C$ (regular specifications),
 $T_a = -40$ to $85^\circ C$ (wide-range specifications)

Condition B: $V_{CC} = 3.0V \pm 10\%$, $AV_{CC} = 5.0V \pm 10\%$, $V_{SS} = AV_{SS} = 0V$, $\phi = 0.5MHz$ to maximum

operating frequency, $T_a = -20$ to $75^\circ C$

Item	Condition B			Condition A									Unit	Measurement Conditions
	5MHz			6MHz			8MHz			10MHz				
	Min	Typ	Max	Min	Typ	Max	Min	Typ	Max	Min	Typ	Max		
Resolution	8	8	8	8	8	8	8	8	8	8	8	8	Bits	
Conversion time	—	—	10.0	—	—	10.0	—	—	10.0	—	—	10.0	μs	30pF load capacitance
Absolute accuracy	—	± 1	± 1.5	—	± 1	± 1.5	—	± 1	± 1.5	—	± 1	± 1.5	LSB	2M Ω load resistance
	—	—	± 1	—	—	± 1	—	—	± 1	—	—	± 1	LSB	4M Ω load resistance

16.3 MCU Operational Timing

This section provides the following timing charts:

16.3.1 Bus Timing	Figures 16.4 to 16.5
16.3.2 Control Signal Timing	Figures 16.6 to 16.9
16.3.3 16-Bit Free-Running Timer Timing	Figures 16.10 to 16.11
16.3.4 8-Bit Timer Timing	Figures 16.12 to 16.14
16.3.5 PWM Timer Timing	Figure 16.15
16.3.6 SCI Timing	Figures 16.16 to 16.17
16.3.7 I/O Port Timing	Figure 16.18

16.3.1 Bus Timing

(1) Basic Bus Cycle (without Wait States) in Expanded Modes

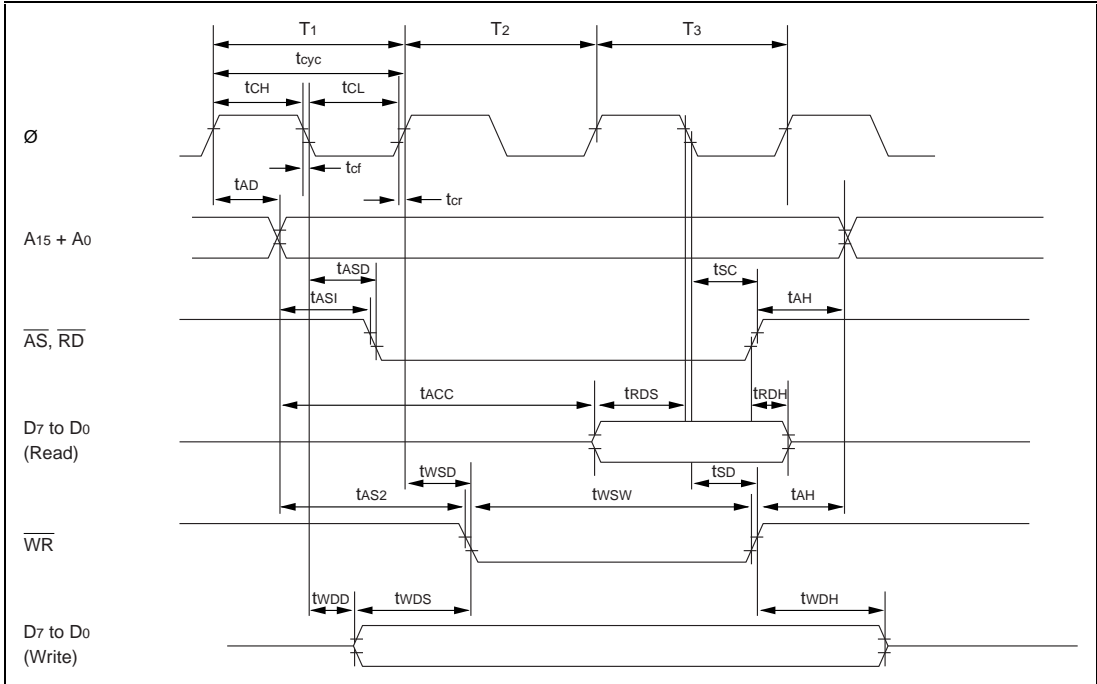

Figure 16.4 Basic Bus Cycle (without wait states) in Expanded Modes

(2) Basic Bus Cycle (with 1 Wait State) in Expanded Modes

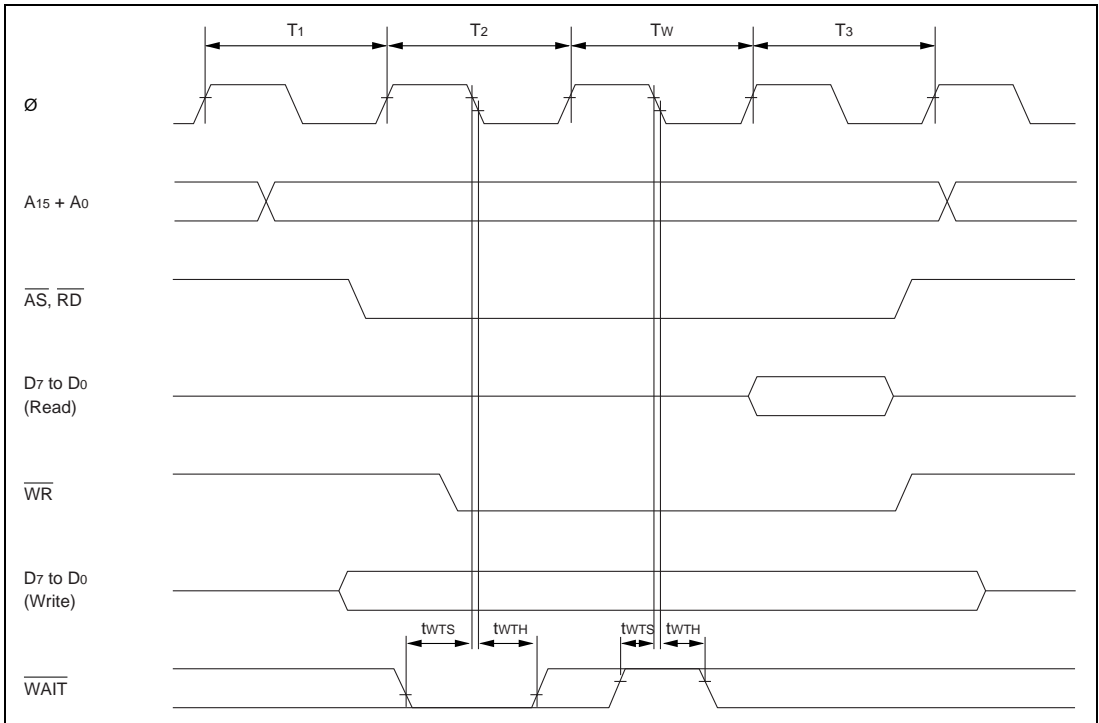

Figure 16.5 Basic Bus Cycle (with 1 wait state) in Expanded Modes

16.3.2 Control Signal Timing

(1) Reset Input Timing

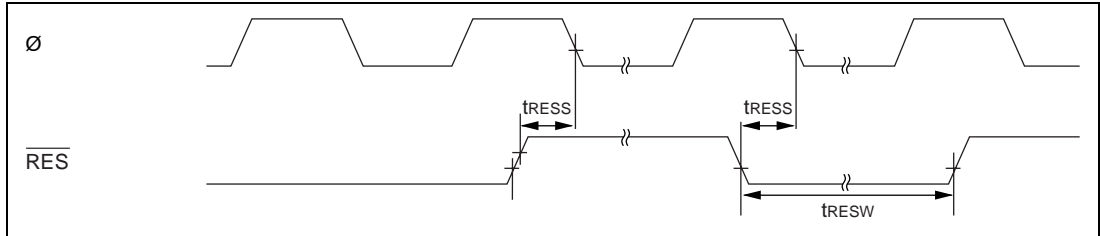

Figure 16.6 Reset Input Timing

(2) Interrupt Input Timing

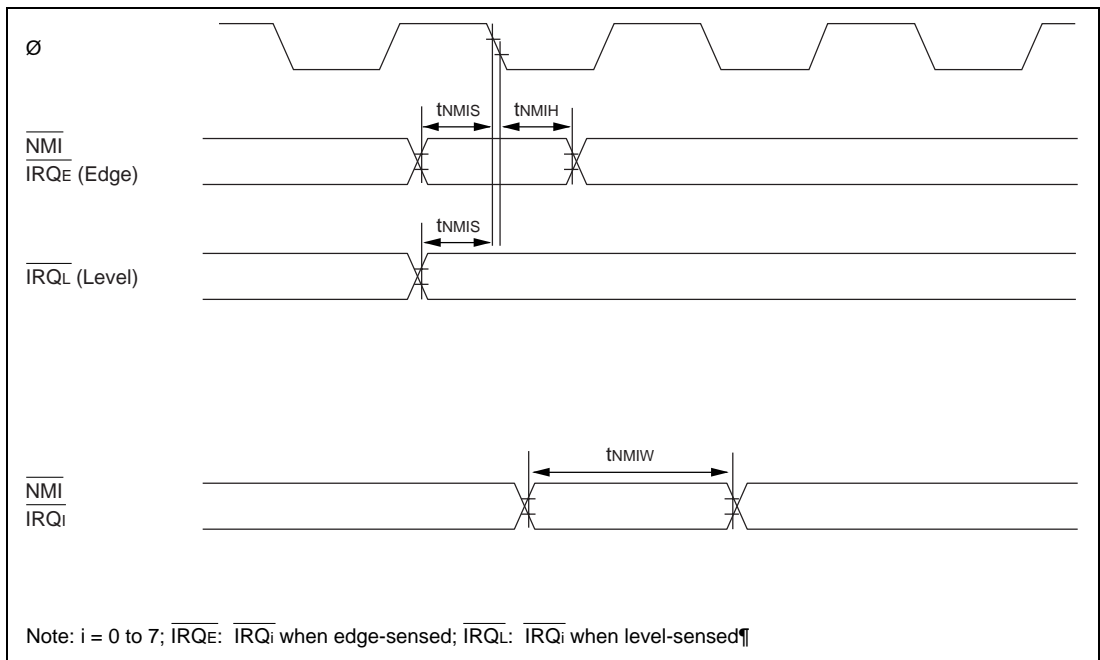

Figure 16.7 Interrupt Input Timing

(3) Clock Settling Timing

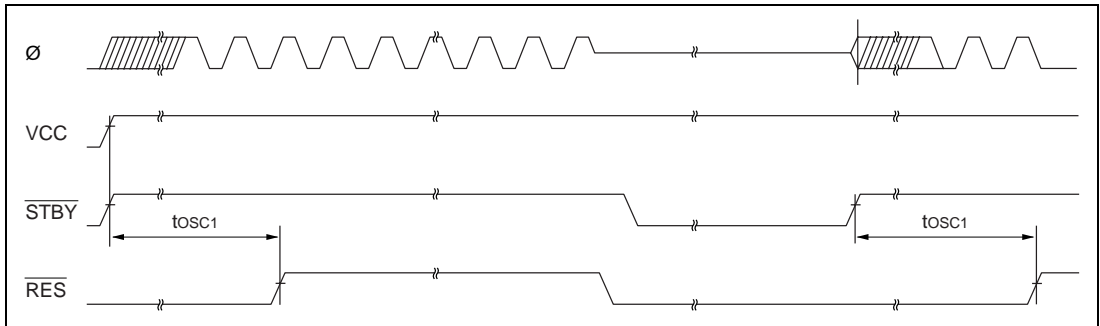

Figure 16.8 Clock Settling Timing

(4) Clock Settling Timing for Recovery from Software Standby Mode

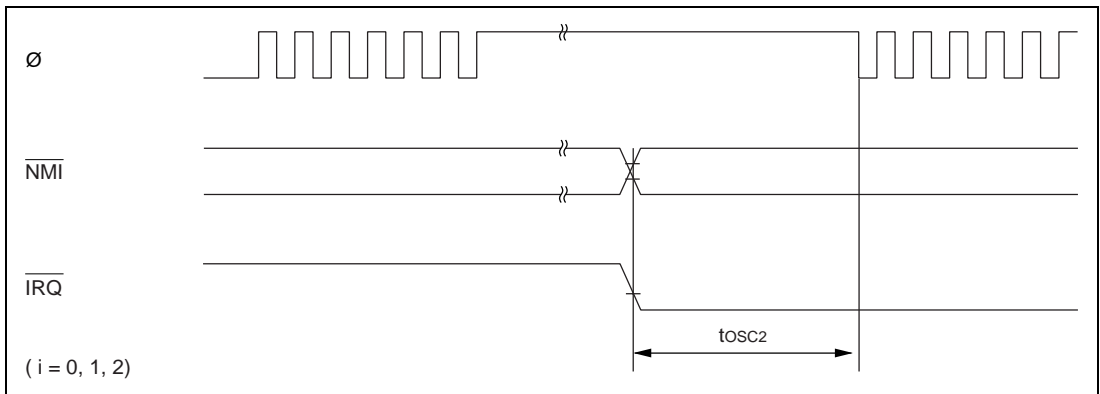

Figure 16.9 Clock Settling Timing for Recovery from Software Standby Mode

16.3.3 16-Bit Free-Running Timer Timing

(1) Free-Running Timer Input/Output Timing

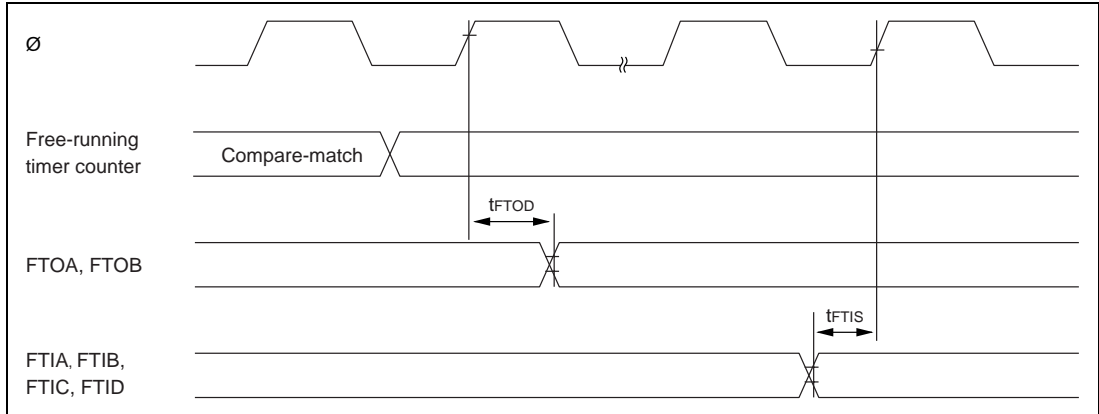

Figure 16.10 Free-Running Timer Input/Output Timing

(2) External Clock Input Timing for Free-Running Timer

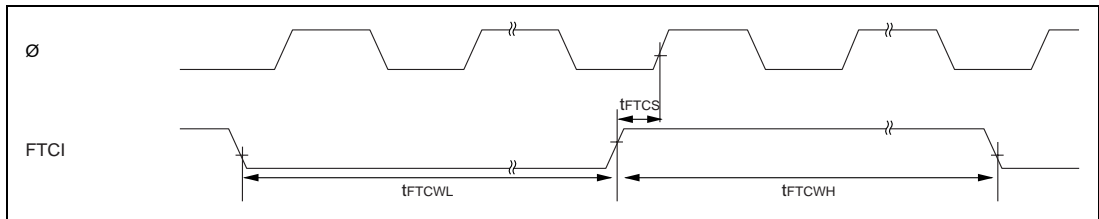

Figure 16.11 External Clock Input Timing for Free-Running Timer

16.3.4 8-Bit Timer Timing

(1) 8-Bit Timer Output Timing

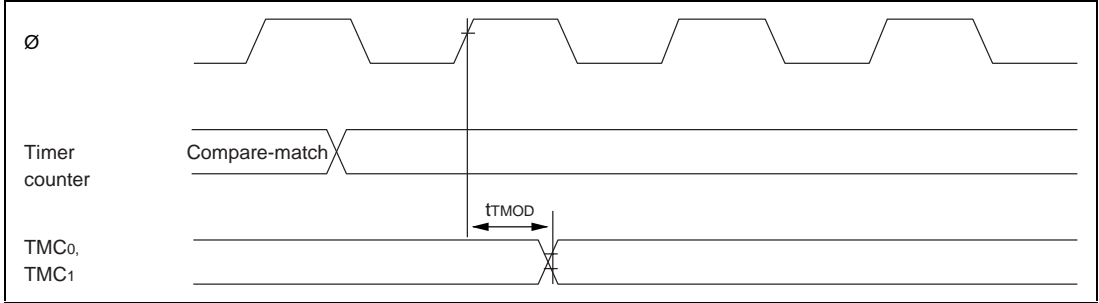

Figure 16.12 8-Bit Timer Output Timing

(2) 8-Bit Timer Clock Input Timing

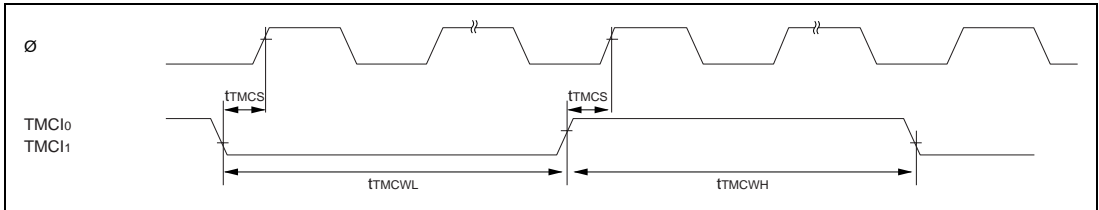

Figure 16.13 8-Bit Timer Clock Input Timing

(3) 8-Bit Timer Reset Input Timing

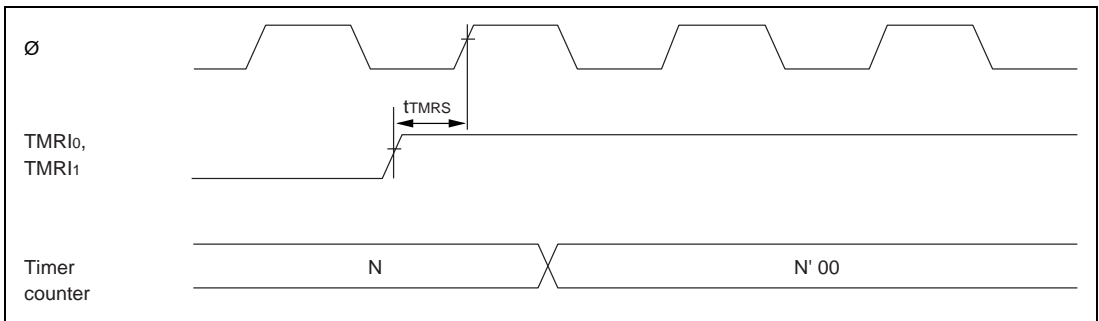

Figure 16.14 8-Bit Timer Reset Input Timing

16.3.5 Pulse Width Modulation Timer Timing

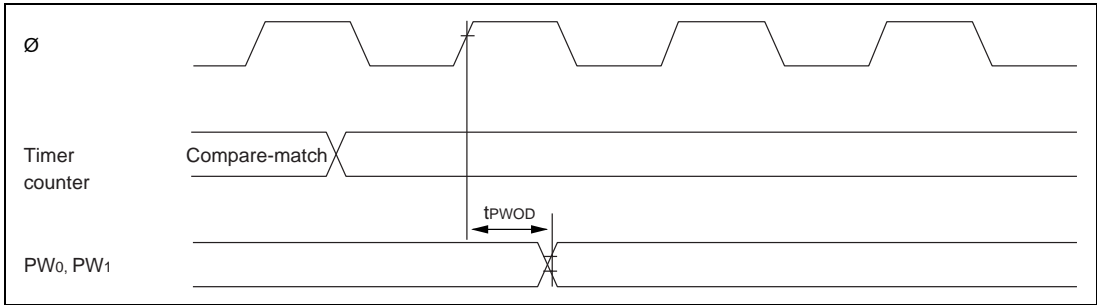

Figure 16.15 PWM Timer Output Timing

16.3.6 Serial Communication Interface Timing

(1) SCI Input/Output Timing

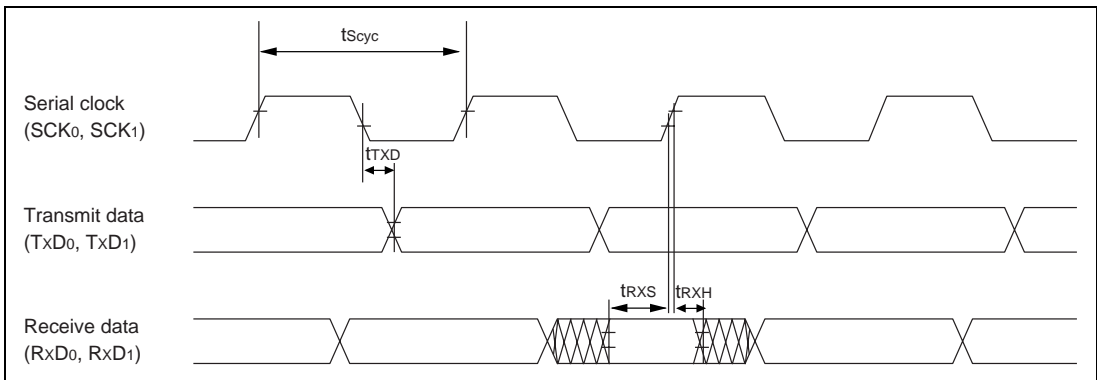

Figure 16.16 SCI Input/Output Timing (Synchronous mode)

(2) SCI Input Clock Timing

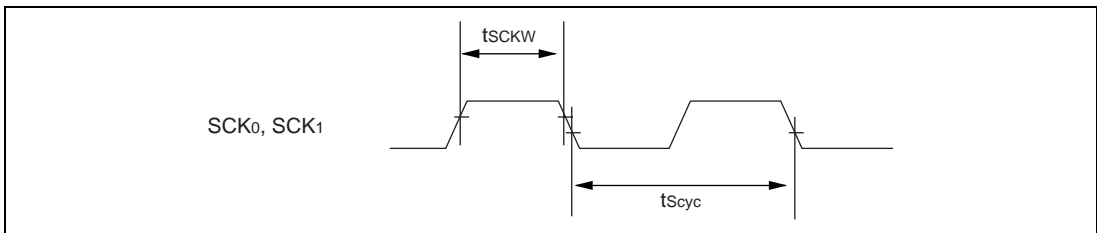

Figure 16.17 SCI Input Clock Timing

16.3.7 I/O Port Timing

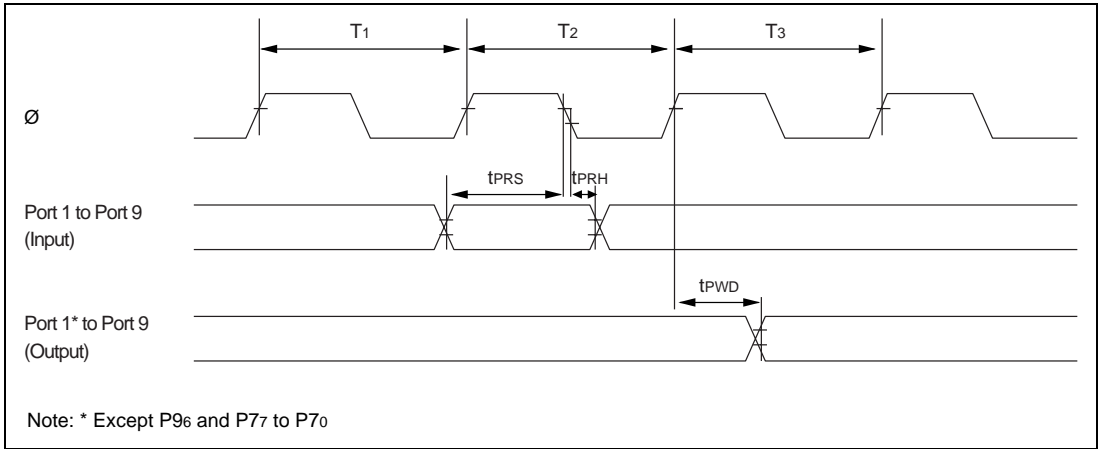

Figure 16.18 I/O Port Input/Output Timing

Appendix A CPU Instruction Set

A.1 Instruction Set List

Operation Notation

Rd8/16	General register (destination) (8 or 16 bits)
Rs8/16	General register (source) (8 or 16 bits)
Rn8/16	General register (8 or 16 bits)
CCR	Condition code register
N	N (negative) flag in CCR
Z	Z (zero) flag in CCR
V	V (overflow) flag in CCR
C	C (carry) flag in CCR
PC	Program counter
SP	Stack pointer
#xx:3/8/16	Immediate data (3, 8, or 16 bits)
d:8/16	Displacement (8 or 16 bits)
@aa:8/16	Absolute address (8 or 16 bits)
+	Addition
-	Subtraction
×	Multiplication
÷	Division
^	AND logical
∨	OR logical
⊕	Exclusive OR logical
→	Move
—	Not

Condition Code Notation

↕	Modified according to the instruction result
*	Undetermined (unpredictable)
0	Always cleared to "0"
—	Not affected by the instruction result

Table A.1 Instruction Set (cont)

Mnemonic	Operand Size	Operation	Addressing Mode/ Instruction Length								Condition Code						No. of States	
			#xx: 8/16	Rn	@Rn	@(d:16, Rn)	@-Rn/@Rn+	@aa: 8/16	@(d:8, PC)	@@aa	Implied	I	H	N	Z	V		C
MOVFP@aa:16, Rd																		
MOVTPE Rs, @aa:16																		
EEPMOV	—	if R4L≠0 then Repeat @R5 → @R6 R5+1 → R5 R6+1 → R6 R4L-1 → R4L Until R4L=0 else next;								4			↑	↑	—	—	(4)	
ADD.B #xx:8, Rd	B	Rd8+#xx:8 → Rd8	2									—	↑	↑	↑	↑	↑	2
ADD.B Rs, Rd	B	Rd8+Rs8 → Rd8		2								—	↑	↑	↑	↑	↑	2
ADD.W Rs, Rd	W	Rd16+Rs16 → Rd16		2								—	(1)	↑	↑	↑	↑	2
ADDX.B #xx:8, Rd	B	Rd8+#xx:8 +C → Rd8	2									—	↑	↑	(2)	↑	↑	2
ADDX.B Rs, Rd	B	Rd8+Rs8 +C → Rd8		2								—	↑	↑	(2)	↑	↑	2
ADDS.W #1, Rd	W	Rd16+1 → Rd16		2								—	—	—	—	—	—	2
ADDS.W #2, Rd	W	Rd16+2 → Rd16		2								—	—	—	—	—	—	2
INC.B Rd	B	Rd8+1 → Rd8		2								—	—	↑	↑	↑	—	2
DAA.B Rd	B	Rd8 decimal adjust → Rd8		2								—	*	↑	↑	*	(3)	2
SUB.B Rs, Rd	B	Rd8-Rs8 → Rd8		2								—	↑	↑	↑	↑	↑	2
SUB.W Rs, Rd	W	Rd16-Rs16 → Rd16		2								—	(1)	↑	↑	↑	↑	2
SUBX.B #xx:8, Rd	B	Rd8-#xx:8 -C → Rd8	2									—	↑	↑	(2)	↑	↑	2
SUBX.B Rs, Rd	B	Rd8-Rs8 -C → Rd8		2								—	↑	↑	(2)	↑	↑	2
SUBS.W #1, Rd	W	Rd16-1 → Rd16		2								—	—	—	—	—	—	2
SUBS.W #2, Rd	W	Rd16-2 → Rd16		2								—	—	—	—	—	—	2
DEC.B Rd	B	Rd8-1 → Rd8		2								—	—	↑	↑	↑	—	2
DAS.B Rd	B	Rd8 decimal adjust → Rd8		2								—	*	↑	↑	*	—	2
NEG.B Rd	B	0-Rd → Rd		2								—	↑	↑	↑	↑	↑	2
CMP.B #xx:8, Rd	B	Rd8-#xx:8	2									—	↑	↑	↑	↑	↑	2
CMP.B Rs, Rd	B	Rd8-Rs8		2								—	↑	↑	↑	↑	↑	2
CMP.W Rs, Rd	W	Rd16-Rs16		2								—	(1)	↑	↑	↑	↑	2
MULXU.B Rs, Rd	B	Rd8 × Rs8 → Rd16		2								—	—	—	—	—	—	14

Table A.1 Instruction Set (cont)





Mnemonic	Operand Size	Operation	Addressing Mode/ Instruction Length								Condition Code						No. of States			
			#xx: 8/16	Rn	@Rn	@(d:16, Rn)	@-Rn/@Rn+	@aa: 8/16	@(d:8, PC)	@@aa	Implied	I	H	N	Z	V		C		
DIVXU.B Rs, Rd	B	Rd16÷Rs8 → Rd16 (RdH: remainder, RdL: quotient)	2											—	—	(6)	7)	—	—	14
AND.B #xx:8, Rd	B	Rd8∧#xx:8 → Rd8	2											—	—	↑	↑	0	—	2
AND.B Rs, Rd	B	Rd8∧Rs8 → Rd8	2											—	—	↑	↑	0	—	2
OR.B #xx:8, Rd	B	Rd8#xx:8 → Rd8	2											—	—	↑	↑	0	—	2
OR.B Rs, Rd	B	Rd8#Rs8 → Rd8	2											—	—	↑	↑	0	—	2
XOR.B #xx:8, Rd	B	Rd8⊕#xx:8 → Rd8	2											—	—	↑	↑	0	—	2
XOR.B Rs, Rd	B	Rd8⊕Rs8 → Rd8	2											—	—	↑	↑	0	—	2
NOT.B Rd	B	$\overline{Rd} \rightarrow Rd$	2											—	—	↑	↑	0	—	2
SHAL.B Rd	B		2											—	—	↑	↑	↑	↑	2
SHAR.B Rd	B		2											—	—	↑	↑	0	↑	2
SHLL.B Rd	B		2											—	—	↑	↑	0	↑	2
SHLR.B Rd	B		2											—	—	↑	↑	0	↑	2
ROTXL.B Rd	B		2											—	—	↑	↑	0	↑	2
ROTXR.B Rd	B		2											—	—	↑	↑	0	↑	2
ROTL.B Rd	B		2											—	—	↑	↑	0	↑	2
ROTR.B Rd	B		2											—	—	↑	↑	0	↑	2

Table A.1 Instruction Set (cont)

Mnemonic	Operand Size	Operation	Addressing Mode/ Instruction Length							Condition Code						No. of States	
			#xx: 8/16	Rn	@Rn	@(d:16, Rn)	@-Rn/@Rn+	@aa: 8/16	@(d:8, PC)	@@aa	Implied	I	H	N	Z		V
BSET #xx:3, Rd	B	(#xx:3 of Rd8) ← 1		2													2
BSET #xx:3, @Rd	B	(#xx:3 of @Rd16) ← 1			4												8
BSET #xx:3, @aa:8	B	(#xx:3 of @aa:8) ← 1						4									8
BSET Rn, Rd	B	(Rn8 of Rd8) ← 1		2													2
BSET Rn, @Rd	B	(Rn8 of @Rd16) ← 1			4												8
BSET Rn, @aa:8	B	(Rn8 of @aa:8) ← 1						4									8
BCLR #xx:3, Rd	B	(#xx:3 of Rd8) ← 0		2													2
BCLR #xx:3, @Rd	B	(#xx:3 of @Rd16) ← 0			4												8
BCLR #xx:3, @aa:8	B	(#xx:3 of @aa:8) ← 0						4									8
BCLR Rn, Rd	B	(Rn8 of Rd8) ← 0		2													2
BCLR Rn, @Rd	B	(Rn8 of @Rd16) ← 0			4												8
BCLR Rn, @aa:8	B	(Rn8 of @aa:8) ← 0						4									8
BNOT #xx:3, Rd	B	(#xx:3 of Rd8) ← (#xx:3 of Rd8)		2													2
BNOT #xx:3, @Rd	B	(#xx:3 of @Rd16) ← (#xx:3 of @Rd16)			4												8
BNOT #xx:3, @aa:8	B	(#xx:3 of @aa:8) ← (#xx:3 of @aa:8)						4									8
BNOT Rn, Rd	B	(Rn8 of Rd8) ← (Rn8 of Rd8)		2													2
BNOT Rn, @Rd	B	(Rn8 of @Rd16) ← (Rn8 of @Rd16)			4												8
BNOT Rn, @aa:8	B	(Rn8 of @aa:8) ← (Rn8 of @aa:8)						4									8
BTST #xx:3, Rd	B	(#xx:3 of Rd8) → Z		2											↕		2
BTST #xx:3, @Rd	B	(#xx:3 of @Rd16) → Z			4										↕		6
BTST #xx:3, @aa:8	B	(#xx:3 of @aa:8) → Z						4							↕		6
BTST Rn, Rd	B	(Rn8 of Rd8) → Z		2											↕		2
BTST Rn, @Rd	B	(Rn8 of @Rd16) → Z			4										↕		6
BTST Rn, @aa:8	B	(Rn8 of @aa:8) → Z						4							↕		6

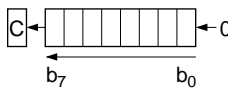
Table A.1 Instruction Set (cont)

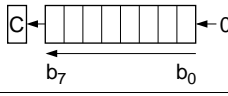
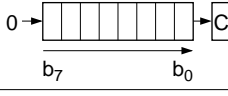
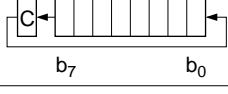
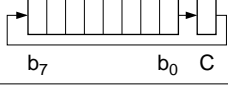
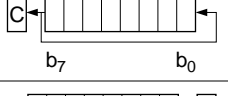
Mnemonic	Operand Size	Operation	Addressing Mode/ Instruction Length								Condition Code					No. of States		
			#xx: 8/16	Rn	@Rn	@(d:16, Rn)	@-Rn/@Rn+	@aa: 8/16	@(d:8, PC)	@@aa	Implied	I	H	N	Z		V	C
BLD #xx:3, Rd	B	(#xx:3 of Rd8) → C		2													↑↓	2
BLD #xx:3, @Rd	B	(#xx:3 of @Rd16) → C			4												↑↓	6
BLD #xx:3, @aa:8	B	(#xx:3 of @aa:8) → C						4									↑↓	6
BILD #xx:3, Rd	B	(#xx:3 of Rd8) → C		2													↑↓	2
BILD #xx:3, @Rd	B	(#xx:3 of @Rd16) → C			4												↑↓	6
BILD #xx:3, @aa:8	B	(#xx:3 of @aa:8) → C						4									↑↓	6
BST #xx:3, Rd	B	C → (#xx:3 of Rd8)		2														2
BST #xx:3, @Rd	B	C → (#xx:3 of @Rd16)			4													8
BST #xx:3, @aa:8	B	C → (#xx:3 of @aa:8)						4										8
BIST #xx:3, Rd	B	\overline{C} → (#xx:3 of Rd8)		2														2
BIST #xx:3, @Rd	B	\overline{C} → (#xx:3 of @Rd16)			4													8
BIST #xx:3, @aa:8	B	\overline{C} → (#xx:3 of @aa:8)						4										8
BAND #xx:3, Rd	B	$C \wedge$ (#xx:3 of Rd8) → C		2													↑↓	2
BAND #xx:3, @Rd	B	$C \wedge$ (#xx:3 of @Rd16) → C			4												↑↓	6
BAND #xx:3, @aa:8	B	$C \wedge$ (#xx:3 of @aa:8) → C						4									↑↓	6
BIAND #xx:3, Rd	B	$C \wedge$ (#xx:3 of Rd8) → C		2													↑↓	2
BIAND #xx:3, @Rd	B	$C \wedge$ (#xx:3 of @Rd16) → C			4												↑↓	6
BIAND #xx:3, @aa:8	B	$C \wedge$ (#xx:3 of @aa:8) → C						4									↑↓	6
BOR #xx:3, Rd	B	$C \vee$ (#xx:3 of Rd8) → C		2													↑↓	2
BOR #xx:3, @Rd	B	$C \vee$ (#xx:3 of @Rd16) → C			4												↑↓	6
BOR #xx:3, @aa:8	B	$C \vee$ (#xx:3 of @aa:8) → C						4									↑↓	6
BIOR #xx:3, Rd	B	$C \vee$ (#xx:3 of Rd8) → C		2													↑↓	2
BIOR #xx:3, @Rd	B	$C \vee$ (#xx:3 of @Rd16) → C			4												↑↓	6
BIOR #xx:3, @aa:8	B	$C \vee$ (#xx:3 of @aa:8) → C						4									↑↓	6
BXOR #xx:3, Rd	B	$C \oplus$ (#xx:3 of Rd8) → C		2													↑↓	2
BXOR #xx:3, @Rd	B	$C \oplus$ (#xx:3 of @Rd16) → C			4												↑↓	6
BXOR #xx:3, @aa:8	B	$C \oplus$ (#xx:3 of @aa:8) → C						4									↑↓	6
BIXOR #xx:3, Rd	B	$C \oplus$ (#xx:3 of Rd8) → C		2													↑↓	2

Table A.1 Instruction Set (cont)

Mnemonic	Operand Size	Operation	Branching Condition	Addressing Mode/ Instruction Length							Condition Code						No. of States		
				#xx: 8/16	Rn	@Rn	@(d:16, Rn)	@-Rn/@Rn+	@aa: 8/16	@(d:8, PC)	@@aa	Implied	I	H	N	Z		V	C
BIXOR #xx:3, @Rd	B	$C \oplus (\#xx:3 \text{ of } @Rd16) \rightarrow C$			4												↕	6	
BIXOR #xx:3, @aa:8	B	$C \oplus (\#xx:3 \text{ of } @aa:8) \rightarrow C$						4									↕	6	
BRA d:8 (BT d:8)	—	$PC \leftarrow PC+d:8$							2									4	
BRN d:8 (BF d:8)	—	$PC \leftarrow PC+2$							2									4	
BHI d:8	—	If condition is true then $PC \leftarrow PC+d:8$ else next;	$C/Z = 0$						2									4	
BLS d:8	—		$C/Z = 1$							2									4
BCC d:8 (BHS d:8)	—		$C = 0$							2									4
BCS d:8 (BLO d:8)	—		$C = 1$							2									4
BNE d:8	—		$Z = 0$							2									4
BEQ d:8	—		$Z = 1$							2									4
BVC d:8	—		$V = 0$							2									4
BVS d:8	—		$V = 1$							2									4
BPL d:8	—		$N = 0$							2									4
BMI d:8	—		$N = 1$							2									4
BGE d:8	—		$N \oplus V = 0$							2									4
BLT d:8	—		$N \oplus V = 1$							2									4
BGT d:8	—		$Z / (N \oplus V) = 0$							2									4
BLE d:8	—		$Z / (N \oplus V) = 1$							2									4
JMP @Rn	—		$PC \leftarrow Rn16$			2													4
JMP @aa:16	—		$PC \leftarrow aa:16$						4										6
JMP @@aa:8	—	$PC \leftarrow @@aa:8$								2								8	
BSR d:8	—	$SP-2 \rightarrow SP$ $PC \rightarrow @SP$ $PC \leftarrow PC+d:8$							2									6	
JSR @Rn	—	$SP-2 \rightarrow SP$ $PC \rightarrow @SP$ $PC \leftarrow Rn16$			2													6	
JSR @aa:16	—	$SP-2 \rightarrow SP$ $PC \rightarrow @SP$ $PC \leftarrow aa:16$						4										8	

Table A.1 Instruction Set (cont)

Mnemonic	Operand Size	Operation	Addressing Mode/ Instruction Length (Bytes)								Condition Code						No. of States
			#xx: 8/16	Rn	@Rn	@(d:16, Rn)	@-Rn/@Rn+	@aa: 8/16	@(d:8, PC)	@@aa	Implied	I	H	N	Z	V	
JSR @@aa:8		SP-2 → SP PC → @SP PC ← @aa:8								2	—	—	—	—	—	—	8
RTS	—	PC ← @SP SP+2 → SP								2	—	—	—	—	—	—	8
RTE	—	CCR ← @SP SP+2 → SP PC ← @SP SP+2 → SP								2	↑	↑	↑	↑	↑	↑	10
SLEEP	—	Transit to sleep mode.								2	—	—	—	—	—	—	2
LDC #xx:8, CCR	B	#xx:8 → CCR	2								↑	↑	↑	↑	↑	↑	2
LDC Rs, CCR	B	Rs8 → CCR		2							↑	↑	↑	↑	↑	↑	2
STC CCR, Rd	B	CCR → Rd8		2							—	—	—	—	—	—	2
ANDC #xx:8, CCR	B	CCR^#xx:8 → CCR	2								↑	↑	↑	↑	↑	↑	2
ORC #xx:8, CCR	B	CCR#xx:8 → CCR	2								↑	↑	↑	↑	↑	↑	2
XORC #xx:8, CCR	B	CCR@#xx:8 → CCR	2								↑	↑	↑	↑	↑	↑	2
NOP	—	PC ← PC+2								2	—	—	—	—	—	—	2

Notes: The number of states is the number of states required for execution when the instruction and its operands are located in on-chip memory.

- (1) Set to "1" when there is a carry or borrow from bit 11; otherwise cleared to "0."
- (2) If the result is zero, the previous value of the flag is retained; otherwise the flag is cleared to "0."
- (3) Set to "1" if decimal adjustment produces a carry; otherwise cleared to "0."
- (4) The number of states required for execution is 4n+8 (n = value of R4L)
- (5) These instructions are not supported by the H8/338 Series.
- (6) Set to "1" if the divisor is negative; otherwise cleared to "0."
- (7) Cleared to "0" if the divisor is not zero; undetermined when the divisor is zero.

A.2 Operation Code Map

Table A.2 is a map of the operation codes contained in the first byte of the instruction code (bits 15 to 8 of the first instruction word).

Some pairs of instructions have identical first bytes. These instructions are differentiated by the first bit of the second byte (bit 7 of the first instruction word).

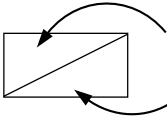

Instruction when first bit of byte 2 (bit 7 of first instruction word) is “0.”

Instruction when first bit of byte 2 (bit 7 of first instruction word) is “1.”

Table A.2 Operation Code Map

Low High	0	1	2	3	4	5	6	7	8	9	A	B	C	D	E	F
0	NOP	SLEEP	STC	LDC	ORC	XORC	ANDC	LDC	ADD	INC	ADDS	MOV	ADDX	DAA		
1	SHLL SHAL	SHLR SHAR	ROTXL ROTL	ROTXR ROTR	OR	XOR	AND	NOT NEG	SUB	DEC	SUBS	CMP	SUBX	DAS		
2	MOV															
3	MOV															
4	BRA	BRN	BHI	BLS	BCC	BCS	BNE	BEQ	BVC	BVS	BPL	BMI	BGE	BLT	BGT	BLE
5	MULXU	DIVXU			RTS	BSR	RTE				JMP				JSR	
6	BSET	BNOT	BCLR	BTST	BOR	BXOR	BAND	BLD	BST							
7					BIOR	BIXOR	BIAND	BILD		MOV		EEPMOV		Bit-manipulation instructions		
8	ADD															
9	ADDX															
A	CMP															
B	SUBX															
C	OR															
D	XOR															
E	AND															
F	MOV															

Note: * The PUSH and POP instructions are identical in machine language to MOV instructions.

A.3 Number of States Required for Execution

The tables below can be used to calculate the number of states required for instruction execution. Table A.3 indicates the number of states required for each cycle (instruction fetch, branch address read, stack operation, byte data access, word data access, internal operation). Table A.4 indicates the number of cycles of each type occurring in each instruction. The total number of states required for execution of an instruction can be calculated from these two tables as follows:

$$\text{Execution states} = I \times S_I + J \times S_J + K \times S_K + L \times S_L + M \times S_M + N \times S_N$$

Examples: Mode 1 (on-chip ROM disabled), stack located in external memory, 1 wait state inserted in external memory access.

1. BSET #0, @FFC7

From table A.4: $I = L = 2, \quad J = K = M = N = 0$

From table A.3: $S_I = 8, \quad S_L = 3$

Number of states required for execution: $2 \times 8 + 2 \times 3 = 22$

2. JSR @@30

From table A.4: $I = 2, \quad J = K = 1, \quad L = M = N = 0$

From table A.3: $S_I = S_J = S_K = 8$

Number of states required for execution: $2 \times 8 + 1 \times 8 + 1 \times 8 = 32$

Table A.3 Number of States Taken by Each Cycle in Instruction Execution

Execution Status (instruction cycle)		Access Location		
		On-chip Memory	On-chip Reg. Field	External Memory
Instruction fetch	S_I	2	6	$6 + 2m$
Branch address read	S_J			
Stack operation	S_K			
Byte data access	S_L		3	$3 + m$
Word data access	S_M		6	$6 + 2m$
Internal operation	S_N		1	

Notes: m: Number of wait states inserted in access to external device.

Table A.4 Number of Cycles in Each Instruction

Instruction	Mnemonic	Instruction	Branch	Stack	Byte Data	Word Data	Internal
		Fetch	Addr. Read	Operation	Access	Access	Operation
		I	J	K	L	M	N
ADD	ADD.B #xx:8, Rd	1					
	ADD.B Rs, Rd	1					
	ADD.W Rs, Rd	1					
ADDS	ADDS.W #1/2, Rd	1					
ADDX	ADDX.B #xx:8, Rd	1					
	ADDX.B Rs, Rd	1					
AND	AND.B #xx:8, Rd	1					
	AND.B Rs, Rd	1					
ANDC	ANDC #xx:8, CCR	1					
BAND	BAND #xx:3, Rd	1					
	BAND #xx:3, @Rd	2			1		
	BAND #xx:3, @aa:8	2			1		
Bcc	BRA d:8 (BT d:8)	2					
	BRN d:8 (BF d:8)	2					
	BHI d:8	2					
	BLS d:8	2					
	BCC d:8 (BHS d:8)	2					
	BCS d:8 (BLO d:8)	2					
	BNE d:8	2					
	BEQ d:8	2					
	BVC d:8	2					
	BVS d:8	2					
	BPL d:8	2					
	BMI d:8	2					
	BGE d:8	2					
	BLT d:8	2					
	BGT d:8	2					
BLE d:8	2						
BCLR	BCLR #xx:3, Rd	1					
	BCLR #xx:3, @Rd	2			2		
	BCLR #xx:3, @aa:8	2			2		
	BCLR Rn, Rd	1					
	BCLR Rn, @Rd	2			2		
	BCLR Rn, @aa:8	2			2		

Note: All values left blank are zero.

Table A.4 Number of Cycles in Each Instruction (cont)

Instruction	Mnemonic	Instruction	Branch	Stack	Byte Data	Word Data	Internal
		Fetch	Addr. Read	Operation	Access	Access	Operation
		I	J	K	L	M	N
BIAND	BIAND #xx:3, Rd	1					
	BIAND #xx:3, @Rd	2			1		
	BIAND #xx:3, @aa:8	2			1		
BILD	BILD #xx:3, Rd	1					
	BILD #xx:3, @Rd	2			1		
	BILD #xx:3, @aa:8	2			1		
BIOR	BIOR #xx:3, Rd	1					
	BIOR #xx:3, @Rd	2			1		
	BIOR #xx:3, @aa:8	2			1		
BIST	BIST #xx:3, Rd	1					
	BIST #xx:3, @Rd	2			2		
	BIST #xx:3, @aa:8	2			2		
BIXOR	BIXOR #xx:3, Rd	1					
	BIXOR #xx:3, @Rd	2			1		
	BIXOR #xx:3, @aa:8	2			1		
BLD	BLD #xx:3, Rd	1					
	BLD #xx:3, @Rd	2			1		
	BLD #xx:3, @aa:8	2			1		
BNOT	BNOT #xx:3, Rd	1					
	BNOT #xx:3, @Rd	2			2		
	BNOT #xx:3, @aa:8	2			2		
	BNOT Rn, Rd	1					
	BNOT Rn, @Rd	2			2		
	BNOT Rn, @aa:8	2			2		
BOR	BOR #xx:3, Rd	1					
	BOR #xx:3, @Rd	2			1		
	BOR #xx:3, @aa:8	2			1		
BSET	BSET #xx:3, Rd	1					
	BSET #xx:3, @Rd	2			2		
	BSET #xx:3, @aa:8	2			2		
	BSET Rn, Rd	1					
	BSET Rn, @Rd	2			2		
	BSET Rn, @aa:8	2			2		

Note: All values left blank are zero.

Table A.4 Number of Cycles in Each Instruction (cont)

Instruction	Mnemonic	Instruction	Branch	Stack	Byte Data	Word Data	Internal
		Fetch	Addr. Read	Operation	Access	Access	Operation
		I	J	K	L	M	N
BSR	BSR d:8	2		1			
BST	BST #xx:3, Rd	1					
	BST #xx:3, @Rd	2			2		
	BST #xx:3, @aa:8	2			2		
BTST	BTST #xx:3, Rd	1					
	BTST #xx:3, @Rd	2			1		
	BTST #xx:3, @aa:8	2			1		
	BTST Rn, Rd	1					
	BTST Rn, @Rd	2			1		
	BTST Rn, @aa:8	2			1		
BXOR	BXOR #xx:3, Rd	1					
	BXOR #xx:3, @Rd	2			1		
	BXOR #xx:3, @aa:8	2			1		
CMP	CMP.B #xx:8, Rd	1					
	CMP.B Rs, Rd	1					
	CMP.W Rs, Rd	1					
DAA	DAA.B Rd	1					
DAS	DAS.B Rd	1					
DEC	DEC.B Rd	1					
DIVXU	DIVXU.B Rs, Rd	1					12
EEMOV	EEMOV	2			2n+2*		1
INC	INC.B Rd	1					
JMP	JMP @Rn	2					
	JMP @aa:16	2					2
	JMP @@aa:8	2	1				2
JSR	JSR @Rn	2		1			
	JSR @aa:16	2		1			2
	JSR @@aa:8	2	1	1			
LDC	LDC #xx:8, CCR	1					
	LDC Rs, CCR	1					
MOV	MOV.B #xx:8, Rd	1					
	MOV.B Rs, Rd	1					
	MOV.B @Rs, Rd	1			1		
	MOV.B @(d:16, Rs), Rd	2			1		

Notes: All values left blank are zero.

* n: Initial value in R4L. Source and destination are accessed n + 1 times each.

Table A.4 Number of Cycles in Each Instruction (cont)

Instruction	Mnemonic	Instruction	Branch	Stack	Byte Data	Word Data	Internal	
		Fetch	Addr. Read	Operation	Access	Access	Operation	
		I	J	K	L	M	N	
MOV	MOV.B @Rs+, Rd	1			1		2	
	MOV.B @aa:8, Rd	1			1			
	MOV.B @aa:16, Rd	2			1			
	MOV.B Rs, @Rd	1			1			
	MOV.B Rs, @(d:16, Rd)	2			1			
	MOV.B Rs, @-Rd	1			1		2	
	MOV.B Rs, @aa:8	1			1			
	MOV.B Rs, @aa:16	2			1			
	MOV.W #xx:16, Rd	2						
	MOV.W Rs, Rd	1						
	MOV.W @Rs, Rd	1					1	
	MOV.W @(d:16, Rs), Rd	2					1	
	MOV.W @Rs+, Rd	1					1	2
	MOV.W @aa:16, Rd	2					1	
	MOV.W Rs, @Rd	1					1	
	MOV.W Rs, @(d:16, Rd)	2					1	
	MOV.W Rs, @-Rd	1					1	2
MOV.W Rs, @aa:16	2					1		
MOVFPPE	MOVFPPE @aa:16, Rd	Not supported						
MOVTPPE	MOVTPPE.Rs, @aa:16	Not supported						
MULXU	MULXU.Rs, Rd	1					12	
NEG	NEG.B Rd	1						
NOP	NOP	1						
NOT	NOT.B Rd	1						
	OR.B Rs, Rd	1						
OR	OR.B #xx:8, Rd	1						
	OR.B Rs, Rd	1						
ORC	ORC #xx:8, CCR	1						
POP	POP Rd	1		1			2	
PUSH	PUSH Rs	1		1			2	
ROTL	ROTL.B Rd	1						
ROTR	ROTR.B Rd	1						
ROTXL	ROTXL.B Rd	1						
ROTXR	ROTXR.B Rd	1						
RTE	RTE	2		2			2	
RTS	RTS	2		1			2	

Note: All values left blank are zero.

Table A.4 Number of Cycles in Each Instruction (cont)

Instruction	Mnemonic	Instruction	Branch	Stack	Byte Data	Word Data	Internal
		Fetch	Addr. Read	Operation	Access	Access	Operation
		I	J	K	L	M	N
SHAL	SHAL.B Rd	1					
SHAR	SHAR.B Rd	1					
SHLL	SHLL.B Rd	1					
SHLR	SHLR.B Rd	1					
SLEEP	SLEEP	1					
STC	STC CCR, Rd	1					
SUB	SUB.B Rs, Rd	1					
	SUB.W Rs, Rd	1					
SUBS	SUBS.W #1/2, Rd	1					
SUBX	SUBX.B #xx:8, Rd	1					
	SUBX.B Rs, Rd	1					
XOR	XOR.B #xx:8, Rd	1					
	XOR.B Rs, Rd	1					
XORC	XORC #xx:8, CCR	1					

Note: All values left blank are zero.

Appendix B Register Field

B.1 Register Addresses and Bit Names

Addr. (last byte)	Register Name	Bit Names								Module
		Bit 7	Bit 6	Bit 5	Bit 4	Bit 3	Bit 2	Bit 1	Bit 0	
H'80										External addresses (in expanded modes)
H'81										
H'82										
H'83										
H'84										
H'85										
H'86										
H'87										
H'88	SMR	C/ \bar{A}	CHR	PE	O/ \bar{E}	STOP	MP	CKS1	CKS0	SCI1
H'89	BRR									
H'8A	SCR	TIE	RIE	TE	RE	MPIE	TEIE	CKE1	CKE0	
H'8B	TDR									
H'8C	SSR	TDRE	RDRF	ORER	FER	PER	TEND	MPB	MPBT	
H'8D	RDR									
H'8E										
H'8F										
H'90	TIER	ICIAE	ICIBE	ICICE	ICIDE	OCIAE	OCIBE	OVIE	—	FRT
H'91	TCSR	ICFA	ICFB	ICFC	ICFD	OCFA	OCFB	OVF	CCLRA	
H'92	FRC (H)									
H'93	FRC (L)									
H'94	OCRA (H)									
	OCRB (H)									
H'95	OCRA (L)									
	OCRB (L)									
H'96	TCR	IEDGA	IEDGB	IEDGC	IEDGD	BUFEA	BUFEB	CKS1	CKS0	
H'97	TOCR	—	—	—	OCSR	OEA	OEB	OLVLA	OLVLB	
H'98	ICRA (H)									
H'99	ICRA (L)									
H'9A	ICRB (H)									
H'9B	ICRB (L)									
H'9C	ICRC (H)									
H'9D	ICRC (L)									
H'9E	ICRD (H)									
H'9F	ICRD (L)									

Notes: FRT: Free-Running Timer

SCI1: Serial Communication Interface 1

Addr. (last byte)	Register Name	Bit Names								Module
		Bit 7	Bit 6	Bit 5	Bit 4	Bit 3	Bit 2	Bit 1	Bit 0	
H'A0	TCR	OE	OS	—	—	—	CKS2	CKS1	CKS0	PWM0
H'A1	DTR									
H'A2	TCNT									
H'A3	—	—	—	—	—	—	—	—	—	
H'A4	TCR	OE	OS	—	—	—	CKS2	CKS1	CKS0	PWM1
H'A5	DTR									
H'A6	TCNT									
H'A7	—	—	—	—	—	—	—	—	—	
H'A8	DADR0									D/A
H'A9	DADR1									
H'AA	DACR	DAOE1	DAOE0	DAE	—	—	—	—	—	
H'AB	—	—	—	—	—	—	—	—	—	
H'AC	P1PCR	P1 ₇ PCR	P1 ₆ PCR	P1 ₅ PCR	P1 ₄ PCR	P1 ₃ PCR	P1 ₂ PCR	P1 ₁ PCR	P1 ₀ PCR	Port 1
H'AD	P2PCR	P2 ₇ PCR	P2 ₆ PCR	P2 ₅ PCR	P2 ₄ PCR	P2 ₃ PCR	P2 ₂ PCR	P2 ₁ PCR	P2 ₀ PCR	Port 2
H'AE	P3PCR	P3 ₇ PCR	P3 ₆ PCR	P3 ₅ PCR	P3 ₄ PCR	P3 ₃ PCR	P3 ₂ PCR	P3 ₁ PCR	P3 ₀ PCR	Port 3
H'AF	—	—	—	—	—	—	—	—	—	—
H'B0	P1DDR	P1 ₇ DDR	P1 ₆ DDR	P1 ₅ DDR	P1 ₄ DDR	P1 ₃ DDR	P1 ₂ DDR	P1 ₁ DDR	P1 ₀ DDR	Port 1
H'B1	P2DDR	P2 ₇ DDR	P2 ₆ DDR	P2 ₅ DDR	P2 ₄ DDR	P2 ₃ DDR	P2 ₂ DDR	P2 ₁ DDR	P2 ₀ DDR	Port 2
H'B2	P1DR	P1 ₇	P1 ₆	P1 ₅	P1 ₄	P1 ₃	P1 ₂	P1 ₁	P1 ₀	Port 1
H'B3	P2DR	P2 ₇	P2 ₆	P2 ₅	P2 ₄	P2 ₃	P2 ₂	P2 ₁	P2 ₀	Port 2
H'B4	P3DDR	P3 ₇ DDR	P3 ₆ DDR	P3 ₅ DDR	P3 ₄ DDR	P3 ₃ DDR	P3 ₂ DDR	P3 ₁ DDR	P3 ₀ DDR	Port 3
H'B5	P4DDR	P4 ₇ DDR	P4 ₆ DDR	P4 ₅ DDR	P4 ₄ DDR	P4 ₃ DDR	P4 ₂ DDR	P4 ₁ DDR	P4 ₀ DDR	Port 4
H'B6	P3DR	P3 ₇	P3 ₆	P3 ₅	P3 ₄	P3 ₃	P3 ₂	P3 ₁	P3 ₀	Port 3
H'B7	P4DR	P4 ₇	P4 ₆	P4 ₅	P4 ₄	P4 ₃	P4 ₂	P4 ₁	P4 ₀	Port 4
H'B8	P5DDR	—	—	—	—	—	P5 ₂ DDR	P5 ₁ DDR	P5 ₀ DDR	Port 5
H'B9	P6DDR	P6 ₇ DDR	P6 ₆ DDR	P6 ₅ DDR	P6 ₄ DDR	P6 ₃ DDR	P6 ₂ DDR	P6 ₁ DDR	P6 ₀ DDR	Port 6
H'BA	P5DR	—	—	—	—	—	P5 ₂	P5 ₁	P5 ₀	Port 5
H'BB	P6DR	P6 ₇	P6 ₆	P6 ₅	P6 ₄	P6 ₃	P6 ₂	P6 ₁	P6 ₀	Port 6
H'BC	—	—	—	—	—	—	—	—	—	—
H'BD	P8DDR	—	P8 ₆ DDR	P8 ₅ DDR	P8 ₄ DDR	P8 ₃ DDR	P8 ₂ DDR	P8 ₁ DDR	P8 ₀ DDR	Port 8
H'BE	P7DR	P7 ₇	P7 ₆	P7 ₅	P7 ₄	P7 ₃	P7 ₂	P7 ₁	P7 ₀	Port 7
H'BF	P8DR	—	P8 ₆	P8 ₅	P8 ₄	P8 ₃	P8 ₂	P8 ₁	P8 ₀	Port 8

Notes: PWM0: Pulse-Width Modulation timer channel 0

PWM1: Pulse-Width Modulation timer channel 1

D/A: D/A converter

Addr. (last byte)	Register Name	Bit Names								Module
		Bit 7	Bit 6	Bit 5	Bit 4	Bit 3	Bit 2	Bit 1	Bit 0	
H'C0	P9DDR	P9 ₇ DDR	P9 ₆ DDR	P9 ₅ DDR	P9 ₄ DDR	P9 ₃ DDR	P9 ₂ DDR	P9 ₁ DDR	P9 ₀ DDR	Port 9
H'C1	P9DR	P9 ₇	P9 ₆	P9 ₅	P9 ₄	P9 ₃	P9 ₂	P9 ₁	P9 ₀	
H'C2	—	—	—	—	—	—	—	—	—	
H'C3	STCR	—	—	—	—	—	MPE	ICKS1	ICKS0	
H'C4	SYSCR	SSBY	STS2	STS1	STS0	—	NMIEG	DPME	RAME	System control
H'C5	MDCR	—	—	—	—	—	—	MDS1	MDS0	
H'C6	ISCR	IRQ ₇ SC	IRQ ₆ SC	IRQ ₅ SC	IRQ ₄ SC	IRQ ₃ SC	IRQ ₂ SC	IRQ ₁ SC	IRQ ₀ SC	
H'C7	IER	IRQ ₇ E	IRQ ₆ E	IRQ ₅ E	IRQ ₄ E	IRQ ₃ E	IRQ ₂ E	IRQ ₁ E	IRQ ₀ E	
H'C8	TCR	CMIEB	CMIEA	OVIE	CCLR1	CCLR0	CKS2	CKS1	CKS0	TMR0
H'C9	TCSR	CMFB	CMFA	OVF	—	OS3	OS2	OS1	OS0	
H'CA	TCORA									
H'CB	TCORB									
H'CC	TCNT									
H'CD	—	—	—	—	—	—	—	—	—	
H'CE	—	—	—	—	—	—	—	—	—	
H'CF	—	—	—	—	—	—	—	—	—	
H'D0	TCR	CMIEB	CMIEA	OVIE	CCLR1	CCLR0	CKS2	CKS1	CKS0	TMR1
H'D1	TCSR	CMFB	CMFA	OVF	—	OS3	OS2	OS1	OS0	
H'D2	TCORA									
H'D3	TCORB									
H'D4	TCNT									
H'D5	—	—	—	—	—	—	—	—	—	
H'D6	—	—	—	—	—	—	—	—	—	
H'D7	—	—	—	—	—	—	—	—	—	
H'D8	SMR	C/ \bar{A}	CHR	PE	O/ \bar{E}	STOP	MP	CKS1	CKS0	SCI0
H'D9	BRR									
H'DA	SCR	TIE	RIE	TE	RE	MPIE	TEIE	CKE1	CKE0	
H'DB	TDR									
H'DC	SSR	TDRE	RDRF	ORER	FER	PER	TEND	MPB	MPBT	
H'DD	RDR									
H'DE	—	—	—	—	—	—	—	—	—	
H'DF	—	—	—	—	—	—	—	—	—	

Notes: TMR0: 8-Bit Timer channel 0

TMR1: 8-Bit Timer channel 1

SCI0: Serial Communication Interface 0

Addr. (last byte)	Register Name	Bit Names								Module
		Bit 7	Bit 6	Bit 5	Bit 4	Bit 3	Bit 2	Bit 1	Bit 0	
H'E0	ADDRA									A/D
H'E1	—	—	—	—	—	—	—	—	—	
H'E2	ADDRB									
H'E3	—	—	—	—	—	—	—	—	—	
H'E4	ADDRC									
H'E5	—	—	—	—	—	—	—	—	—	
H'E6	ADDRD									
H'E7	—	—	—	—	—	—	—	—	—	
H'E8	ADCSR	ADF	ADIE	ADST	SCAN	CKS	CH2	CH1	CH0	
H'E9	—	—	—	—	—	—	—	—	—	
H'EA	ADCR	TRGE	—	—	—	—	—	—	CHS	
H'EB	—	—	—	—	—	—	—	—	—	
H'EC	—	—	—	—	—	—	—	—	—	—
H'ED	—	—	—	—	—	—	—	—	—	
H'EE	—	—	—	—	—	—	—	—	—	
H'EF	—	—	—	—	—	—	—	—	—	
H'F0	—	—	—	—	—	—	—	—	—	—
H'F1	—	—	—	—	—	—	—	—	—	
H'F2	—	—	—	—	—	—	—	—	—	
H'F3	—	—	—	—	—	—	—	—	—	
H'F4	—	—	—	—	—	—	—	—	—	
H'F5	—	—	—	—	—	—	—	—	—	
H'F6	—	—	—	—	—	—	—	—	—	
H'F7	—	—	—	—	—	—	—	—	—	
H'F8	—	—	—	—	—	—	—	—	—	
H'F9	—	—	—	—	—	—	—	—	—	
H'FA	—	—	—	—	—	—	—	—	—	
H'FB	—	—	—	—	—	—	—	—	—	
H'FC	—	—	—	—	—	—	—	—	—	
H'FD	—	—	—	—	—	—	—	—	—	
H'FE	—	—	—	—	—	—	—	—	—	
H'FF	—	—	—	—	—	—	—	—	—	

Note: A/D: Analog-to-Digital converter

B.2 Register Descriptions

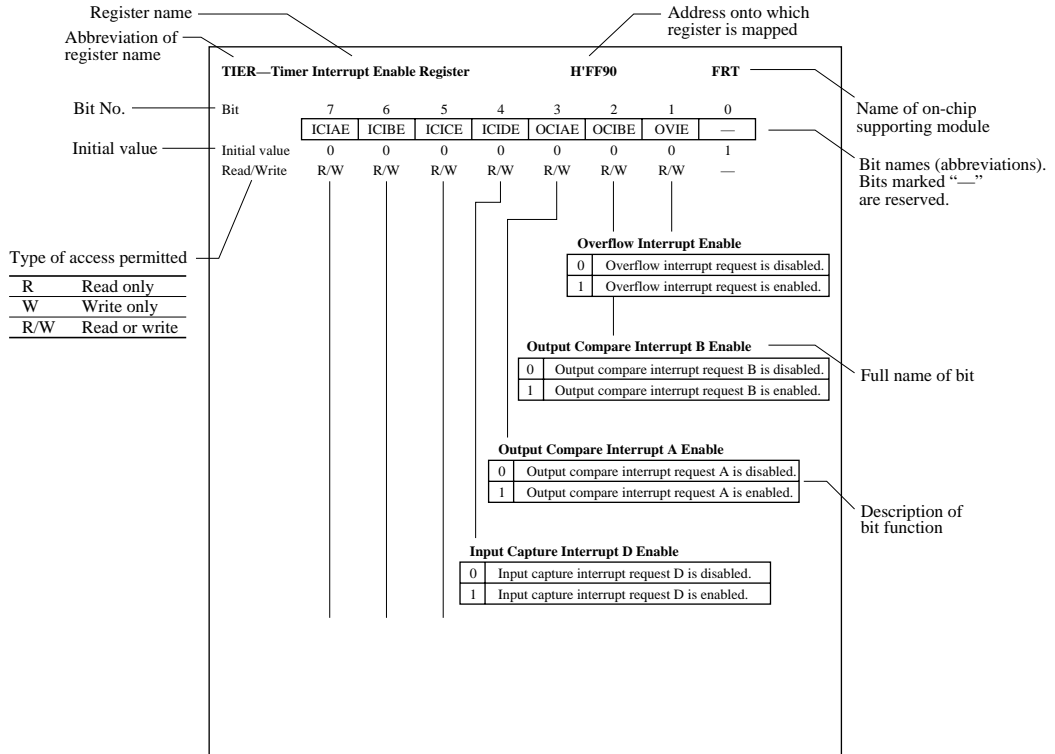

SMR—Serial Mode Register

H'FF88

SCI1

Bit	7	6	5	4	3	2	1	0
	C/ \bar{A}	CHR	PE	O/ \bar{E}	STOP	MP	CKS1	CKS0
Initial value	0	0	0	0	0	0	0	0
Read/Write	R/W	R/W	R/W	R/W	R/W	R/W	R/W	R/W

Clock select

0	0	\emptyset clock
	1	$\emptyset/4$ clock
1	0	$\emptyset/16$ clock
	1	$\emptyset/64$ clock

Multiprocessor mode

0	Multiprocessor function disabled
1	Multiprocessor format selected

Stop bit length

0	One stop bit
1	Two stop bits

Parity mode

0	Even parity
1	Odd parity

Parity enable

0	Transmit: No parity bit added. Receive: Parity bit not checked.
1	Transmit: No parity bit added. Receive: Parity bit not checked.

Character length

0	8-bit data length
1	7-bit data length

Communication mode

0	Asynchronous
1	Synchronous

BRR—Bit Rate Register

H'FF89

SCI1

Bit	7	6	5	4	3	2	1	0
Initial value	1	1	1	1	1	1	1	1
Read/Write	R/W	R/W	R/W	R/W	R/W	R/W	R/W	R/W

Constant that determines the bit rate

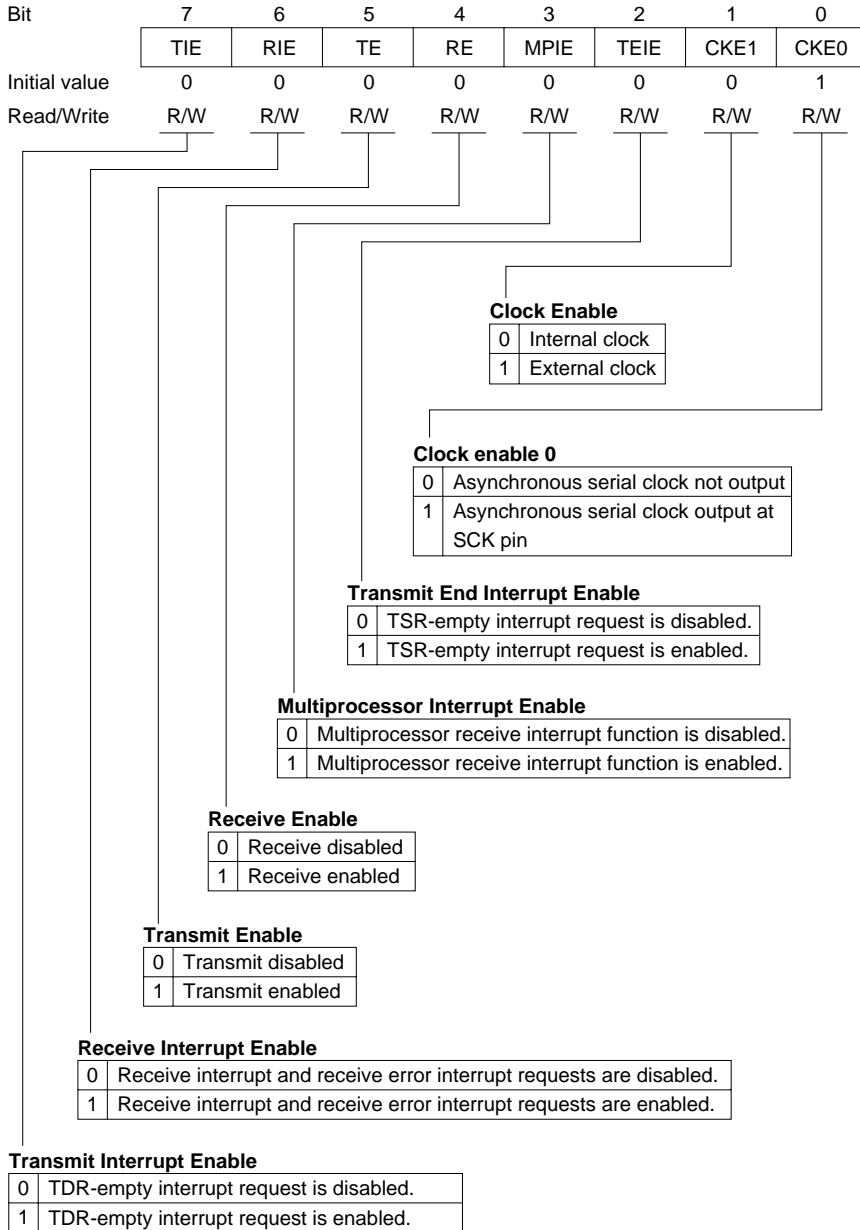

TDR—Transmit Data Register

H'FF8B

SCI1

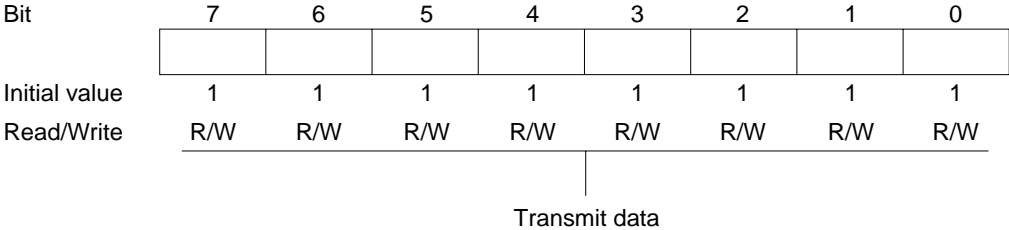

Bit	7	6	5	4	3	2	1	0
	TDRE	RDRF	ORER	FER	PER	TEND	MPB	MPBT
Initial value	1	0	0	0	0	1	0	0
Read/Write	R/(W)*	R/(W)*	R/(W)*	R/(W)*	R/(W)*	R	R	R/W

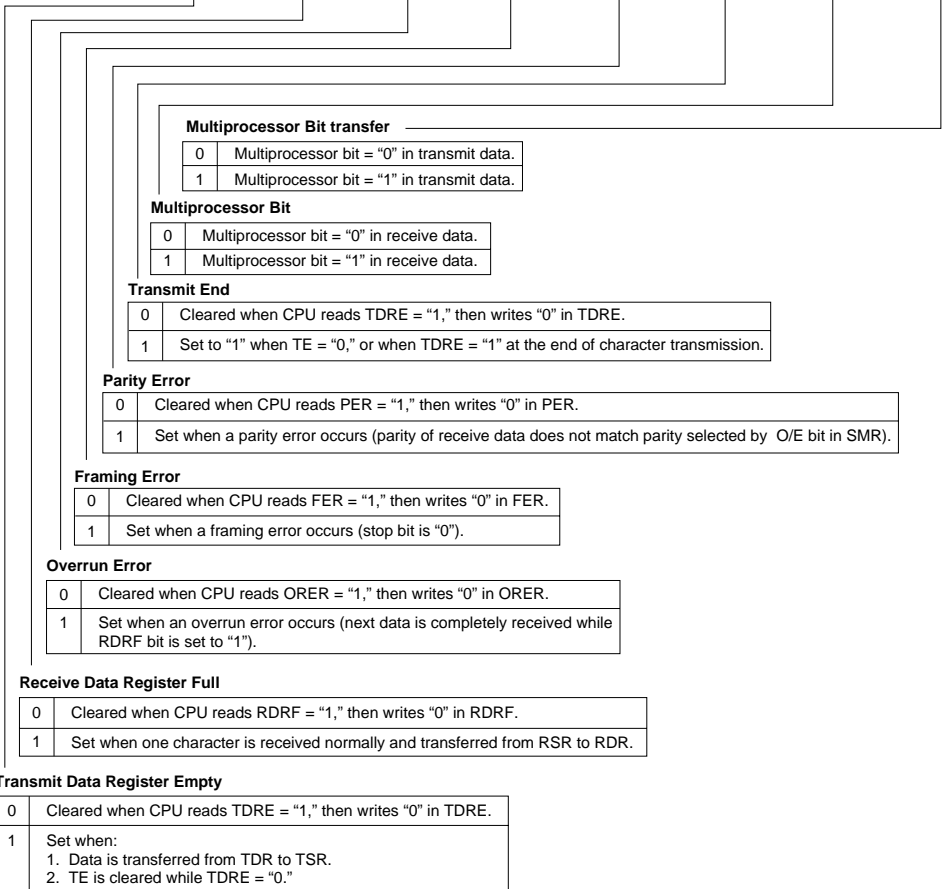

Note: * Software can write a "0" in bits 7 to 3 to clear the flags, but cannot write a "1" in these bits.

RDR—Receive Data Register**H'FF8D****SCI1**

Bit	7	6	5	4	3	2	1	0
Initial value	0	0	0	0	0	0	0	0
Read/Write	R	R	R	R	R	R	R	R

|
Receive data

TIER—Timer Interrupt Enable Register

H'FF90

FRT

Bit	7	6	5	4	3	2	1	0
	ICIAE	ICIBE	ICICE	ICIDE	OCIAE	OCIBE	OVIE	—
Initial value	0	0	0	0	0	0	0	1
Read/Write	R/W	R/W	R/W	R/W	R/W	R/W	R/W	—

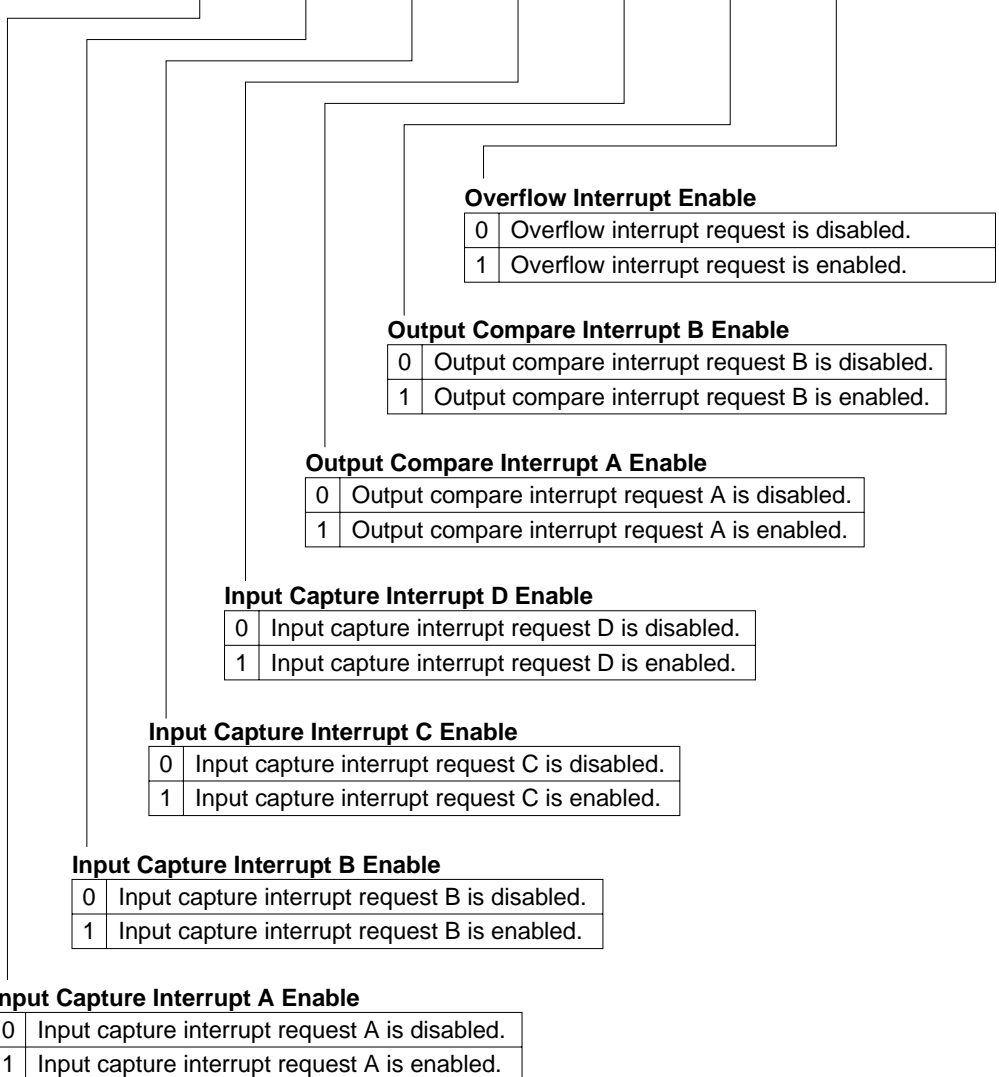

TCSR—Timer Control/Status Register

H'FF91

FRT

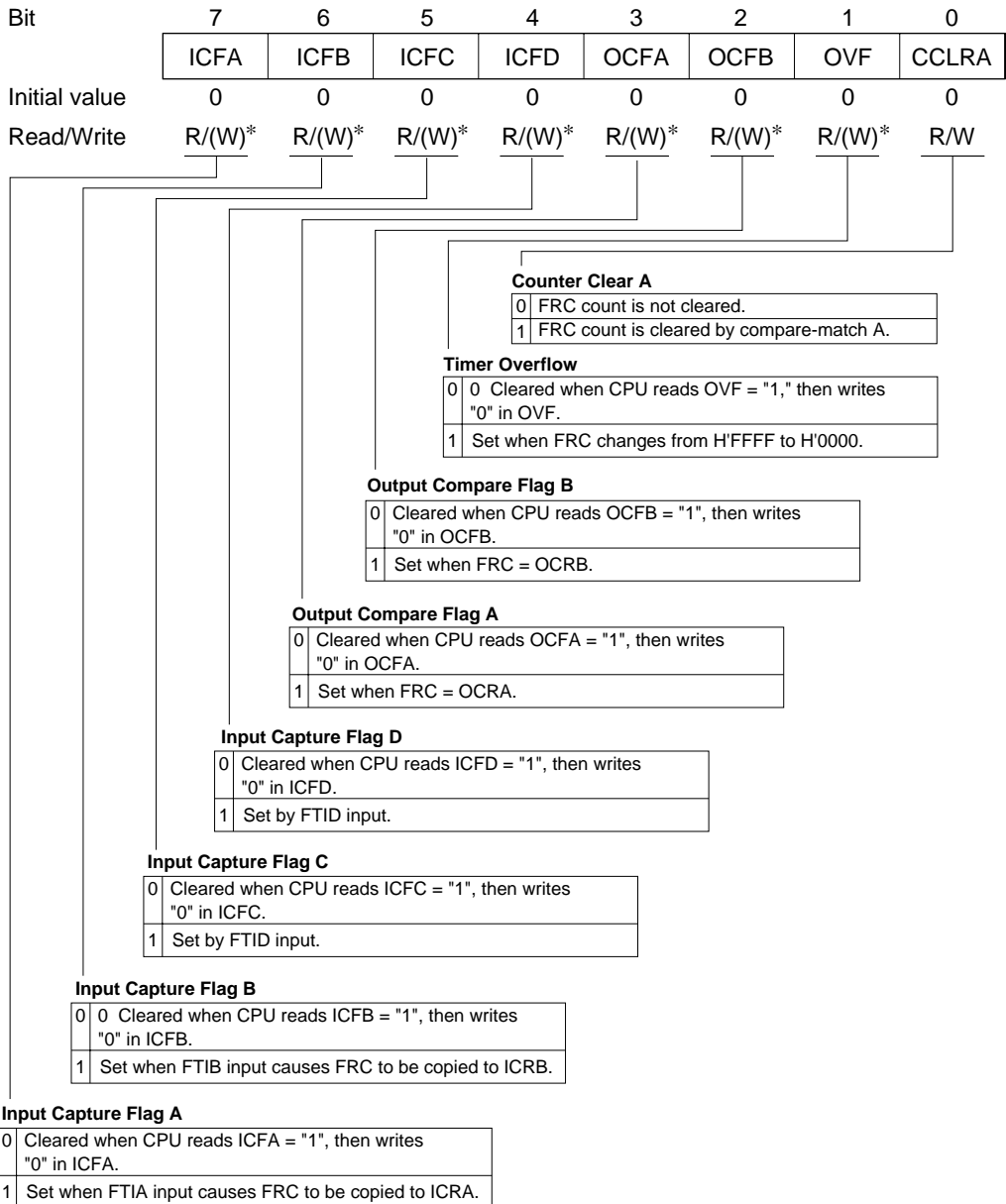

Note: * Software can write a "0" in bits 7 to 1 to clear the flags, but cannot write a "1" in these bits.

FRC (H and L)—Free-Running Counter**H'FF92, H'FF93****FRT**

Bit	7	6	5	4	3	2	1	0
Initial value	0	0	0	0	0	0	0	0
Read/Write	R/W	R/W	R/W	R/W	R/W	R/W	R/W	R/W

Count value

OCRA (H and L)—Output Compare Register A**H'FF94, H'FF95****FRT**

Bit	7	6	5	4	3	2	1	0
Initial value	1	1	1	1	1	1	1	1
Read/Write	R/W	R/W	R/W	R/W	R/W	R/W	R/W	R/W

Continually compared with FRC. OCFA is set to "1" when OCRA=FRC.

OCRB (H and L)—Output Compare Register B**H'FF94, H'FF95****FRT**

Bit	7	6	5	4	3	2	1	0
Initial value	1	1	1	1	1	1	1	1
Read/Write	R/W	R/W	R/W	R/W	R/W	R/W	R/W	R/W

Continually compared with FRC. OCFB is set to "1" when OCRB=FRC.

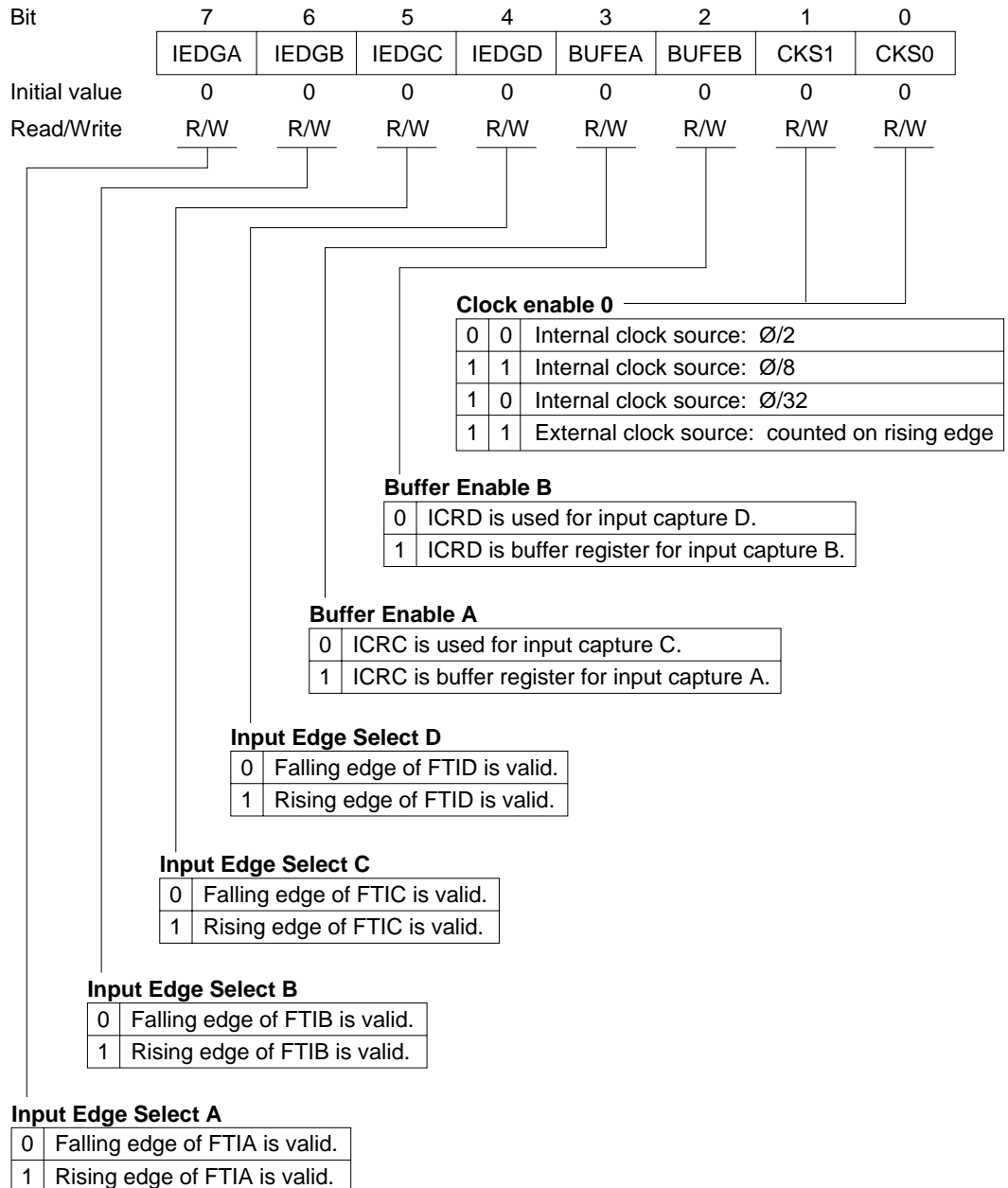

TOCR—Timer Output Compare Control Register

H'FF97

FRT

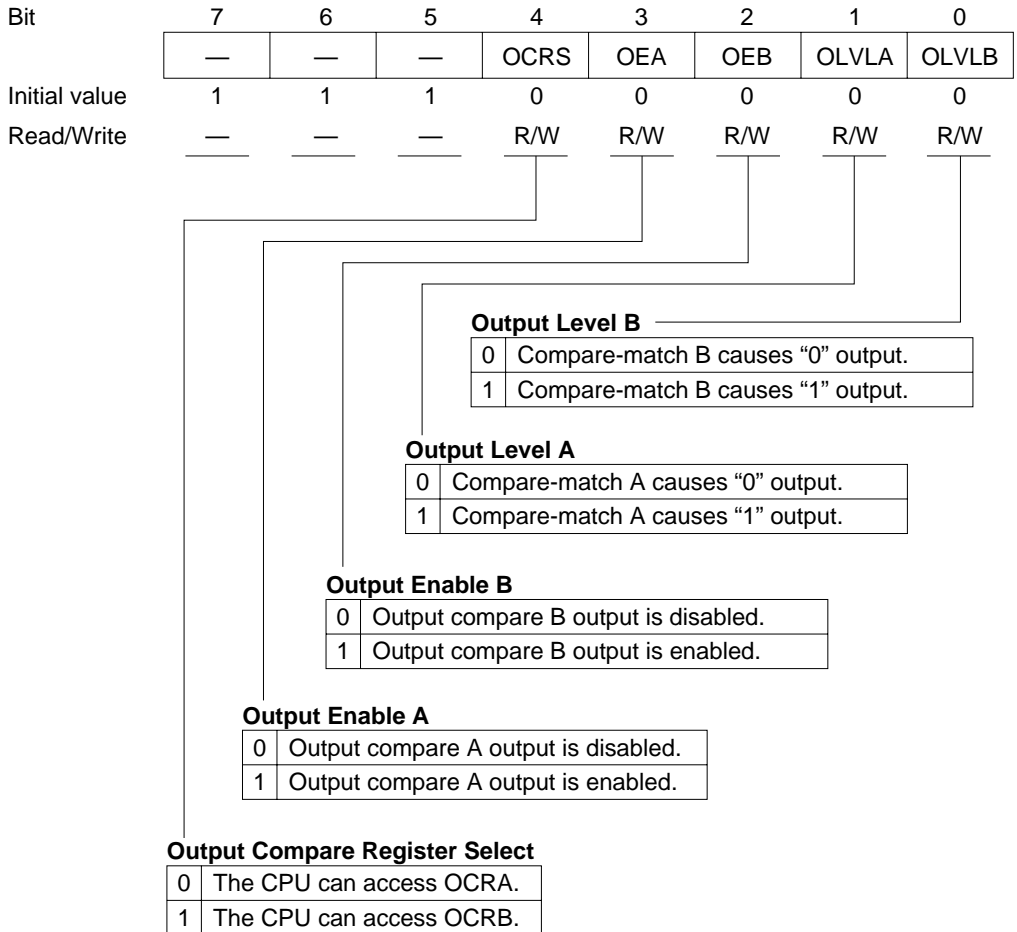

ICRA (H and L)—Input Capture Register A

H'FF98, H'FF99

FRT

Bit	7	6	5	4	3	2	1	0
Initial value	0	0	0	0	0	0	0	0
Read/Write	R	R	R	R	R	R	R	R

Contains FRC count captured on FTIA input.

ICRB (H and L)—Input Capture Register B **H'FF9A, H'FF9B** **FRT**

Bit	7	6	5	4	3	2	1	0
Initial value	0	0	0	0	0	0	0	0
Read/Write	R	R	R	R	R	R	R	R

Contains FRC count captured on FTIB input.

ICRC (H and L)—Input Capture Register C **H'FF9C, H'FF9D** **FRT**

Bit	7	6	5	4	3	2	1	0
Initial value	0	0	0	0	0	0	0	0
Read/Write	R	R	R	R	R	R	R	R

Contains FRC count captured on FTIC input, or old ICRA value in buffer mode.

ICRD (H and L)—Input Capture Register D **H'FF9E, H'FF9F** **FRT**

Bit	7	6	5	4	3	2	1	0
Initial value	0	0	0	0	0	0	0	0
Read/Write	R	R	R	R	R	R	R	R

Contains FRC count captured on FTID input, or old ICRB value in buffer mode.

TCR—Timer Control Register

H'FFA0

PWM0

Bit	7	6	5	4	3	2	1	0
	OE	OS	—	—	—	CKS2	CKS1	CKS0
Initial value	0	0	1	1	1	0	0	0
Read/Write	R/W	R/W	—	—	—	R/W	R/W	R/W

Clock Select (Values When $\emptyset = 10$ MHz)

			Internal clock Freq.	Resolution	PWM period	PWM frequency
0	0	0	$\emptyset/2$	200ns	50 μ s	20kHz
0	0	1	$\emptyset/8$	800ns	200 μ s	5kHz
0	1	0	$\emptyset/32$	3.2 μ s	800 μ s	1.25kHz
0	1	1	$\emptyset/128$	12.8 μ s	3.2ms	312.5Hz
1	0	0	$\emptyset/256$	25.6 μ s	6.4ms	156.3Hz
1	0	1	$\emptyset/1024$	102.4 μ s	25.6ms	39.1Hz
1	1	0	$\emptyset/2048$	204.8 μ s	51.2ms	19.5Hz
1	1	1	$\emptyset/4096$	409.6 μ s	102.4ms	9.8Hz

Output Select

0	Positive logic
1	Negative logic

Output Enable

0	PWM output disabled; TCNT cleared to H'00 and stops.
1	PWM output enabled; TCNT runs.

DTR—Duty Register

H'FFA1

PWM0

Bit	7	6	5	4	3	2	1	0
Initial value	1	1	1	1	1	1	1	1
Read/Write	R/W	R/W	R/W	R/W	R/W	R/W	R/W	R/W

Pulse duty cycle

TCNT—Timer Counter**H'FFA2****PWM0**

Bit	7	6	5	4	3	2	1	0
Initial value	0	0	0	0	0	0	0	0
Read/Write	R/W	R/W	R/W	R/W	R/W	R/W	R/W	R/W

Count value (runs from H'00 to H'F9, then repeats from H'00)

TCR—Timer Control Register**H'FFA4****PWM1**

Bit	7	6	5	4	3	2	1	0
	OE	OW	—	—	—	CKS2	CKS1	CKS0
Initial value	0	0	1	1	1	0	0	0
Read/Write	R/W	R/W	—	—	—	R/W	R/W	R/W

Note: Bit functions are the same as for PWM0.

DTR—Duty Register**H'FFA5****PWM1**

Bit	7	6	5	4	3	2	1	0
Initial value	1	1	1	1	1	1	1	1
Read/Write	R/W	R/W	R/W	R/W	R/W	R/W	R/W	R/W

Note: Bit functions are the same as for PWM0.

TCNT—Timer Counter**H'FFA6****PWM1**

Bit	7	6	5	4	3	2	1	0
Initial value	0	0	0	0	0	0	0	0
Read/Write	R/W	R/W	R/W	R/W	R/W	R/W	R/W	R/W

Note: Bit functions are the same as for PWM0.

DADR0—D/A Data Register 0**H'FFA8****D/A**

Bit	7	6	5	4	3	2	1	0
Initial value	0	0	0	0	0	0	0	0
Read/Write	R/W	R/W	R/W	R/W	R/W	R/W	R/W	R/W

Data to be converted

DADR1—D/A Data Register 1**H'FFA9****D/A**

Bit	7	6	5	4	3	2	1	0
Initial value	0	0	0	0	0	0	0	0
Read/Write	R/W	R/W	R/W	R/W	R/W	R/W	R/W	R/W

Data to be converted

DACR—D/A Control Register**H'FFAA****D/A**

Bit	7	6	5	4	3	2	1	0
	DAOE1	DAOE0	DAE	—	—	—	—	—
Initial value	0	0	0	1	1	1	1	1
Read/Write	R/W	R/W	R/W	—	—	—	—	—

DAOE1	DAOE0	DAE	D/A Analog Output
0	0	0	Channels 0 and 1 disabled.
0	1	0	Channel 0 disabled, channel 1 enabled.
0	1	1	Channels 0 and 1 enabled.
1	0	0	Channel 0 enabled, channel 1 disabled.
1	0	1	Channels 0 and 1 enabled.
1	1	—	Channels 0 and 1 enabled.

P1PCR—Port 1 Input Pull-Up Control Register**H'FFAC****Port 1**

Bit	7	6	5	4	3	2	1	0
	P17PCR	P16PCR	P15PCR	P14PCR	P13PCR	P12PCR	P11PCR	P10PCR
Initial value	0	0	0	0	0	0	0	0
Read/Write	R/W	R/W	R/W	R/W	R/W	R/W	R/W	R/W

Port 1 Input Pull-Up Control

1	Input pull-up transistor is off.
2	Input pull-up transistor is on.

P2PCR—Port 2 Input Pull-Up Control Register**H'FFAD****Port 2**

Bit	7	6	5	4	3	2	1	0
	P27PCR	P26PCR	P25PCR	P24PCR	P23PCR	P22PCR	P21PCR	P20PCR
Initial value	0	0	0	0	0	0	0	0
Read/Write	R/W	R/W	R/W	R/W	R/W	R/W	R/W	R/W

Port 2 Input Pull-Up Control

0	Input pull-up transistor is off.
1	Input pull-up transistor is on.

P3PCR—Port 3 Input Pull-Up Control Register**H'FFAE****Port 3**

Bit	7	6	5	4	3	2	1	0
	P37PCR	P36PCR	P35PCR	P34PCR	P33PCR	P32PCR	P31PCR	P30PCR
Initial value	0	0	0	0	0	0	0	0
Read/Write	R/W	R/W	R/W	R/W	R/W	R/W	R/W	R/W

Port 3 Input Pull-Up Control

0	Input pull-up transistor is off.
1	Input pull-up transistor is on.

P1DDR—Port 1 Data Direction Register**H'FFB0****Port 1**

Bit	7	6	5	4	3	2	1	0
	P17DDR	P16DDR	P15DDR	P14DDR	P13DDR	P12DDR	P11DDR	P10DDR

Mode 1

Initial value	1	1	1	1	1	1	1	1
Read/Write	—	—	—	—	—	—	—	—

Modes 2 and 3

Initial value	0	0	0	0	0	0	0	0
Read/Write	W	W	W	W	W	W	W	W

Port 4 Input/Output Control

0	Input port
1	Output port

P1DR—Port 1 Data Register**H'FFB2****Port 1**

Bit	7	6	5	4	3	2	1	0
	P17	P16	P15	P14	P13	P12	P11	P10
Initial value	0	0	0	0	0	0	0	0
Read/Write	R/W	R/W	R/W	R/W	R/W	R/W	R/W	R/W

P2DDR—Port 2 Data Direction Register**H'FFB1****Port 2**

Bit	7	6	5	4	3	2	1	0
	P27DDR	P26DDR	P25DDR	P24DDR	P23DDR	P22DDR	P21DDR	P20DDR
Mode 1								
Initial value	1	1	1	1	1	1	1	1
Read/Write	—	—	—	—	—	—	—	—
Modes 2 and 3								
Initial value	0	0	0	0	0	0	0	0
Read/Write	W	W	W	W	W	W	W	W

Port 2 Input/Output Control

0	Input port
1	Output port

P2DR—Port 2 Data Register**H'FFB3****Port 2**

Bit	7	6	5	4	3	2	1	0
	P27	P26	P25	P24	P23	P22	P21	P20
Initial value	0	0	0	0	0	0	0	0
Read/Write	R/W	R/W	R/W	R/W	R/W	R/W	R/W	R/W

P3DDR—Port 3 Data Direction Register**H'FFB4****Port 3**

Bit	7	6	5	4	3	2	1	0
	P37DDR	P36DDR	P35DDR	P34DDR	P33DDR	P32DDR	P31DDR	P30DDR
Initial value	0	0	0	0	0	0	0	0
Read/Write	W	W	W	W	W	W	W	W

Port 3 Input/Output Control

0	Input port
1	Output port

P3DR—Port 3 Data Register**H'FFB6****Port 3**

Bit	7	6	5	4	3	2	1	0
	P37	P36	P35	P34	P33	P32	P31	P30
Initial value	0	0	0	0	0	0	0	0
Read/Write	R/W	R/W	R/W	R/W	R/W	R/W	R/W	R/W

P4DDR—Port 4 Data Direction Register**H'FFB5****Port 4**

Bit	7	6	5	4	3	2	1	0
	P47DDR	P46DDR	P45DDR	P44DDR	P43DDR	P42DDR	P41DDR	P40DDR
Initial value	0	0	0	0	0	0	0	0
Read/Write	W	W	W	W	W	W	W	W

Port 4 Input/Output Control

0	Input port
1	Output port

P4DR—Port 4 Data Register**H'FFB7****Port 4**

Bit	7	6	5	4	3	2	1	0
	P47	P46	P45	P44	P43	P42	P41	P40
Initial value	0	0	0	0	0	0	0	0
Read/Write	R/W	R/W	R/W	R/W	R/W	R/W	R/W	R/W

P5DDR—Port 5 Data Direction Register**H'FFB8****Port 5**

Bit	7	6	5	4	3	2	1	0
	—	—	—	—	—	P52DDR	P51DDR	P50DDR
Initial value	1	1	1	1	1	0	0	0
Read/Write	—	—	—	—	—	W	W	W

Port 5 Input/Output Control

0	Input port
1	Output port

P5DR—Port 5 Data Register**H'FFBA****Port 5**

Bit	7	6	5	4	3	2	1	0
	—	—	—	—	—	P52	P51	P50
Initial value	1	1	1	1	1	0	0	0
Read/Write	—	—	—	—	—	R/W	R/W	R/W

P6DDR—Port 6 Data Direction Register**H'FFB9****Port 6**

Bit	7	6	5	4	3	2	1	0
	P67DDR	P66DDR	P65DDR	P64DDR	P63DDR	P62DDR	P61DDR	P60DDR
Initial value	0	0	0	0	0	0	0	0
Read/Write	W	W	W	W	W	W	W	W

Port 6 Input/Output Control

0	Input port
1	Output port

P6DR—Port 6 Data Register**H'FFBB****Port 6**

Bit	7	6	5	4	3	2	1	0
	P67	P66	P65	P64	P63	P62	P61	P60
Initial value	0	0	0	0	0	0	0	0
Read/Write	R/W	R/W	R/W	R/W	R/W	R/W	R/W	R/W

P7DR—Port 7 Data Register**H'FFBE****Port 7**

Bit	7	6	5	4	3	2	1	0
	P77	P76	P75	P74	P73	P72	P71	P70
Initial value	*	*	*	*	*	*	*	*
Read/Write	R	R	R	R	R	R	R	R

Note: * Depends on the levels of pins P77 to P70.

P8DDR—Port 8 Data Direction Register**H'FFBD****Port 8**

Bit	7	6	5	4	3	2	1	0
	—	P86DDR	P85DDR	P84DDR	P83DDR	P82DDR	P81DDR	P80DDR
Initial value	1	0	0	0	0	0	0	0
Read/Write	—	W	W	W	W	W	W	W

Port 8 Input/Output Control

0	Input port
1	Output port

P8DR—Port 8 Data Register**H'FFBF****Port 8**

Bit	7	6	5	4	3	2	1	0
	—	P86	P85	P84	P83	P82	P81	P80
Initial value	1	0	0	0	0	0	0	0
Read/Write	—	R/W	R/W	R/W	R/W	R/W	R/W	R/W

P9DDR—Port 9 Data Direction Register**H'FFC0****Port 9**

Bit	7	6	5	4	3	2	1	0
	P97DDR	P96DDR	P95DDR	P94DDR	P93DDR	P92DDR	P91DDR	P90DDR
Mode 1 and 2								
Initial value	0	1	0	0	0	0	0	0
Read/Write	W	—	W	W	W	W	W	W
Mode 3								
Initial value	0	0	0	0	0	0	0	0
Read/Write	W	W	W	W	W	W	W	W

Port 9 Input/Output Control

0	Input port
1	Output port

P9DR—Port 9 Data Register

H'FFC1

Port 9

Bit	7	6	5	4	3	2	1	0
	P96	P96	P95	P94	P93	P92	P91	P90
Initial value	0	*	0	0	0	0	0	0
Read/Write	R/W	R	R/W	R/W	R/W	R/W	R/W	R/W

Notes: * Depends on the level of pin P96.

STCR—Serial/Timer Control Register

H'FFC3

TMR0/1

Bit	7	6	5	4	3	2	1	0
	—	—	—	—	—	MPE	ICKS1	ICKS0
Initial value	1	1	1	1	1	0	0	0
Read/Write	—	—	—	—	—	R/W	R/W	R/W

Multiprocessor Enable

0	Multiprocessor communication function is disabled.
1	Multiprocessor communication function is enabled.

Internal Clock Source Select

See TCR under TMR0 and TMR1.

SYSCR—System Control Register

H'FFC4

System Control

Bit	7	6	5	4	3	2	1	0
	SSBY	STS2	STS1	STS0	—	NMIEG	DPME	RAME
Initial value	0	0	0	0	1	0	0	1
Read/Write	R/W	R/W	R/W	R/W	—	R/W	R/W*	R/W

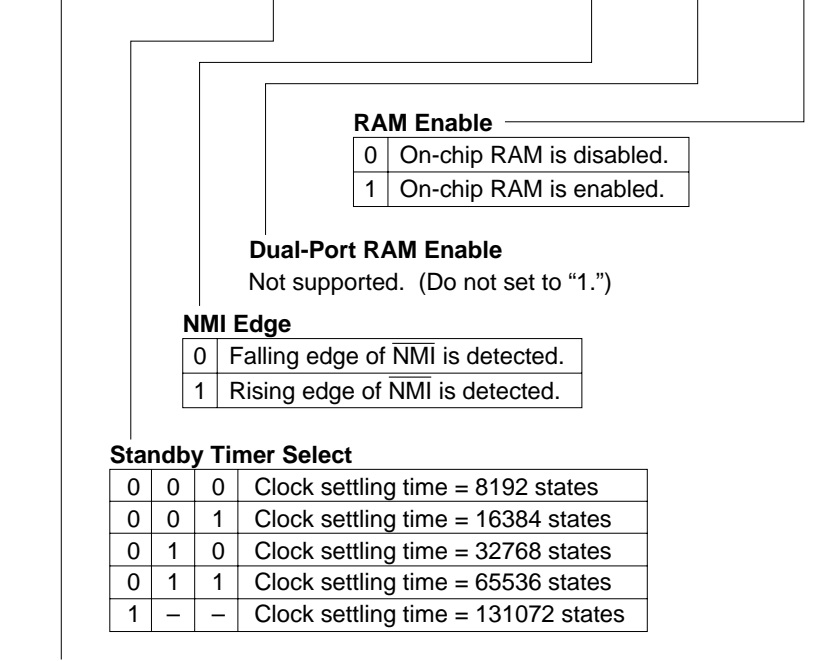

RAM Enable

0	On-chip RAM is disabled.
1	On-chip RAM is enabled.

Dual-Port RAM Enable
Not supported. (Do not set to "1.")

NMI Edge

0	Falling edge of NMI is detected.
1	Rising edge of NMI is detected.

Standby Timer Select

0	0	0	Clock settling time = 8192 states
0	0	1	Clock settling time = 16384 states
0	1	0	Clock settling time = 32768 states
0	1	1	Clock settling time = 65536 states
1	—	—	Clock settling time = 131072 states

Software Standby

0	SLEEP instruction causes transition to sleep mode.
1	SLEEP instruction causes transition to software standby mode.

Note: * Do not set DPME to 1.

MDCR—Mode Control Register**H'FFC5****System Control**

Bit	7	6	5	4	3	2	1	0
	—	—	—	—	—	—	MDS ₁	MDS ₀
Initial value	1	1	1	0	0	1	*	*
Read/Write	—	—	—	—	—	—	R/W	R/W

Mode Select Bits

Value at mode pins.

Note: * Determined by inputs at pins MD₁ and MD₀**ISCR—IRQ Sense Control Register****H'FFC6****System Control**

Bit	7	6	5	4	3	2	1	0
	IRQ ₇ SC	IRQ ₆ SC	IRQ ₅ SC	IRQ ₄ SC	IRQ ₃ SC	IRQ ₂ SC	IRQ ₁ SC	IRQ ₀ SC
Initial value	0	0	0	0	0	0	0	0
Read/Write	R/W	R/W	R/W	R/W	R/W	R/W	R/W	R/W

IRQ₀ to IRQ₇ Sense Control

0	IRQ _i is level-sensed (active low).
1	IRQ _i is edge-sensed (falling edge).

IER—IRQ Enable Register**H'FFC7****System Control**

Bit	7	6	5	4	3	2	1	0
	IRQ ₇ E	IRQ ₆ E	IRQ ₅ E	IRQ ₄ E	IRQ ₃ E	IRQ ₂ E	IRQ ₁ E	IRQ ₀ E
Initial value	0	0	0	0	0	0	0	0
Read/Write	R/W	R/W	R/W	R/W	R/W	R/W	R/W	R/W

IRQ₀ to IRQ₇ Enable

0	IRQ _i is disabled.
1	IRQ _i is enabled.

TCR—Timer Control Register

H'FFC8

TMRO

Bit	7	6	5	4	3	2	1	0
	CMIEB	CMIEA	OVIE	CCLR1	CCLR0	CKS2	CKS1	CKS0
Initial value	0	0	0	0	0	0	0	0
Read/Write	R/W	R/W	R/W	R/W	R/W	R/W	R/W	R/W

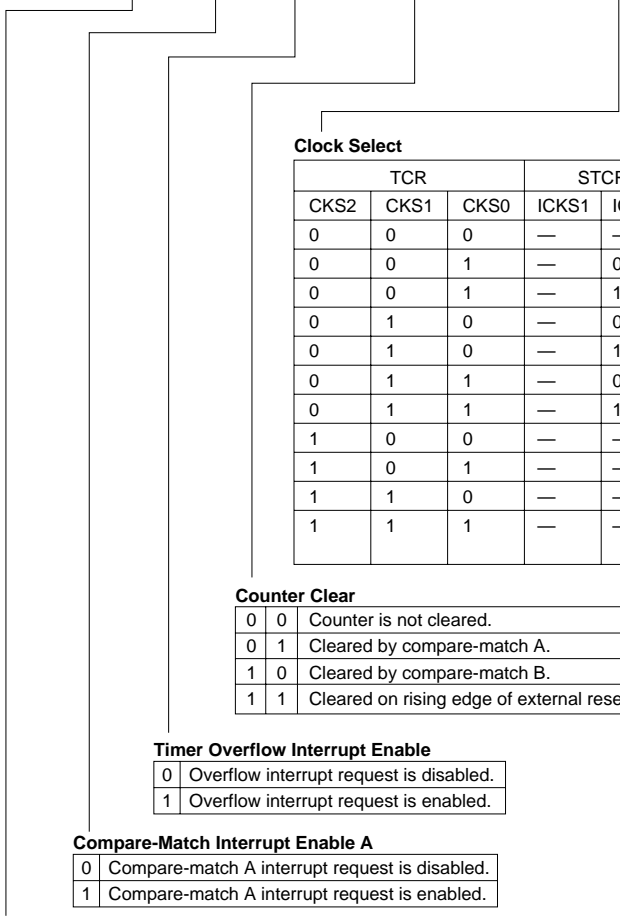

Clock Select

TCR			STCR		Description
CKS2	CKS1	CKS0	ICKS1	ICKS0	
0	0	0	—	—	Timer stopped
0	0	1	—	0	Ø/8 internal clock, falling edge
0	0	1	—	1	Ø/2 internal clock, falling edge
0	1	0	—	0	Ø/64 internal clock, falling edge
0	1	0	—	1	Ø/32 internal clock, falling edge
0	1	1	—	0	Ø/1024 internal clock, falling edge
0	1	1	—	1	Ø/256 internal clock, falling edge
1	0	0	—	—	Timer stopped
1	0	1	—	—	External clock, rising edge
1	1	0	—	—	External clock, falling edge
1	1	1	—	—	External clock, rising and falling edges

Counter Clear

0	0	Counter is not cleared.
0	1	Cleared by compare-match A.
1	0	Cleared by compare-match B.
1	1	Cleared on rising edge of external reset input.

Timer Overflow Interrupt Enable

0	Overflow interrupt request is disabled.
1	Overflow interrupt request is enabled.

Compare-Match Interrupt Enable A

0	Compare-match A interrupt request is disabled.
1	Compare-match A interrupt request is enabled.

Compare-Match Interrupt Enable B

0	Compare-match B interrupt request is disabled.
1	Compare-match B interrupt request is enabled.

Bit	7	6	5	4	3	2	1	0
	CMFB	CMFA	OVF	—	OS3*2	OS2*2	OS1*2	OS0*2
Initial value	0	0	0	1	0	0	0	0
Read/Write	R/(W)*1	R/(W)*1	R/(W)*1	—	R/W	R/W	R/W	R/W

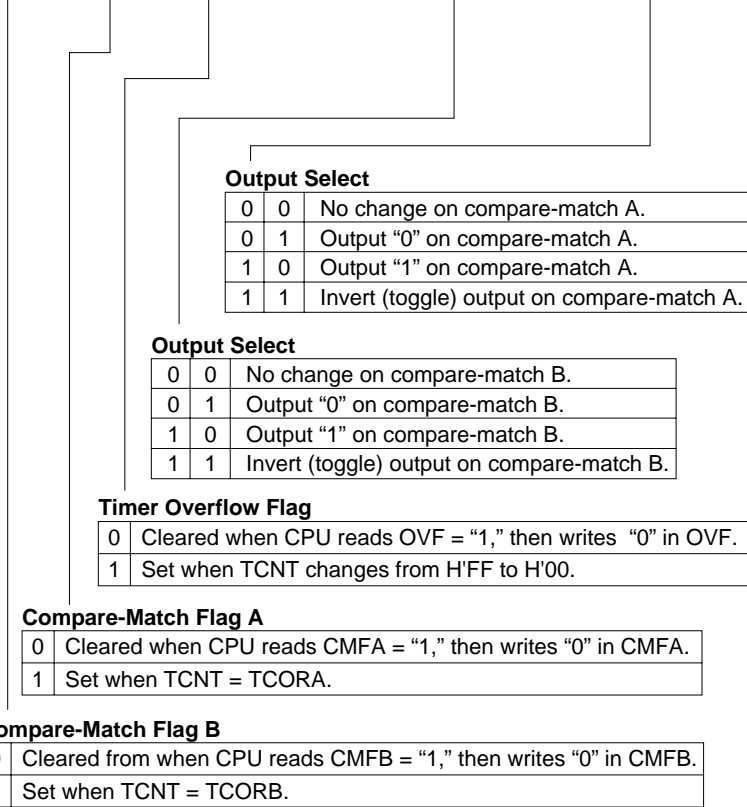

- Notes: 1. Software can write a "0" in bits 7 to 5 to clear the flags, but cannot write a "1" in these bits.
 2. When all four bits (OS3 to OS0) are cleared to "0," output is disabled.

TCORA—Time Constant Register A**H'FFCA****TMR0**

Bit	7	6	5	4	3	2	1	0
Initial value	1	1	1	1	1	1	1	1
Read/Write	R/W	R/W	R/W	R/W	R/W	R/W	R/W	R/W

The CMFA bit is set to "1" when TCORA= TCNT.

TCORB—Time Constant Register B**H'FFCB****TMR0**

Bit	7	6	5	4	3	2	1	0
Initial value	1	1	1	1	1	1	1	1
Read/Write	R/W	R/W	R/W	R/W	R/W	R/W	R/W	R/W

The CMFB bit is set to "1" when TCORB= TCNT.

TCNT—Timer Counter**H'FFCC****TMR0**

Bit	7	6	5	4	3	2	1	0
Initial value	0	0	0	0	0	0	0	0
Read/Write	R/W	R/W	R/W	R/W	R/W	R/W	R/W	R/W

Count value

TCR—Timer Control Register

H'FFD0

TMR1

Bit	7	6	5	4	3	2	1	0
	CMIEB	CMIEA	OVIE	CCLR1	CCLR0	CKS2	CKS1	CKS0
Initial value	0	0	0	0	0	0	0	0
Read/Write	R/W	R/W	R/W	R/W	R/W	R/W	R/W	R/W

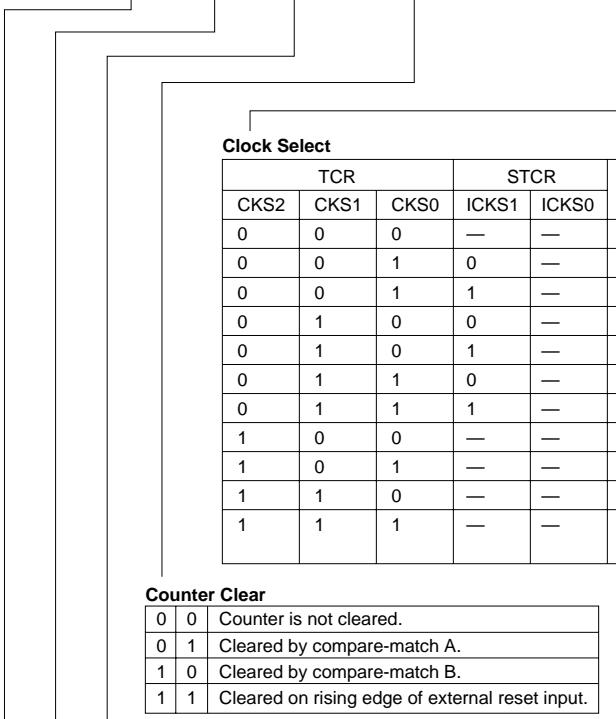

Clock Select

TCR			STCR		Description
CKS2	CKS1	CKS0	ICKS1	ICKS0	
0	0	0	—	—	Timer stopped
0	0	1	0	—	Ø/8 internal clock, falling edge
0	0	1	1	—	Ø/2 internal clock, falling edge
0	1	0	0	—	Ø/64 internal clock, falling edge
0	1	0	1	—	Ø/128 internal clock, falling edge
0	1	1	0	—	Ø/1024 internal clock, falling edge
0	1	1	1	—	Ø/2048 internal clock, falling edge
1	0	0	—	—	Timer stopped
1	0	1	—	—	External clock, rising edge
1	1	0	—	—	External clock, falling edge
1	1	1	—	—	External clock, rising and falling edges

Counter Clear

0	0	Counter is not cleared.
0	1	Cleared by compare-match A.
1	0	Cleared by compare-match B.
1	1	Cleared on rising edge of external reset input.

Timer Overflow Interrupt Enable

0	Overflow interrupt request is disabled.
1	Overflow interrupt request is enabled.

Compare-Match Interrupt Enable A

0	Compare-match A interrupt request is disabled.
1	Compare-match A interrupt request is enabled.

Compare-Match Interrupt Enable B

0	Compare-match B interrupt request is disabled.
1	Compare-match B interrupt request is enabled.

TCSR—Timer Control/Status Register**H'FFD1****TMR1**

Bit	7	6	5	4	3	2	1	0
	CMFB	CMFA	OVF	—	OS3*2	OS2*2	OS1*2	OS0*2
Initial value	0	0	0	1	0	0	0	0
Read/Write	R/(W)*1	R/(W)*1	R/(W)*1	—	R/W	R/W	R/W	R/W

Note: Bit functions are the same as for TMR0.

*1 Software can write a “0” in bits 7 to 5 to clear the flags, but cannot write a “1” in these bits.

*2 When all four bits (OS3 to OS0) are cleared to “0,” output is disabled.

TCORA—Time Constant Register A**H'FFD2****TMR1**

Bit	7	6	5	4	3	2	1	0
Initial value	1	1	1	1	1	1	1	1
Read/Write	R/W	R/W	R/W	R/W	R/W	R/W	R/W	R/W

Note: Bit functions are the same as for TMR0.

TCORB—Time Constant Register B**H'FFD3****TMR1**

Bit	7	6	5	4	3	2	1	0
Initial value	1	1	1	1	1	1	1	1
Read/Write	R/W	R/W	R/W	R/W	R/W	R/W	R/W	R/W

Note: Bit functions are the same as for TMR0.

TCNT—Timer Counter**H'FFD4****TMR1**

Bit	7	6	5	4	3	2	1	0
Initial value	0	0	0	0	0	0	0	0
Read/Write	R/W	R/W	R/W	R/W	R/W	R/W	R/W	R/W

Note: Bit functions are the same as for TMR0.

SMR—Serial Mode Register

H'FFD8

SCI0

Bit	7	6	5	4	3	2	1	0
	C/ \bar{A}	CHR	PE	O/ \bar{E}	STOP	MP	CKS1	CKS0
Initial value	0	0	0	0	0	0	0	0
Read/Write	R/W	R/W	R/W	R/W	R/W	R/W	R/W	R/W

Clock select

0	0	\emptyset clock
	1	$\emptyset/4$ clock
1	0	$\emptyset/16$ clock
	1	$\emptyset/64$ clock

Multiprocessor mode

0	Multiprocessor function disabled
1	Multiprocessor format selected

Stop bit length

0	One stop bit
1	Two stop bits

Parity mode

0	Even parity
1	Odd parity

Parity enable

0	Transmit: No parity bit added. Receive: Parity bit not checked.
1	Transmit: No parity bit added. Receive: Parity bit not checked.

Character length

0	8-bit data length
1	7-bit data length

Communication mode

0	Asynchronous
1	Synchronous

BRR—Bit Rate Register**H'FFD9****SCI0**

Bit	7	6	5	4	3	2	1	0
Initial value	1	1	1	1	1	1	1	1
Read/Write	R/W	R/W	R/W	R/W	R/W	R/W	R/W	R/W

Constant that determines the bit rate

Note: Bit functions are the same as for SCI1.

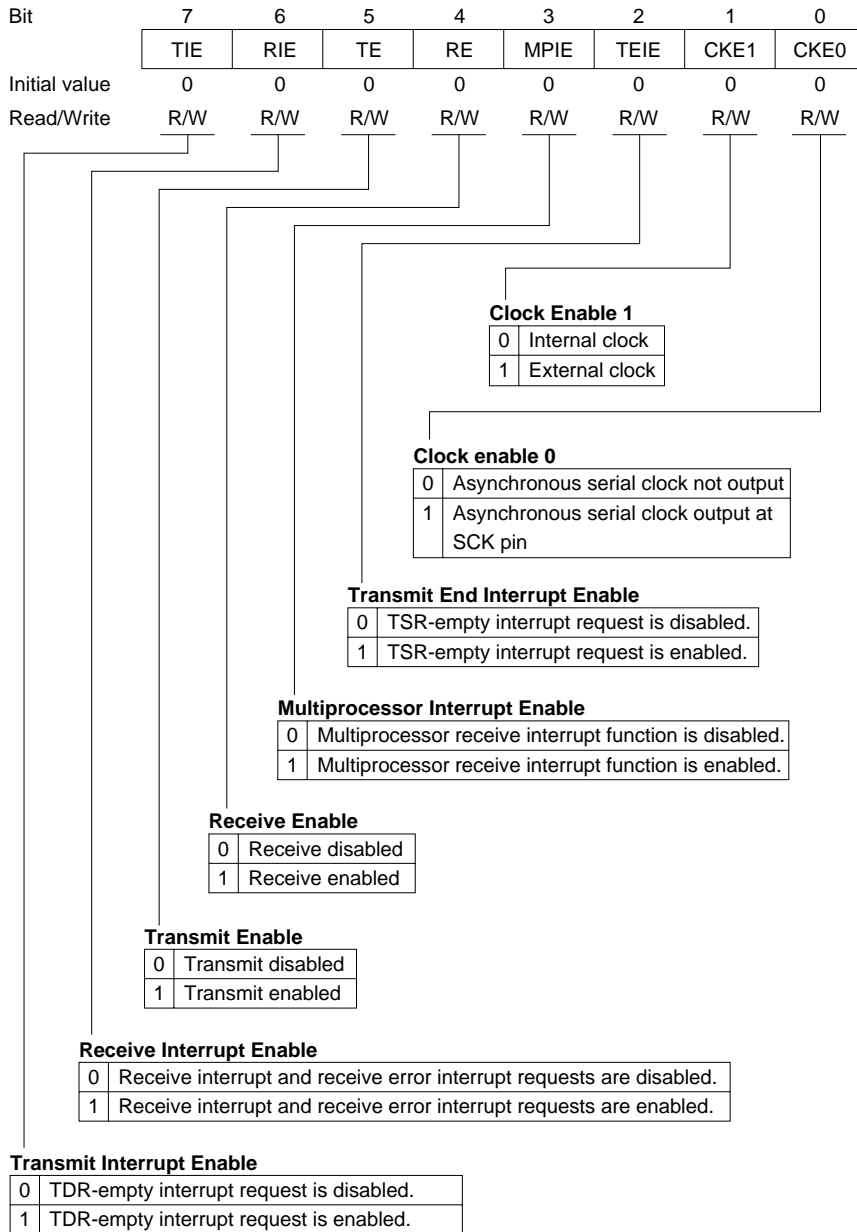

Note: Bit functions are the same as for SCI1.

TDR—Transmit Data Register

H'FFDB

SCI0

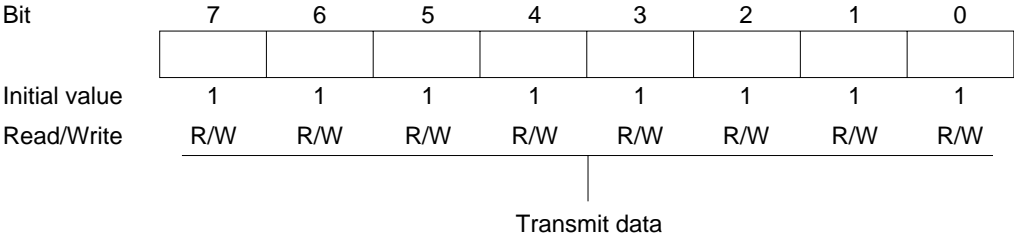

Note: Bit functions are the same as for SCI1.

Bit	7	6	5	4	3	2	1	0
	TDRE	RDRF	ORER	FER	PER	TEND	MPB	MPBT
Initial value	1	0	0	0	0	1	0	0
Read/Write	R/(W)*	R/(W)*	R/(W)*	R/(W)*	R/(W)*	R	R	R/W

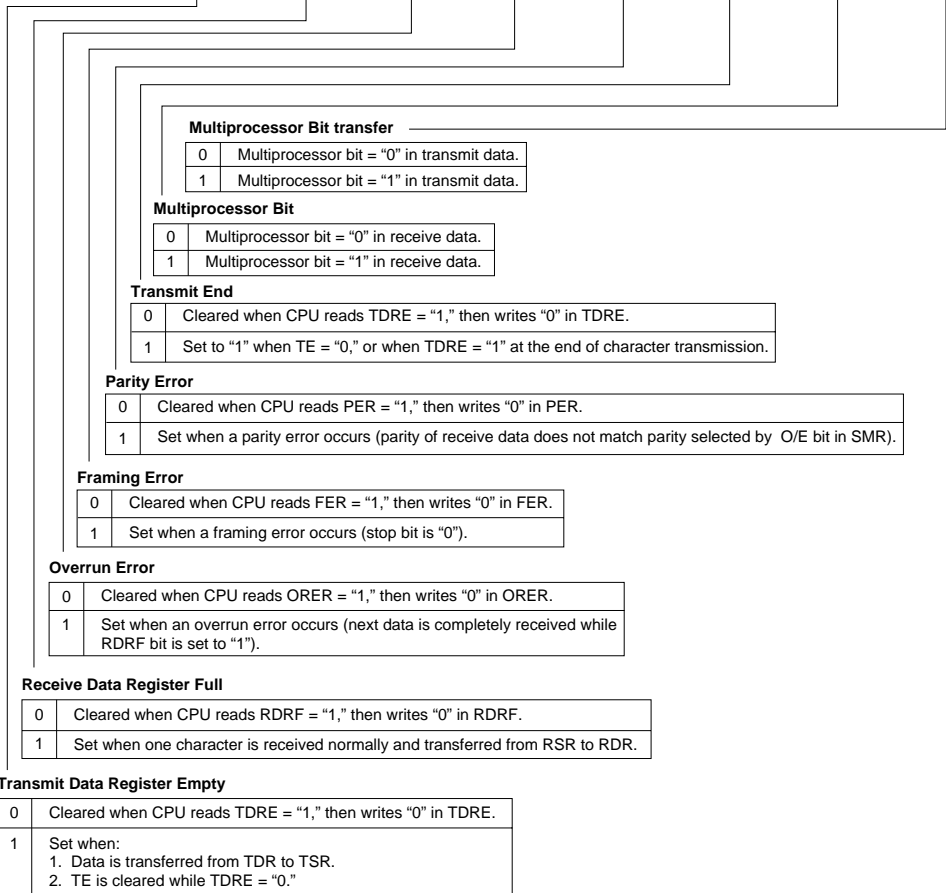

Note: Software can write a "0" in bits 7 to 3 to clear the flags, but cannot write a "1" in these bits. Bit functions are the same as for SCI1.

RDR—Receive Data Register**H'FFDD****SCI0**

Bit	7	6	5	4	3	2	1	0
Initial value	0	0	0	0	0	0	0	0
Read/Write	R	R	R	R	R	R	R	R

|
Receive data

Note: Bit functions are the same as for SCI1.

ADDRn—A/D Data Register n (n = A, B, C, D)**H'FFE0, H'FFE2,
H'FFE4, H'FFE6****A/D**

Bit	7	6	5	4	3	2	1	0
Initial value	0	0	0	0	0	0	0	0
Read/Write	R	R	R	R	R	R	R	R

|
A/D conversion result

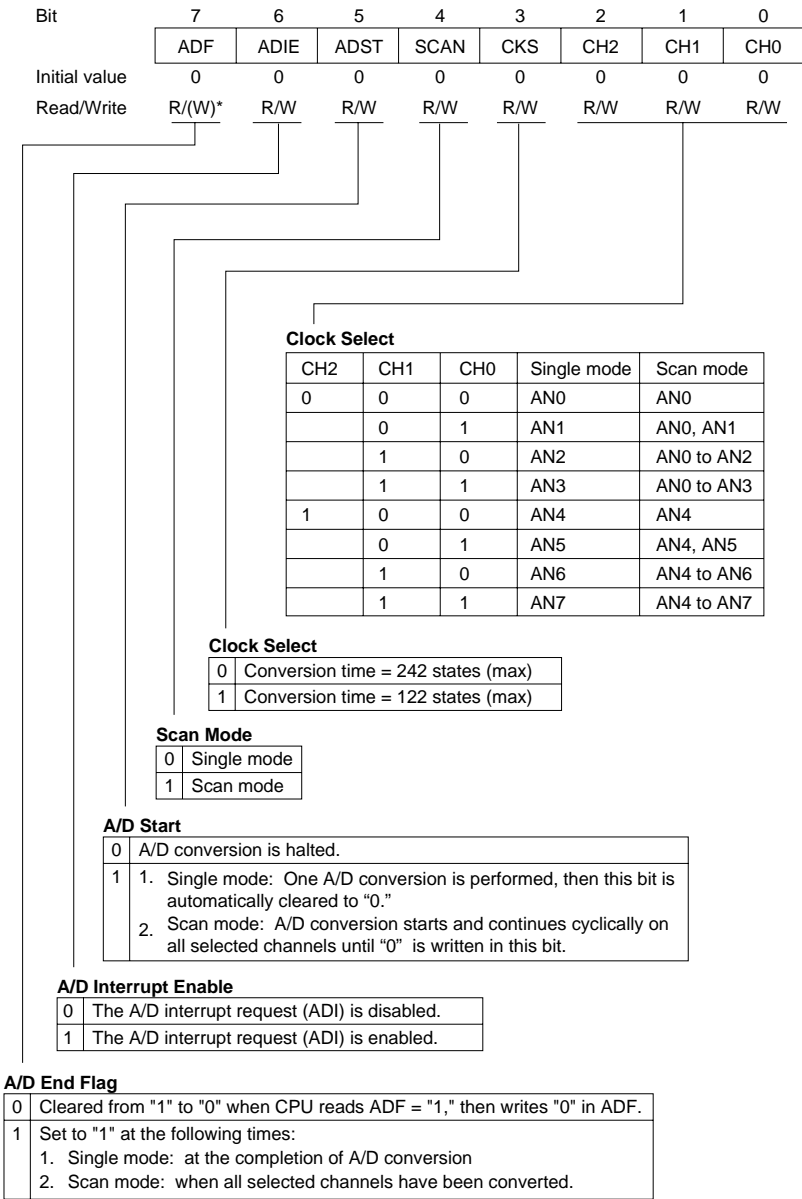

Note: Software can write a "0" in bit 7 to clear the flag, but cannot write a "1" in this bit.

ADCR—A/D Control Register

H'FFEA

A/D

Bit	7	6	5	4	3	2	1	0
	TRGE	—	—	—	—	—	—	CHS
Initial value	0	1	1	1	1	1	1	0
Read/Write	R/W	—	—	—	—	—	—	R/W

Reserved bit.

Trigger Enable

0	ADTRG is disabled.
1	ADTRG is enabled. A/D conversion can be started by external trigger, or by software.

Appendix C Pin States

C.1 Pin States in Each Mode

Table C.1 Pin States

Pin Name	MCU Mode	Reset	Hardware Standby	Software Standby	Sleep Mode	Normal Operation
P17 – P10 A7 – A0	1	Low	3-State	Low	(Addr. output pins: last address accessed)	A7 – A0
	2	3-State		Low if DDR = 1, Prev. state if DDR = 0		Addr. output or input port
	3			Prev. state		I/O port
P27 – P20 A15 – A8	1	Low	3-State	Low	(Addr. output pins: last address accessed)	A15 – A8
	2	3-State		Low if DDR = 1, Prev. state if DDR = 0		Addr. output or input port
	3			Prev. state		I/O port
P37 – P30 D7 – D0	1	3-State	3-State	3-state	3-State	D7 – D0
	2					
	3			Prev. state	Prev. state	I/O port
P47 – P40	1	3-State	3-State	Prev. state*	Prev. state	I/O port
	2					
	3					
P52 – P50	1	3-State	3-State	Prev. state*	Prev. state	I/O port
	2					
	3					

Notes: 1. 3-State: High-impedance state

2. Prev. state: Previous state. Input ports are in the high-impedance state (with the MOS pull-up on if PCR = 1). Output ports hold their previous output level.

3. I/O port: Direction depends on the data direction (DDR) bit. Note that these pins may also be used by the on-chip supporting modules. See section 5, "I/O Ports," for further information.

* On-chip supporting modules are initialized, so these pins revert to I/O ports according to the DDR and DR bits.

Table C.1 Pin States (cont)

Pin Name	MCU Mode	Reset	Hardware Standby	Software Standby	Sleep Mode	Normal Operation
P67 – P60	1	3-State	3-State	Prev. state*	Prev. state	I/O port
	2					
	3					
P77 – P70	1	3-State	3-State	3-State	3-State	Input port
	2					
	3					
P86 – P80	1	3-State	3-State	Prev. state*	Prev. state	I/O port
	2					
	3					
P97/ $\overline{\text{WAIT}}$	1	3-State	3-State	3-State	3-State	$\overline{\text{WAIT}}$
	2					
	3			Prev. state	Prev. state	I/O port
P96/ ϕ	1	Clock output	3-State	High	Clock output	Clock output
	2					
	3	3-State		High if DDR = 1, 3-state if DDR = 0	Clock output if DDR = 1, 3-state if DDR = 0	Clock output if DDR = 1, input port if DDR = 0
P95 – P93, $\overline{\text{AS}}, \overline{\text{WR}}, \overline{\text{RD}}$	1	High	3-State	High	High	$\overline{\text{AS}}, \overline{\text{WR}}, \overline{\text{RD}}$
	2					
	3	3-State		Prev. state	Prev. state	I/O port
P92 – P90	1	3-State	3-State	Prev. state	Prev. state	I/O port
	2					
	3					

Notes: 1. 3-State: High-impedance state

2. Prev. state: Previous state. Input ports are in the high-impedance state (with the MOS pull-up on if PCR = 1). Output ports hold their previous output level.

3. I/O port: Direction depends on the data direction (DDR) bit. Note that these pins may also be used by the on-chip supporting modules.

See section 5, "I/O Ports," for further information.

* On-chip supporting modules are initialized, so these pins revert to I/O ports according to the DDR and DR bits.

Appendix D Timing of Transition to and Recovery from Hardware Standby Mode

Timing of Transition to Hardware Standby Mode

- (1) To retain RAM contents when the RAME bit in SYSCR is cleared to 0, drive the RES signal low 10 system clock cycles before the STBY signal goes low, as shown below. RES must remain low until STBY goes low (minimum delay from STBY low to RES high: 0 ns).

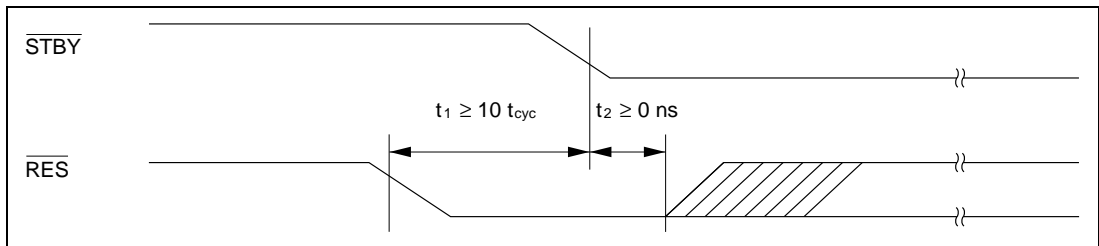

- (2) When the RAME bit in SYSCR is set to “1” or when it is not necessary to retain RAM contents, RES does not have to be driven low as in (1).

Timing of Recovery From Hardware Standby Mode: Drive the RES signal low approximately 100 ns before STBY goes high.

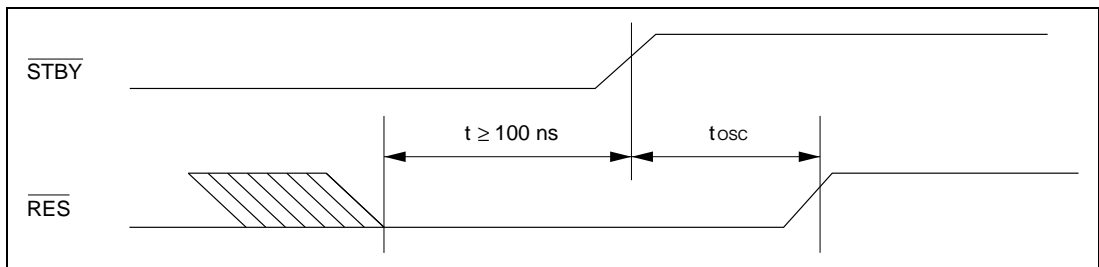

Appendix E Package Dimensions

Figure E.1 shows the dimensions of the CG-84 package. Figure E.2 shows the dimensions of the CP-84 package. Figure E.3 shows the dimensions of the FP-80A package.

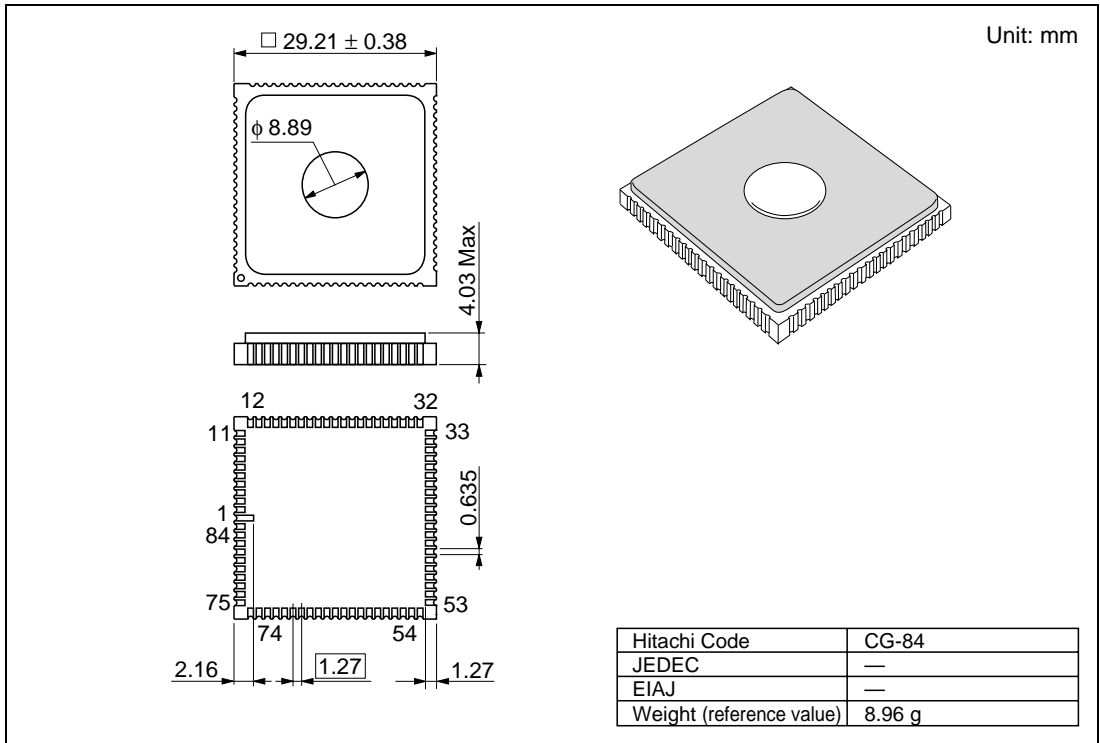
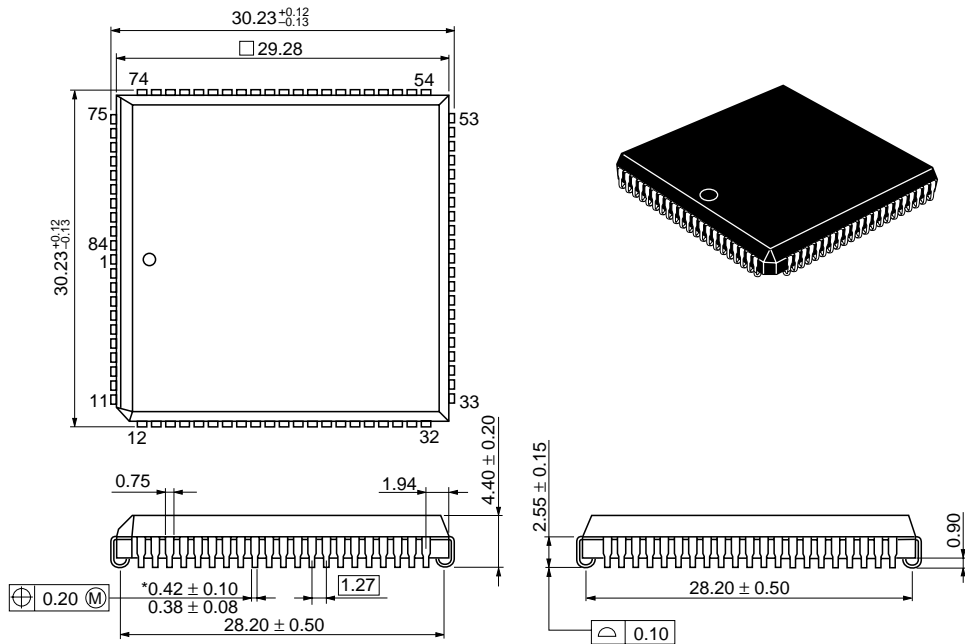

Figure E.1 Package Dimensions (CG-84)

Unit: mm



*Dimension including the plating thickness
Base material dimension

Hitachi Code	CP-84
JEDEC	Conforms
EIAJ	Conforms
Weight (reference value)	6.4 g

Figure E.2 Package Dimensions (CP-84)

H8/338 Series Hardware Manual

Publication Date: 1st Edition, July 1992

3rd Edition, September 1998

Published by: Electronic Devices Sales & Marketing Group
Semiconductor & Integrated Circuits
Hitachi, Ltd.

Edited by: Technical Documentation Group
UL Media Co., Ltd.

Copyright © Hitachi, Ltd., 1992. All rights reserved. Printed in Japan.

Filename: COLOPHON.DOC
Directory: C:\WINNT\Profiles\aschwerm.001\Desktop\H33TH025D1
Template: C:\Program Files\Microsoft Office\Templates\UMTMP5C.DOT
Title: SuperH' (SH) 32-bit RISC MCU/MPU Series
Subject:
Author: M. Toyohashi
Keywords:
Comments:
Creation Date: 07/03/98 10:10 AM
Change Number: 10
Last Saved On: 06/17/99 4:34 PM
Last Saved By: kashi
Total Editing Time: 11 Minutes
Last Printed On: 01/10/00 1:10 PM
As of Last Complete Printing
Number of Pages: 1
Number of Words: 8 (approx.)
Number of Characters: 46 (approx.)