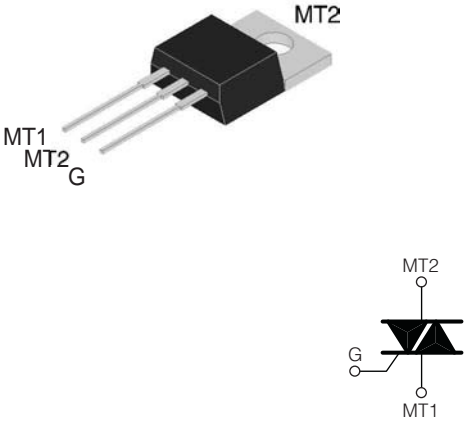

LOGIC LEVEL TRIAC

<p style="text-align: center;">TO-220AB</p>  <p>The image shows a physical TO-220AB TRIAC component with three leads labeled MT1, MT2, and G. Below it is a schematic symbol for a TRIAC with terminals labeled MT2, G, and MT1.</p>	<table border="0" style="width: 100%;"> <tr> <td style="text-align: center;">On-State Current</td> <td style="text-align: center;">Gate Trigger Current</td> </tr> <tr> <td style="text-align: center;">6 Amp</td> <td style="text-align: center;">< 10 mA</td> </tr> <tr> <td colspan="2" style="text-align: center;">Off-State Voltage</td> </tr> <tr> <td colspan="2" style="text-align: center;">200 V ÷ 800 V</td> </tr> </table> <p>This series of TRIACs uses a high performance PNPN technology.</p> <p>These parts are intended for general purpose AC switching applications with highly inductive loads.</p>	On-State Current	Gate Trigger Current	6 Amp	< 10 mA	Off-State Voltage		200 V ÷ 800 V	
On-State Current	Gate Trigger Current								
6 Amp	< 10 mA								
Off-State Voltage									
200 V ÷ 800 V									

Absolute Maximum Ratings, according to IEC publication No. 134

SYMBOL	PARAMETER	CONDITIONS	Value	Unit
$I_{T(RMS)}$	RMS On-state Current (full sine wave)	All Conduction Angle, $T_C = 95\text{ }^\circ\text{C}$	6	A
I_{TSM}	Non-repetitive On-State Current	Full Cycle, 60 Hz ($t = 16.7\text{ ms}$)	66	A
I_{TSM}	Non-repetitive On-State Current	Full Cycle, 50 Hz ($t = 20\text{ ms}$)	60	A
I^2t	Fusing Current	$t_p = 10\text{ ms}$, Half Cycle	18	A ² s
I_{GM}	Peak Gate Current	$20\text{ }\mu\text{s max.}$ $T_j = 125\text{ }^\circ\text{C}$	4	A
$P_{G(AV)}$	Average Gate Power Dissipation	$T_j = 125\text{ }^\circ\text{C}$	1	W
di/dt	Critical rate of rise of on-state current	$I_G = 2x I_{GT}$, $t_r \leq 100\text{ ns}$ $f = 120\text{ Hz}$, $T_j = 125\text{ }^\circ\text{C}$	50	A/ μs
T_j	Operating Temperature		(-40 + 125)	$^\circ\text{C}$
T_{stg}	Storage Temperature		(-40 + 150)	$^\circ\text{C}$
T_{sld}	Soldering Temperature	10s max	260	$^\circ\text{C}$

SYMBOL	PARAMETER	VOLTAGE					Unit
		B	D	M	S	N	
V_{DRM} V_{RRM}	Repetitive Peak Off State Voltage	200	400	600	700	800	V

LOGIC LEVEL TRIAC
Electrical Characteristics

SYMBOL	PARAMETER	CONDITIONS	Quadrant		SENSITIVITY		Unit
					07	08	
I _{GT} ⁽¹⁾	Gate Trigger Current	V _D = 12 V _{DC} , R _L = 33Ω, T _j = 25 °C	Q1÷Q3	MAX	5	10	mA
			Q4	MAX	7		mA
V _{GT}	Gate Trigger Voltage	V _D = 12 V _{DC} , R _L = 33Ω, T _j = 25 °C	Q1÷Q3	MAX	1.3		V
			Q1÷Q4	MAX	1.3		V
V _{GD}	Gate Non Trigger Voltage	V _D = V _{DRM} , R _L = 3.3 KΩ, T _j = 125 °C	Q1÷Q3	MIN	0.2		V
			Q1÷Q4	MIN	0.2		V
I _H ⁽²⁾	Holding Current	I _T = 100 mA, Gate open, T _j = 25 °C		MAX	15	15	mA
I _L	Latching Current	I _G = 1.2 I _{GT} , T _j = 25 °C	Q1,Q3	MAX		25	mA
			Q1,Q3,Q4	MAX	20		mA
			Q2	MAX	30	30	mA
dV/dt ⁽²⁾	Critical Rate of Voltage Rise	V _D = 0.67 x V _{DRM} , Gate open T _j = 125 °C		MIN	20	40	V/μs
(dI/dt) ⁽²⁾	Critical Rate of Current Rise	(dv/dt) _c = 0.1 V/μs T _j = 125 °C (dv/dt) _c = 10 V/μs T _j = 125 °C without snubber T _j = 125 °C		MIN	2.7	3.5	A/ms
				MIN	1.2	2.4	A/ms
				MIN	-	-	
V _{TM} ⁽²⁾	On-state Voltage	I _T = 7.5 Amp, tp = 380 μs, T _j = 25 °C		MAX	1.6		V
V _{t(o)} ⁽²⁾	Threshold Voltage	T _j = 125 °C		MAX	0.85		V
r _d ⁽²⁾	Dynamic resistance	T _j = 125 °C		MAX	60		mΩ
I _{DRM} /I _{RRM}	Off-State Leakage Current	V _D = V _{DRM} , T _j = 125 °C		MAX	1		mA
		V _R = V _{RRM} , T _j = 25 °C		MAX	5		μA
R _{th(j-c)}	Thermal Resistance Junction-Case	for AC 360° conduction angle			1.8		°C/W
R _{th(j-a)}	Thermal Resistance Junction-Ambient	S = 1 cm ²			60		°C/W

(1) Minimum I_{GT} is guaranteed at 5% of I_{GT} max.

(2) For either polarity of electrode MT2 voltage with reference to electrode MT1.

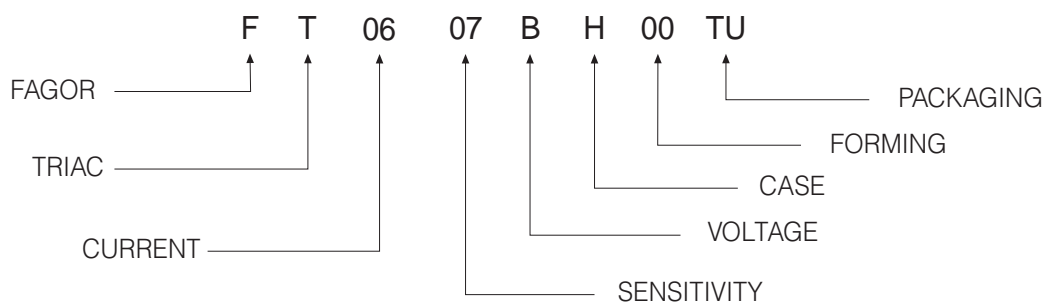
PART NUMBER INFORMATION

LOGIC LEVEL TRIAC

Fig. 1: Maximum power dissipation versus RMS on-state current (full cycle).

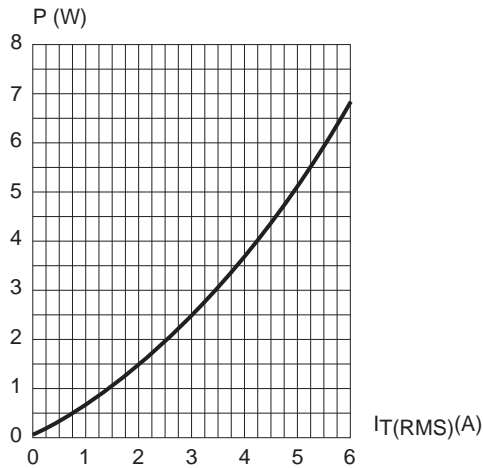

Fig. 2: RMS on-state current versus case temperature (full cycle).

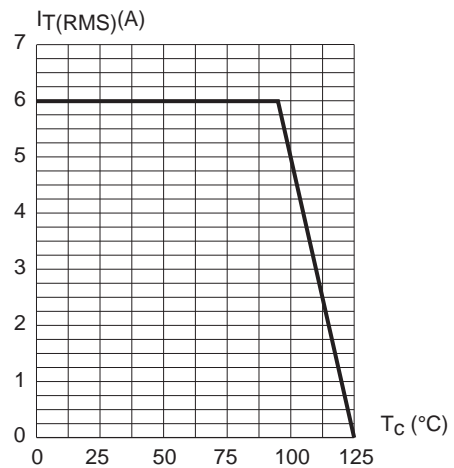

Fig. 3: Relative variation of thermal impedance versus pulse duration.

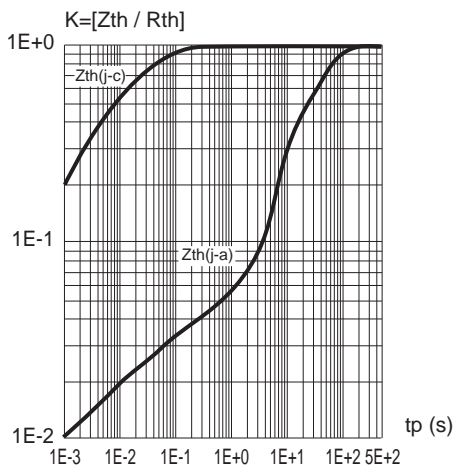

Fig. 4: On-state characteristics (maximum values)

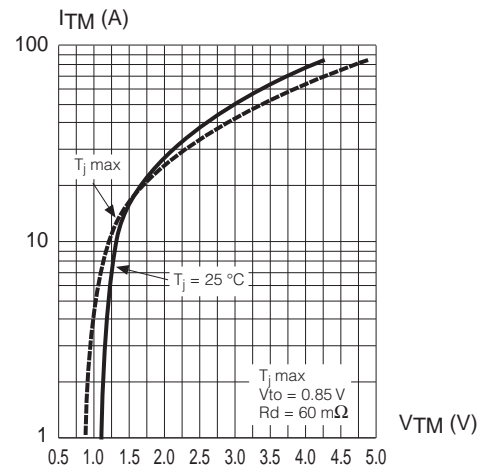

Fig. 5: Surge peak on-state current versus number of cycles

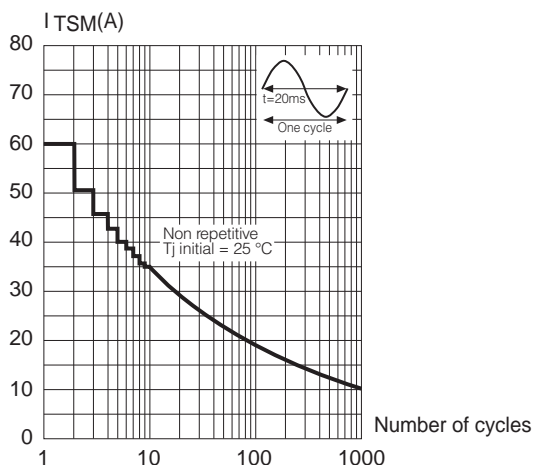
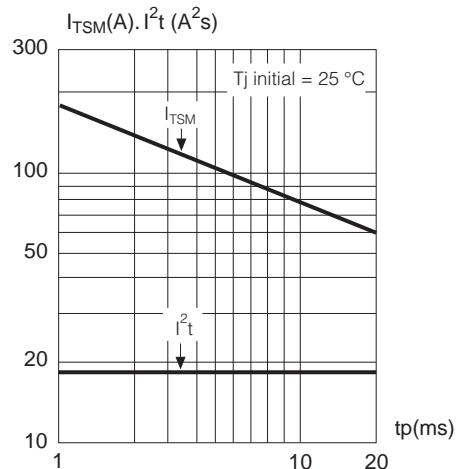

Fig. 6: Non repetitive surge peak on-state current for a sinusoidal pulse with width: $t_p < 10 \text{ ms}$, and corresponding value of I^2t .



LOGIC LEVEL TRIAC

Fig. 7: Relative variation of gate trigger current, holding current and latching versus junction temperature (typical values)

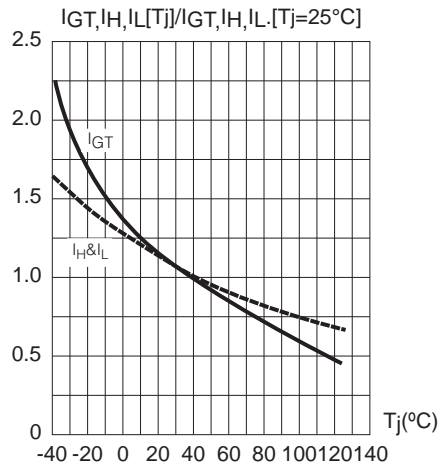

Fig. 8: Relative variation of critical rate of decrease of main current versus junction temperature

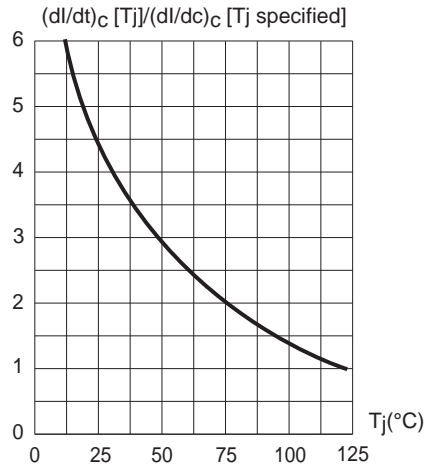
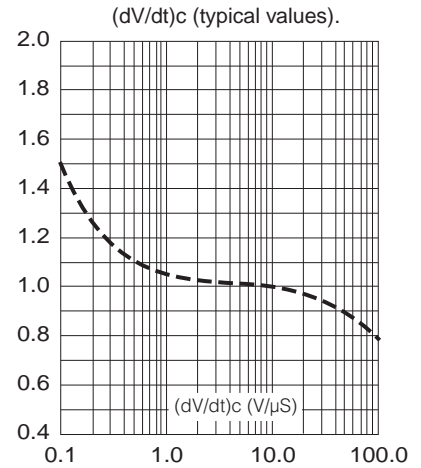
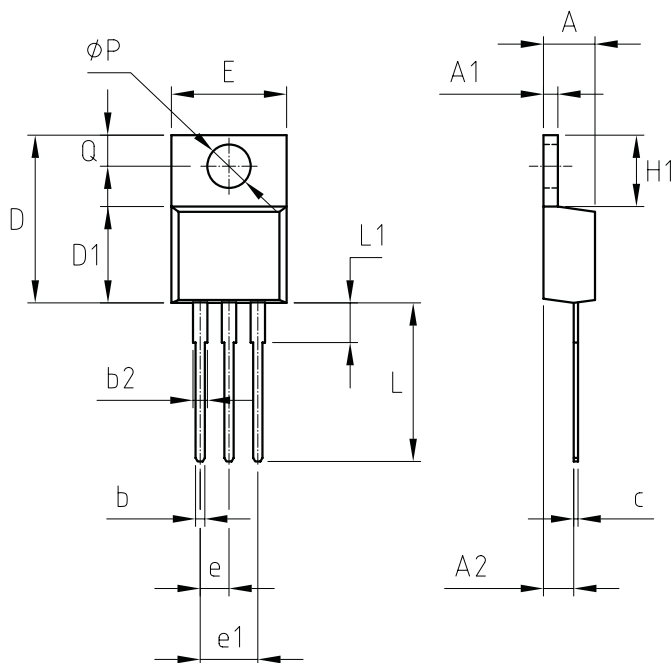

Fig. 9: Relative variation of critical rate of decrease of main current versus



PACKAGE MECHANICAL DATA

TO-220AB



REF.	DIMENSIONS	
	Millimeters	
	Min.	Max.
A	3.56	4.83
A1	0.50	1.40
A2	2.00	2.92
b	0.38	1.02
b2	1.14	1.78
c	0.31	0.61
D	14.22	16.51
D1	8.38	9.02
E	9.65	10.67
e	2.49	2.59
e1	5.03	5.18
H1	5.84	6.86
L	12.70	14.74
L1		6.35
P	3.53	4.09
Q	2.54	3.43

Mounting Torque

1 N.m

(*) Limiting values and life support applications, see Web page.