

TOSHIBA BiCD Integrated Circuit Silicon Monolithic

# TB67H302HG

## Dual Bridge Driver IC for DC motor

The TB67H302HG is a dual bridge driver IC for DC motor adopting DMOS in output transistor.

High-power and high-efficient drive is possible by adopting DMOS output driver with low-ON resistance and PWM drive.

### Features

- Dual bridge driver IC for DC motor
- $R_{on}$  (upper + lower) = 0.4 $\Omega$  (typ.)
- CW/CCW/Short brake/Stop functions
- Standby function
- PWM control (Direct PWM or Constant-current PWM drive)
- Output withstand voltage:  $V_{cc} = 50$  V
- Output current :  $I_{OUT} = 5.0$  A (Absolute maximum ratings, peak)  
 $I_{OUT} = 4.5$  A (Operating range, maximum value)
- Package : HZIP25-P-1.00F
- Built-in input pull-down resistance : 100 k $\Omega$  (typ.)
- Output monitor pin (monitor for TSD/ISD) : ALERT1 pin ( $I_{ALERT1}$  (max) = 1 mA)
- Output monitor pin (monitor for UVLO) : ALERT2 pin ( $I_{ALERT2}$  (max) = 1 mA)
- Single power supply
- Built-in thermal shutdown (TSD) circuit
- Built-in under voltage lock out (UVLO) circuit
- Built-in over-current detection (ISD) circuit

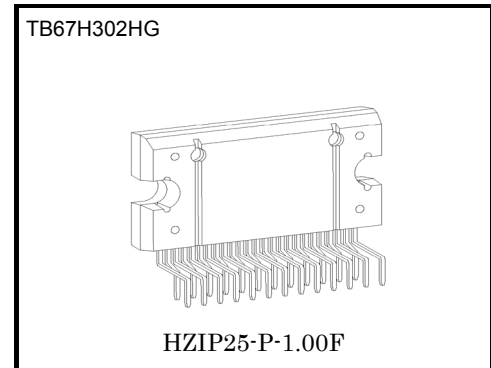

Weight  
HZIP25-P-1.00F: 7.7g (typ.)

## Pin Functions

Pin No.	I/O	Symbol	Functional Description	Remark
1	Output	ALERT1	TSD / ISD monitor pin	Pull-up by external resistance
2	—	SGND	Signal ground	
3	Input	SELECT	Select pin for constant-current PWM or direct PWM	
4	Input	VrefA	Voltage input for 100% current level for Ach	
5	Input	VrefB	Voltage input for 100% current level for Bch	
6	Input	Vcc	Power supply	
7	Input	STBY	Standby pin	H; Start, L; Standby
8	Input	IN1B	Control input pin 1 for Bch	
9	Input	IN2B	Control input pin 2 for Bch	
10	Output	OUT2B	Bch output 2	
11	—	RSB	Bch output current detection	
12	Output	OUT1B	Bch output 1	
13	—	PGNDB	Power GND	
14	Output	OUT2A	Ach output 2	
15	—	RSA	Ach output current detection	
16	Output	OUT1A	Ach output 1	
17	—	PGNDA	Power GND	
18	Input	IN1A	Control input pin 1 for Ach	
19	Input	IN2A	Control input pin 2 for Ach	
20	Input	Vcc	Power supply	
21	Input	PWMA	PWM signal input pin for Ach	
22	Input	PWMB	PWM signal input pin for Bch	
23	—	OSC	Resistor connection pin for internal oscillation setting	
24	Output	Vreg	Control side connection pin for power capacitor	Connecting capacitor to SGND
25	Output	ALERT2	UVLO monitor pin	Pull-up by external resistance

### <Terminal circuits>

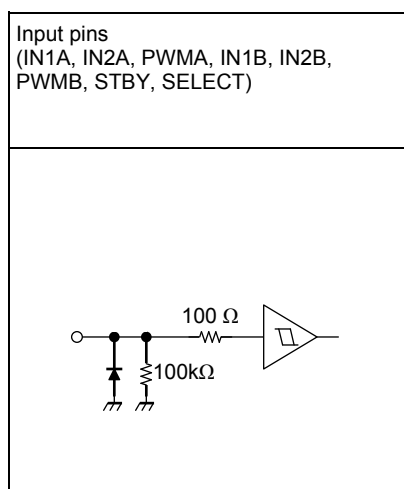

## Block Diagram

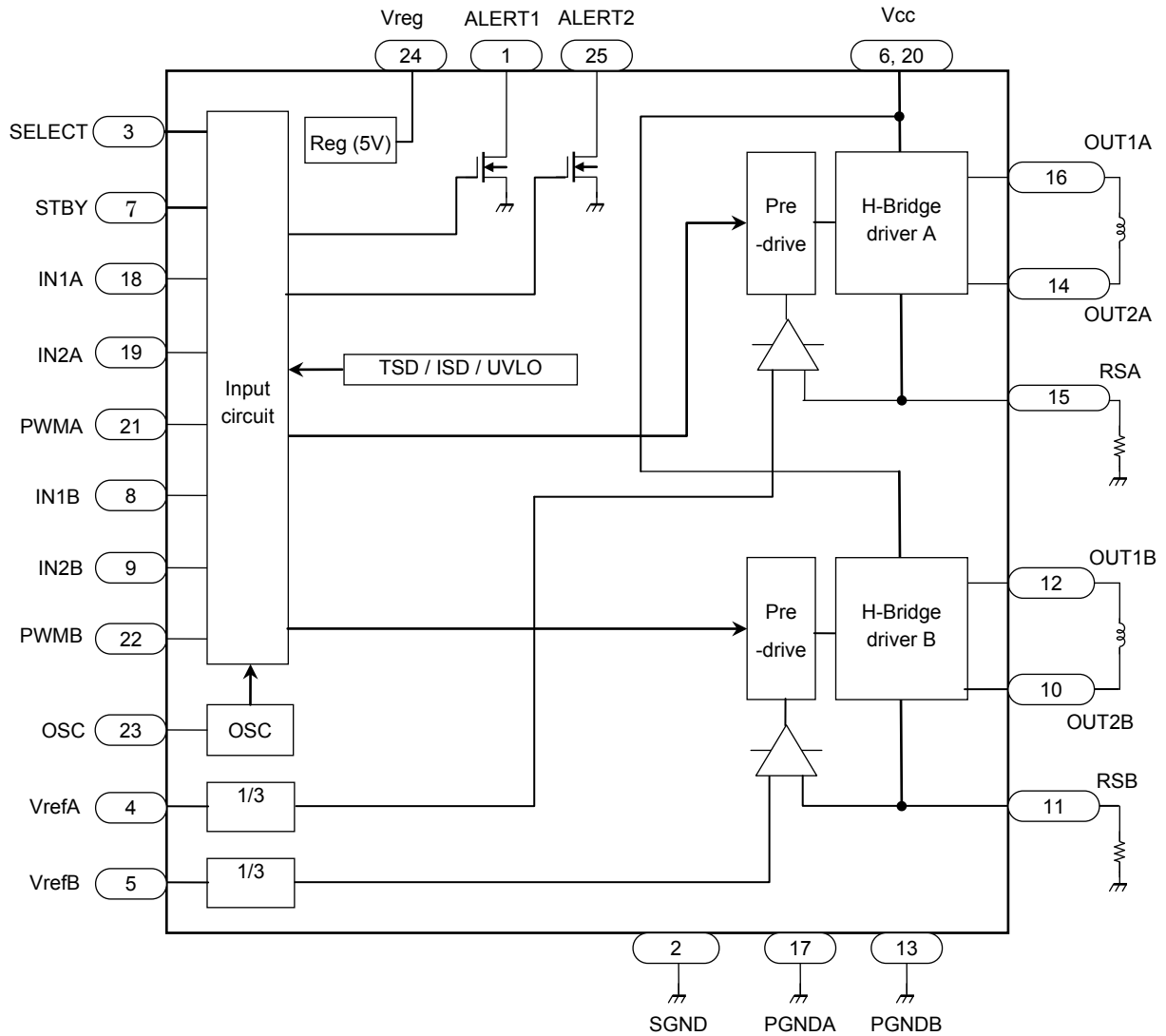

## Functions

### I/O functions

#### SELECT = L (Direct PWM mode)

Input				Output		
SB	IN1	IN2	PWM	OUT1	OUT2	Mode
H	H	H	H	L	L	Short brake
			L			
H	L	H	H	L	H	CW/CCW
			L	L	L	Short brake
H	H	L	H	H	L	CCW/CW
			L	L	L	Short brake
H	L	L	H	OFF (Hi-Z)		Stop
			L			
L	H/L	H/L	H	OFF (Hi-Z)		Standby
			L			

#### SELECT = H (Constant-current PWM mode)

Input				Output		
SB	IN1	IN2	PWM	OUT1	OUT2	Mode
H	H	H	H	L	L	Short brake
			L			
H	L	H	H	L	H	Constant-current PWM, CW (OUT2→OUT1)
			L	L	L	Short brake
H	H	L	H	H	L	Constant-current PWM, CCW (OUT1→OUT2)
			L	L	L	Short brake
H	L	L	H	OFF (Hi-Z)		Stop
			L			
L	H/L	H/L	H	OFF (Hi-Z)		Standby
			L			

## Selection of direct PWM and constant-current PWM

SELECT = L: operating direct PWM, SELECT = H: operating constant-current PWM

(1) In case of direct PWM:

- RSA should be connected to PGNDA.
- RSB should be connected to PGNDB.
- Vref A and Vref B should be connected to SGND.

(2) In case of constant-current PWM:

- RSA and RSB should be connected to current detection resistance (RNFA and RNFB) each.
- Configuration of output current is as follows;
 

Ach	Io =	$(1/3 \times VrefA) \div RNFA$
Bch	Io =	$(1/3 \times VrefB) \div RNFB$

This system adopts peak current detection. Average current is lower than setting current.

Set RNFA, RNFB, VrefA and VrefB as follows:

$0.11\Omega \leq RNFA \leq 0.5\Omega$ ,  $0.11\Omega \leq RNFB \leq 0.5\Omega$ ,  $0.3V \leq VrefA \leq 1.95V$  and  $0.3V \leq VrefB \leq 1.95V$

Triangle wave is generated internally by CR oscillation by connecting external resistor to OSC terminal.

Rosc should be from 30kΩ to 120kΩ. The relation of Rosc and fchop is shown in below table and figure. The values of fchop of the below table are design guarantee values. They are not tested for pre-shipment.

Rosc(kΩ)	fchop(kHz)		
	Min	Typ.	Max
30	-	60	-
51	-	40	-
120	-	20	-

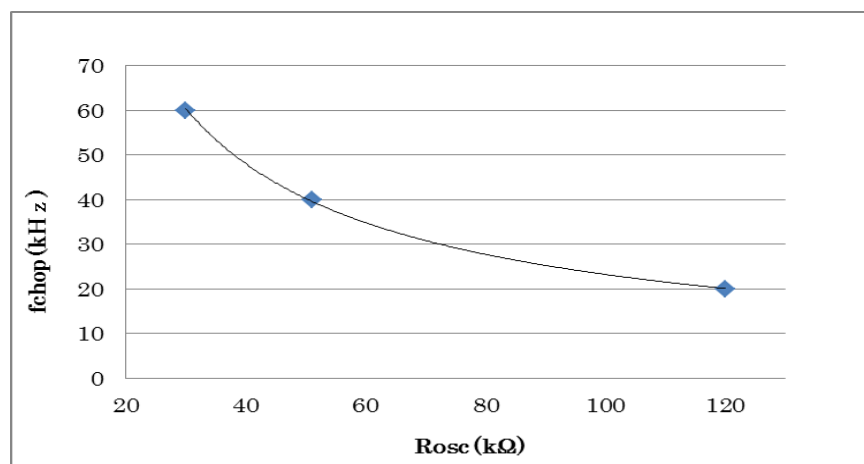

## Direct PWM Control

The motor rotation speed is controllable by the PWM input sent through the PWM pin.

It is also possible to control the motor rotation speed by sending in the PWM signal through not the PWM pin but the IN1 and IN2 pins.

When the motor drive is controlled by the PWM input, the TB67H302HG repeats operating in Normal Operation mode and Short Brake mode alternately.

For preventing the shoot-through current in the output circuit caused by the upper and lower power transistors being turned on simultaneously, the dead time is internally generated at the time the upper and lower power transistors switches between on and off.

This eliminates the need of inserting Off time externally; thus the PWM control with synchronous rectification is enabled.

Note that inserting Off time externally is not required on operation mode changes between CW and CCW, CW and Short Brake, and CW and Short Brake because of the dead time generated internally.

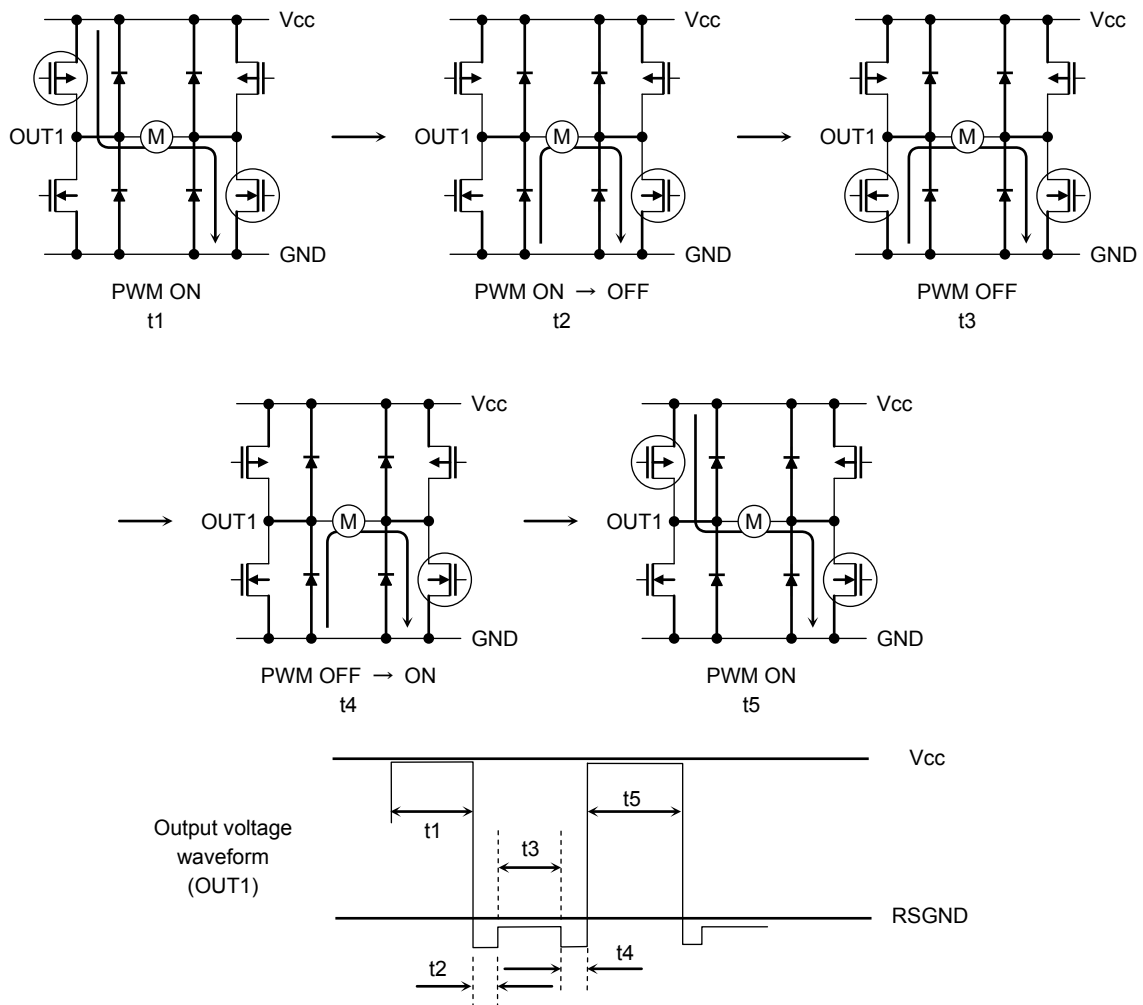

## Constant-current PWM control

Constant-current PWM control mode is set when SELECT=H.

The TB67H302HG uses a peak current detection technique to keep the output current constant by applying constant voltage through the Vref pin.

The ratio 40% of the fast decay mode is always fixed.

Charge-discharge cycles of PWM drive corresponds to 5 cycles of OSCM. The current is decreasing in the last two OSC cycles; the fast decay mode.

The relation between the master clock frequency (fMCLK), the OSCM frequency (fOSCM) and the PWM frequency (fchop) is shown as follows:

$$f_{OSCM} = 1/20 \times f_{MCLK}$$

$$f_{chop} = 1/100 \times f_{MCLK}$$

When Rosc=51kΩ, the master clock=4MHz, OSCM=200kHz, the frequency of PWM(fchop)=40kHz.

NF: Point where output current reaches the setting current.

MDT in the below figure indicates the point of MIXED DECAY TIMMING.

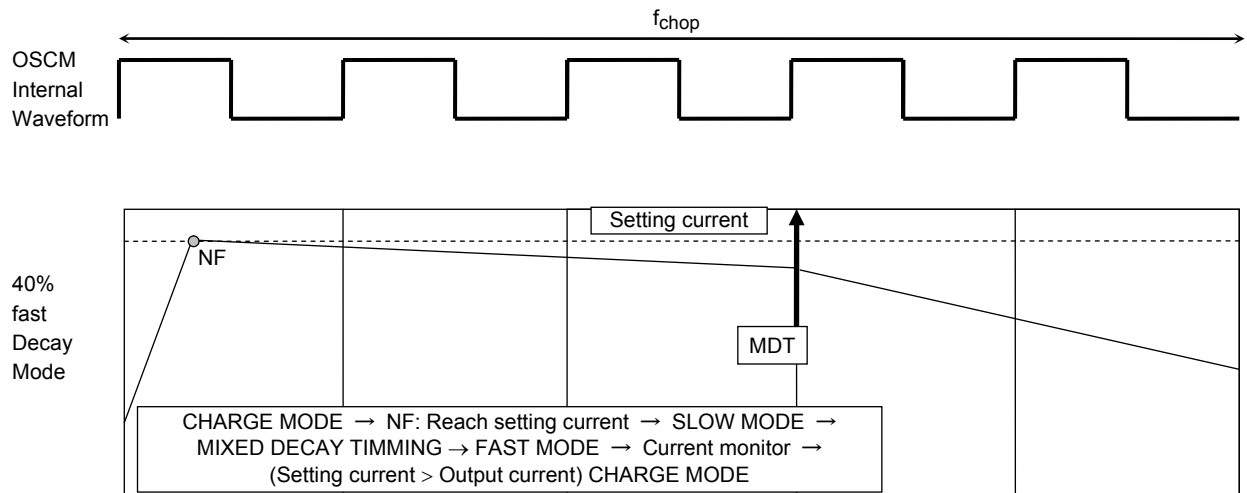

**Current waveform when setting current is changed by changing Vref in the constant-current PWM control mode**

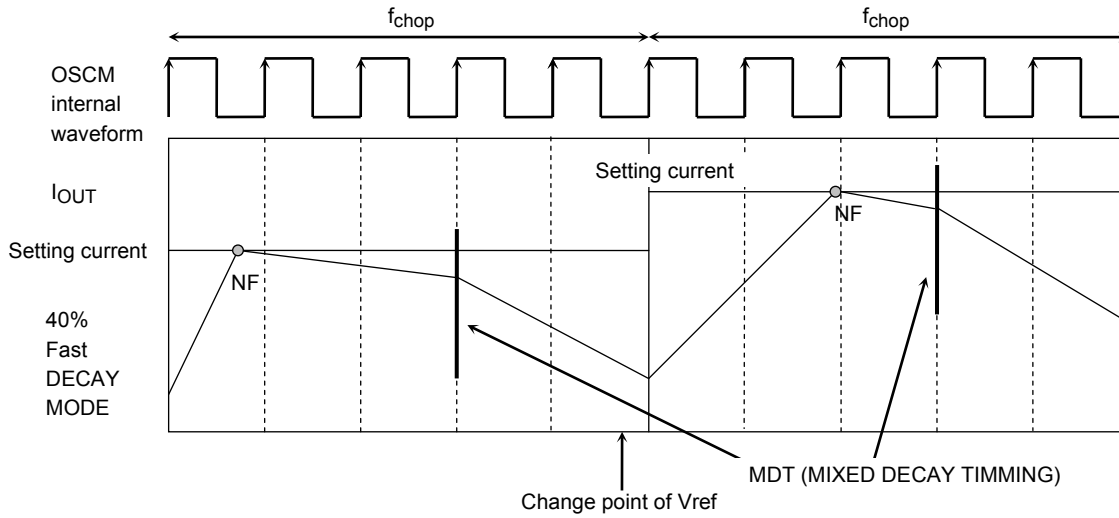

- MIXED DECAY TIMMING  $\Rightarrow$  NF point

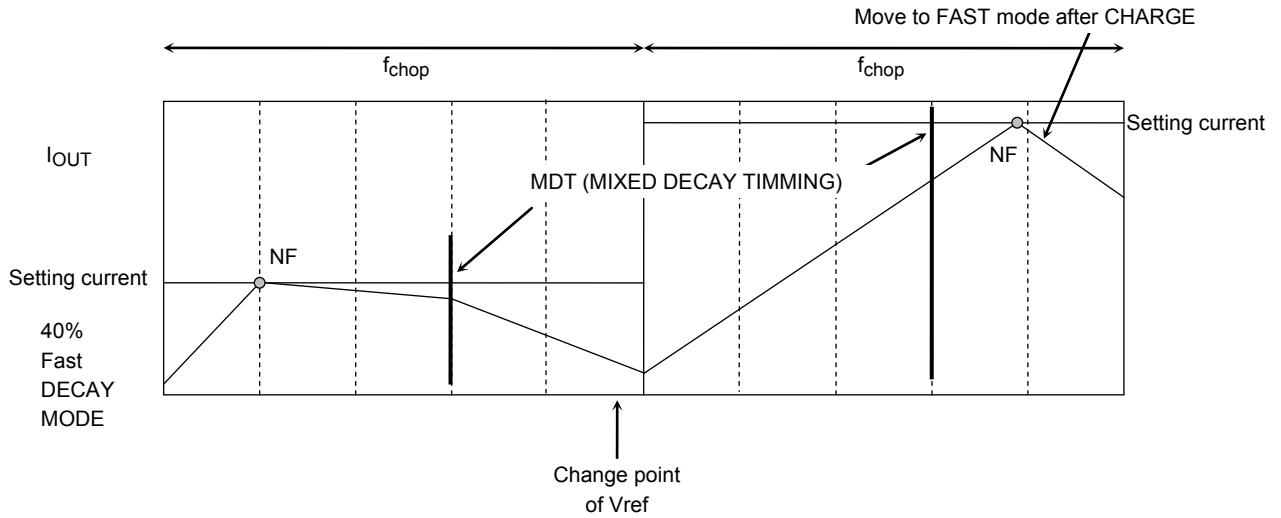

- Output current of MIXED DECAY MODE > Setting current

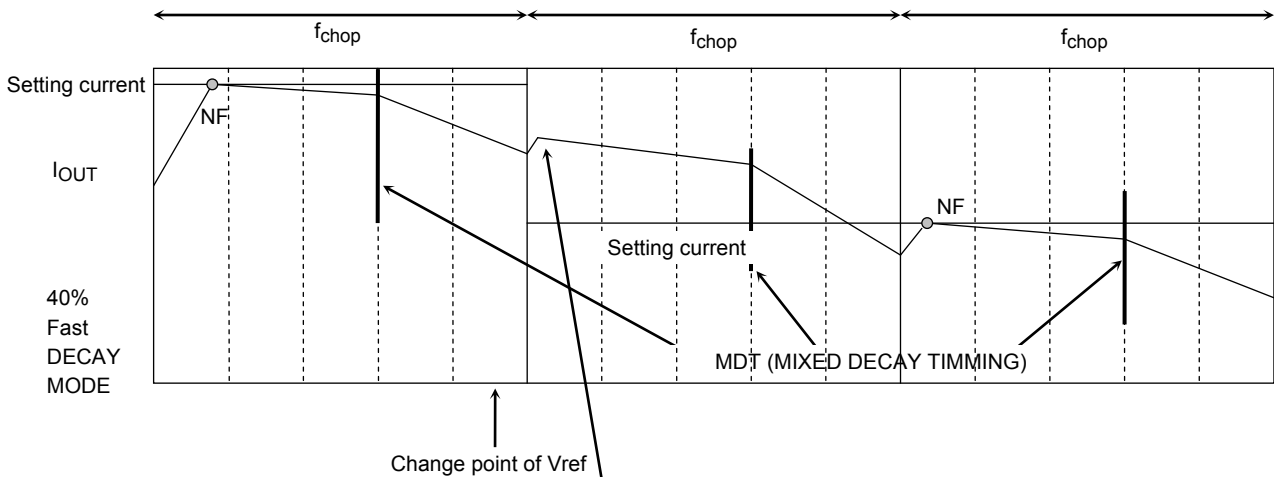

It is charged instantaneously to confirm the current though output current is larger than setting current.



## Thermal Shut-Down circuit (TSD)

**Latch return** TSD = 160°C (typ.) (Note)

(1) When recovery signal is outputted after the temperature falls lower than recovery temperature (90°C (typ.) in the below figure (Note)).

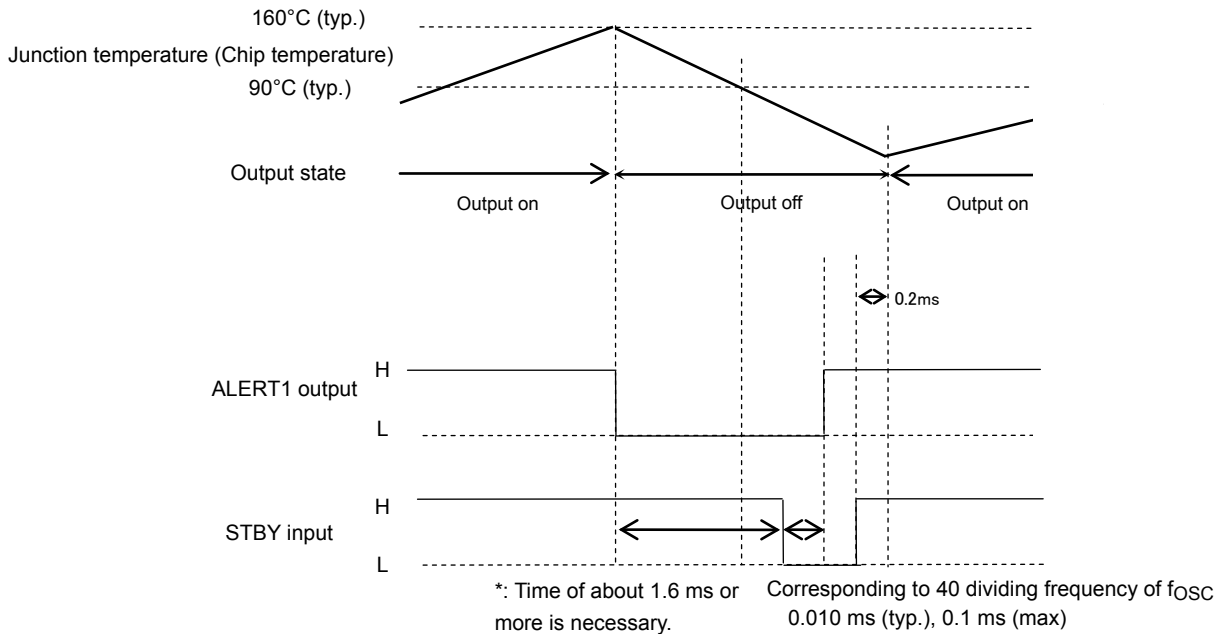

The operation returns by programming the STBY as H → L → H shown in above figure or turning on power supply and turning on UVLO function.

(2) When recovery signal is outputted before the temperature falls lower than the recovery temperature (90°C (typ.) in below figure (Note)).

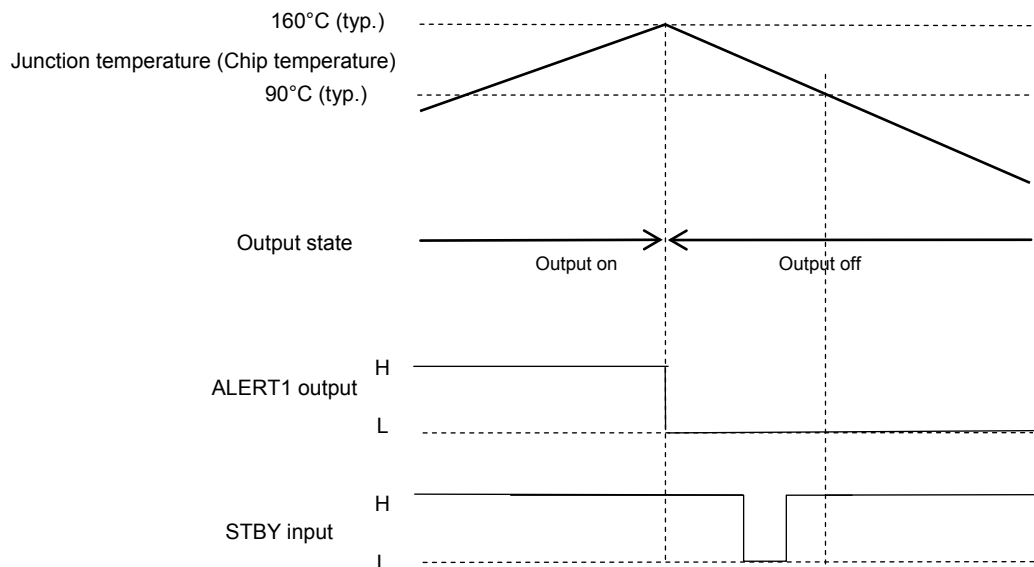

If STBY is programmed H → L → H shown in the above figure before the temperature falls lower than the recovery temperature (90°C (typ.) in the above figure (Note)), the operation does not return.

Note: Pre-shipment testing is not performed.

**STBY = L: TSD is not enabled.**

**ISD (Over current detection)**

Current that flows through output power MOSFETs are monitored individually. If over-current is detected in at least one of the eight output power MOSFETs, all output power MOSFETs are turned off. Masking term of 1μs or more (typ. when  $R_{osc}=51k\Omega$ ) (Note) should be provided in order to protect detection error by noise. ISD does not work during the masking term. The operation is not returned automatically. It is latched. This function is released by programming STBY H→L→H.

ISD = 6.5 A(typ.) (Note)

**Latch return**

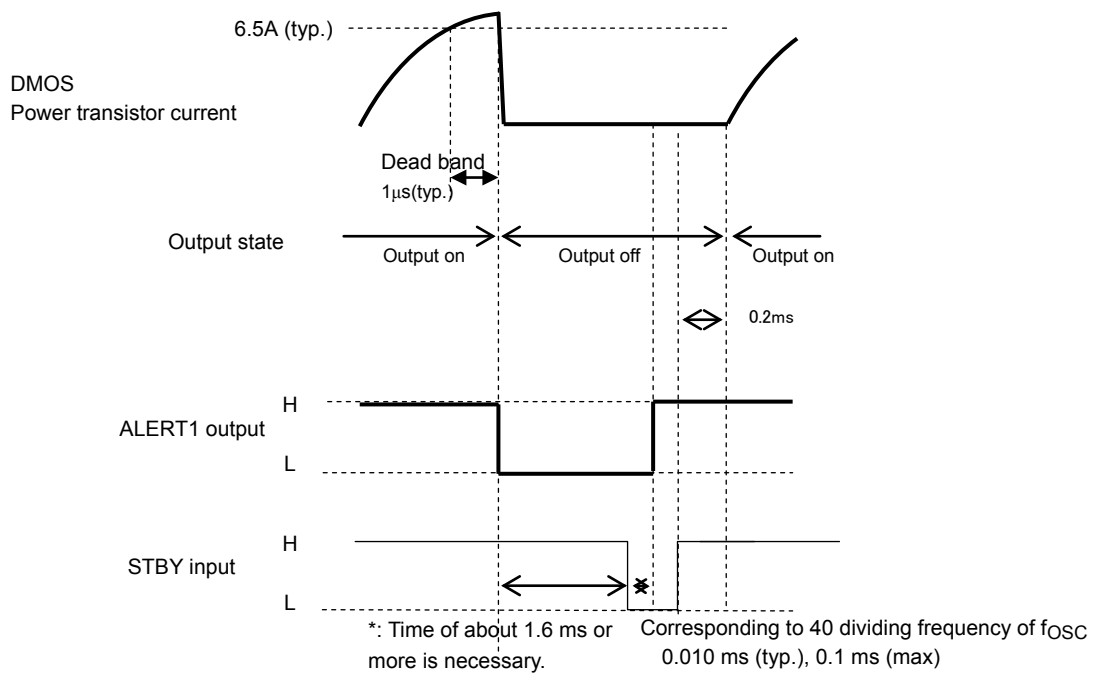

The operation returns by programming STBY H→L→H shown in the above figure or powering on the supply again to drive UVLO.

**STBY = L: ISD is not enabled.**

Note: Pre-shipment testing is not performed.

**ALERT output**

**(1) ALERT 1 (Pin No. 1)**

ALERT 1 terminal outputs in detecting either TSD or ISD.

ALERT 1 terminal is connected to power supply externally via pull-up resistance. Spec. is shown below.

$$V_{ALERT1} = 0.5V \text{ (max) at } 1mA$$

TSD	ISD	ALERT 1 terminal
Under TSD detection	Under ISD detection	Low
Normal	Under ISD detection	
Under TSD detection	Normal	
Normal	Normal	Z

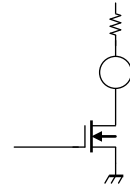

Applied voltage to pull-up resistance is up to 5.5 V. And conducted current is up to 1 mA.

The voltage of 5 V is recommended to be provided by connecting the external pull-up resistance to Vreg pin.

**(2) ALERT 2 (Pin No. 25)**

ALERT 2 terminal outputs in detecting UVLO.

ALERT 2 terminal is connected to power supply externally via pull-up resistance. Spec. is shown below.

$$V_{ALERT2} = 0.5V \text{ (max) at } 1mA$$

UVLO	ALERT 2 terminal
Under UVLO detection	Low
Normal	Z

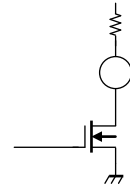

When Vcc falls to 6.0V (typ.) and UVLO is enabled, output turns off and ALERT 2 outputs low. In case Vcc falls below 6.0V (typ.), ALERT 2 outputs Hi-Z (High impedance).

The operation returns from Standby mode when Vcc rises 6.5V (typ.) or more.

Applied voltage to pull-up resistance is up to 5.5 V. And conducted current is up to 1 mA.

The voltage of 5 V is recommended to be provided by connecting the external pull-up resistance to Vreg pin.

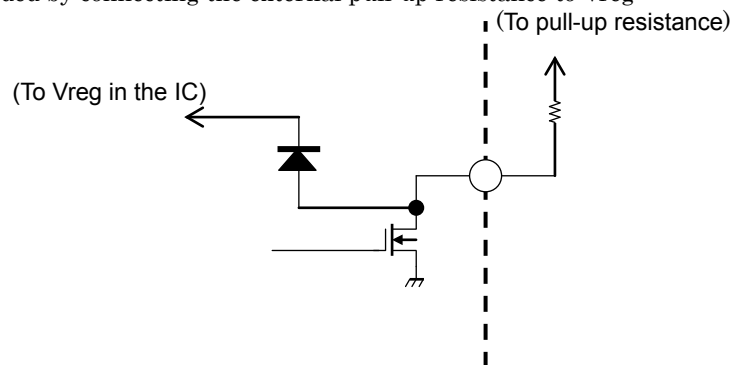

**Voltage pull-up of ALERT 1 and ALERT 2 pins**

- It is recommended to pull-up the voltage to Vreg pin.
  - In case of pulling up the voltage of except 5 V (for instance, 3.3 V etc.), it is recommended to use other power supply (ex. 3.3 V) while Vcc outputs within the operation range. When Vcc decreases lower than the operation range and Vreg decreases from 5 V to 0 V under the condition that other power supply is used to pull-up voltage, the current continues to conduct from other power supply to the IC inside through the diode shown in the figure. Though this phenomenon does not cause destruction and malfunction of the IC, please consider the set design not to continue such a state for a long time.
  - As for the pull-up resistance for ALERT1 and ALERT2 pins, please select large resistance enough for the conducting current so as not to exceed the standard value of 1 mA.
- Please use the resistance of 30 kΩ or more in case of applying 5 V, and 20 kΩ or more in case of applying 3.3 V.

## Absolute Maximum Ratings (Ta = 25°C)

Characteristic	Symbol	Rating	Unit
Power supply voltage	V <sub>CC</sub>	50	V
Output current(per 1 channel)	I <sub>O</sub> (PEAK)	5.0	A
Drain current (ALERT1, ALERT2)	I (ALERT1)	1	mA
	I (ALERT2)		
Input voltage	V <sub>IN</sub>	6	V
Power dissipation	P <sub>D</sub>	3.2 (Note 1)	W
		40 (Note 2)	
Operating temperature	T <sub>opr</sub>	-30 to 85	°C
Storage temperature	T <sub>stg</sub>	-55 to 150	°C

Note 1: Ta = 25°C, No heat sink

Note 2: Ta = 25°C, with infinite heat sink

The absolute maximum ratings of a semiconductor device are a set of ratings that must not be exceeded, even for a moment. Do not exceed any of these absolute maximum ratings.

Exceeding the absolute maximum ratings may cause the device breakdown, damage or deterioration, and may result injury by explosion or combustion.

Please use the IC within the specified operating ranges.

## Operating Range (Ta = -30 to 85°C)

Characteristic	Symbol	Test Condition	Min	Typ.	Max	Unit
Power supply voltage	V <sub>CC</sub>	—	8.0	—	42	V
Output current	I <sub>OUT</sub>	—	—	—	4.5	A
Input voltage	V <sub>IN</sub>	—	0	—	5.5	V
	V <sub>ref</sub>	—	0.3	—	1.95	V
PWM frequency (Input in direct PWM drive)	f <sub>PWM</sub>	duty50% IN1A, IN2A, PWMA, IN1B, IN2B, PWMB	—	—	100	kHz
Chopping frequency	f <sub>chop</sub>	In constant-current PWM mode Refer to page 5.	20	40	60	kHz

Note: Same voltage should be applied to two V<sub>CC</sub> pins.

The maximum current of the operating range can not be necessarily conducted depending on various conditions because output current is limited by the power dissipation P<sub>D</sub>.

Make sure to avoid using the IC in the condition that would cause the temperature to exceed T<sub>j</sub> (avg.) = 107°C.

The power supply voltage of 42 V and the output current of 4.5 A are the upper limits of the operating range. Therefore, make sure to have enough margins within these operating ranges (derating design) by considering the power supply variation, the external resistance, and the electrical characteristics of the IC. If either of the voltage or current exceeds the upper limits of the operating range, the IC may not operate normally.

## Electrical Characteristics (Ta = 25°C, Vcc = 24V)

Characteristic		Symbol	Test Condition	Min	Typ.	Max	Unit
Input voltage	High	$V_{IN(H)}$	IN1, IN2, PWM, STBY, SELECT	2.0	—	5.5	V
	Low	$V_{IN(L)}$		-0.2	—	0.8	
Input hysteresis voltage		$V_H$		—	400	—	mV
Input current		$I_{IN(H)}$	$V_{IN} = 5.0\text{ V}$	—	50	75	$\mu\text{A}$
		$I_{IN(L)}$	$V_{IN} = 0\text{ V}$	—	—	1	
Vcc supply current		$I_{CC1}$	Stop mode	—	3.2	7	mA
		$I_{CC2}$	CW/CCW mode	—	3.2	7	
		$I_{CC3}$	Short brake mode	—	3.2	7	
		$I_{CC4}$	Standby mode	—	1.9	4	
Vref input circuit	Current limit voltage	$V_{NF}$	$V_{ref} = 3.0\text{V}$ (Note 1)	0.9	1.0	1.1	V
	Input current	$I_{IN(Vref)}$	$V_{ref} = 3.0\text{V}$ (Note 1)	—	—	1	$\mu\text{A}$
	Divider ratio	$V_{ref}/V_{NF}$	Maximum current: 100%	—	3	—	—
Minimum pulse width		$t_{WPWMH}$	IN1, IN2, PWM	5.0	—	—	$\mu\text{s}$
		$t_{WPWML}$					
Output residual voltage in logic part		$V_{OL\ ALERT1}$	$I_{OL} = 1\text{ mA}$	—	—	0.5	V
		$V_{OL\ ALERT2}$					
Internal constant voltage		$V_{reg}$	Standby mode, External capacitor $C = 0.1\mu\text{F}$	4.5	5.0	5.5	V
Chopping frequency (Constant-current PWM)		$f_{chop}$	$R_{osc} = 51\text{k}\Omega$	28	40	52	kHz

Note 1: Though Vref of the test condition for pre-shipment is 3.0V, make sure to configure Vref within the operating range which is written in page 12 in driving the motor.

## Electrical Characteristics (Ta = 25°C, Vcc = 24V)

Characteristic		Symbol	Test Condition	Min	Typ.	Max	Unit
OUT pin	Output ON resistor	$R_{on\ U} + R_{on\ L}$	$I_{OUT} = 4\text{ A}$	—	0.4	0.6	$\Omega$
Output transistor switching characteristics		$t_r$	$V_{NF} = 0\text{ V}$ , Output Open	—	50	—	ns
		$t_f$		—	500	—	
Output leakage current		Upper side	$V_{CC} = 50\text{ V}$	—	—	5	$\mu\text{A}$
		Lower side		$I_{LL}$	—	—	

**Measurement waveform**

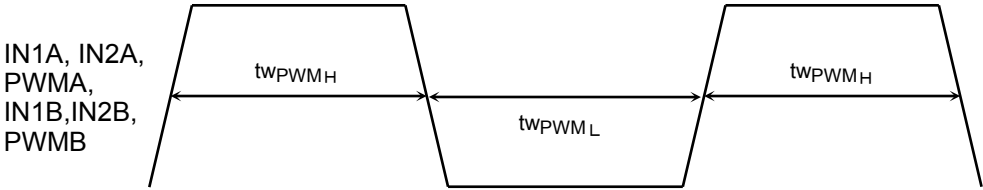

**Figure 1 Timing Waveforms and Names**

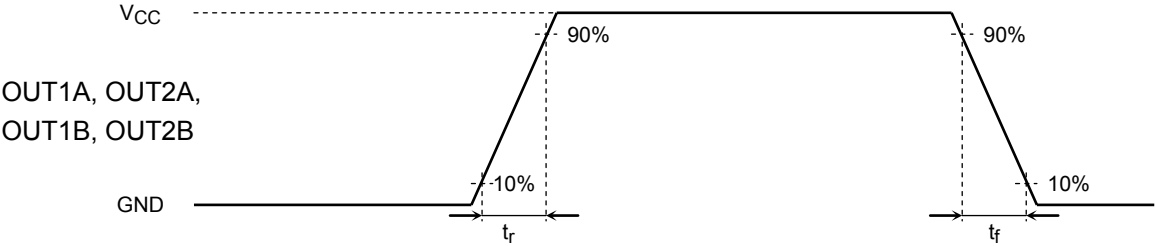

**Figure 2 Timing Waveforms and Names**

## Power dissipation

### TB67H302HG

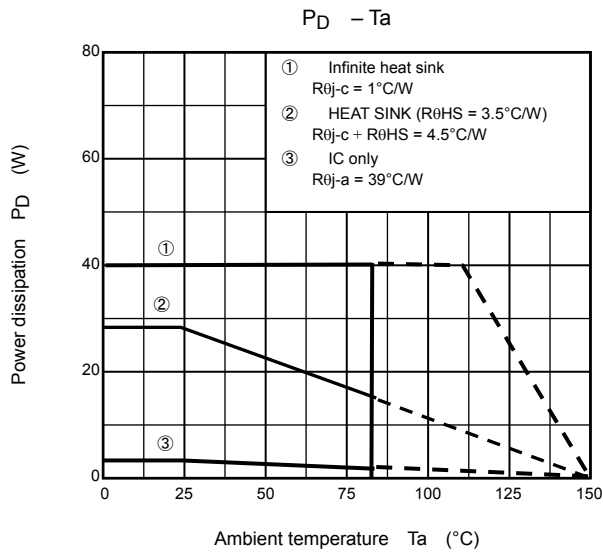

## Application circuit

### (1) Direct PWM

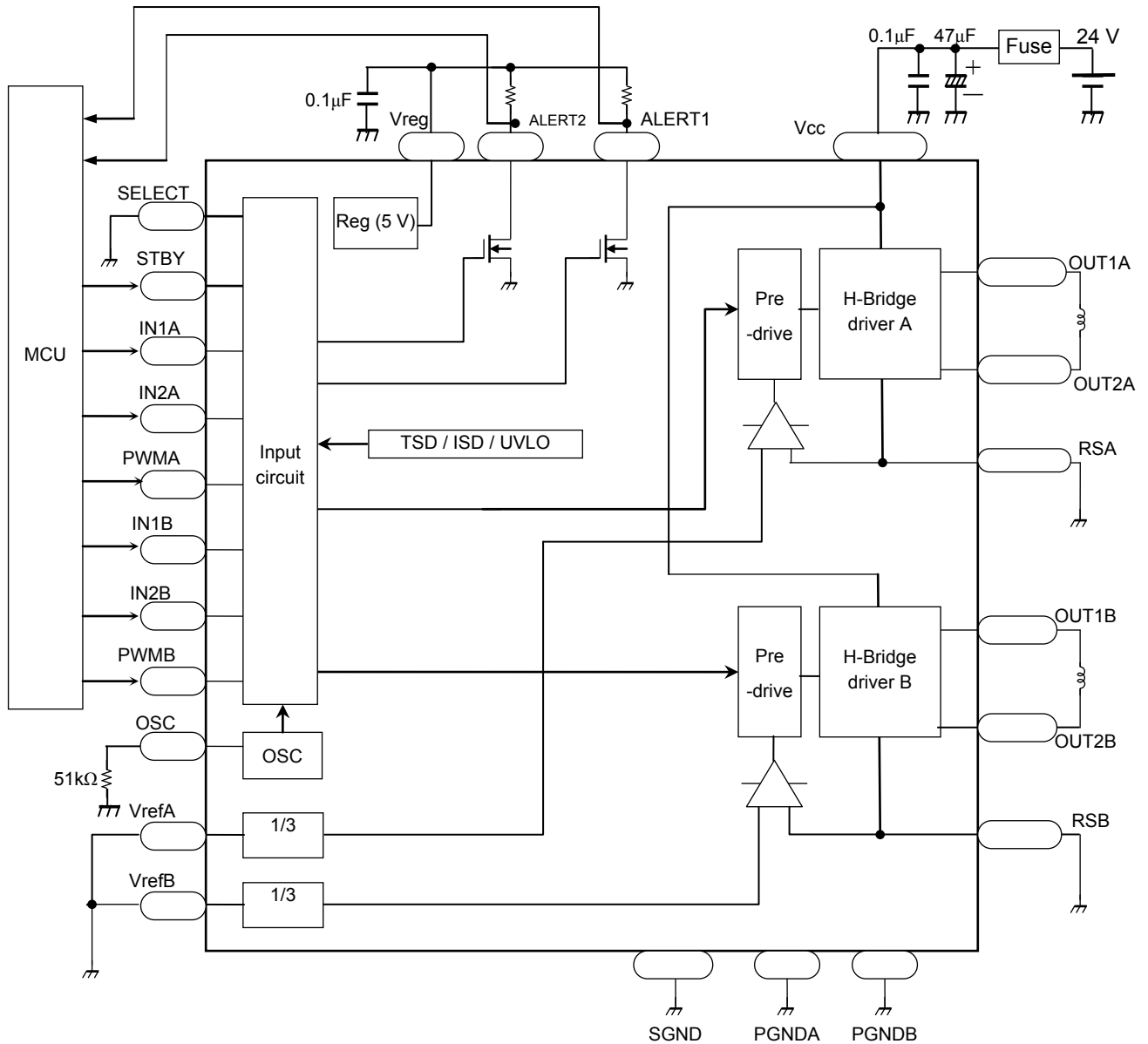

Set SELECT "L" in direct PWM drive.

RSA should be connected to PGNDA.  
RSB should be connected to PGNDB.

VrefA and VrefB should be connected to SGND each.



- Note 1: Generally, some ICs are highly sensitive to electrostatic discharge. When handling them, ensure that the environment is protected against electrostatic discharge.
- Note 2: Capacitors for the power supply lines should be connected as close to the IC as possible.
- Note 3: Pay attention for wire layout of PCB not to allow GND line to have large common impedance.
- Note 4: External capacitor connecting to Vreg should be 0.1 $\mu$ F. Pay attention for the wire between this capacitor and Vreg terminal and the wire between this capacitor and SGND not to be influenced by noise.
- Note 5: The IC may not operate normally when large common impedance is existed in GND line or the IC is easily influenced by noise. For example, if the IC operates continuously for a long time under the circumstance of large current and high voltage, the output according to the input control signal may be different from the I/O function table of this document. And so, the IC may not operate normally. To avoid this malfunction, make sure to conduct Note.2 to Note.4 and evaluate the IC enough before using the IC.
- Note 6: As for a brush motor, the noise, which is generated from the brushes in the motor during the motor rotation, influences on the IC operation. For example, it may cause a malfunction of the ISD circuit and then finally the IC may not work normally. In this case, connect a capacitor between the motor terminals in order to reduce the noise.

The appropriate value of the capacitor depends on the magnitude of the noise and the inductance of the motor coil. Please determine the value according to each actual equipment and condition. The connecting position of the capacitor should be conformed because the effect of the capacitor is different depending on the position of the capacitor which is near the IC or the motor.

## (2) Constant-current PWM

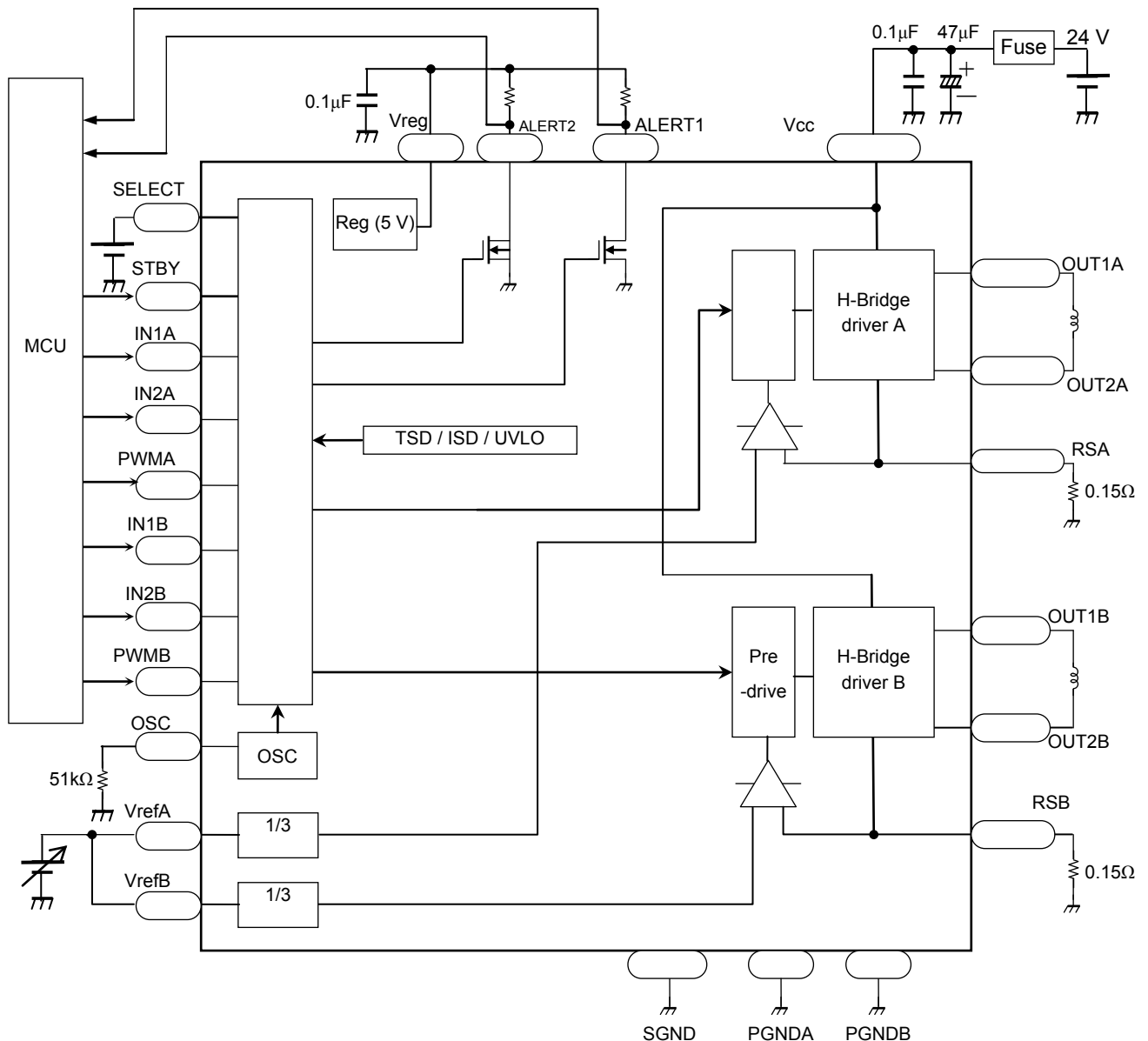

Set SELECT "H" in constant-current PWM drive.

RSA should be connected to PGNDA via RNFA.

RSB should be connected to PGNDB via RNFB.

Output current is set as follows;

$$A_{ch} \quad I_o = (1/3 \times V_{refA}) \div RNFA$$

$$B_{ch} \quad I_o = (1/3 \times V_{refB}) \div RNFB$$

Set RNFA, RNFB, VrefA and VrefB as follows;

$0.11\Omega \leq RNFA \leq 0.5\Omega$ ,  $0.11\Omega \leq RNFB \leq 0.5\Omega$ ,  $0.3V \leq V_{refA} \leq 1.95V$  and  $0.3V \leq V_{refB} \leq 1.95V$

Note 1: Generally, some ICs are highly sensitive to electrostatic discharge. When handling them, ensure that the environment is protected against electrostatic discharge.

Note 2: Capacitors for the power supply lines should be connected as close to the IC as possible.

Note 3: Current detection resistance (RNF) should be connected as close as the IC as possible.

Note 4: Pay attention for wire layout of PCB not to allow GND line to have large common impedance.

Note 5: External capacitor connecting to Vreg should be 0.1 $\mu$ F. Pay attention for the wire between this capacitor and Vreg terminal and the wire between this capacitor and SGND not to be influenced by noise.

Note 6: The IC may not operate normally when large common impedance is existed in GND line or the IC is easily influenced by noise. For example, if the IC operates continuously for a long time under the circumstance of large current and high voltage, the output according to the input control signal may be different from the I/O function table of this document. And so, the IC may not operate normally. To avoid this malfunction, make sure to conduct Note.2 to Note.5 and evaluate the IC enough before using the IC.

Note 7: As for a brush motor, the noise, which is generated from the brushes in the motor during the motor rotation, influences on the IC operation. For example, it may cause a malfunction of the ISD circuit and then finally the IC may not work normally. In this case, connect a capacitor between the motor terminals in order to reduce the noise.

The appropriate value of the capacitor depends on the magnitude of the noise and the inductance of the motor coil. Please determine the value according to each actual equipment and condition. The connecting position of the capacitor should be conformed because the effect of the capacitor is different depending on the position of the capacitor which is near the IC or the motor.

## Package Dimensions

Unit: mm

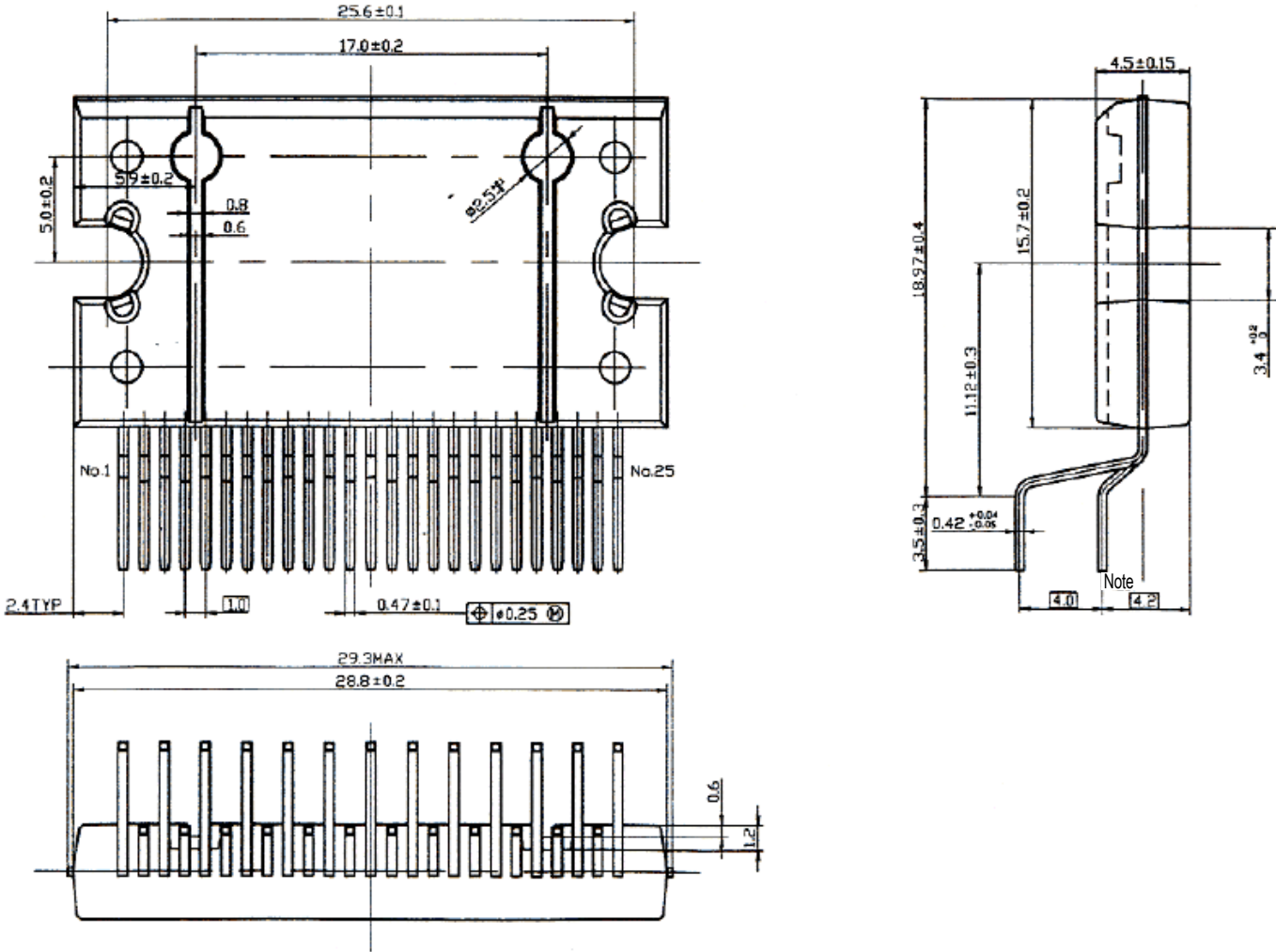

Note : These dimensions are measured from the surface of the heat sink.

Weight: 7.7 g (typ.)

## Notes on Contents

### 1. Block Diagrams

Some of the functional blocks, circuits, or constants in the block diagram may be omitted or simplified for explanatory purposes.

### 2. Equivalent Circuits

The equivalent circuit diagrams may be simplified or some parts of them may be omitted for explanatory purposes.

### 3. Timing Charts

Timing charts may be simplified for explanatory purposes.

### 4. Application Circuits

The application circuits shown in this document are provided for reference purposes only. Thorough evaluation is required, especially at the mass production design stage.

Toshiba does not grant any license to any industrial property rights by providing these examples of application circuits.

### 5. Test Circuits

Components in the test circuits are used only to obtain and confirm the device characteristics. These components and circuits are not guaranteed to prevent malfunction or failure from occurring in the application equipment.

## IC Usage Considerations

### Notes on handling of ICs

- [1] The absolute maximum ratings of a semiconductor device are a set of ratings that must not be exceeded, even for a moment. Do not exceed any of these ratings.  
Exceeding the rating(s) may cause the device breakdown, damage or deterioration, and may result injury by explosion or combustion.
- [2] Use an appropriate power supply fuse to ensure that a large current does not continuously flow in case of over current and/or IC failure. The IC will fully break down when used under conditions that exceed its absolute maximum ratings, when the wiring is routed improperly or when an abnormal pulse noise occurs from the wiring or load, causing a large current to continuously flow and the breakdown can lead smoke or ignition. To minimize the effects of the flow of a large current in case of breakdown, appropriate settings, such as fuse capacity, fusing time and insertion circuit location, are required.
- [3] If your design includes an inductive load such as a motor coil, incorporate a protection circuit into the design to prevent device malfunction or breakdown caused by the current resulting from the inrush current at power ON or the negative current resulting from the back electromotive force at power OFF. IC breakdown may cause injury, smoke or ignition.  
Use a stable power supply with ICs with built-in protection functions. If the power supply is unstable, the protection function may not operate, causing IC breakdown. IC breakdown may cause injury, smoke or ignition.
- [4] Do not insert devices in the wrong orientation or incorrectly.  
Make sure that the positive and negative terminals of power supplies are connected properly.  
Otherwise, the current or power consumption may exceed the absolute maximum rating, and exceeding the rating(s) may cause the device breakdown, damage or deterioration, and may result injury by explosion or combustion.  
In addition, do not use any device that is applied the current with inserting in the wrong orientation or incorrectly even just one time.

**Points to remember on handling of ICs****(1) Over current Protection Circuit**

Over current protection circuits (referred to as current limiter circuits) do not necessarily protect ICs under all circumstances. If the over current protection circuits operate against the over current, clear the over current status immediately.

Depending on the method of use and usage conditions, such as exceeding absolute maximum ratings can cause the over current protection circuit to not operate properly or IC breakdown before operation. In addition, depending on the method of use and usage conditions, if over current continues to flow for a long time after operation, the IC may generate heat resulting in breakdown.

**(2) Thermal Shutdown Circuit**

Thermal shutdown circuits do not necessarily protect ICs under all circumstances. If the thermal shutdown circuits operate against the over temperature, clear the heat generation status immediately.

Depending on the method of use and usage conditions, such as exceeding absolute maximum ratings can cause the thermal shutdown circuit to not operate properly or IC breakdown before operation.

**(3) Heat Radiation Design**

In using an IC with large current flow such as power amp, regulator or driver, please design the device so that heat is appropriately radiated, not to exceed the specified junction temperature ( $T_j$ ) at any time and condition. These ICs generate heat even during normal use. An inadequate IC heat radiation design can lead to decrease in IC life, deterioration of IC characteristics or IC breakdown. In addition, please design the device taking into consideration the effect of IC heat radiation with peripheral components.

**(4) Back-EMF**

When a motor rotates in the reverse direction, stops or slows down abruptly, a current flow back to the motor's power supply due to the effect of back-EMF. If the current sink capability of the power supply is small, the device's motor power supply and output pins might be exposed to conditions beyond absolute maximum ratings. To avoid this problem, take the effect of back-EMF into consideration in system design.

**(5) Short-circuiting between outputs, air contamination faults, faults due to improper grounding, short-circuiting between contiguous pins**

Utmost care is necessary in the design of the power supply lines, GND lines, and output lines since the IC may be destroyed by short-circuiting between outputs, air contamination faults, or faults due to improper grounding, or by short-circuiting between contiguous pins. They may destroy not only the IC but also peripheral parts and may contribute to injuries for users. Over current may continue to flow in the IC because of this destruction and cause smoke or ignition of the IC. Expect the volume of this over current and add an appropriate power supply fuse in order to minimize the effects of the over current. Capacity of the fuse, fusing time, and the inserting position in the circuit should be configured suitably.

**RESTRICTIONS ON PRODUCT USE**

- Toshiba Corporation, and its subsidiaries and affiliates (collectively "TOSHIBA"), reserve the right to make changes to the information in this document, and related hardware, software and systems (collectively "Product") without notice.
- This document and any information herein may not be reproduced without prior written permission from TOSHIBA. Even with TOSHIBA's written permission, reproduction is permissible only if reproduction is without alteration/omission.
- Though TOSHIBA works continually to improve Product's quality and reliability, Product can malfunction or fail. Customers are responsible for complying with safety standards and for providing adequate designs and safeguards for their hardware, software and systems which minimize risk and avoid situations in which a malfunction or failure of Product could cause loss of human life, bodily injury or damage to property, including data loss or corruption. Before customers use the Product, create designs including the Product, or incorporate the Product into their own applications, customers must also refer to and comply with (a) the latest versions of all relevant TOSHIBA information, including without limitation, this document, the specifications, the data sheets and application notes for Product and the precautions and conditions set forth in the "TOSHIBA Semiconductor Reliability Handbook" and (b) the instructions for the application with which the Product will be used with or for. Customers are solely responsible for all aspects of their own product design or applications, including but not limited to (a) determining the appropriateness of the use of this Product in such design or applications; (b) evaluating and determining the applicability of any information contained in this document, or in charts, diagrams, programs, algorithms, sample application circuits, or any other referenced documents; and (c) validating all operating parameters for such designs and applications. **TOSHIBA ASSUMES NO LIABILITY FOR CUSTOMERS' PRODUCT DESIGN OR APPLICATIONS.**
- **PRODUCT IS NEITHER INTENDED NOR WARRANTED FOR USE IN EQUIPMENTS OR SYSTEMS THAT REQUIRE EXTRAORDINARILY HIGH LEVELS OF QUALITY AND/OR RELIABILITY, AND/OR A MALFUNCTION OR FAILURE OF WHICH MAY CAUSE LOSS OF HUMAN LIFE, BODILY INJURY, SERIOUS PROPERTY DAMAGE AND/OR SERIOUS PUBLIC IMPACT ("UNINTENDED USE").** Except for specific applications as expressly stated in this document, Unintended Use includes, without limitation, equipment used in nuclear facilities, equipment used in the aerospace industry, medical equipment, equipment used for automobiles, trains, ships and other transportation, traffic signaling equipment, equipment used to control combustions or explosions, safety devices, elevators and escalators, devices related to electric power, and equipment used in finance-related fields. **IF YOU USE PRODUCT FOR UNINTENDED USE, TOSHIBA ASSUMES NO LIABILITY FOR PRODUCT.** For details, please contact your TOSHIBA sales representative.
- Do not disassemble, analyze, reverse-engineer, alter, modify, translate or copy Product, whether in whole or in part.
- Product shall not be used for or incorporated into any products or systems whose manufacture, use, or sale is prohibited under any applicable laws or regulations.
- The information contained herein is presented only as guidance for Product use. No responsibility is assumed by TOSHIBA for any infringement of patents or any other intellectual property rights of third parties that may result from the use of Product. No license to any intellectual property right is granted by this document, whether express or implied, by estoppel or otherwise.
- **ABSENT A WRITTEN SIGNED AGREEMENT, EXCEPT AS PROVIDED IN THE RELEVANT TERMS AND CONDITIONS OF SALE FOR PRODUCT, AND TO THE MAXIMUM EXTENT ALLOWABLE BY LAW, TOSHIBA (1) ASSUMES NO LIABILITY WHATSOEVER, INCLUDING WITHOUT LIMITATION, INDIRECT, CONSEQUENTIAL, SPECIAL, OR INCIDENTAL DAMAGES OR LOSS, INCLUDING WITHOUT LIMITATION, LOSS OF PROFITS, LOSS OF OPPORTUNITIES, BUSINESS INTERRUPTION AND LOSS OF DATA, AND (2) DISCLAIMS ANY AND ALL EXPRESS OR IMPLIED WARRANTIES AND CONDITIONS RELATED TO SALE, USE OF PRODUCT, OR INFORMATION, INCLUDING WARRANTIES OR CONDITIONS OF MERCHANTABILITY, FITNESS FOR A PARTICULAR PURPOSE, ACCURACY OF INFORMATION, OR NONINFRINGEMENT.**
- Do not use or otherwise make available Product or related software or technology for any military purposes, including without limitation, for the design, development, use, stockpiling or manufacturing of nuclear, chemical, or biological weapons or missile technology products (mass destruction weapons). Product and related software and technology may be controlled under the applicable export laws and regulations including, without limitation, the Japanese Foreign Exchange and Foreign Trade Law and the U.S. Export Administration Regulations. Export and re-export of Product or related software or technology are strictly prohibited except in compliance with all applicable export laws and regulations.
- Please contact your TOSHIBA sales representative for details as to environmental matters such as the RoHS compatibility of Product. Please use Product in compliance with all applicable laws and regulations that regulate the inclusion or use of controlled substances, including without limitation, the EU RoHS Directive. **TOSHIBA ASSUMES NO LIABILITY FOR DAMAGES OR LOSSES OCCURRING AS A RESULT OF NONCOMPLIANCE WITH APPLICABLE LAWS AND REGULATIONS.**