

Marketed By:-
 Intech Automation, Chennai-600 032
 Phone: 43534888 Mob: 9940538888 Fax: 43534889
 E-mail: info@intechautomation.in Website: www.intechautomation.in

▶ SMALL BRUSH MOTORS

TYPE	SERIES
KM	KM-3429 SERIES KM-3448 SERIES

- 1. DIMENSIONS
- 2. PERFORMANCE DATA

— DIMENSIONS

KM3429 SERIES

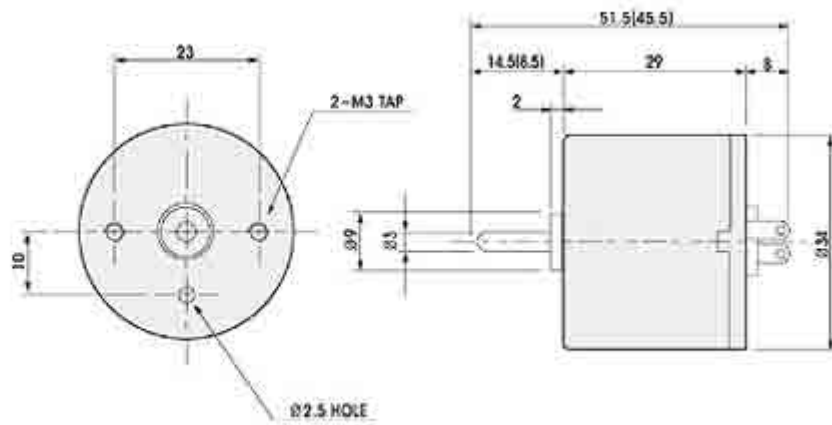

KM3448 SERIES

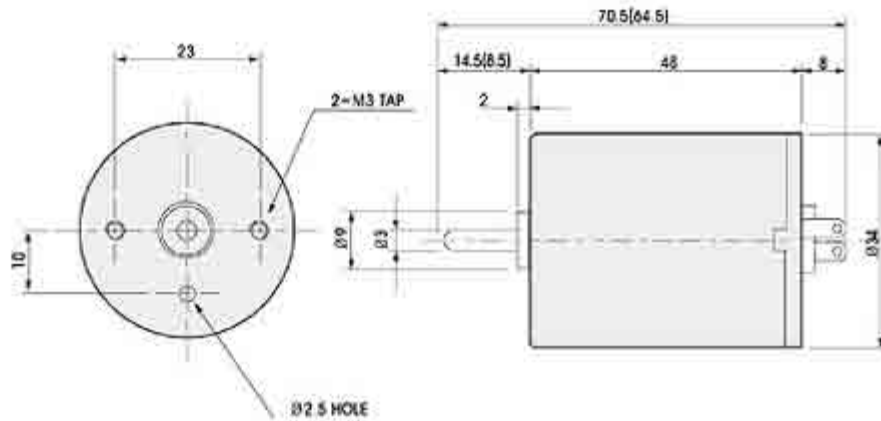

PERFORMANCE DATA

ITEM MODEL	VOLTAGE (V)	NO LOAD		AT MAX EFF			STALL		WEIGHT (g)
		mA	RPM	g.Cm	mA	RPM	mA	g.Cm	
KM3429A	24DC	50	5200	40	200	4500	950	370	90
KM3429B	24DC	100	9500	45	250	8000	2950	400	90
KM3429C	12DC	140	7500	40	230	6500	3150	380	90
KM3429D	24DC	25	2500	20	100	2200	295	180	90
KM3429E	24DC	60	7000	40	220	6000	1250	380	90
KM3448A	24DC	70	5200	80	250	4500	1950	790	140
KM3448B	24DC	90	7500	90	300	6500	3250	850	140
KM3448C	24DC	10	950	15	20	850	110	150	140
KM3448D	12DC	100	5200	80	300	4500	3200	830	140
KM3448E	24DC	20	2500	40	40	2000	490	390	140



Marketed By:- **Intech Automation**

2nd Floor, S-2, Thiru. Vi. Ka. Industrial Estate, Guindy, Chennai-600 032

Phone: 43534888 Mob: 99405 38888 Fax: 43534889

E-mail: info@intechautomation.in Website: www.intechautomation.in