

November 1996

FM IF Wideband Amplifier

Features

- **Exceptionally High Amplifier Gain**
 - Power Gain at 4.5MHz 75dB
- **Excellent Input Limiting Characteristics**
 - Limiting Voltage (Knee) at 10.7MHz 600 μ V (Typ)
- **Wide Frequency Capability:**
 - Bandwidth..... 100kHz to 20MHz

Applications

- FM IF Amplifiers
- FM Communication Receivers
- TV IF Amplifiers

Description

The CA3012 is an FM IF wideband amplifier with 3 limiter gain stages in a bipolar monolithic technology. The pin 1 input is an open base and has a separate feedback bias. The feedback bias pin, DC FB BYPASS, is externally bypassed and provides the means for a tuned coil input to the IF IN pin. The output is a high impedance open collector which may be matched to a tuned transformer, driving an FM detector. Internal regulation circuits provide DC bias to the gain stages and DC feedback circuit.

The CA3012 is intended for FM limiting applications requiring high gain.

Ordering Information

PART NUMBER	TEMP. RANGE (°C)	PACKAGE	PKG. NO.
CA3012	-55 to 125	10 Ld Metal Can	T10.C

Pinout

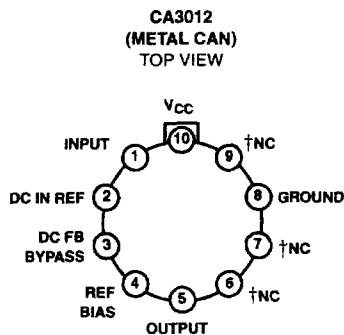

Schematic Diagram

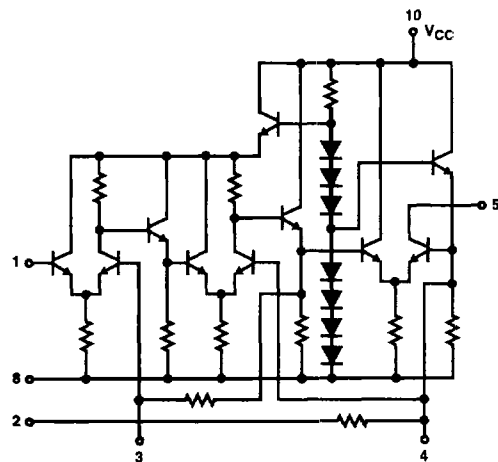

CA3012

Absolute Maximum Ratings $T_A = 25^\circ\text{C}$

Maximum Supply Voltage V_{CC} , Pin 10	10V
Maximum Output Voltage, Pin 5	13V
Maximum Input Signal Voltage between Pin 1 and Pin 2	$\pm 3\text{V}$

Thermal Information

Thermal Resistance (Typical, Note 1)	θ_{JA} ($^\circ\text{C}/\text{W}$)	θ_{JC} ($^\circ\text{C}/\text{W}$)
Metal Can Package	175	100
Maximum Junction Temperature	175 $^\circ\text{C}$	
Maximum Storage Temperature Range	-65 $^\circ\text{C}$ to 150 $^\circ\text{C}$	
Maximum Lead Temperature (Soldering 10s)	300 $^\circ\text{C}$	

Operating Conditions

Temperature Range	-55 $^\circ\text{C}$ to 125 $^\circ\text{C}$
Supply Voltage Range (Typical)	5.5V to 10V

CAUTION: Stresses above those listed in "Absolute Maximum Ratings" may cause permanent damage to the device. This is a stress only rating and operation of the device at these or any other conditions above those indicated in the operational sections of this specification is not implied.

NOTE:

- θ_{JA} is measured with the component mounted on an evaluation PC board in free air.

Electrical Specifications

PARAMETER	SYMBOL	TEST CONDITIONS				MIN	TYP	MAX	UNITS
		SETUP AND PROCEDURE (FIGURE)	FREQUENCY f (MHz)	DC SUPPLY VOLTAGE V_{CC} (V)	TEMP ($^\circ\text{C}$)				
Total Device Dissipation (Note 2)	P_T	1	-	6	-55	66	80	135	mW
					25	66	90	121	mW
					125	65	70	121	mW
		-	7.5	-55	97	130	190	mW	
				25	97	120	167	mW	
				125	95	100	167	mW	
		-	10	-55	150	210	275	mW	
				25	150	190	255	mW	
				125	150	160	255	mW	
Voltage Gain (Note 3)	A	3	1	6	-55	50	55	-	dB
					25	60	66	-	dB
					125	50	61	-	dB
		3	1	7.5	-55	55	59	-	dB
					25	65	70	-	dB
					125	55	65	-	dB
		3	1	10	-55	55	61	-	dB
					25	65	71	-	dB
					125	55	66	-	dB
		3	4.5	7.5	25	60	67	-	dB
					10.7	7.5	25	55	61
		Input Impedance Components							
Parallel Input Resistance	R_{IN}	6	4.5	7.5	25	-	3	-	k Ω
Parallel Input Capacitance	C_{IN}	6	4.5	7.5	25	-	7	-	pF
Output Impedance Components									
Parallel Output Resistance	R_{OUT}	8	4.5	7.5	25	-	31.5	-	k Ω
Parallel Output Capacitance	C_{OUT}	8	4.5	7.5	25	-	4.2	-	pF
Noise Figure	NF	10	4.5	7.5	25	-	8.7	-	dB
Input Limiting Voltage (Knee)	$V_{I(LIM)}$	3	4.5	7.5	25	-	300	400	μV

NOTES:

- The total current drain may be determined by dividing P_T by V_{CC} .
- Recommended minimum DC supply voltage (V_{CC}) is 5.5V. Nominal load current flowing into terminal 5 is 1.5mA at 7.5V.



 SPECIAL ANALOG
 CIRCUITS

Typical Performance Curves and Test Setups

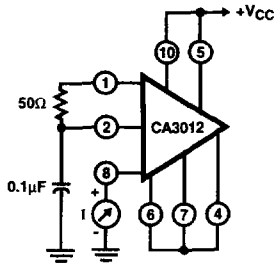

FIGURE 1. DISSIPATION TEST SETUP

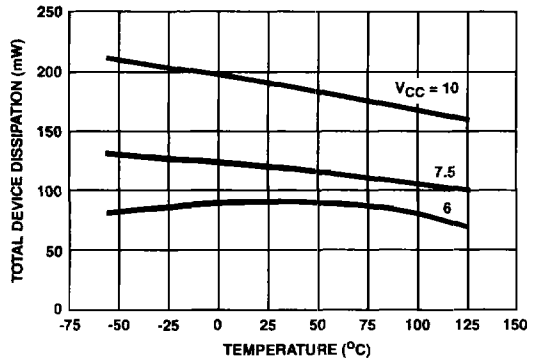

FIGURE 2. DISSIPATION vs TEMPERATURE

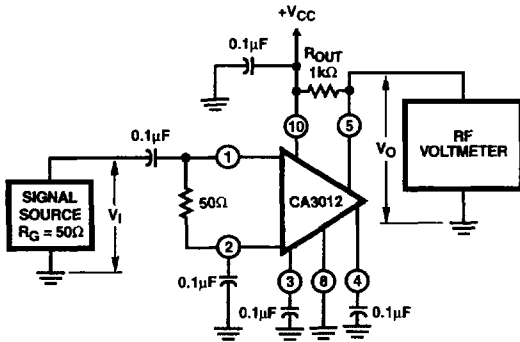

FIGURE 3. VOLTAGE GAIN TEST SETUP

Procedures

A. Voltage Gain

1. Set input frequency at desired value, $V_I = 100\mu V_{RMS}$
2. Record V_O
3. Calculate Voltage Gain A from $A = 20 \log_{10} V_O/V_I$
4. Repeat steps 1, 2 and 3 for each frequency and/or for temperature desired

B. Input Limiting Voltage (Knee)

1. Repeat steps A1 and A2, using $V_I = 100mV$
2. Decrease V_I to the level at which V_O is 3dB below its value for $V_I = 100mV$
3. Record V_I as Input Limiting Voltage (Knee)

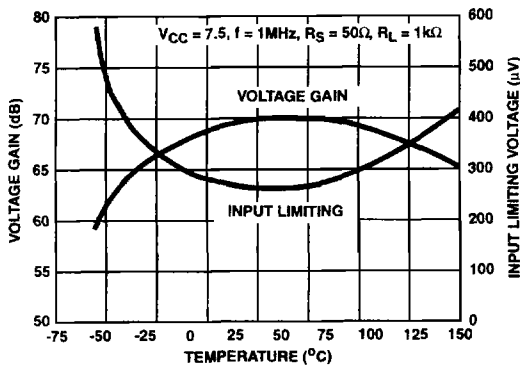

FIGURE 4. VOLTAGE GAIN AND INPUT LIMITING VOLTAGE vs TEMPERATURE

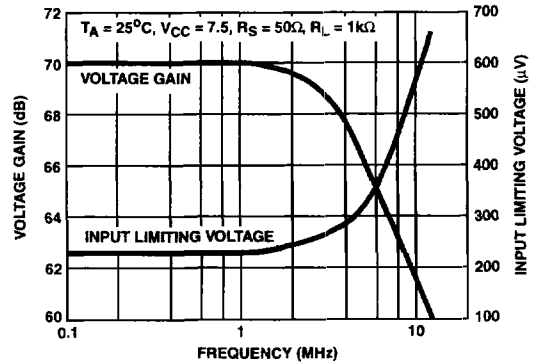

FIGURE 5. VOLTAGE GAIN AND INPUT LIMITING VOLTAGE vs FREQUENCY

Typical Performance Curves and Test Setups (Continued)

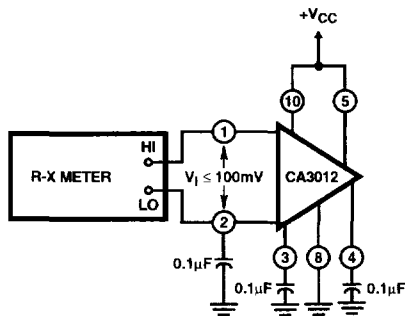

FIGURE 6. INPUT IMPEDANCE TEST SETUP

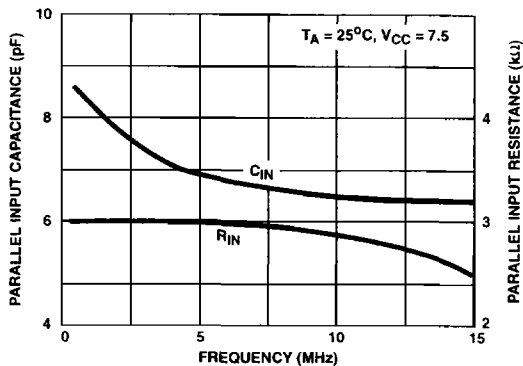

FIGURE 7. INPUT IMPEDANCE vs FREQUENCY

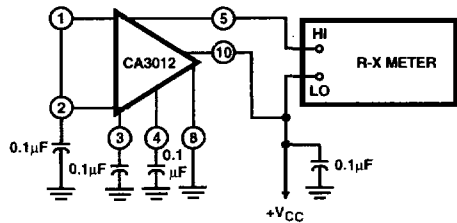

FIGURE 8. OUTPUT IMPEDANCE TEST SETUP

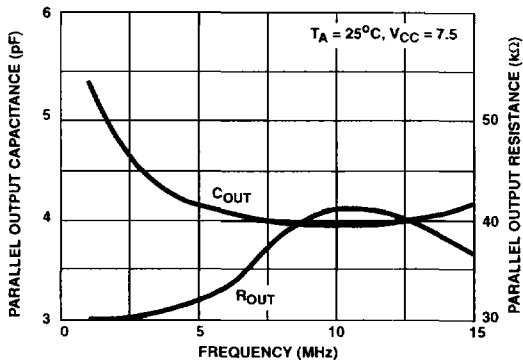

FIGURE 9. OUTPUT IMPEDANCE vs FREQUENCY

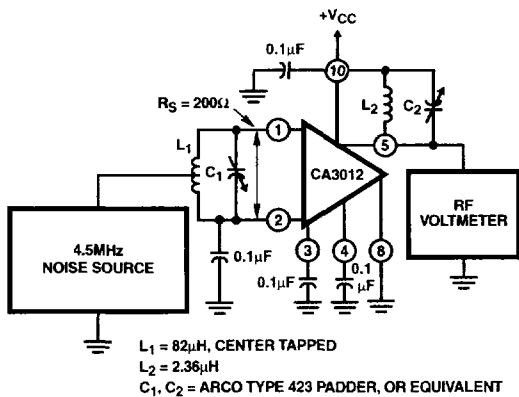

FIGURE 10.

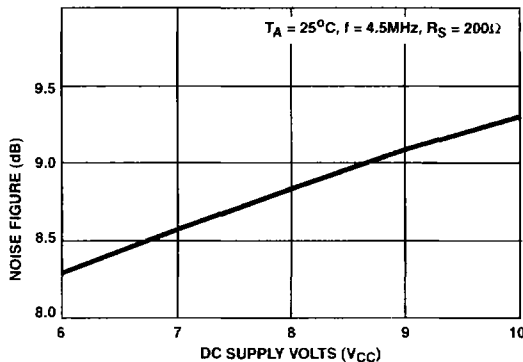

FIGURE 11. NOISE FIGURE vs DC SUPPLY VOLTAGE

CA3012

Typical Application

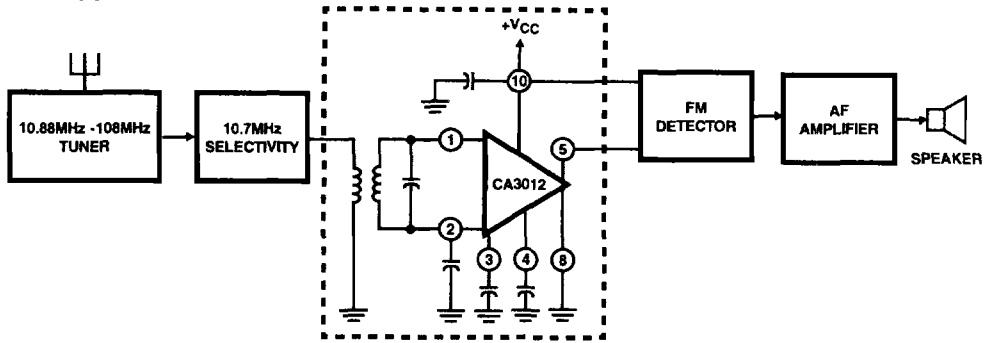

FIGURE 12. BLOCK DIAGRAM OF TYPICAL FM RECEIVER USING THE CA3012 INTEGRATED CIRCUIT WIDEBAND AMPLIFIER