

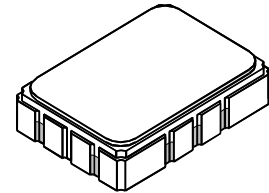

- Quartz Temperature Stability
- Small Size
- Hermetic 7 x 5 mm Surface-mount Case
- Complies with Directive 2002/95/EC (RoHS) 

SF2156B

**611 MHz
SAW Filter**



SMP-03-O Case

Absolute Maximum Ratings

Rating	Value	Units
Input Power Level	+10	dBm
DC Voltage	3	V
Operating Temperature Range	-20 to +70	°C
Storage Temperature Range in Tape and Reel	-40 to +85	°C
Suitable for Lead-free Soldering - Maximum Soldering Profile	260°C for 30 s	

Electrical Characteristics

Characteristic	Sym	Notes	Min	Typ	Max	Units
Center Frequency	f_C	1	611			MHz
Insertion Loss	IL_{MIN}			2.95	4.5	dB
3 dB Bandwidth	$BW_{3\text{ dB}}$		7	9.9		MHz
40 dB Bandwidth	$BW_{40\text{ dB}}$			20.4	24	MHz
Amplitude Ripple, 609.5 to 612.5 MHz	IL_{MIN}			0.4	1.3	dB _{p-p}
Rejection Reference to 0 dB						
520 to 560 MHz			38	43		dB
660 to 700 MHz			38	45		dB
Source impedance	Z_S			50		Ω
Load impedance	Z_L			50		Ω

Case Style	6	SMP-03-O 5 x 7 mm Nominal Footprint
Lid Symbolization (YY = year, WW = week)		RFM SF2156B YYWW



CAUTION: Electrostatic Sensitive Device. Observe precautions for handling.

Notes:

1. Unless noted otherwise, all specifications apply over the operating temperature range with filter soldered to the specified demonstration board with impedance matching to 50 Ω and measured with 50 Ω network analyzer.
2. Unless noted otherwise, all frequency specifications are referenced to the nominal center frequency, f_c .
3. Rejection is measured as attenuation below the minimum IL point in the passband. Rejection in final user application is dependent on PCB layout and external impedance matching design. See Application Note No. 42 for details.
4. "LRIP" or "L" after the part number indicates "low rate initial production" and "ENG" or "E" indicates "engineering prototypes."
5. The design, manufacturing process, and specifications of this filter are subject to change.
6. Tape and Reel Standard ANSI / EIA 481.
7. Either Port 1 or Port 2 may be used for either input or output in the design. However, impedances and impedance matching may vary between Port 1 and Port 2, so that the filter must always be installed in one direction per the circuit design.
8. US and international patents may apply.

Filter Plots

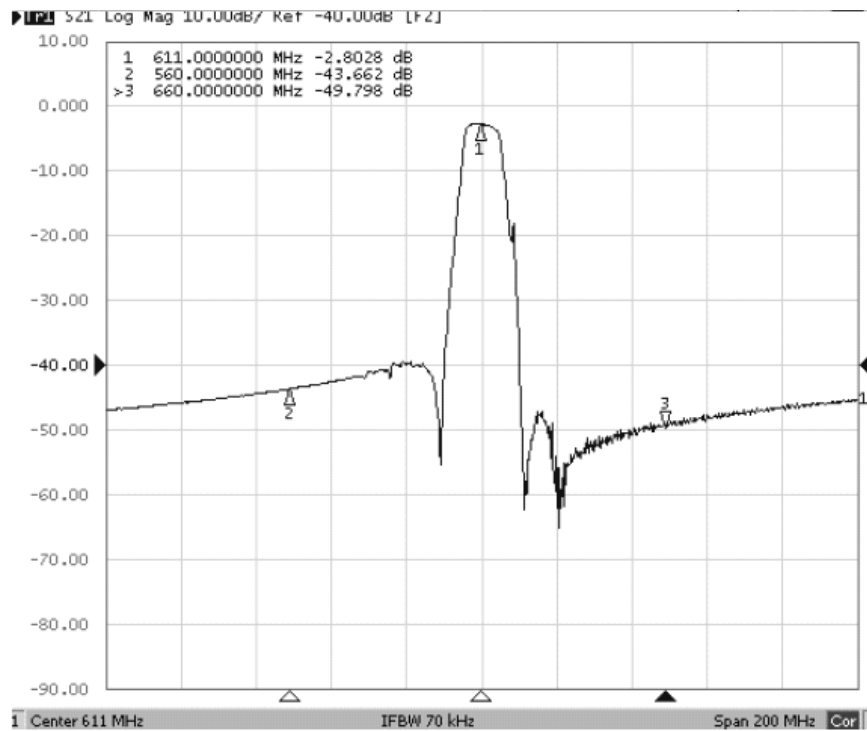
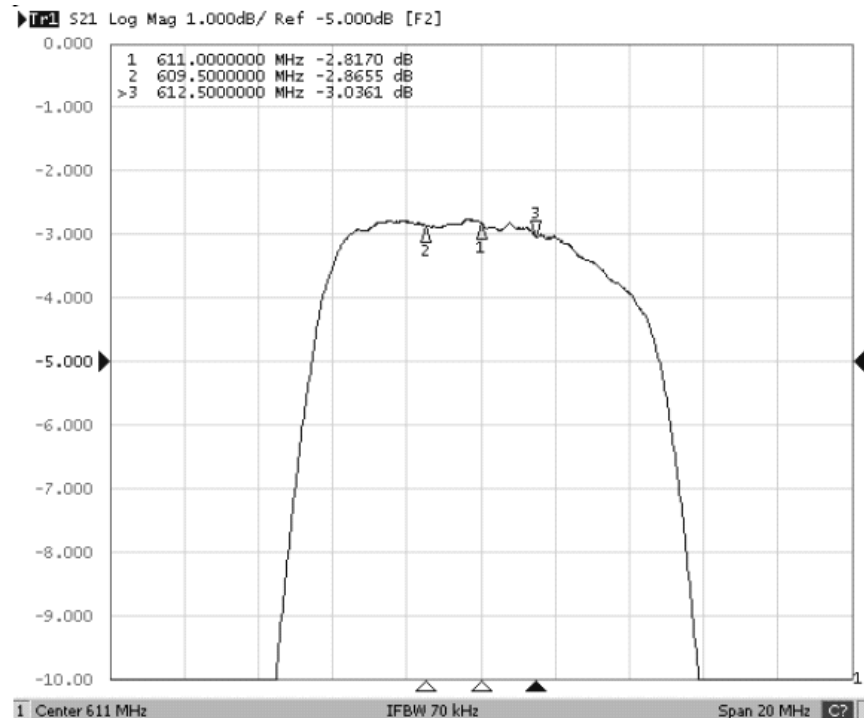

SMP-03-O 12-Terminal Ceramic Surface-mount Case

7.0 x 5.0 x 1.7 mm Nominal Footprint

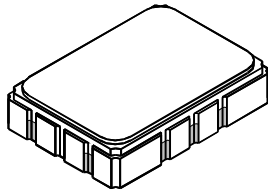

Measurement Circuit

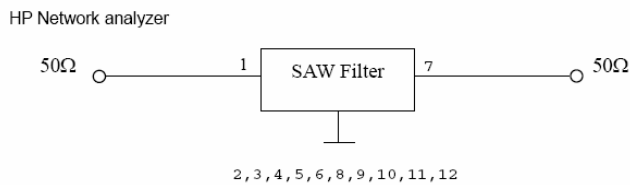

Electrical Connections	
Connection	Terminals
Input	1
Output	7
Ground	All others

Case Materials	
Solder Pad Plating	0.3 to 1.0 μm Gold over 1.27 to 8.89 μm Nickel
Lid Plating	2.0 to 3.0 μm Nickel
Body	Al_2O_3 Ceramic
Pb Free	

Typical PCB Land Pattern

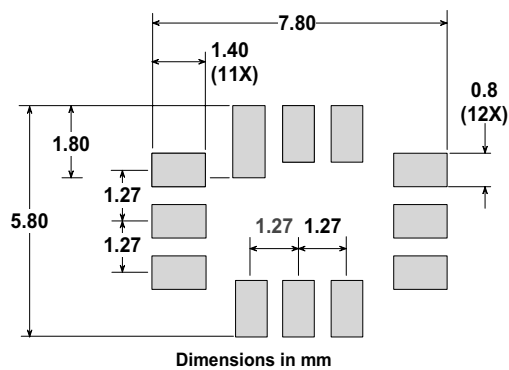

Case Drawing

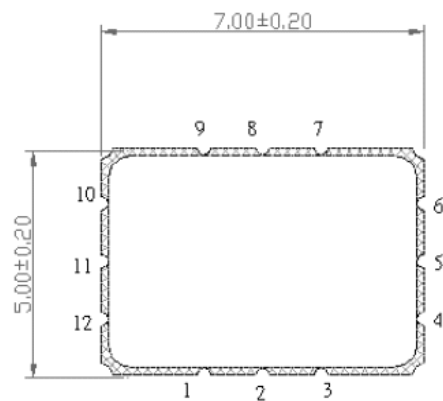

Dimensions in mm

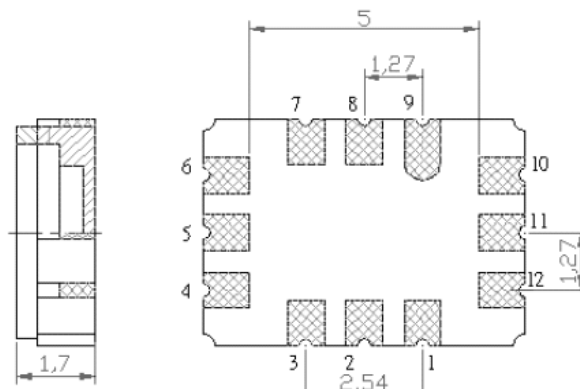

- #1: Input
- #7: Output
- #2,3,4,5,6,8,9,10,11,12: Ground

Tape and Reel Specifications

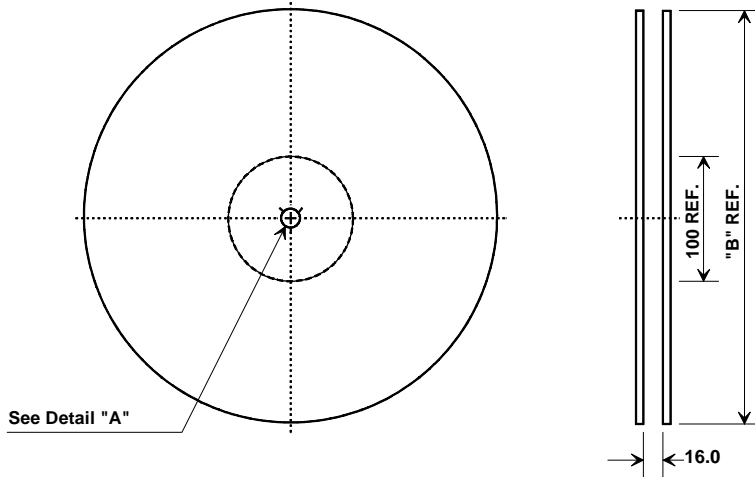

"B" Nominal Size		Quantity Per Reel
Inches	millimeters	
7	178	500
13	330	2000

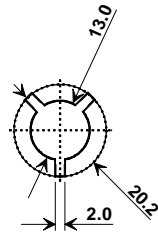

COMPONENT ORIENTATION and DIMENSIONS

Carrier Tape Dimensions	
Ao	5.5 mm
Bo	7.5 mm
Ko	2.0 mm
Pitch	8.0 mm
W	16.0 mm

