

PHT-S

PM Hysteresis Torque Controller

Types: 0.02, 0.05, 0.5

[PM: Permanent Magnet]

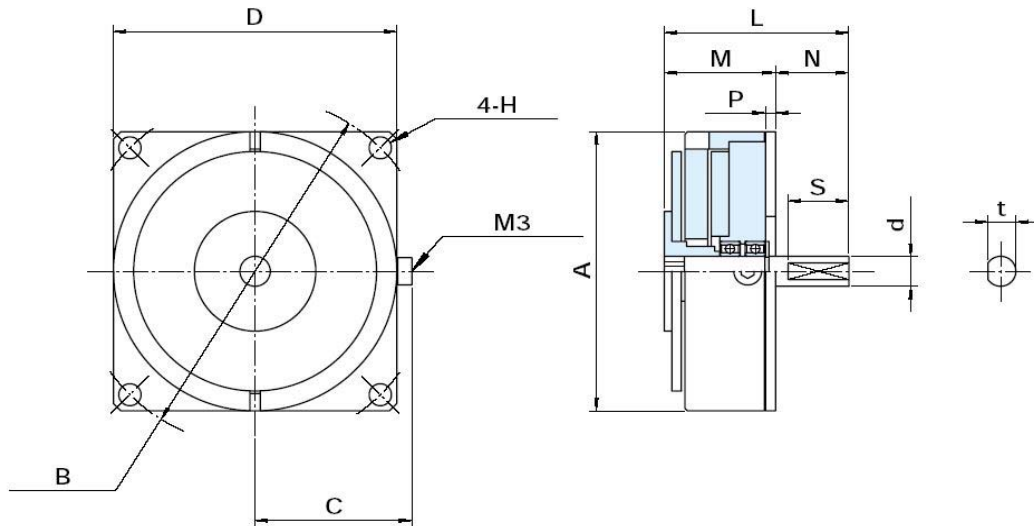

PHT		0.02S	0.05S	0.5S
Torque Range [in-lbs]		0.0044 ~ 0.027	0.0044 ~ 0.066	0.0089 ~ 0.49
Torque Range [gf-cm]		5.1 ~ 30.6	5.1 ~ 76.5	10.2 ~ 560.8
Max Slip Speed [rpm]		10000	10000	1800
Max Slip Wattage [W]		2.5	3	10
Moment of Inertia (J) [kg-cm ²]		0.0011	0.0048	0.103
Shaft [mm]	d	3	3	6
	t	2.6	2.6	5.5
Dimensions [mm]	A	26	32	56
	B	34	40	70
	C	16.5	19.5	31.5
	D	30	35	56
	H	3.4	3.4	4.4
	L	28	28	36.5
	M	16.7	18	22
	N	11.3	10	14.5
	P	2	2	2
	S	8	8	12
Weight [lbs / kg]		0.13 / 0.06	0.2 / 0.1	0.8 / 0.3

[1" = 25.4mm]