

Version :3.0**TECHNICAL SPECIFICATION****MODEL NO : PD080SL1**

The content of this information is subject to be changed without notice.
Please contact PVI or its agent for further information.

 Customer's Confirmation

Customer _____

Date _____

By _____

 PVI's Confirmation**FOR MORE INFORMATION:**

AZ DISPLAYS, INC.
75 COLUMBIA, ALISO VIEJO, CA, 92656
[Http://www.AZDISPLAYS.com](http://www.AZDISPLAYS.com)

Confirmed By _____

Prepared By _____

Revision History

Rev.	Eng.	Issued Date	Revised Content
V0.1	黃秀晶	July 25,2006	Preliminary
V0.2	黃秀晶	Oct 16,2006	Modify Page6 5-1) TFT-LCD Panel Driving
V0.3	黃秀晶	Dec 15,2006	Modify Page4 4. Mechanical Drawing of TFT-LCD Module Add Page26 16.Packing
1.0	黃秀晶	Jan 11, 2006	New
2.0	黃秀晶	May 28, 2007	Modify Page25 14. Reliability Test: LTOT/LTST from-20 to-25
3.0	黃秀晶	July 23, 2007	Modify Page6 Modify connect pin

TECHNICAL SPECIFICATION
CONTENTS

<i>NO.</i>	<i>ITEM</i>	<i>PAGE</i>
-	Cover	1
-	Revision History	2
-	Contents	3
1	Application	4
2	Features	4
3	Mechanical Specifications	4
4	Mechanical Drawing of TFT-LCD module	5
5	Connections and Functions for Interface Pins	7
6	Absolute Maximum Ratings	10
7	Electrical Characteristics	10
8	Pixel Arrangement	12
9	Display Colors and Input Data Signals	12
10	Input signal timing	16
11	Power On Sequence	20
12	Optical Characteristics	20
13	Handling Cautions	24
14	Reliability Test	25
15	Packing	26

1. Application

This data sheet applies to a color TFT LCD module, PD080SL1. The module applies to notebook PC, sub-note-book PC and other OA product, which require high quality flat panel display.

Prime View assume no responsibility for any damage resulting from the use of the device which dose not comply with the instructions and the precautions in these specification sheet.

2. Features

- . Amorphous silicon TFT LCD panel with back-light unit
- . Pixel in stripe configuration
- . Slim and compact, designed for O/A application
- . Display Colors : 262,144 colors or 16,777,216 colors
- . Backlight driving DC/AC inverter not included in this module
- . Long Life Lamp

3. Mechanical Specifications

Parameter	Specifications	Unit
Screen Size	8 (diagonal)	inch
Display Format	800×(RGB)×600	dot
Display Colors	262,144	
Active Area	162(H)×121.5 (V)	mm
Pixel Pitch	0.2025 (H)×0.2025 (V)	mm
Pixel Configuration	Stripe	
Outline Dimension	200(W)×152(H)×10.5(D) (typ.)	mm
Weight	343±15	g
Back-light	CCFL, 2 tubes	
Surface treatment	Anti-Glare	
Display mode	Normally white	
Gray scale inversion direction	6 (ref to Page 20 viewing angle)	o'clock

4. Mechanical Drawing of TFT-LCD Module

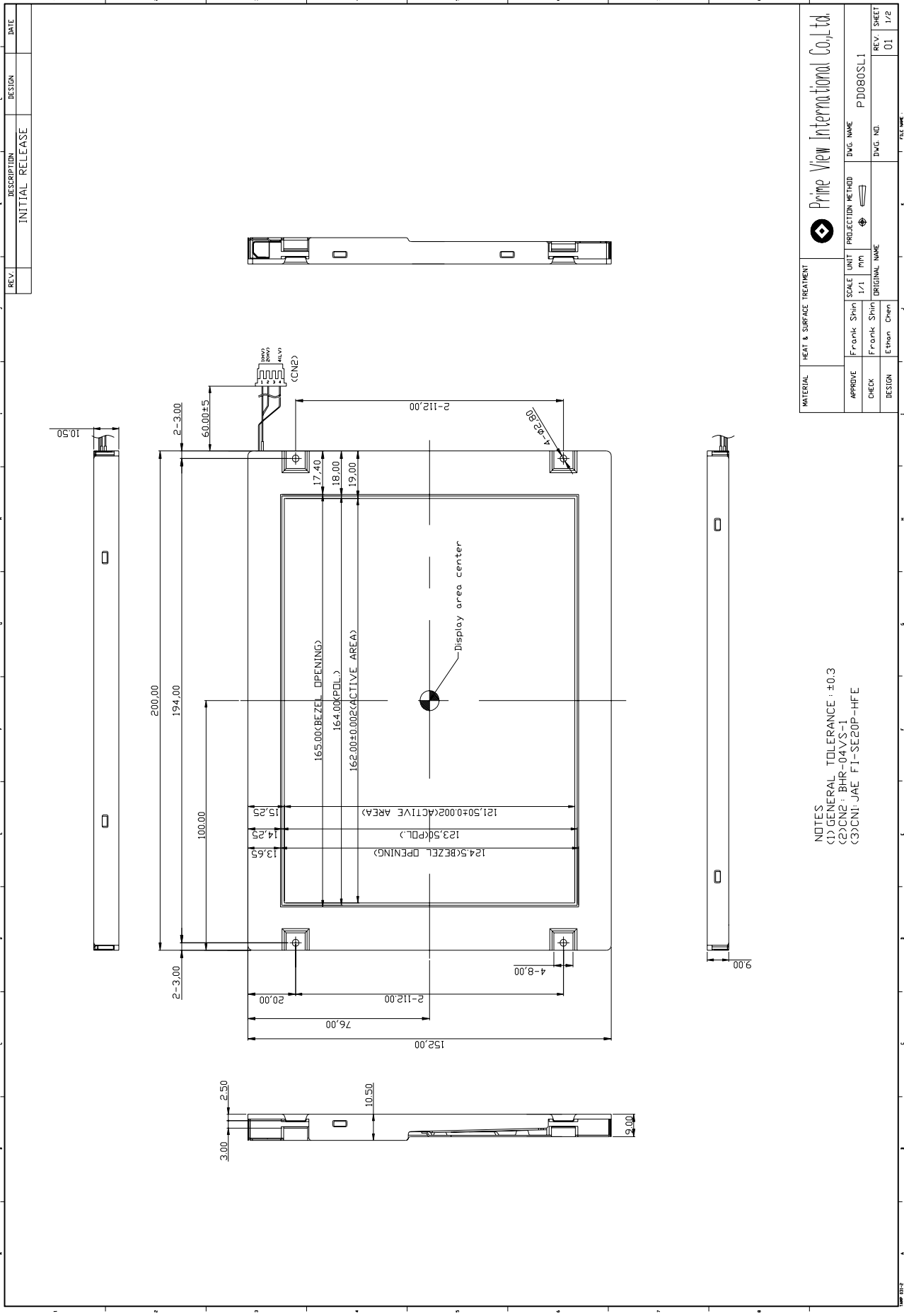

NOTES:
 (1) GENERAL TOLERANCE: ±0.3
 (2) CN2: BHR-04VS-1
 (3) CN1: JAE FT-SE20P-HFE

MATERIAL		HEAT & SURFACE TREATMENT		PRIME VIEW INTERNATIONAL CO., LTD.	
APPROVE	FRANK SHIN	SCALE	1/1	UNIT	MM
CHECK	FRANK SHIN	PROJECTION METHOD	1st	DWG. NAME	PD080SL1
DESIGN	ETIHAN CHEN	ORIGINAL NAME		DWG. NO.	
				REV.	01
				SHEET	1/2

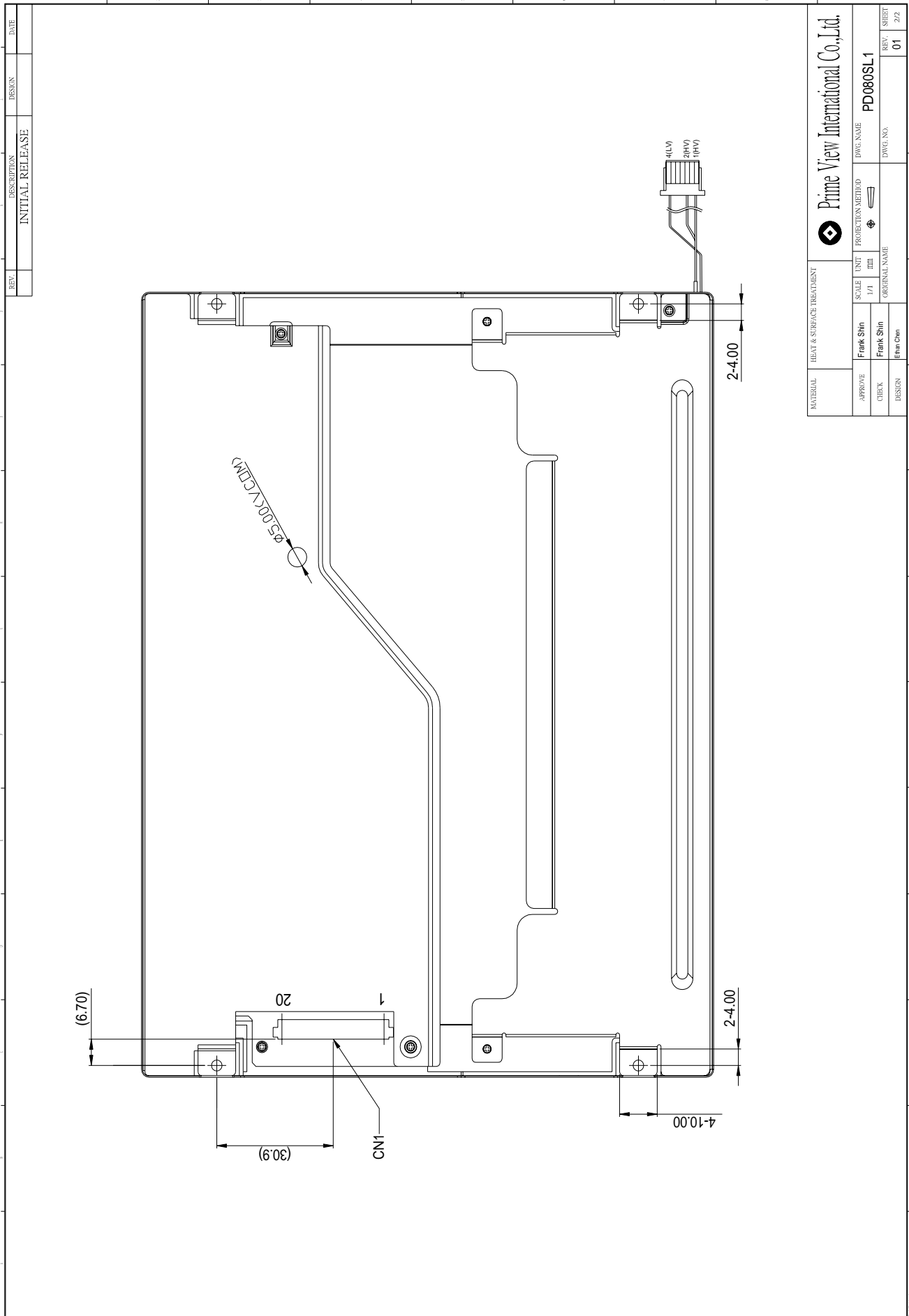

REVISION	DATE	DESCRIPTION	DESIGN
		INITIAL RELEASE	

MATERIAL	HEAT & SURFACE TREATMENT	PRIME VIEW INTERNATIONAL CO., LTD.
APPROVE	SCALE	DWG. NAME
	1/1	PD080SL1
CHECK	UNIT	PROJECTION METHOD
	mm	
DESIGN	ORIGINAL NAME	DWG. NO.
		REV.
		01
		SHEET
		2/2

5. CONNECTIONS AND FUNCTIONS FOR INTERFACE PINS

5-1) LCD panel signal processing board

CN1 socket (LCD module side): FI-SE20P-HFE(Japan Aviation Electronics Industry Limited(JAE))

Pin No.	Symbol	Signal	Remarks
1	A	D3+	Pixel data Note 5 - 1, 5 - 3
	B	GND	Ground Note 5 - 4
2	A	D3-	Pixel data Note 5 - 1, 5 - 3
	B	GND	Ground Note 5 - 4
3	DPS	Selection of scan direction	High: Reverse scan Low or Open: Normal scan Note 5 - 2
4	FRC	Selection of the number of colors	High: 16,777,216 colors Low or Open: 262,144 colors Note 5 - 1
5	GND	Ground	Note 5 - 4
6	CK+	Pixel clock	Note 5 - 3
7	CK-		
8	GND	Ground	Note 5 - 4
9	D2+	Pixel data	Note 5 - 3
10	D2-		
11	GND	Ground	Note 5 - 4
12	D1+	Pixel data	Note 5 - 3
13	D1-		
14	GND	Ground	Note 5 - 4
15	D0+	Pixel data	Note 5 - 3
16	D0-		
17	GND	Ground	Note 5 - 4
18	GND		
19	VDD	Power supply	Note 5 - 4
20	VDD		

 Note 5 - 1 : See **DISPLAY COLORS AND INPUT DATA SIGNALS** .

 Note 5 - 2 : See **SCANNING DIRECTIONS** .

Note 5 - 3 : Twist pair wires with 100Ω (Characteristic impedance) should be connected between LCD panel signal processing board and LVDS transmitter.

Note 5 - 4 : All GND and VDD terminals should be used without any non-connected lines.

5-2) Connection between receiver and transmitter for LVDS

(1) Input data signal: 8bit

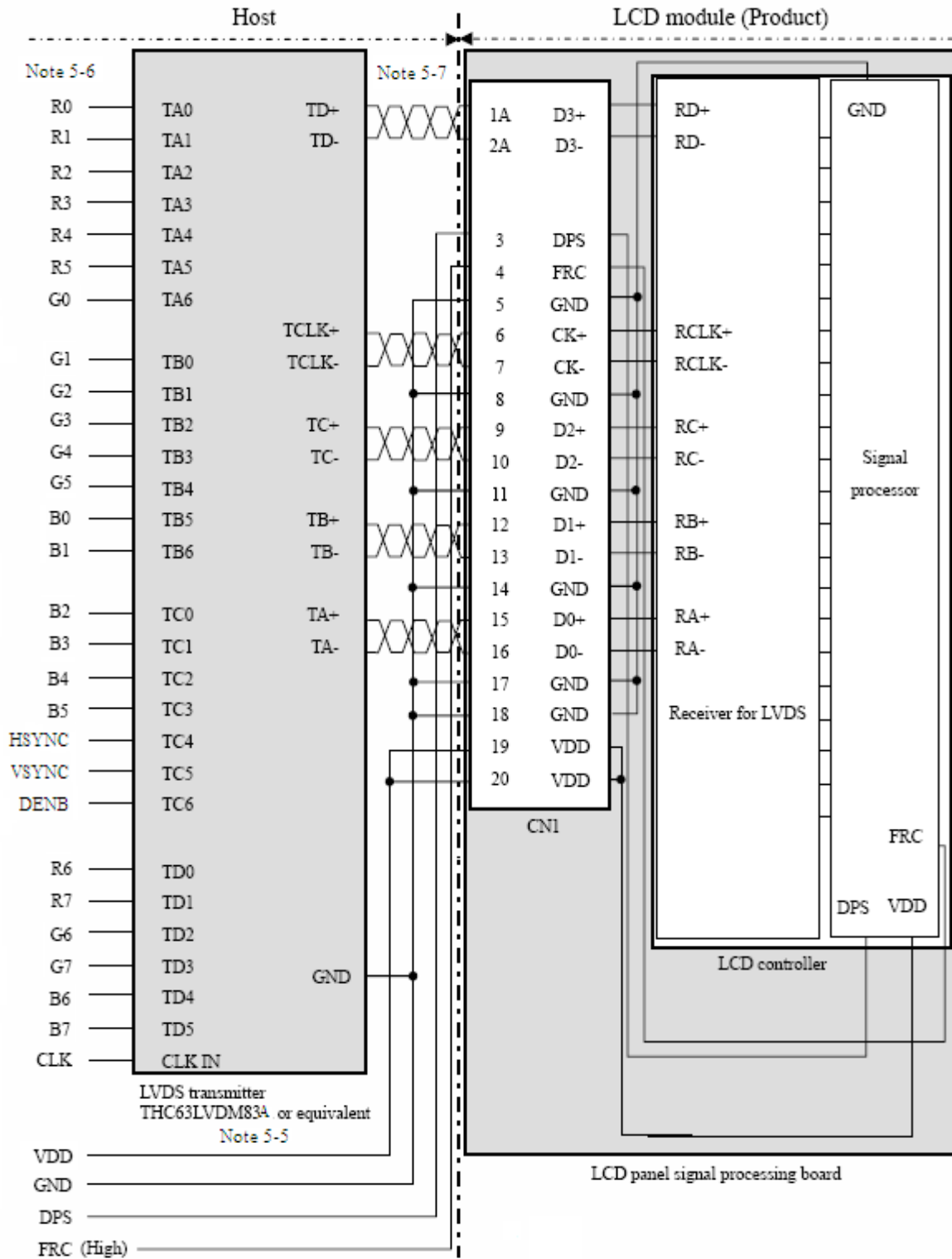

Note 5-5 : Recommended transmitter THC63LVDM83A (THine Electronics Inc.) or equivalent

Note 5-6 : LSB (Least Significant Bit) - R0, G0, B0 MSB (Most Significant Bit) - R7, G7, B7

Note 5-7 : Twist pair wires with 100Ω (Characteristic impedance) should be connected between LCD panel signal processing board and LVDS transmitter.

DENB input signal.

If customer wanted to off the DENB mode , you must keep the DENB always High or Low.

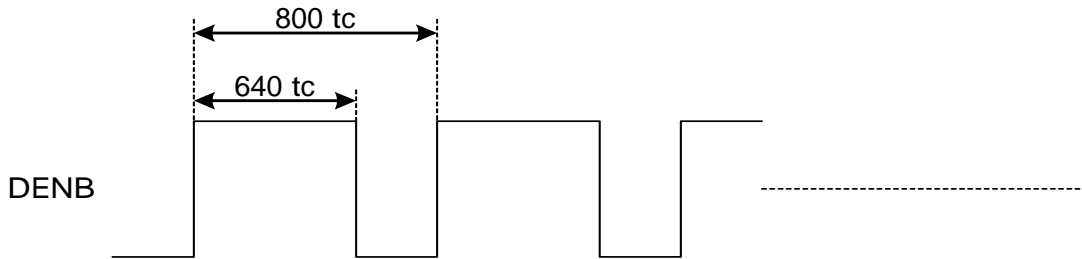

(tc: the period of sampling clock)

6. Absolute Maximum Ratings:

GND=0V, Ta=25

Parameters	Symbol	MIN.	MAX.	Unit	Remark
Supply Voltage	V _{DD}	-0.3	+4.0	V	
Input Signals Voltage	V _{IN}	-0.3	VDD+0.3	V	Note 6-1
Backlight Driving Voltage	V _L	-	2000	V	
Backlight Driving Frequency	F _L	25	80	KHz	

Note 6-1: LVDS signal.

7. Electrical Characteristics

7-1) Recommended Operating Conditions:

GND = 0V , Ta = 25

Item	Symbol	Min.	Typ.	Max.	Unit	Remark
Supply Voltage	V _{DD}	3.0	3.3	3.6	V	
Current Dissipation	I _{DD}	-	153	-	mA	Note 7-1
Total power consumption	P _{DD}	0.46	0.51	0.56	W	
LVDS Differential input high threshold	V _{TH}	-	-	100	mV	Note 7-2
LVDS Differential input low threshold	V _{TL}	-100	-	-	-	
Input voltage for DPS & FPC signal	High	V _{IH}	0.7VCC	-	VCC	V
	Low	V _{IL}	0	-	0.2VCC	V

Note 7-1 : To test the current dissipation of V_{DD}, using the “color bars” testing pattern shown as below.

1	2	3	4	5	6	7	8
---	---	---	---	---	---	---	---

1. White
2. Yellow
3. Cyan
4. Green
5. Magenta
6. Red
7. Blue
8. Black

I_{DD} current dissipation testing pattern

Note7-2 : Please refers to THC63LVDM83A specification by Thin Corporation. This LCD module conforms to LVDS standard.

7-2) Recommended Driving Condition for Back Light

Item	Symbol	Min.	Typ.	Max.	Unit	Remark
Lamp Current	I_{FL}	3	5	8	mA	5mA : 420 cd/m ² Note 7-3、 Note 7-5
Lamp Driving Frequency	F_L	25	40	80	KHz	
Lamp Voltage	V_L	-	510	-	Vrms	$I_{FL}=5mA$, Note 7-3
Starting Voltage (25) (Reference Value)	V_s	-	-	960	Vrms	Note 7-4
Starting Voltage (0) (Reference Value)	V_s	-	-	1030	Vrms	
Starting Voltage (-25) (Reference Value)	V_s	-	-	1120	Vrms	
Total power consumption (at $I_{FL}=5mA$)	-	-	5.1	8	W	Note 7-6

Note 7-3 : The back-light driving waveform should be as closed to sine-wave as possible.

In order to satisfy the quality of B/L , no matter use what kind of inverter , the each output lamp current must between Min. and Max. to avoid the abnormal display image caused by B/L.

Note 7-4 : The “Starting voltage ” means the minimum voltage of inverter to turn on the CCFL. and it should be applied to the lamp for more than 1 second to start up. Otherwise the lamp may not be turned on.

Note 7-5: Lamp current is measured with current meter for high frequency as shown below

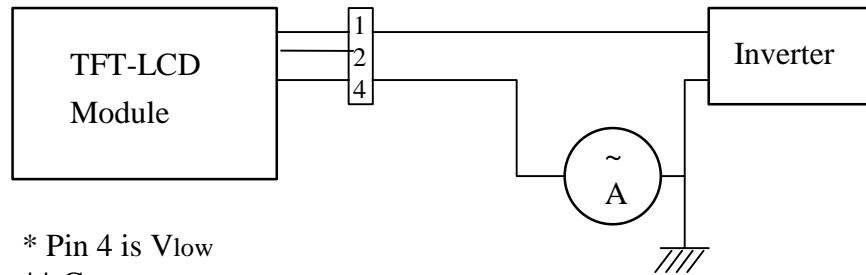

* Pin 4 is V_{low}
 ** Current meter :
 Yokogawa 2016-01

Lamp current dissipation testing configuration

Note 7-6 : Not including the efficiency of backlight DC/AC inverter

7-3) Backlight driving

Connector type : “BHR-04VS-1” of Japan Solder less Terminal MFG Co. LTD

PIN NO.	Symbol	Description	Remark
1	VL1	Input Voltage(High)	
2	VL2	Input Voltage(High)	
3	NC		
4	VL4	Input Voltage(Low)	

8. Pixel Arrangement

The LCD module pixel arrangement is the stripe.

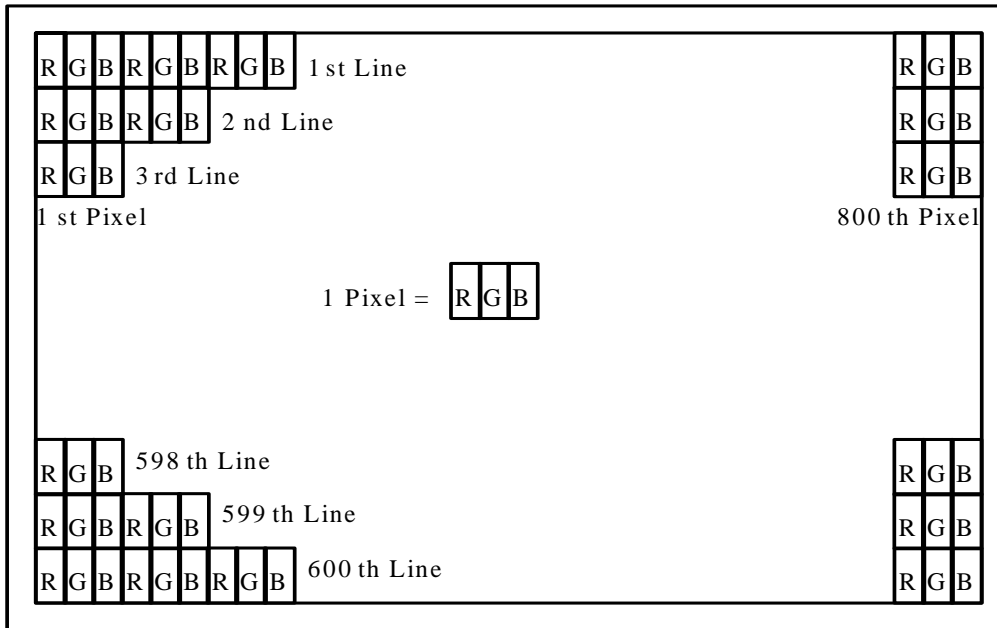

9. Display Colors and Input Data Signals

9-1) Combinations between input data signals and FRC signal

This product can display in equivalent to 16,777,216 colors in 256 gray scales and 262,144 colors in 64 gray scales by combination between input data signals and FRC signal. See following table.

Combination	Input data signals	CN1-Pin No.1 and 2	FRC terminal	Display colors	Remarks
①	8-bit	D3+/-	High	16,777,216	Note 9-1
②	6-bit	GND	Low or Open	262,144	Note 9-2

Note 9-1 : See " 9-2) 16,777,216 colors".

Note 9-2 : See " 9-3) 262,144 colors".

9-2) 16,777,216 colors

This product can display equivalent of 16,777,216 colors in 256 gray scales by combination ①

Display colors		Data signal (0: Low level, 1: High level)																							
		R7	R6	R5	R4	R3	R2	R1	R0	G7	G6	G5	G4	G3	G2	G1	G0	B7	B6	B5	B4	B3	B2	B1	B0
Basic Colors	Black	0	0	0	0	0	0	0	0	0	0	0	0	0	0	0	0	0	0	0	0	0	0	0	0
	Blue	0	0	0	0	0	0	0	0	0	0	0	0	0	0	0	0	1	1	1	1	1	1	1	1
	Red	1	1	1	1	1	1	1	1	0	0	0	0	0	0	0	0	0	0	0	0	0	0	0	0
	Magenta	1	1	1	1	1	1	1	1	0	0	0	0	0	0	0	0	1	1	1	1	1	1	1	1
	Green	0	0	0	0	0	0	0	0	1	1	1	1	1	1	1	1	0	0	0	0	0	0	0	0
	Cyan	0	0	0	0	0	0	0	0	1	1	1	1	1	1	1	1	1	1	1	1	1	1	1	1
	Yellow	1	1	1	1	1	1	1	1	1	1	1	1	1	1	1	1	0	0	0	0	0	0	0	0
	White	1	1	1	1	1	1	1	1	1	1	1	1	1	1	1	1	1	1	1	1	1	1	1	1
Red gray scale	Black	0	0	0	0	0	0	0	0	0	0	0	0	0	0	0	0	0	0	0	0	0	0	0	0
		0	0	0	0	0	0	0	1	0	0	0	0	0	0	0	0	0	0	0	0	0	0	0	0
	dark	0	0	0	0	0	0	1	0	0	0	0	0	0	0	0	0	0	0	0	0	0	0	0	0
	↑					:							:								:				
	↓					:							:								:				
	bright	1	1	1	1	1	1	0	1	0	0	0	0	0	0	0	0	0	0	0	0	0	0	0	0
Red	1	1	1	1	1	1	1	0	0	0	0	0	0	0	0	0	0	0	0	0	0	0	0	0	
Red	1	1	1	1	1	1	1	1	0	0	0	0	0	0	0	0	0	0	0	0	0	0	0	0	
Green gray scale	Black	0	0	0	0	0	0	0	0	0	0	0	0	0	0	0	0	0	0	0	0	0	0	0	0
		0	0	0	0	0	0	0	0	0	0	0	0	0	0	0	1	0	0	0	0	0	0	0	0
	dark	0	0	0	0	0	0	0	0	0	0	0	0	0	0	1	0	0	0	0	0	0	0	0	0
	↑					:							:								:				
	↓					:							:								:				
	bright	0	0	0	0	0	0	0	0	1	1	1	1	1	1	0	1	0	0	0	0	0	0	0	0
Green	0	0	0	0	0	0	0	0	1	1	1	1	1	1	1	1	0	0	0	0	0	0	0	0	
Blue gray scale	Black	0	0	0	0	0	0	0	0	0	0	0	0	0	0	0	0	0	0	0	0	0	0	0	0
		0	0	0	0	0	0	0	0	0	0	0	0	0	0	0	0	0	0	0	0	0	0	0	1
	dark	0	0	0	0	0	0	0	0	0	0	0	0	0	0	0	0	0	0	0	0	0	0	1	0
	↑					:							:								:				
	↓					:							:								:				
	bright	0	0	0	0	0	0	0	0	0	0	0	0	0	0	0	0	1	1	1	1	1	1	0	1
Blue	0	0	0	0	0	0	0	0	0	0	0	0	0	0	0	0	1	1	1	1	1	1	1	1	

9-3) 262,144 colors

This product can display equivalent of 262,144 colors in 64 gray scales by combination ②

Display colors		Data signal (0: Low level, 1: High level)																	
		R5	R4	R3	R2	R1	R0	G5	G4	G3	G2	G1	G0	B5	B4	B3	B2	B1	B0
Basic colors	Black	0	0	0	0	0	0	0	0	0	0	0	0	0	0	0	0	0	0
	Blue	0	0	0	0	0	0	0	0	0	0	0	0	1	1	1	1	1	1
	Red	1	1	1	1	1	1	0	0	0	0	0	0	0	0	0	0	0	0
	Magenta	1	1	1	1	1	1	0	0	0	0	0	0	1	1	1	1	1	1
	Green	0	0	0	0	0	0	1	1	1	1	1	1	0	0	0	0	0	0
	Cyan	0	0	0	0	0	0	1	1	1	1	1	1	1	1	1	1	1	1
	Yellow	1	1	1	1	1	1	1	1	1	1	1	1	0	0	0	0	0	0
	White	1	1	1	1	1	1	1	1	1	1	1	1	1	1	1	1	1	1
Red gray scale	Black	0	0	0	0	0	0	0	0	0	0	0	0	0	0	0	0	0	0
		0	0	0	0	0	1	0	0	0	0	0	0	0	0	0	0	0	0
	dark	0	0	0	0	1	0	0	0	0	0	0	0	0	0	0	0	0	0
	↑																		
	↓																		
	bright	1	1	1	1	0	1	0	0	0	0	0	0	0	0	0	0	0	0
Red	1	1	1	1	1	0	0	0	0	0	0	0	0	0	0	0	0	0	
Green gray scale	Black	0	0	0	0	0	0	0	0	0	0	0	0	0	0	0	0	0	0
		0	0	0	0	0	0	0	0	0	0	1	0	0	0	0	0	0	0
	dark	0	0	0	0	0	0	0	0	0	1	0	0	0	0	0	0	0	0
	↑																		
	↓																		
	bright	0	0	0	0	0	0	1	1	1	1	0	1	0	0	0	0	0	0
Green	0	0	0	0	0	0	1	1	1	1	1	0	0	0	0	0	0	0	
Blue gray scale	Black	0	0	0	0	0	0	0	0	0	0	0	0	0	0	0	0	0	0
		0	0	0	0	0	0	0	0	0	0	0	0	0	0	0	0	0	1
	dark	0	0	0	0	0	0	0	0	0	0	0	0	0	0	0	0	1	0
	↑																		
	↓																		
	bright	0	0	0	0	0	0	0	0	0	0	0	0	1	1	1	1	0	1
Blue	0	0	0	0	0	0	0	0	0	0	0	0	1	1	1	1	1	0	

9-4) DISPLAY POSITIONS

The following table is the coordinates per pixel (See " 9-5) SCANNING DIRECTIONS").

C (0, 0)						
R	G	B				
C(0, 0)	C(1, 0)	...	C(X, 0)	...	C(798, 0)	C(799, 0)
C(0, 1)	C(1, 1)	...	C(X, 1)	...	C(798, 1)	C(799, 1)
.
.
.
C(0, Y)	C(1, Y)	...	C(X, Y)	...	C(798, Y)	C(799, Y)
.
.
.
C(0, 598)	C(1, 598)	...	C(X, 598)	...	C(798, 598)	C(799, 598)
C(0, 599)	C(1, 599)	...	C(X, 599)	...	C(798, 599)	C(799, 599)

9-5) SCANNING DIRECTIONS

The following figures are seen from a front view. Also the arrow shows the direction of scan.

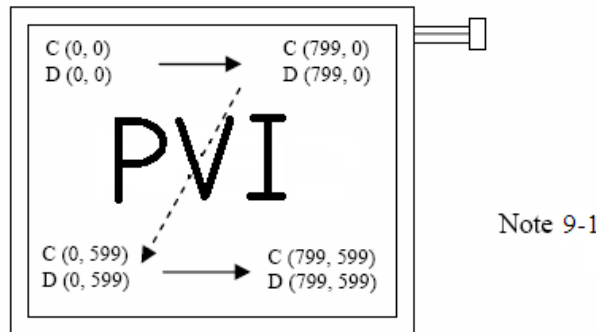

Figure1. Normal scan (DPS: Low or Open)

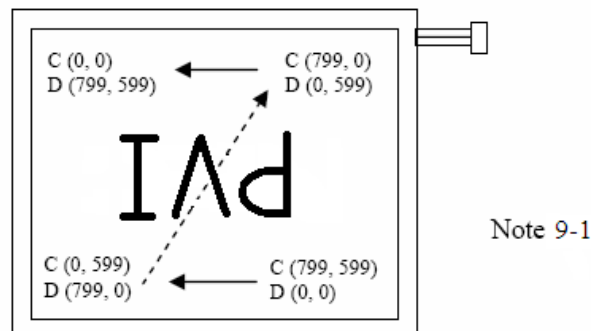

Figure2. Reverse scan (DPS: High)

Note1: Meaning of C (X, Y) and D (X, Y)

C (X, Y): The coordinates of the display position (See " 9-4) DISPLAY POSITIONS").

D (X, Y): The data number of input signal for LCD panel signal processing board

10. Input signal timing:

DENB pin have high priority than SYNC mode(HSVC+VSYNC). When IC only use SYNC pin, DENB pin have to connect to ground.

(A) Timing Specifications (DENB Mode):

Item	Symbol	Min.	Typ.	Max.	Unit	Remark
Frame Cycling Period	t1	604 X t3	628X t3	800 X t3	-	
		14	16.58	20	ms	
Vertical Display Period	t2	600 X t3	600 X t3	600 X t3	-	
Horizontal Scanning Time	t3	920 X t5	1056 X t5	1064 X t5	-	
		24	26.4	33	μ s	
Horizontal Display Period	t4	800 X t5	800 X t5	800 X t5	-	
Clock Cycle	t5	20	25.0	31.25	ns	
Clock High Level Time	t6	9.0	-	-	ns	
Clock Low Level Time	t7	9.0	-	-	ns	
Hold time	t8	4.0	-	-	ns	
Set-up time	t9	5.0	-	-	ns	

(B) Timing Specifications (SYNC Mode)

Item		Symbol	Min.	Typ.	Max.	Unit	Remark
HSYNC	Period	Hp	24	26.4	33	us	
			920	1056	1064	tc	
	Display period	Hdp	800	800	800	tc	
	Pulse width	Hpw	12	128	202	tc	
	Back-porch	Hbp	12	86	202	tc	
	Front-porch	Hfp	42	42	42	tc	
	Hpw+Hbp		214	214	214	tc	
	Hsync-CLK	Hhc	10	-	Tc-10	ns	
Vsync-Hsync	Hvh	0	0	200	tc		
VSYNC	Period (Frame cycling period)	Vp	14	16.58	20	ms	Note 1
			604	628	800	Hp	
	Display period	Vdp	600	600	600	Hp	
	Pulse width	Vpw	2	4	27	Hp	
	Back-porch	Vbp	0	23	25	Hp	
	Front-porch	Vfp	1	1	1	Hp	
	Vpw+Vbp		27	27	27	Hp	

Note 1: Frame cycling period is optimum in 16.58ms.(60HZ)

(C)Timing Chart:

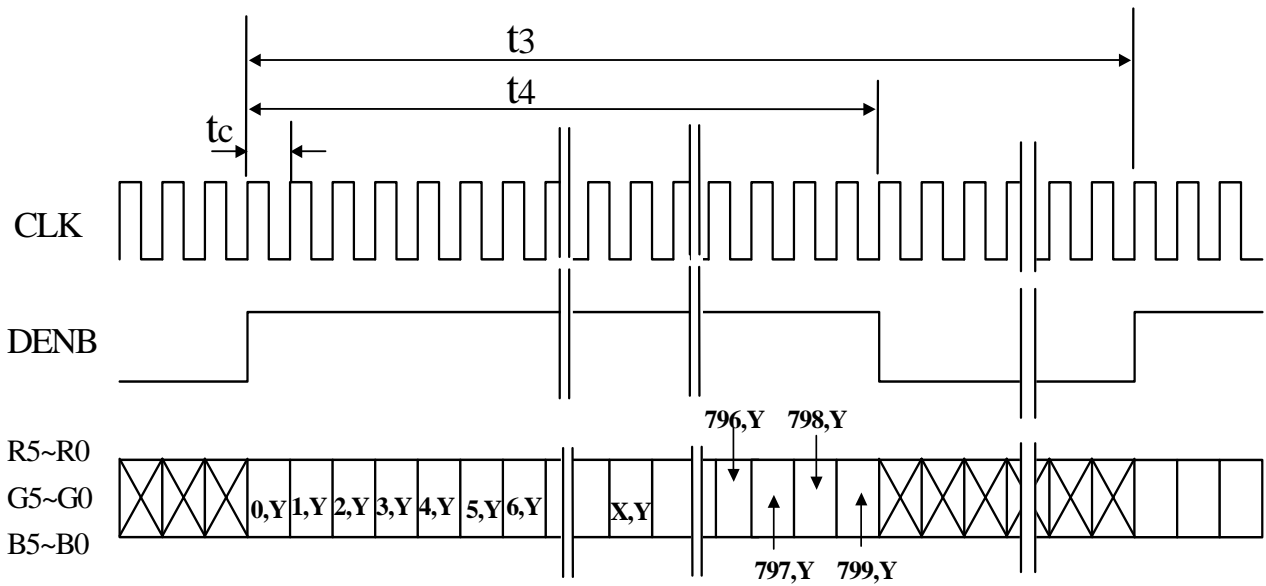
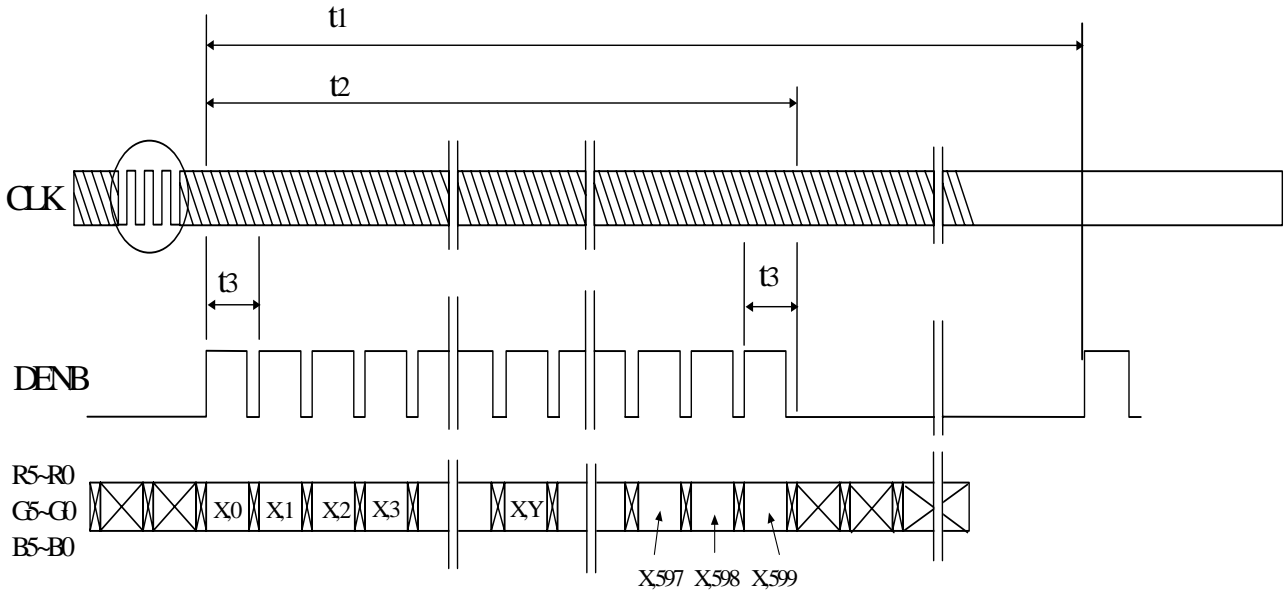

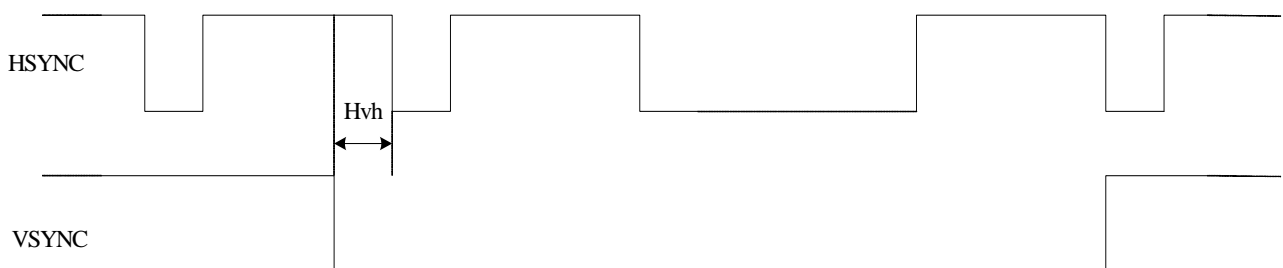
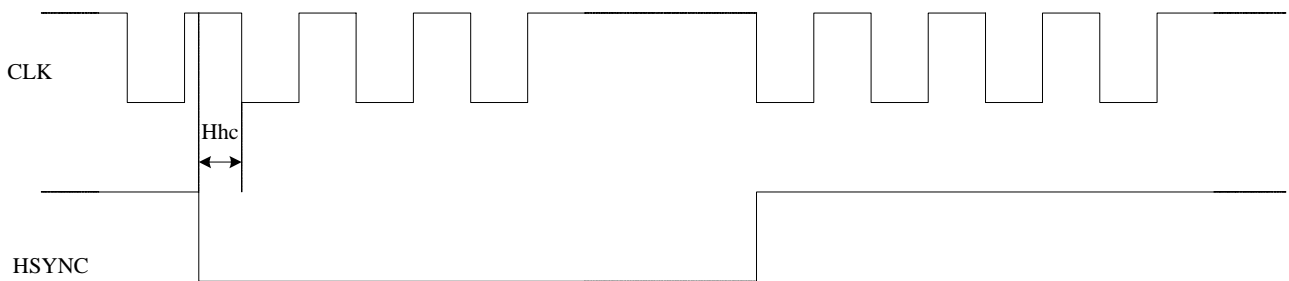
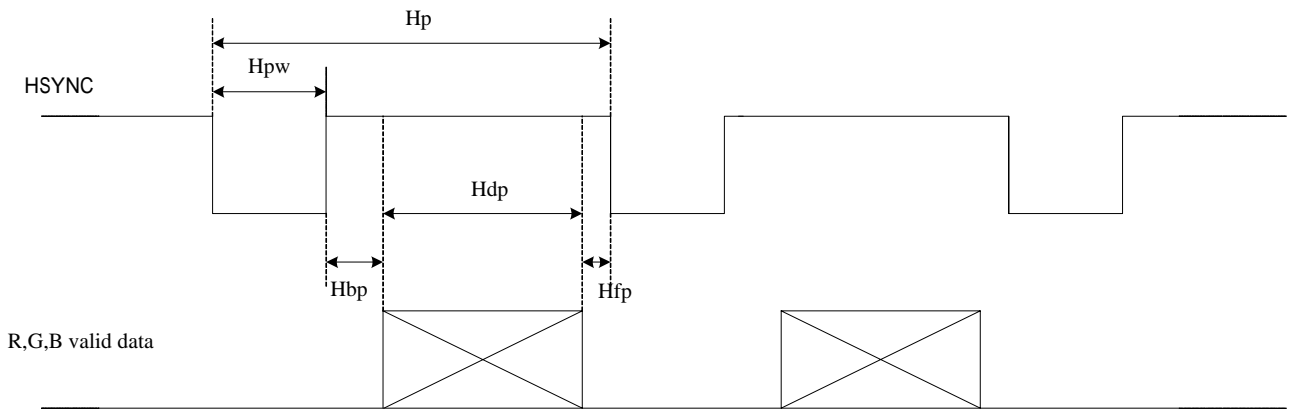

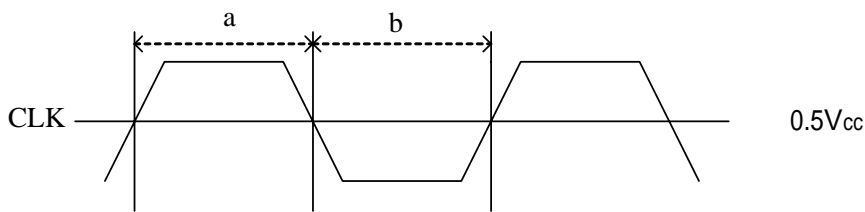
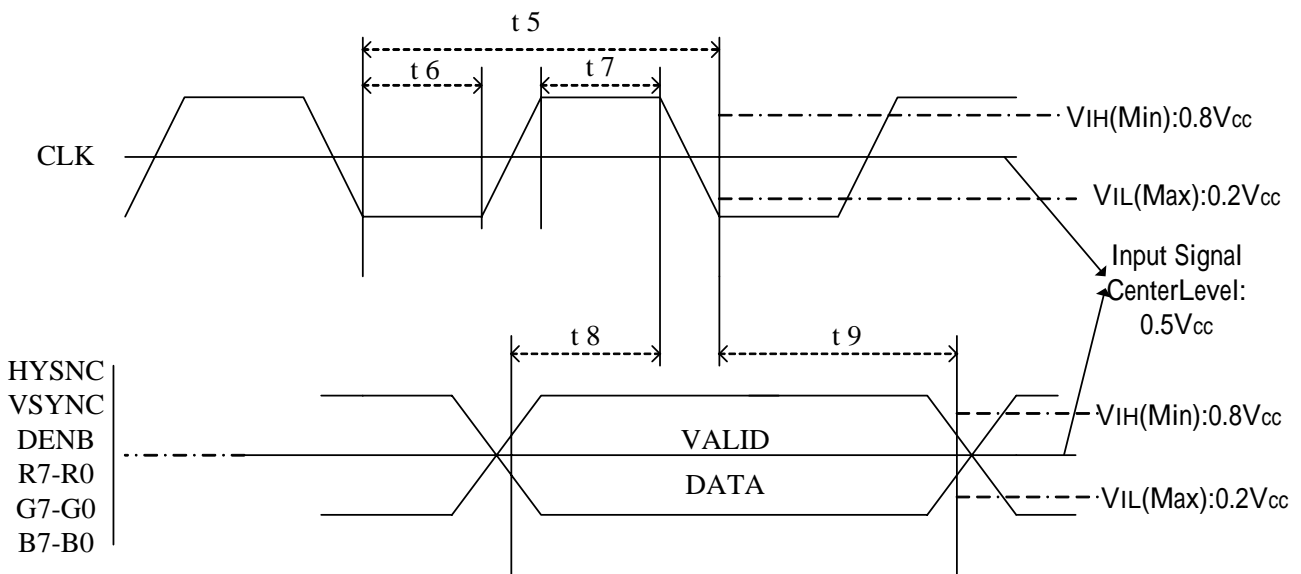
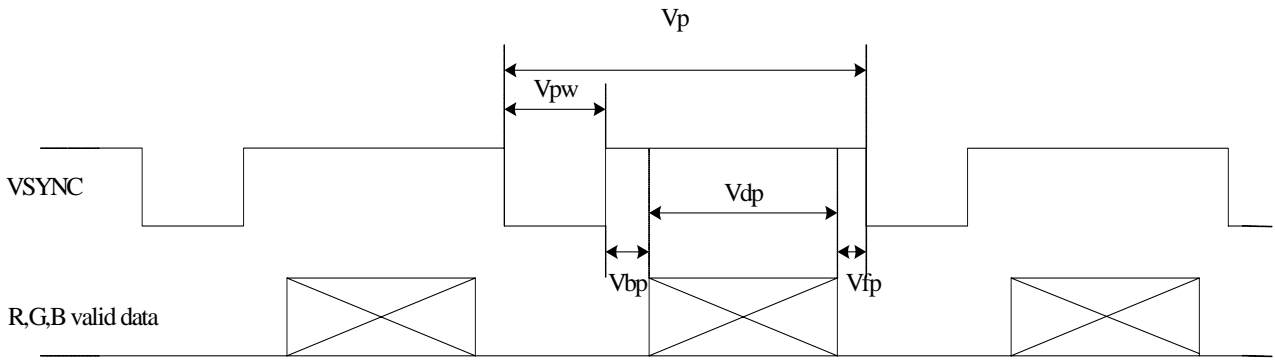

Duty (a , b) : $50 \pm 10\%$

11. Power On Sequence

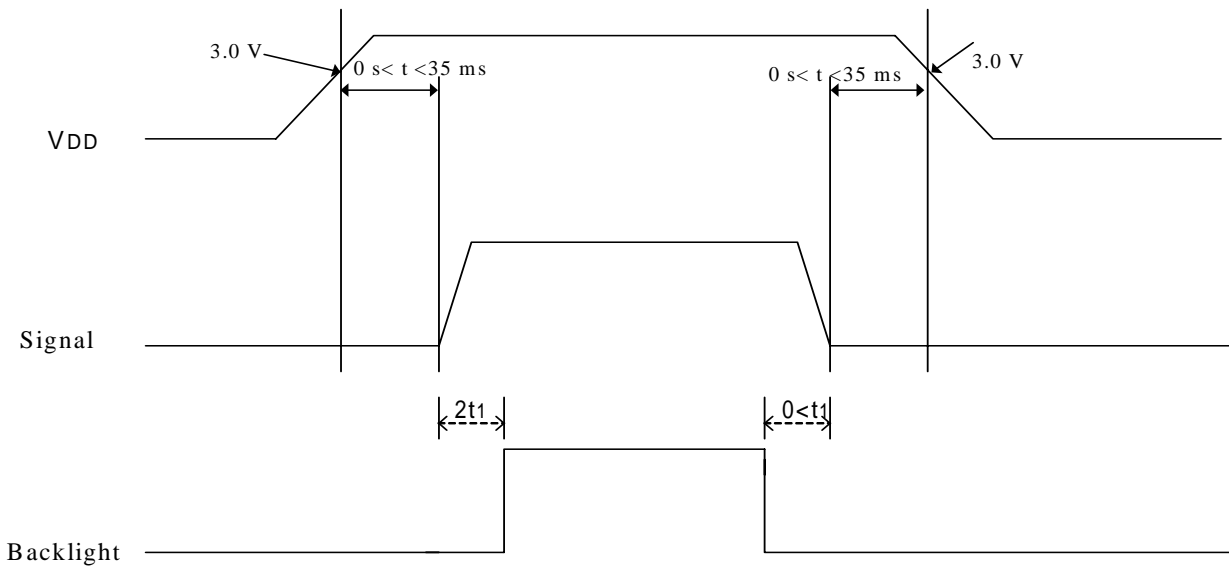

1. The supply voltage for input signals should be same as V_{DD} .
2. When the power is off , please keep whole signals (Hsync, Vsync, DENB, CLK, Data) low level or high impedance.

12. Optical Characteristics

12-1) Specification:

$T_a = 25$

Parameter	Symbol	Condition	MIN.	TYP.	MAX.	Unit	Remarks	
Viewing Angle	Horizontal	$CR \geq 10$	55	60	-	deg		
	Vertical		(to 6 o'clock)	45	50	-	deg	Note 12-1
			(to 12 o'clock)	30	35	-	deg	
Contrast Ratio	CR	Optimum direction	200	400	-	-	Note 12-2	
Response time	Rise	$=0^\circ$	-	15	30	ms	Note 12-4	
	Fall	$=0^\circ$	-	25	50	ms		
Luminance	L	$=0^\circ / =0^\circ$	390	420	-	cd/m^2	$I_{FL}=5mA$ Note 12-3	
Luminance Uniformity	U	-	75	80	-	%	Note 12-5	
White Chromaticity	x	$=0^\circ / =0^\circ$	0.29	0.32	0.35	-		
	y	$=0^\circ / =0^\circ$	0.32	0.35	0.38	-		
Lamp Life Time	-	25	50000	-	-	hrs	$I_{FL}=5mA$	
Cross Talk Ratio	CTK	-	-	-	3.5	%	Note 12-6	

All the optical measurement shall be executed 30 minutes after backlight being turn-on. The optical characteristics shall be measured in dark room (ambient illumination on panel surface less than 1 Lux). The measuring configuration shows as following figure.

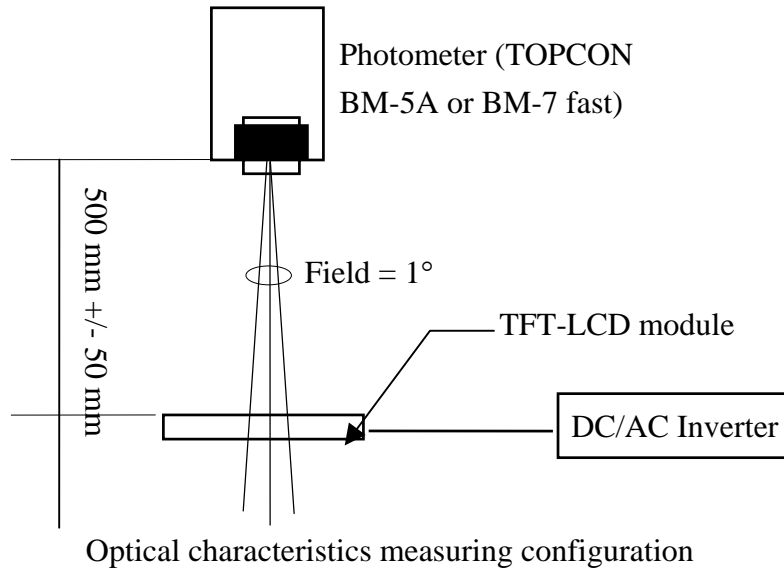

Note 12-1 : The definitions of viewing angles are as follows.

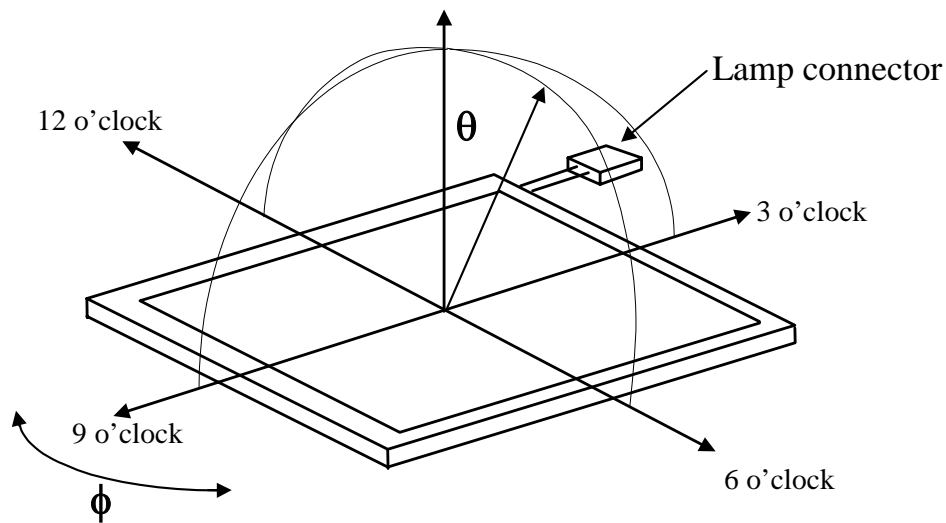

Note 12-2 : The definition of contrast ratio $CR = \frac{\text{Luminance at gray level 63}}{\text{Luminance at gray level 0}}$

Note 12-3 : The typical luminance value is measured at lamp current 5 mA. The max luminance value is measured at lamp current 8 mA.

Note 12-4: Definition of Response Time Tr and Tf:

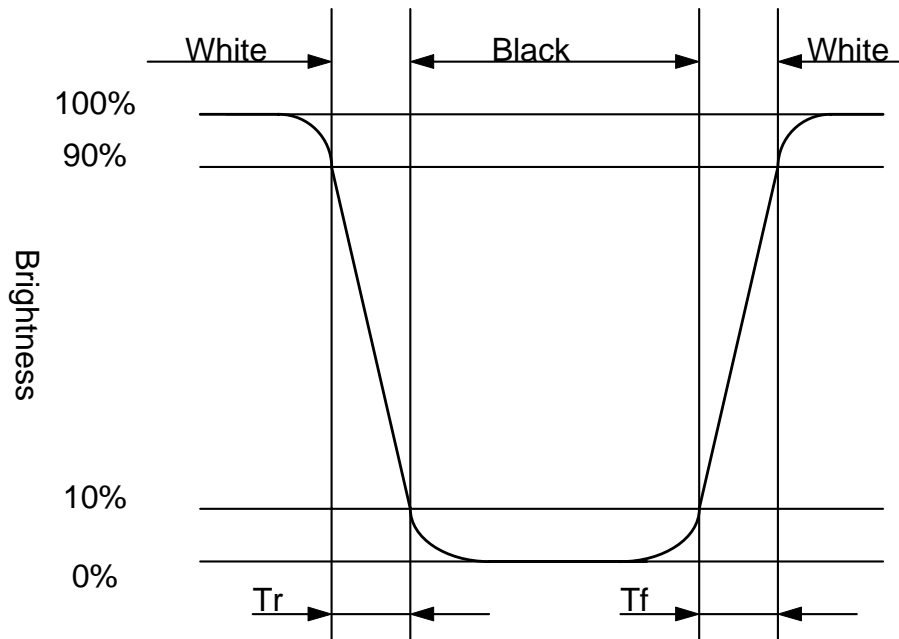

Note 12-5: The uniformity of LCD is defined as

$$U = \frac{\text{The Minimum Brightness of the 9 testing Points}}{\text{The Maximum Brightness of the 9 testing Points}}$$

Luminance meter : BM-5A or BM-7 fast(TOPCON)

Measurement distance : 500 mm +/- 50 mm

Ambient illumination : < 1 Lux

Measuring direction : Perpendicular to the surface of module

The test pattern is white (Gray Level 63).

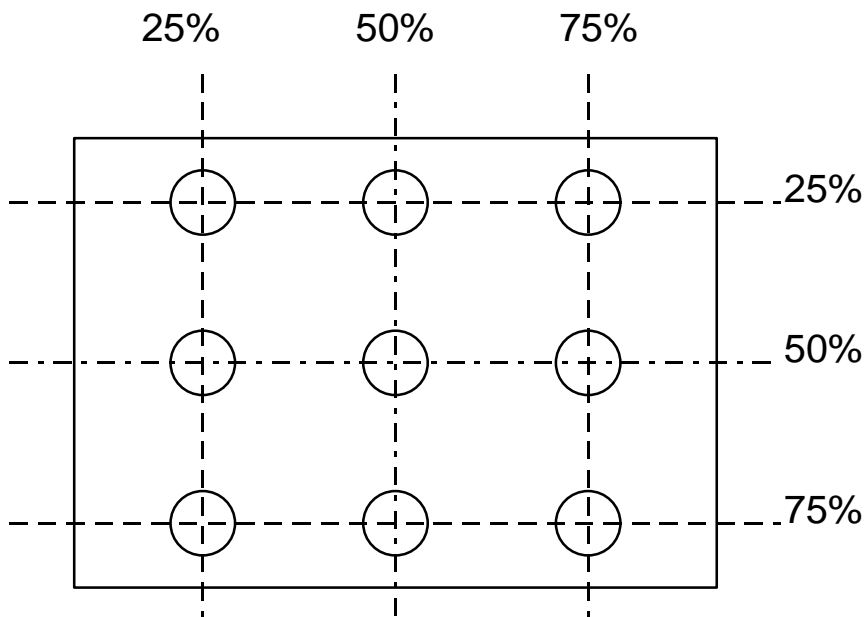

Note 12-6: Cross Talk (CTK) = $\frac{|YA-YB|}{YA} \times 100\%$

YA: Brightness of Pattern A

YB: Brightness of Pattern B

Luminance meter : BM 5A (TOPCON)

Measurement distance : 500 mm +/- 50 mm

Ambient illumination : < 1 Lux

Measuring direction : Perpendicular to the surface of module

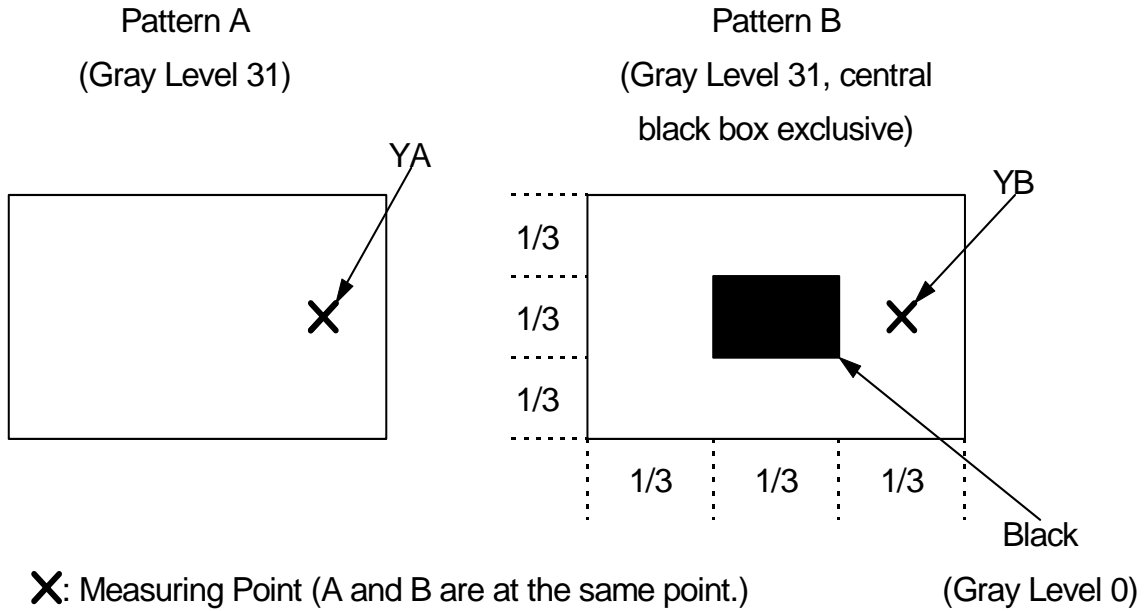

13. Handling Cautions

13-1) Mounting of module

4. Please power off the module when you connect the input/output connector.
- b) Please connect the ground pattern of the inverter circuit surely. If the connection is not perfect, some following problems may happen possibly.
 1. The noise from the backlight unit will increase.
4. The output from inverter circuit will be unstable.
4. In some cases a part of module will heat.
- c) Polarizer which is made of soft material and susceptible to flaw must be handled carefully.
- d) Protective film (Laminator) is applied on surface to protect it against scratches and diets. It is recommended to peel off the laminator before use and taking care of static electricity.

13-2) Precautions in mounting

- a) When metal part of the TFT-LCD module (shielding lid and rear case) is soiled, wipe it with soft dry cloth.
- b) Wipe off water drops or finger grease immediately. Long contact with water may cause discoloration or spots.
- c) TFT-LCD module uses glass which breaks or cracks easily if dropped or bumped on hard surface. Please handle with care.
- d) Since CMOS LSI is used in the module. So take care of static electricity and earth yourself when handling.

13-3) Adjusting module

- a) Adjusting volumes on the rear face of the module have been set optimally before shipment.
- b) Therefore, do not change any adjusted values. If adjusted values are changed, the specifications described may not be satisfied.

13-4) Others

- a) Do not expose the module to direct sunlight or intensive ultraviolet rays for many hours.
- b) Store the module at a room temperature place.
- c) The voltage of beginning electric discharge may over the normal voltage because of leakage current from approach conductor by to draw lump read lead line around.
- d) If LCD panel breaks, it is possibly that the liquid crystal escapes from the panel. Avoid putting it into eyes or mouth. When liquid crystal sticks on hands, clothes or feet. Wash it out immediately with soap.
- e) Observe all other precautionary requirements in handling general electronic components.
- f) Please adjust the voltage of common electrode as material of attachment by 1 module.

14. Reliability Test

No	Test Item	Test Condition
1	High Temperature Storage Test	Ta = +80 , 240 hrs
2	Low Temperature Storage Test	Ta = -25 , 240 hrs
3	High Temperature Operation Test	Ta =+80 , 240 hrs
4	Low Temperature Operation Test	Ta = -25 , 240 hrs
5	High Temperature & High Humidity Operation Test	Ta = +60 , 90%RH, 240 hrs (No Condensation)
6	Thermal Cycling Test (non-operating)	-20 \leftrightarrow +80 , 100 Cycles 30 min 30 min
7	Vibration Test (non-operating)	Frequency : 10 ~ 57 Hz, Amplitude : 0.15 mm 58~500Hz, 1G Sweep time : 11 min ; Test Period : 3 hrs (1 hr for each direction of X, Y, Z)
8	Shock Test (non-operating)	80G, 6ms, X,Y, Z 1 times for each direction
9	Electron Static Discharge	C=150pF,R=330 Contact= \pm 8KV , Air= \pm 15KV 10 times/terminal

Ta: ambient temperature

Note: The protective film must be removed before temperature test

[Criteria]

In the standard conditions, there is not display function NG issue occurred. (Including: line defect, no image). All the cosmetic specification is judged before the reliability stress.

15.Packing

ZONE	REV.	DOCUMENT NO.	DESCRIPTION	DATE	REV.BY																									
<p>NOTE:</p> <p>1.Q'TY: 20 pcs panel/carton. 2.Dimension: 530*295*230mm 3.Weight: 10.00 Kg</p>																														
<table border="1" style="width:100%; border-collapse: collapse;"> <thead> <tr> <th>ITEM</th> <th>PART NO.</th> <th>DESCRIPTION</th> <th>QTY</th> <th>REMARK</th> </tr> </thead> <tbody> <tr> <td>4</td> <td>50-0100111</td> <td>CARTON</td> <td>1</td> <td></td> </tr> <tr> <td>3</td> <td>50-0500281</td> <td>抗靜電袋</td> <td>20</td> <td>抗靜電</td> </tr> <tr> <td>2</td> <td></td> <td>PD080SL1</td> <td>20</td> <td></td> </tr> <tr> <td>1</td> <td>50-0301691</td> <td>瓦楞隔板緩衝材</td> <td>1</td> <td>上蓋+底座</td> </tr> </tbody> </table>						ITEM	PART NO.	DESCRIPTION	QTY	REMARK	4	50-0100111	CARTON	1		3	50-0500281	抗靜電袋	20	抗靜電	2		PD080SL1	20		1	50-0301691	瓦楞隔板緩衝材	1	上蓋+底座
ITEM	PART NO.	DESCRIPTION	QTY	REMARK																										
4	50-0100111	CARTON	1																											
3	50-0500281	抗靜電袋	20	抗靜電																										
2		PD080SL1	20																											
1	50-0301691	瓦楞隔板緩衝材	1	上蓋+底座																										
MTL.SPEC.		UNSPECIFIED TOL'S		REMARK																										
		ANGLE																												
		ROUGHNESS																												
APPROVE	Franks	'06.12.12	SCALE	UNIT	SHEET																									
CHECK	Franks	'06.12.12			1 OF 1																									
DRAWN	Ethanc	'06.12.12	MTL.NO.		DWG FILE:																									
元太科技工業股份有限公司 Prime View International Co., Ltd.					DWG.TITLE PD080SL1 Packing Draw																									
				REV. 01	A4 SIZE																									