



YENYO

HFR15A12

Hyperfast Recovery Rectifier

Features

- ★ Fast switching for high efficiency
- ★ Low noise
- ★ Low reverse leakage current
- ★ High voltage super FRD
- ★ PFC application

Mechanical Data

- ★ Case: Molded plastic TO-220AC
- ★ Epoxy: UL 94V-0 rate flame retardant ,
- ★ Terminals: Solderable per MIL-STD-202 method 208
- ★ Mounting position: Any
- ★ Weight: 2.07 grams

**Voltage Range 1200 V
Current 15.0 Ampere**

TO-220AC

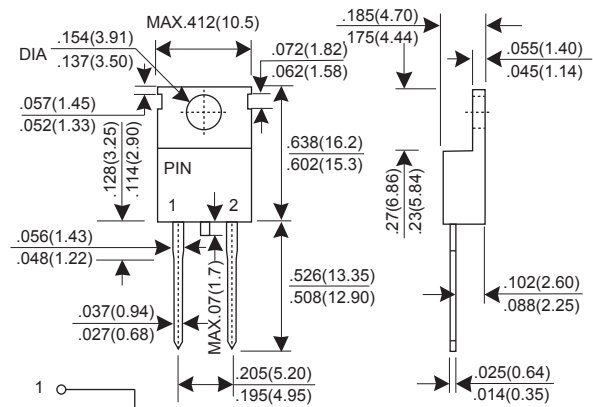

Dimensions in inches and (millimeters)

MAXIMUM RATINGS AND ELECTRICAL CHARACTERISTICS

Rating at 25°C ambient temperature unless otherwise specified.

Single phase, half wave, 60Hz, resistive or inductive load.

For capacitive load, derate current by 20%.

CHARACTERISTIC	SYMBOL	HFR15A12			UNIT
		Min.	Typ.	Max.	
Recurrent Peak Reverse Voltage	V _{RRM}	-	-	1200	V
RMS Voltage	V _{RMS}	-	-	840	V
DC Blocking Voltage	V _{DC}	-	-	1200	V
Average Forward Rectified Current T _c =140°C	I _{F(AV)}	-	-	15.0	A
Peak Forward Surge Current, 8.3ms single Half sine-wave superimposed on rated load (JEDEC method)	I _{FSM}	-	-	200	A
Instantaneous Forward Voltage @15A(25°C) @15A(150°C)	V _F	-	-	3.2 2.8	V
DC Reverse Current @T _J =25°C At Rated DC Blocking Voltage @T _J =150°C	I _R	-	-	100 500	uA
Maximum Reverse Recovery Time (Note 1)	T _{rr}	-	-	45	nS
Maximum Reverse Recovery Time (Note 2)	T _{rr}	-	-	75	nS
Typical junction Capacitance (Note 3)	C _J	-	55	-	pF
Typical Thermal Resistance (Note 4)	R _{θJC}	-	-	1.5	°CW
Operating Junction and Storage Temperature Range	T _J , T _{STG}	-65	-	175	°C

NOTES : (1) Reverse recovery test conditions I_F = 0.5A , I_R = 1A , I_{rr} = 0.25A

(2) Reverse recovery test conditions I_F = 15A, dI_F/dt = 100A/us.

(3) Junction Capacitance test conditions : V_R = 10V, I_F = 0A.

(4) Thermal Resistance junction to case.

RATINGS AND CHARACTERISTIC CURVES HFR15A12

FIG.1 - FORWARD CURRENT DERATING CURVE

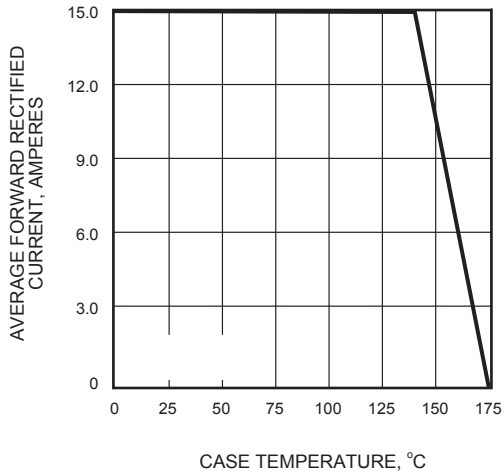

FIG.2 - MAXIMUM NON-REPETITIVE PEAK FORWARD SURGE CURRENT

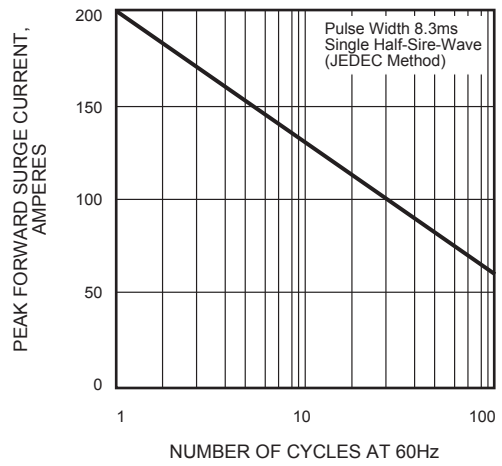

FIG.3 - TYPICAL INSTANTANEOUS FORWARD CHARACTERISTICS

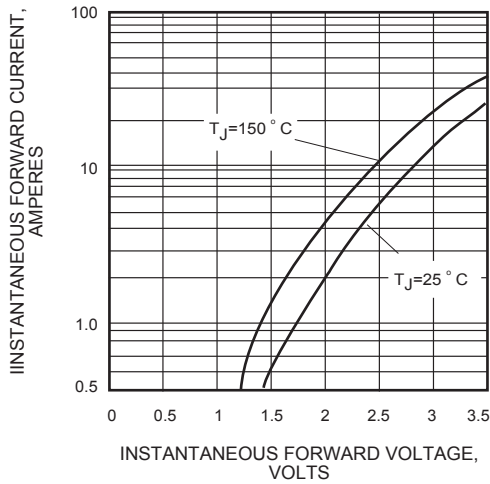

FIG.4 - TYPICAL REVERSE CHARACTERISTICS

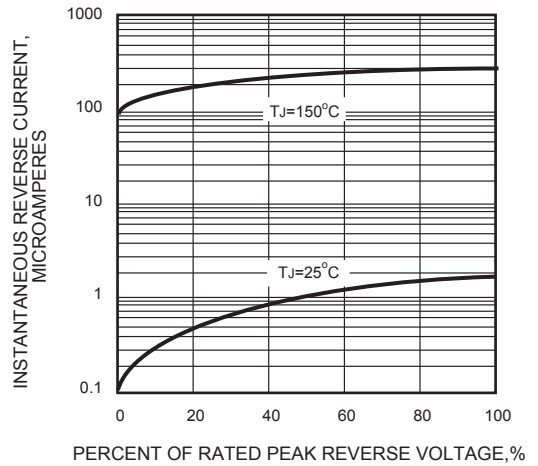

FIG.5 - t_{rr} , t_a AND t_b CURVES vs FORWARD CURRENT

