



Product Description: T546HW01 TFT-LCD PANEL	
AUO Model Name: T546HW01 V1	
Customer Part No. / Project Name:	
Customer Signature	AU Optronics Corp.
	Approved By: PM Director / Frank Hsu <u>Frank Hsu.</u>
	Reviewed By: RD Director / Eugene CC Chen
	Reviewed By: Project Leader / Jason Liu
	Prepared By: PM / Momo Lee
Note	



Document Version: 2.5

Date: 2009/11/19

Product Functional Specification

**55" Full HD Color TFT-LCD Module
Model Name: T546HW01 V1**

**() Preliminary Specification
(* Final Specification)**



Contents

No	
	CONTENTS
	RECORD OF REVISIONS
1	GENERAL DESCRIPTION
2	ABSOLUTE MAXIMUM RATINGS
3	ELECTRICAL SPECIFICATION
3-1	ELECTRICAL CHARACTERISTICS
3-2	INTERFACE CONNECTOR
3-3	SIGNAL TIMING SPECIFICATION
3-4	SIGNAL TIMING WAVEFORM
3-5	COLOR INPUT DATA REFERENCE
3-6	POWER SEQUENCE
3-7	BACK LIGHT POWER SPECIFICATION
4	OPTICAL SPECIFICATION
5	MECHANICAL CHARACTERISTICS
6	RELIABILITY
7	INTERNATIONAL STANDARD
8	PACKING
9	PRECAUTION



Record of Revision

Version	Date	Page.	Old Description	New Description	Remark
0.0	2009/05/22		First release	N/A	N/A
1.0	2009/6/3			Add pin assignment and Power sequence.	
2.0	2009/8/3			LVDS Connector updated	
2.1	2009/8/4			Updated 2D drawing.	
2.2	2009/8/19	9		LVDS_SEL definition	
		15		Remove Power Seq. t2 Max value.	
		15		Remove Power Seq. t5 Max value.	
		25		Add Reliability test item	
2.3	2009/10/29	7		Fill with TBD value of Electrical Specification	
		12		Add 100Hz Timing table	
		15		Modify BLU Power sequence	
		18		Modify Internal PWM Dimming Ratio to 5%~100% and add notification.	
2.4	2009/11/09	7		Update IDD(typ.)=0.76 A	
		9,10		Update Pin assignment description	
		13		Update Timing waveforms	
		15		Modify T2 Max. Values	
		27	Drawing 5Pcs	6Pcs	
		28	Total weight 110Kg	Total weight 133Kg	



1. General Description

This specification applies to the 55 inch Color TFT-LCD Module T546HW01 V1. This LCD module has a TFT active matrix type liquid crystal panel 1920x1080 pixels, and diagonal size of 55 inch. This module supports Full HD mode (Non-interlace) with 120Hz frame rate.

Each pixel is divided into Red, Green and Blue sub-pixels or dots which are arranged in vertical stripes. Gray scale or the brightness of the sub-pixel color is determined with a 10-bit gray scale signal for each dot.

The T546HW01 V1 has been designed to apply the 10-bit 4 channel LVDS interface method. It is intended to support displays where high brightness, EBU Gamut (72% NTSC), wide viewing angle, and high color depth are very important.

The T546HW01 V1 backlight unit is using inverter.

* General Information

Items	Specification	Unit	Note
Active Screen Size	55	inches	Diagonal
Display Area	1209.6(H) x 680.4(V)	mm	
Outline Dimension	1286 (H) x 745(V) x 60(D)	mm	With Inverter cover
Driver Element	a-Si TFT active matrix		
Display Colors	1073.7M (8bit+FRC),	Colors	
Color Gamut	72	%	NTSC
Number of Pixels	1920 x 1080	Pixel	
Pixel Arrangement	RGB vertical stripe		
Pixel Pitch	0.63	mm	
Display Mode	Normally Black		
Surface Treatment	Haze 11%		
RoHS	RoHS compliance		



2. Absolute Maximum Ratings

The followings are maximum values which, if exceeded, may cause faulty operation or damage to the unit

Item	Symbol	Min.	Max	Unit	Note
Logic/LCD Drive Voltage	V_{DD}	-0.3	14.0	V_{DC}	1
Input Voltage of Signal	V_{IN}	-0.3	3.6	V_{DC}	1
Operating Temperature	T_{OP}	0	+50	$^{\circ}C$	2
Operating Humidity	H_{OP}	10	90	%RH	2
Storage Temperature	T_{ST}	-20	+60	$^{\circ}C$	2
Storage Humidity	H_{ST}	10	90	%RH	2
Panel Surface Temperature	T_{SUR}	--	+65	$^{\circ}C$	2
Shock (non-operation)	$\pm x, \pm y$	--	50	G	3
Shock (non-operation)	$\pm z$	--	50	G	3
Vibration (non-operation)		--	1.5	G	4

Note 1: Duration = 50ms

Note 2: Maximum Wet-Bulb should be $39^{\circ}C$ and no condensation. The relative humidity must not exceed 90% non-condensing at temperatures of $40^{\circ}C$ or less. At temperatures greater than $40^{\circ}C$, the wet bulb temperature must not exceed $39^{\circ}C$.

Note 3: Sine wave, 11ms, direction: $\pm x, \pm y, \pm z$ (one time each direction)

Note 4: Wave form: random, vibration level: 1.5G RMS, Bandwidth: 10--300Hz
Duration: X, Y, Z 30min (one time each direction)

Note 5: Surface temperature is measured at $50^{\circ}C$ Dry condition

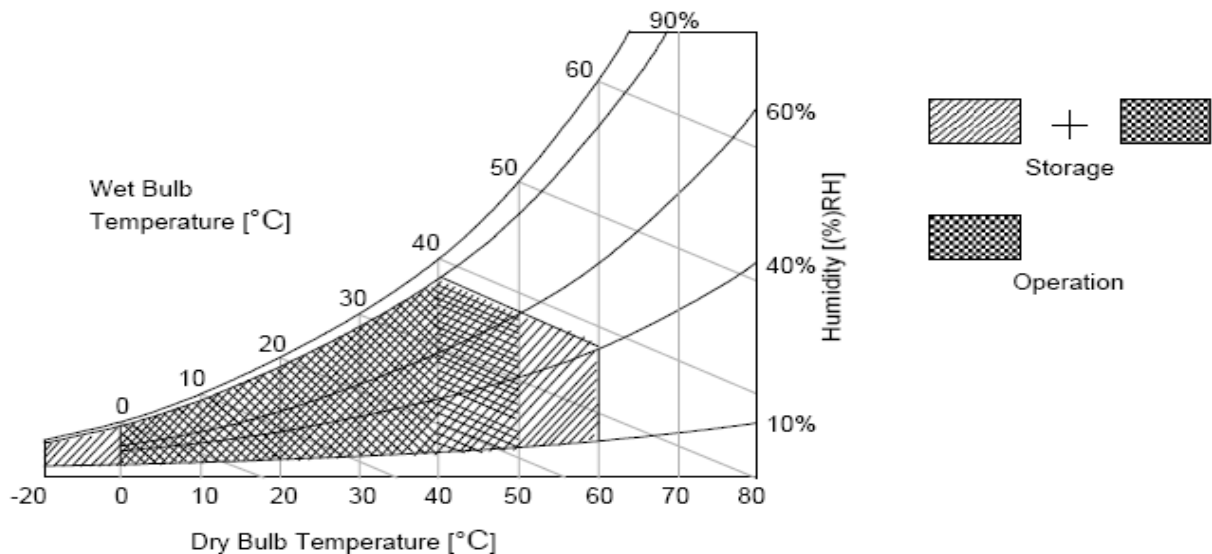



3. Electrical Specification

The T546HW01 V1 requires two power inputs. One is employed to power the LCD electronics and to drive the TFT array and liquid crystal. The second input, which powers the CCFL, is typically generated by an integrate power (I/P) system.

3.1 Electrical Characteristics

Parameter		Symbol	Value			Unit	Note
			Min.	Typ.	Max		
Power Supply Input Voltage		V_{DD}	10.8	12.0	13.2	V_{DC}	
Power Supply Input Current		I_{DD}	--	0.76		A	1
Power Consumption		P_C	--	9.12		Watt	1
Inrush Current		I_{RUSH}	--	--	4	A	5
LVDS Interface	Differential Input High Threshold Voltage	V_{TH}	--	--	+100	mV_{DC}	4
	Differential Input Low Threshold Voltage	V_{TL}	-100	--	--	mV_{DC}	4
	Common Input Voltage	V_{CIM}	-1.10	1.25	1.40	V_{DC}	
CMOS Interface	Input High Threshold Voltage	V_{IH} (High)	2.4	--	3.3	V_{DC}	
	Input Low Threshold Voltage	V_{IL} (Low)	0	--	0.7	V_{DC}	
Backlight Power Consumption (ref.)		P_{BL}	--	(260)	--	Watt	2
Life Time			50000	--	--	Hours	3

Note:

1. $V_{DD}=12.0V$, $f_V=60Hz$, $f_{CLK}=81.5Mhz$, $25^\circ C$, V_{DD} duration time= $400\mu s$, test pattern: white pattern
2. The backlight power consumption shown above is tested by lamp current $I_L=9.0mA$.
3. $V_{CIM}=1.25V$

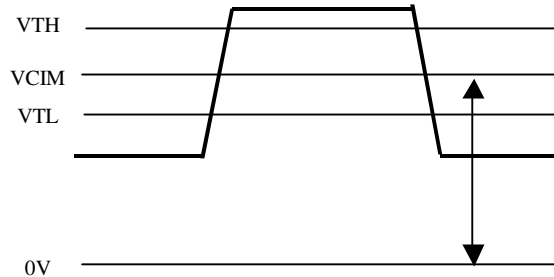
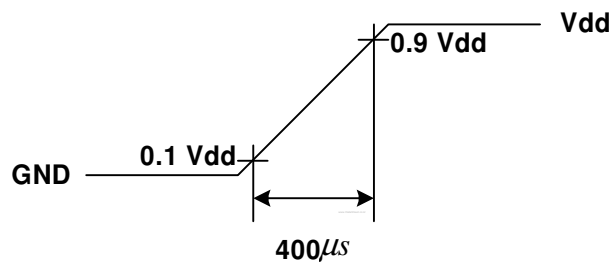

Figure: LVDS Differential Voltage

4. Measurement condition: rising time= $400\mu s$



5. Specified values are for a single lamp only which is aligned horizontally. The lifetime is defined as the time which luminance of the lamp is 50% compared to its original value.
[Operating condition: Continuous operating at $T_a = 25\pm 2^\circ C$]
6. The performance of the Lamp in LCD panel, for example life time or brightness, is extremely influenced by the characteristics of balanced board and I/P board. All the parameters should be carefully designed as not to produce too much leakage current from high-voltage output. While you design or order the balance board, please make sure unwanted lighting caused by the mismatch of the lamp and the balanced board (no lighting, flicker, etc) never occurs. After confirmation, the LCD panel should be operated in the same condition as installed in your instrument
7. Do not attach a conducting tape to lamp connecting wire. If the lamp wire attach to conducting tape, TFT-LCD Module have a low luminance and the inverter has abnormal action because leakage current occurs between lamp wire and conducting tape.
8. The relative humidity must not exceed 80% non-condensing at temperatures of $40^\circ C$ or less. At temperatures greater than $40^\circ C$, the wet bulb temperature must not exceed $39^\circ C$. When operate at low temperatures, the brightness of CCFL will drop and the life time of CCFL will be reduced.



3.2 Interface Connections

LCD connector: 187059-51221 (Manufactured by P-TWO); 187060-41221 (Manufactured by P-TWO)

Note 1: All GND (ground) pins should be connected together and should also be connected to the LCD's metal frame.

Note 2: All V_{DD} (power input) pins should be connected together.

Note 3: All NC (no connection) pins should be open without voltage input.

ICON 51P

PIN	Symbol	Description	PIN	Symbol	Description
1	Reserved	AUO Internal Use Only	26	GND	Ground
2	Reserved	AUO Internal Use Only	27	GND	Ground
3	NC	No connection	28	CH2_0-	LVDS Channel 2, Signal 0-
4	Reserved	AUO Internal Use Only	29	CH2_0+	LVDS Channel 2, Signal 0+
5	NC	No connection	30	CH2_1-	LVDS Channel 2, Signal 1-
6	NC	No connection	31	CH2_1+	LVDS Channel 2, Signal 1+
7	LVDS_SEL	Open/High(3.3V) for NS, Low(GND) for JEIDA	32	CH2_2-	LVDS Channel 2, Signal 2-
8	NC	No connection	33	CH2_2+	LVDS Channel 2, Signal 2+
9	NC	No connection	34	GND	Ground
10	NC	No connection	35	CH2_CLK-	LVDS Channel 2, Clock -
11	GND	Ground	36	CH2_CLK+	LVDS Channel 2, Clock +
12	CH1_0-	LVDS Channel 1, Signal 0-	37	GND	Ground
13	CH1_0+	LVDS Channel 1, Signal 0+	38	CH2_3-	LVDS Channel 2, Signal 3-
14	CH1_1-	LVDS Channel 1, Signal 1-	39	CH2_3+	LVDS Channel 2, Signal 3+
15	CH1_1+	LVDS Channel 1, Signal 1+	40	CH2_4-	LVDS Channel 2, Signal 4-
16	CH1_2-	LVDS Channel 1, Signal 2-	41	CH2_4+	LVDS Channel 2, Signal 4+
17	CH1_2+	LVDS Channel 1, Signal 2+	42	GND	Ground
18	GND	Ground	43	GND	Ground
19	CH1_CLK-	LVDS Channel 1, Clock -	44	GND	Ground
20	CH1_CLK+	LVDS Channel 1, Clock +	45	GND	Ground
21	GND	Ground	46	GND	Ground
22	CH1_3-	LVDS Channel 1, Signal 3-	47	NC	No connection
23	CH1_3+	LVDS Channel 1, Signal 3+	48	V_{DD}	Power Supply, +12V DC Regulated
24	CH1_4-	LVDS Channel 1, Signal 4-	49	V_{DD}	Power Supply, +12V DC Regulated
25	CH1_4+	LVDS Channel 1, Signal 4+	50	V_{DD}	Power Supply, +12V DC Regulated
			51	V_{DD}	Power Supply, +12V DC Regulated

ICON 41P



PIN	Symbol	Description	PIN	Symbol	Description
1	NC	No connection	21	CH3_3+	LVDS Channel 3, Signal 3+
2	Reserved	AUO Internal Use Only	22	CH3_4-	LVDS Channel 3, Signal 4-
3	Reserved	AUO Internal Use Only	23	CH3_4+	LVDS Channel 3, Signal 4+
4	NC	No connection	24	GND	Ground
5	Reserved	AUO Internal Use Only	25	GND	Ground
6	Reserved	AUO Internal Use Only	26	CH4_0-	LVDS Channel 4, Signal 0-
7	NC	No connection	27	CH4_0+	LVDS Channel 4, Signal 0+
8	NC	No connection	28	CH4_1-	LVDS Channel 4, Signal 1-
9	GND	Ground	29	CH4_1+	LVDS Channel 4, Signal 1+
10	CH3_0-	LVDS Channel 3, Signal 0-	30	CH4_2-	LVDS Channel 4, Signal 2-
11	CH3_0+	LVDS Channel 3, Signal 0+	31	CH4_2+	LVDS Channel 4, Signal 2+
12	CH3_1-	LVDS Channel 3, Signal 1-	32	GND	Ground
13	CH3_1+	LVDS Channel 3, Signal 1+	33	CH4_CLK-	LVDS Channel 4, Clock -
14	CH3_2-	LVDS Channel 3, Signal 2-	34	CH4_CLK+	LVDS Channel 4, Clock +
15	CH3_2+	LVDS Channel 3, Signal 2+	35	GND	Ground
16	GND	Ground	36	CH4_3-	LVDS Channel 4, Signal 3-
17	CH3_CLK-	LVDS Channel 3, Clock -	37	CH4_3+	LVDS Channel 4, Signal 3+
18	CH3_CLK+	LVDS Channel 3, Clock +	38	CH4_4-	LVDS Channel 4, Signal 4-
19	GND	Ground	39	CH4_4+	LVDS Channel 4, Signal4+
20	CH3_3-	LVDS Channel 3, Signal 3-	40	GND	Ground
			41	GND	Ground



LVDS Option = High/Open→NS

NS

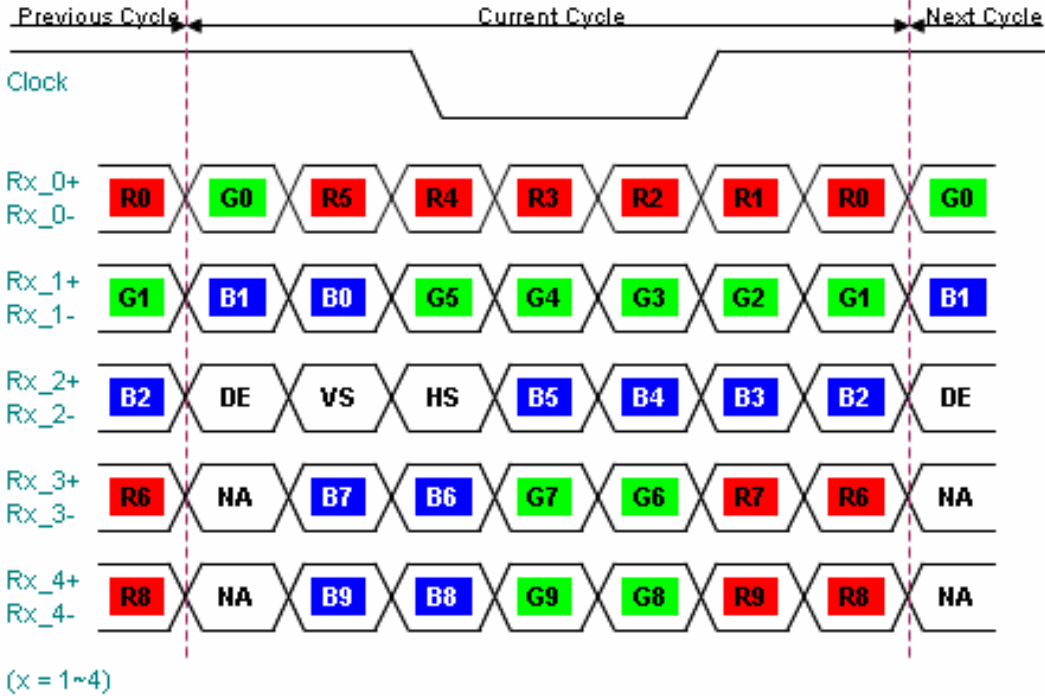

LVDS Option = Low→JEIDA

JEIDA

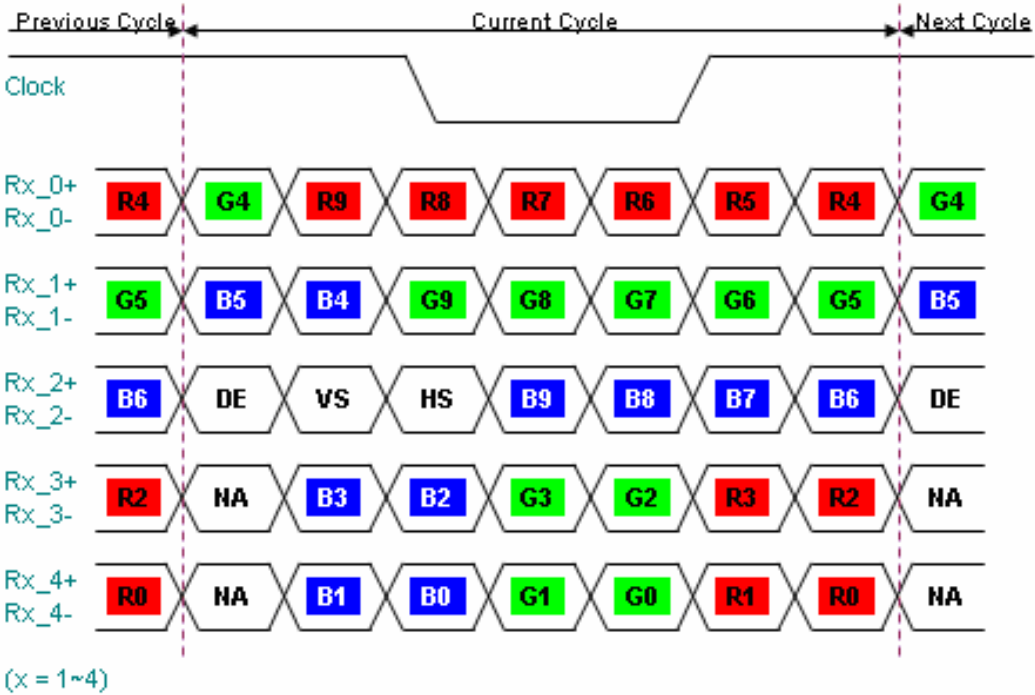



3.3 Signal Timing Specification

This is the signal timing required at the input of the user connector. All of the interface signal timing should be satisfied with the following specifications for its proper operation.

Timing Table (DE only Mode)

Vertical Frequency Range (120Hz)

Signal	Item	Symbol	Min.	Typ.	Max	Unit
Vertical Section	Period	T _v	1090	1130	1160	Th
	Active	T _{disp (v)}	1080			Th
	Blanking	T _{blk (v)}	10	50	80	Th
Horizontal Section	Period	T _h	550	570	580	Tclk
	Active	T _{disp (h)}	480			Tclk
	Blanking	T _{blk (h)}	70	90	100	Tclk
Clock	Frequency	F _{clk=1/Tclk}	71.94	77.29	80.74	MHz
Vertical Frequency	Frequency	F _v	118	120	122	Hz
Horizontal Frequency	Frequency	F _h	130.8	135.6	139.2	KHz

Vertical Frequency Range (100Hz)

Signal	Item	Symbol	Min.	Typ.	Max	Unit
Vertical Section	Period	T _v	1200	1280	1392	Th
	Active	T _{disp (v)}	1080			Th
	Blanking	T _{blk (v)}	120	200	312	Th
Horizontal Section	Period	T _h	550	570	580	Tclk
	Active	T _{disp (h)}	480			Tclk
	Blanking	T _{blk (h)}	70	90	100	Tclk
Clock	Frequency	F _{clk=1/Tclk}	66	72.96	80.74	MHz
Vertical Frequency	Frequency	F _v	96	100	102	Hz
Horizontal Frequency	Frequency	F _h	120	128	139.2	KHz

3.4 Signal Timing Waveforms

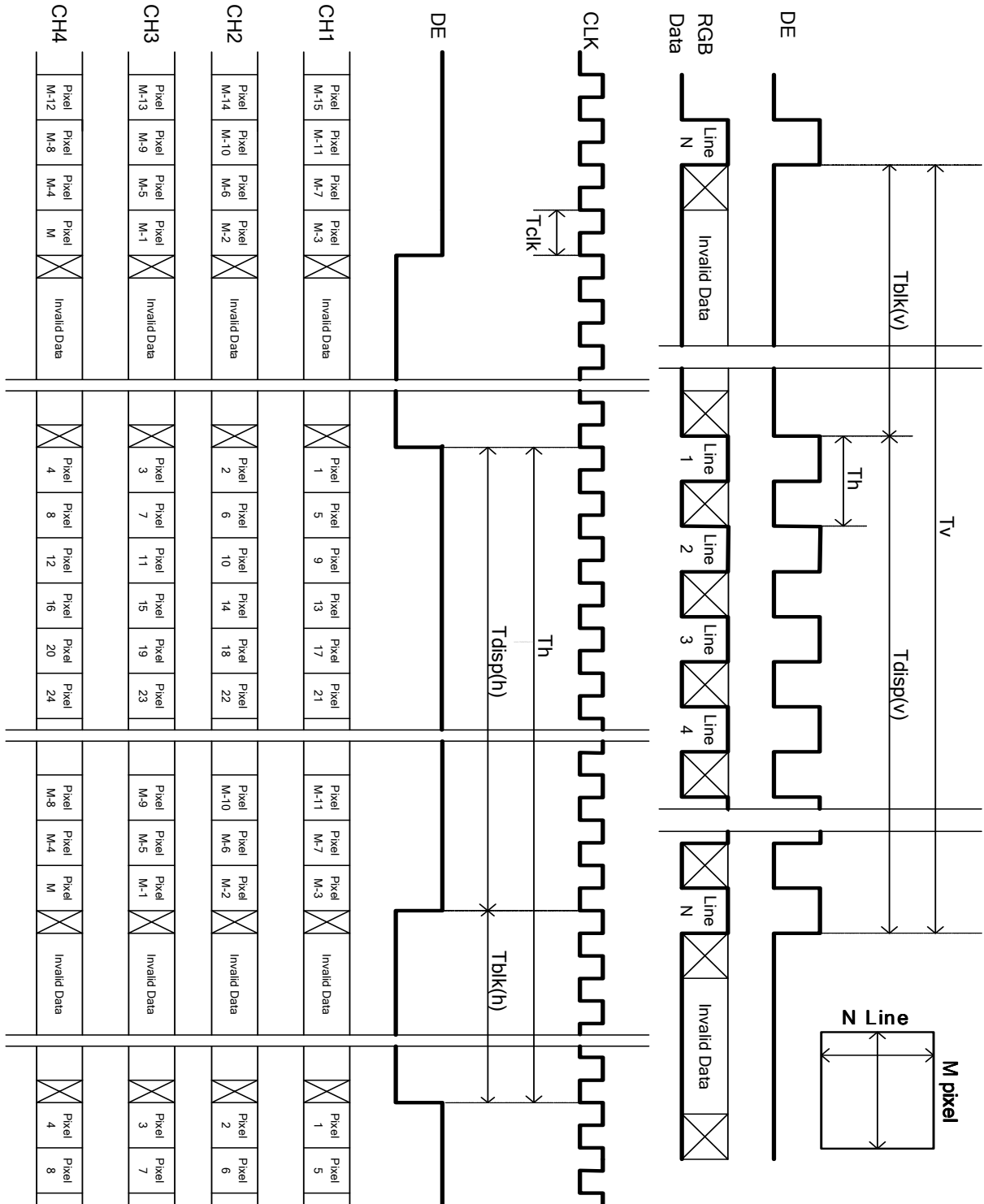



3.5 Color Input Data Reference

The brightness of each primary color (red, green and blue) is based on the 10 bit gray scale data input for the color; the higher the binary input, the brighter the color. The table below provides a reference for color versus data input.

COLOR DATA REFERENCE

Color		Input Color Data																													
		RED										GREEN										BLUE									
		MSB					LSB					MSB					LSB					MSB					LSB				
		R9	R8	R7	R6	R5	R4	R3	R2	R1	R0	G9	G8	G7	G6	G5	G4	G3	G2	G1	G0	B9	B8	B7	B6	B5	B4	B3	B2	B1	B0
Basic Color	Black	0	0	0	0	0	0	0	0	0	0	0	0	0	0	0	0	0	0	0	0	0	0	0	0	0	0	0	0	0	0
	Red(1023)	1	1	1	1	1	1	1	1	1	1	0	0	0	0	0	0	0	0	0	0	0	0	0	0	0	0	0	0	0	0
	Green(1023)	0	0	0	0	0	0	0	0	0	0	1	1	1	1	1	1	1	1	1	1	0	0	0	0	0	0	0	0	0	0
	Blue(1023)	0	0	0	0	0	0	0	0	0	0	0	0	0	0	0	0	0	0	0	0	1	1	1	1	1	1	1	1	1	1
	Cyan	0	0	0	0	0	0	0	0	0	0	1	1	1	1	1	1	1	1	1	1	1	1	1	1	1	1	1	1	1	1
	Magenta	1	1	1	1	1	1	1	1	1	1	0	0	0	0	0	0	0	0	0	0	1	1	1	1	1	1	1	1	1	1
	Yellow	1	1	1	1	1	1	1	1	1	1	1	1	1	1	1	1	1	1	1	1	0	0	0	0	0	0	0	0	0	0
	White	1	1	1	1	1	1	1	1	1	1	1	1	1	1	1	1	1	1	1	1	1	1	1	1	1	1	1	1	1	1
RED	RED(000)	0	0	0	0	0	0	0	0	0	0	0	0	0	0	0	0	0	0	0	0	0	0	0	0	0	0	0	0	0	
	RED(001)	0	0	0	0	0	0	0	0	1	0	0	0	0	0	0	0	0	0	0	0	0	0	0	0	0	0	0	0	0	

	RED(1022)	1	1	1	1	1	1	1	1	0	0	0	0	0	0	0	0	0	0	0	0	0	0	0	0	0	0	0	0	0	
	RED(1023)	1	1	1	1	1	1	1	1	1	0	0	0	0	0	0	0	0	0	0	0	0	0	0	0	0	0	0	0	0	
GREEN	GREEN(000)	0	0	0	0	0	0	0	0	0	0	0	0	0	0	0	0	0	0	0	0	0	0	0	0	0	0	0	0	0	
	GREEN(001)	0	0	0	0	0	0	0	0	0	0	0	0	0	0	0	0	0	0	1	0	0	0	0	0	0	0	0	0	0	

	GREEN(1022)	0	0	0	0	0	0	0	0	0	1	1	1	1	1	1	1	1	0	0	0	0	0	0	0	0	0	0	0	0	
	GREEN(1023)	0	0	0	0	0	0	0	0	0	1	1	1	1	1	1	1	1	1	0	0	0	0	0	0	0	0	0	0		
BLUE	BLUE(000)	0	0	0	0	0	0	0	0	0	0	0	0	0	0	0	0	0	0	0	0	0	0	0	0	0	0	0	0	0	
	BLUE(001)	0	0	0	0	0	0	0	0	0	0	0	0	0	0	0	0	0	0	0	0	0	0	0	0	0	0	0	0	1	

	BLUE(1022)	0	0	0	0	0	0	0	0	0	0	0	0	0	0	0	0	0	0	0	1	1	1	1	1	1	1	1	0	0	
	BLUE(1023)	0	0	0	0	0	0	0	0	0	0	0	0	0	0	0	0	0	0	0	1	1	1	1	1	1	1	1	1	1	

3.6 Power Sequence

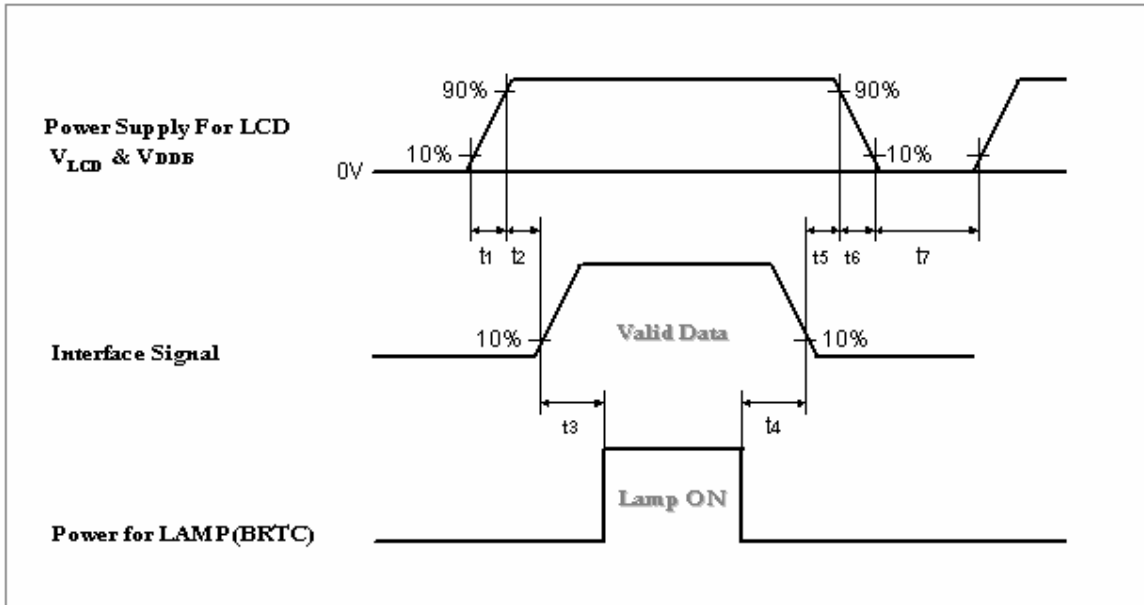

Parameter	Values			Unit
	Min.	Typ.	Max.	
t1	0.4	--	30	ms
t2	0.1	--	--	ms
t3	300	--	--	ms
t4	0 ¹	--	--	ms
t5	0	--	--	ms
t6	--	--	-- ²	ms
t7	500	--	--	ms

Note:

- (1) T4=0 : concern for residual pattern before BLU turn off.
- (2) T6 : voltage of VDD must decay smoothly after power-off. (customer system decide this value)

Apply the lamp voltage within the LCD operating range. When the backlight turns on before the LCD operation or the LCD turns off before the backlight turns off, the display may momentarily become abnormal.

Caution: The above on/off sequence should be applied to avoid abnormal function in the display. In case of handling, make sure to turn off the power when you plug the cable into the input connector or pull the cable out of the connector.

Caution: The above on/off sequence should be applied to avoid abnormal function in the display. In case of handling, make sure to turn off the power when you plug the cable into the input connector or pull the cable out of the connector.

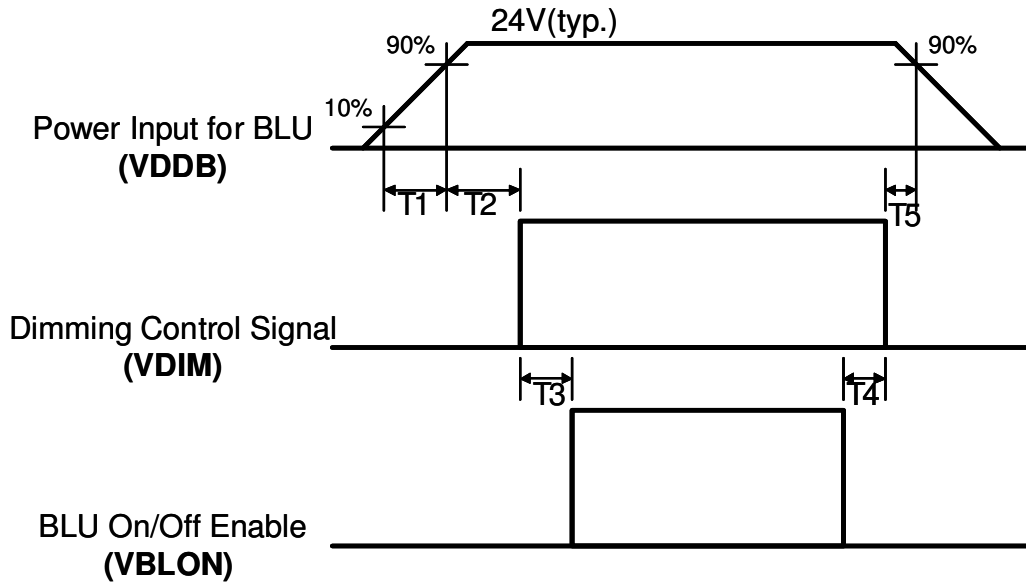

Dip condition for Inverter

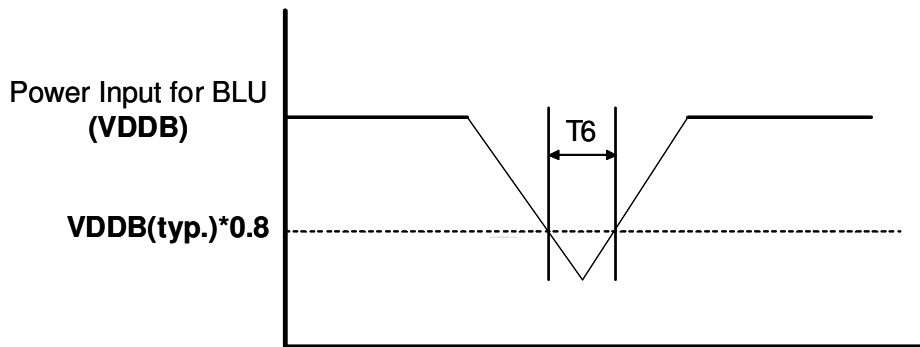

Parameter	Value			Units
	Min	Typ	Max	
T1	20	-	-	ms
T2	500	-	-	ms
T3	250	-	-	ms
T4	0	-	-	ms
T5	1	-	-	ms
T6	-	-	10	ms



3.7 Backlight Power Specification

Item	Symbol		Condition	Spec			Unit	Note
				Min	Typ	Max		
Input Voltage	VDDB		-	21.6	24	26.4	VDC	-
Input Current	IDDB		VDDB=24V	-	10.8	-	ADC	1
Input Power	PDDB		VDDB=24V	-	260	-	W	1
Inrush Current	IRUSH		VDDB=24V	-	-	14	ADC	2
Operating Frequency	FBL		VDDB=24V	53	55	57	KHz	
On/Off control voltage	VBLON	ON	VDDB=24V	2	-	5.5	VDC	-
		OFF		0	-	0.8		-
On/Off control current	IBLON		VDDB=24V	-	-	1.5	mA	-
Internal PWM Dimming Control Voltage	V_IPWM	MAX	VDDB=24V	3.0	-	3.3	VDC	-
		MIN		-	0	-	VDC	-
Internal PWM Dimming Control Current	I_IPWM		VDDB=24V	-	-	2	mADC	-
Internal PWM Dimming Ratio	R_IPWM		VDDB=24V	5	-	100	%	
External PWM Control Voltage	V_EPWM	MAX	VDDB=24V	2	-	3.3	VDC	-
		MIN	VDDB=24V	0	-	0.8		-
External PWM Control Current	I_EPWM		VDDB=24V	-	-	2	mADC	-
External PWM Duty ratio	D_EPWM		VDDB=24V	5	-	100	%	3
External PWM Frequency	F_EPWM		VDDB=24V	140	180	240	Hz	-
Lamp Type				Straight				
Number of Lamps				18			pcs	

Note 1 : Dimming ratio= 100% (MAX) (Ta=25±5°C , Turn on for 45minutes)

Note 2 : Measurement condition Rising time = 20ms (VDDB : 10%~90%);

Note 3 :

For External PWM application, ≥ 5% dimming is function well and no backlight shutdown.

For External PWM application, ≥ 5% dimming is function well and no backlight shutdown.



Connector Pin Assignment

Inverter connector: **CI0114M1HRL-NH (Cvilux)**

Matching Connector: **CI0114S00L0(Cvilux)**

Pin	Symbol	Description
1	VDDB	Operating Voltage Supply, +24V DC regulated
2	VDDB	Operating Voltage Supply, +24V DC regulated
3	VDDB	Operating Voltage Supply, +24V DC regulated
4	VDDB	Operating Voltage Supply, +24V DC regulated
5	VDDB	Operating Voltage Supply, +24V DC regulated
6	BLGND	Ground and Current Return
7	BLGND	Ground and Current Return
8	BLGND	Ground and Current Return
9	BLGND	Ground and Current Return
10	BLGND	Ground and Current Return
11	NC	NC
12	VBLON	BLU On-Off control: BL On : High/Open (3.3V~5.5V); BL off : Low (0~0.8V/GND)
13	VDIM	Internal PWM (0~3.3V for 5~100% Duty, open for 100%) < NC ; at External PWM mode>
14	PDIM	External PWM (5%~100% Duty, open for 100%) < NC ; at Internal PWM mode>

Note 1 : Dimming ratio= 100% (MAX) (Ta=25±5°C , Turn on for 45minutes)

Note 2 : IF External PWM function includes 5% dimming function. Judge condition is shown below:

- 1.) Backlight module must be lighted ON normally.
- 2.) All protection function must operate normally.
- 3.) Uniformity and flicker could NOT be guaranteed!

When External or Internal PWM working Duty ratio is above 20%, all function condition MUST be in SPEC.

4)In Product SPEC Description, Inverter will NOT guarantee optical performance when Dimming ratio under 20%; and NOT guarantee Protection function when Dimming ratio under 5%.

4. Optical Specification

Optical characteristics are determined after the unit has been 'ON' and stable for approximately 60 minutes in a dark environment at 25°C. The values specified are at an approximate distance 500mm from the LCD surface at a viewing angle of φ and θ equal to 0°.

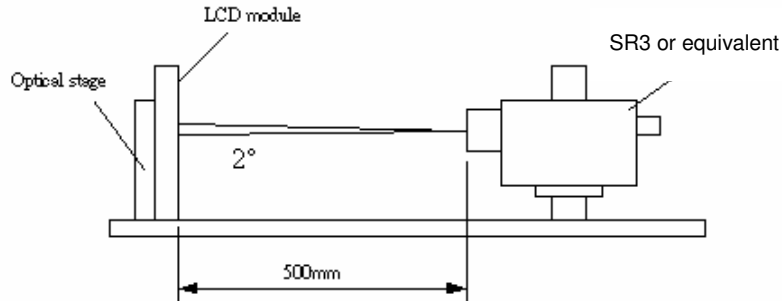

Parameter	Symbol	Values			Unit	Notes
		Min.	Typ.	Max		
Contrast Ratio	CR	4000	5000	--		1
Surface Luminance (White)	L_{WH}	360	450	--	cd/m ²	2
Luminance Variation	$\delta_{WHITE(9P)}$	--	--	1.3		3
Response Time (Average)	T _γ	--	6.5	--	ms	4 (Gray to Gray)
Color Coordinates						
Red	R _x	Typ.-0.03	0.640	Typ.+0.03		
	R _y		0.330			
Green	G _x		0.290			
	G _y		0.600			
Blue	B _x		0.150			
	B _y		0.060			
White	W _x		0.280			
	W _y		0.290			
Viewing Angle (Contrast Ratio>10)						
x axis, right($\varphi=0^\circ$)	θ_r	--	89	--	degree	5
x axis, left($\varphi=180^\circ$)	θ_l	--	89	--	degree	5
y axis, up($\varphi=90^\circ$)	θ_u	--	89	--	degree	5
y axis, down ($\varphi=270^\circ$)	θ_d	--	89	--	degree	5



Note:

1. Contrast Ratio (CR) is defined mathematically as:

$$\text{Contrast Ratio (CR)} = \frac{\text{Brightness of the "white" state}}{\text{Brightness of the "black" state}}$$

2. Surface Luminance is luminance value at point 5 with 100% dimming across the LCD surface 50cm from the surface with all pixels displaying white. For more information see Fig. 4-2. When lamp current $I_L=7.6\text{mA}$, $L_{WH}=L_{on5}$, where L_{on5} is the luminance with all pixels displaying white at center 5 location.

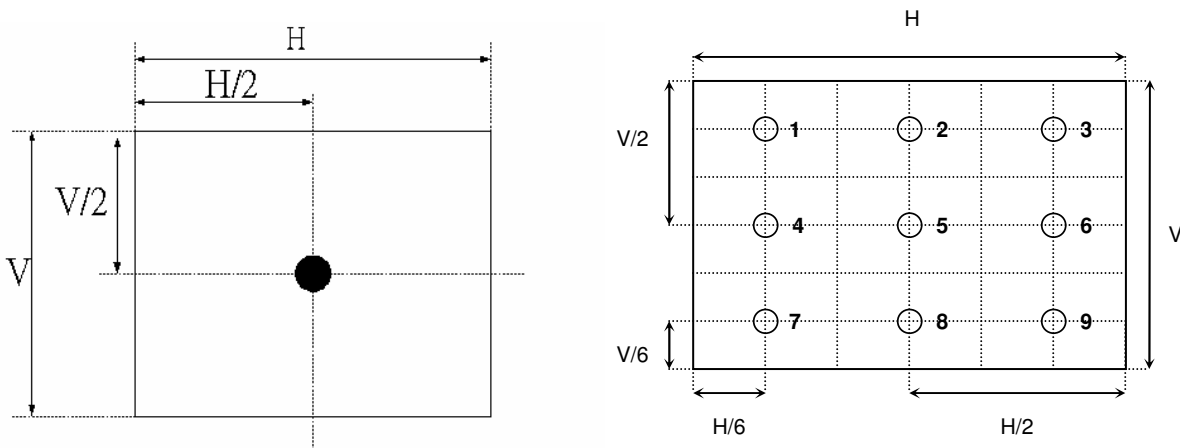

Fig.4-2 Optical measurement point

3. The variation in surface luminance, $\delta_{\text{WHITE}(9P)}$ is defined under brightness of $I_L=9\text{mA}$ as:

$$\delta_{\text{WHITE}(9P)} = \frac{\text{Maximum}(L_{on1}, L_{on2}, \dots, L_{on9})}{\text{Minimum}(L_{on1}, L_{on2}, \dots, L_{on9})}$$

4. Response time T_γ is the average time required for display transition by switching the input signal for five luminance ratio (0%, 25%, 50%, 75%, 100% brightness matrix) and is based on $f_v=60\text{Hz}$ to optimize.

	0%	25%	50%	75%	100%
0%		t:0%-25%	t:0%-50%	t:0%-75%	t:0%-100%
25%	t:25%-0%		t:25%-50%	t:25%-75%	t:25%-100%
50%	t:50%-0%	t:50%-25%		t:50%-75%	t:50%-100%
75%	t:75%-0%	t:75%-25%	t:75%-50%		t:75%-100%
100%	t:100%-0%	t:100%-25%	t:100%-50%	t:100%-75%	

5. Viewing angle is the angle at which the contrast ratio is greater than 10. The angles are determined for the horizontal (or x-axis) and the vertical (or y-axis) with respect to the z-axis which is normal to the LCD surface. For more information see Fig. 4-4.

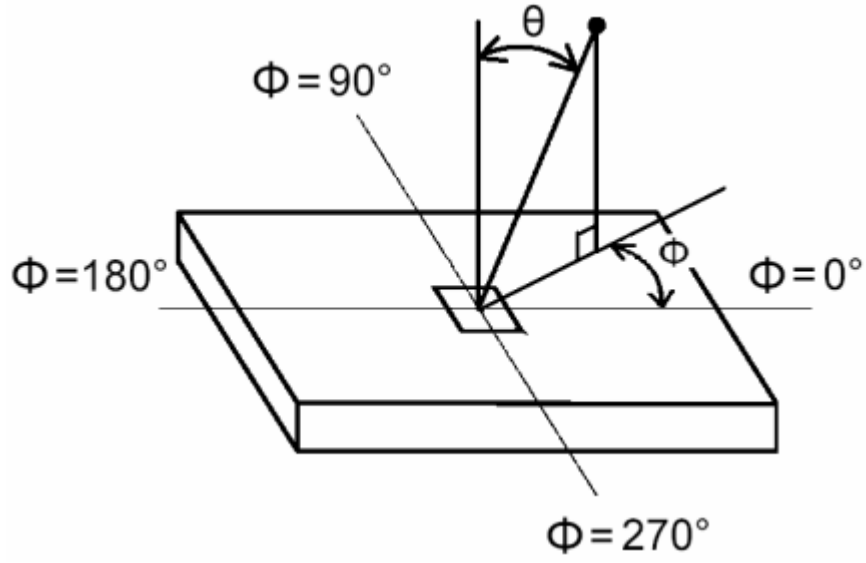

Fig.4-4 Viewing angle definition



5. Mechanical Characteristics

The contents provide general mechanical characteristics for the model T546HW01. In addition the figures in the next page are detailed mechanical drawing of the LCD.

Outline Dimension	Horizontal (typ.)	1286 mm
	Vertical (typ.)	745 mm
	Depth (typ.)	60 mm
Bezel Area	Horizontal (typ.)	1217.6 mm
	Vertical (typ.)	688.4 mm
Active Display Area	Horizontal	1209.6 mm
	Vertical	680.4 mm
Weight	20500g (typ)	

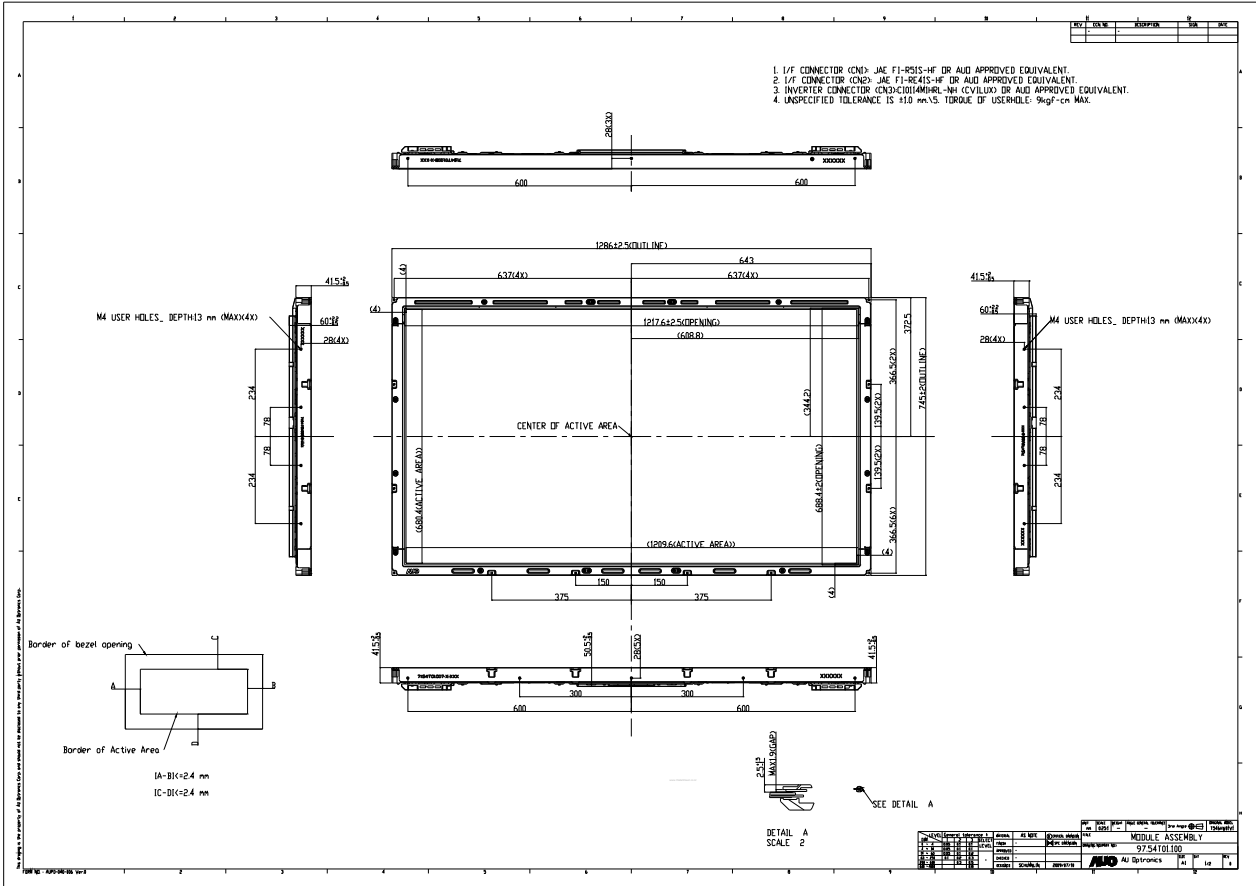



6. Reliability test item

	Test Item	Q'ty	Condition
1	High temperature storage test	3	60°C , 300hrs
2	Low temperature storage test	3	-20°C , 300hrs
3	High temperature operation test	3	50°C , 300hrs
4	Low temperature operation test	3	-5°C , 300hrs
5	Vibration test (non-operation)	3	(10~300Hz/1.5G/11min SR, XYZ 30,im/axis) Vibration level : 1.5G RMS, Bandwidth: 10-300Hz Duration: X, Y, Z 30min
6	Shock test (non-operation)	3	Shock level: 50G Waveform: half sine wave, 11ms Direction: ±X, ±Y, ±Z, One time each direction
7	Vibration test (With carton)	3	Random wave (1.5G RMS, 10-200Hz) 30mins/ Per each X,Y,Z axes
8	Drop test (With carton)	3	Height: 25.4cm 6 surfaces (ASTMD4169-I)



7. International Standard

7-1. Safety

- (1) UL6500, UL 60065 Underwriters Laboratories, Inc. (AUO file number: E204356)
Standard for Safety of Information Technology Equipment Including electrical Business Equipment.
- (2) CAN/CSA C22.2 No. 950-95 Third Edition, Canadian Standards Association, Jan. 28, 1995
Standard for Safety of Information Technology Equipment Including Electrical Business Equipment.
- (3) EN60950: 1992+A2: 1993+A2: 1993+C3: 1995+A4: 1997+A11: 1997
IEC 950: 1991+A1: 1992+A2: 1993+C3: 1995+A4:1996
IEC 60065: version 7th
European Committee for Electro technical Standardization (CENELEC)
EUROPEAN STANDARD for Safety of Information Technology Equipment Including Electrical Business Equipment.

7-2. EMC

- (1) ANSI C63.4 "Methods of Measurement of Radio-Noise Emissions from Low-Voltage Electrical and Electrical Equipment in the Range of 9kHz to 40GHz. "American National standards Institute(ANSI), 1992
- (2) C.I.S.P.R "Limits and Methods of Measurement of Radio Interface Characteristics of Information Technology Equipment." International Special committee on Radio Interference.
- (3) EN 55022 "Limits and Methods of Measurement of Radio Interface Characteristics of Information Technology Equipment." European Committee for Electrotechnical Standardization. (CENELEC), 1998

7-3. Green Mark Description

- (1) For Pb Free products, AUO will add  for identification.
- (2) For RoHS compatible products, AUO will add RoHS for identification.

Note. The Green Mark will be present only when the green documents have been ready by AUO Internal Green Team. (The definition of green design follows the AUO green design checklist.)



8. Packing

Packing Instruction

Carton dimension= 1355mm*560mm*830mm

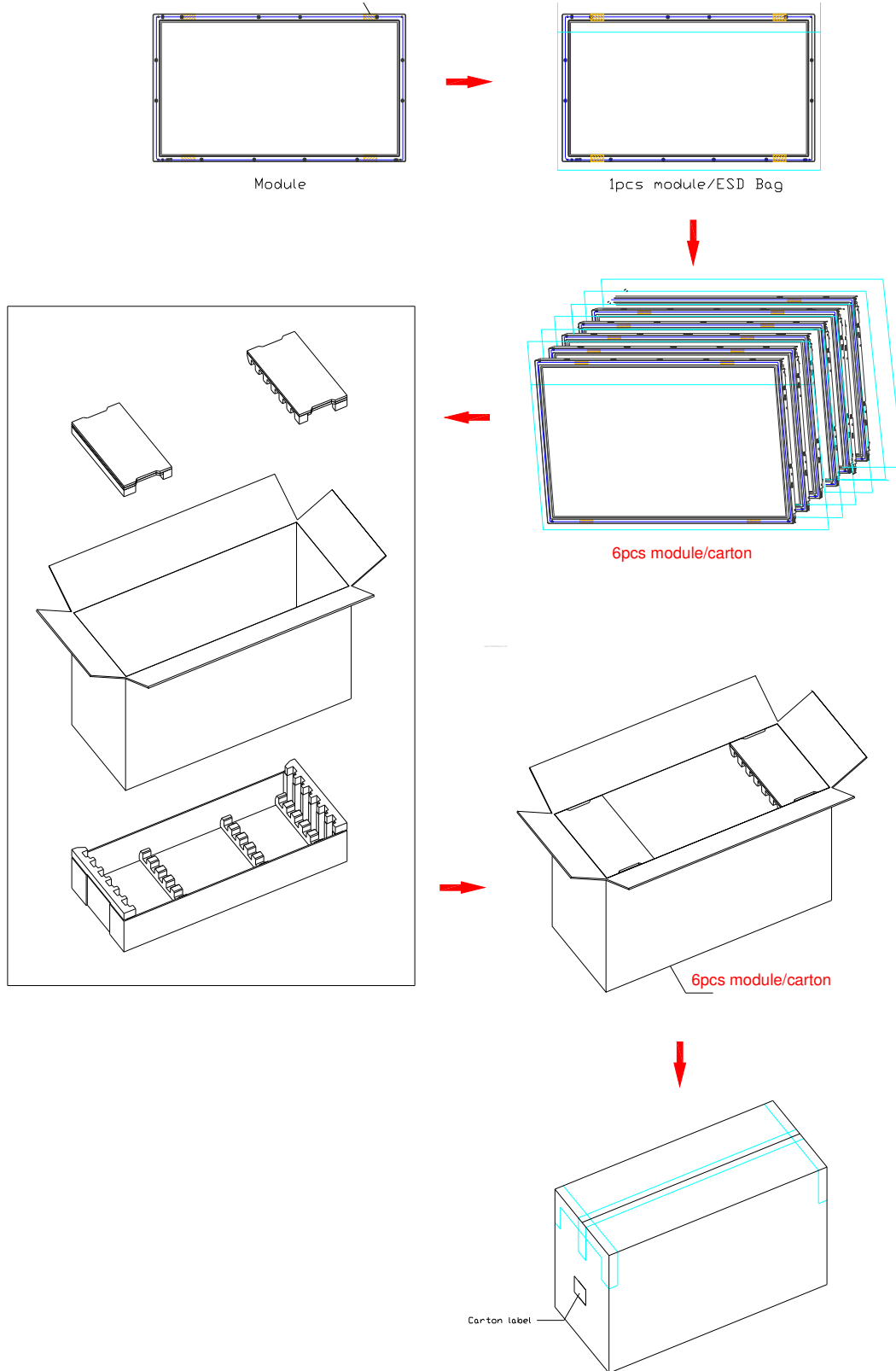



Pallet information

By air cargo: (2 x 1) x 1 layers, one pallet put 2 boxes, total 12 pcs module.

Dimension: 1390mm*1150mm*962mm

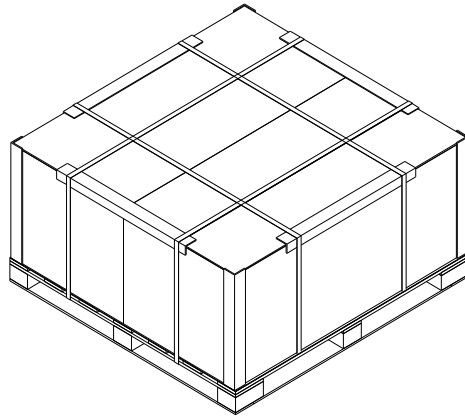

By sea: (2 x 1) x 2 layers, one pallet put 2 boxes, stack 2 layers, total 24 pcs module.

Dimension: 1390 x 1150 x 1924mm

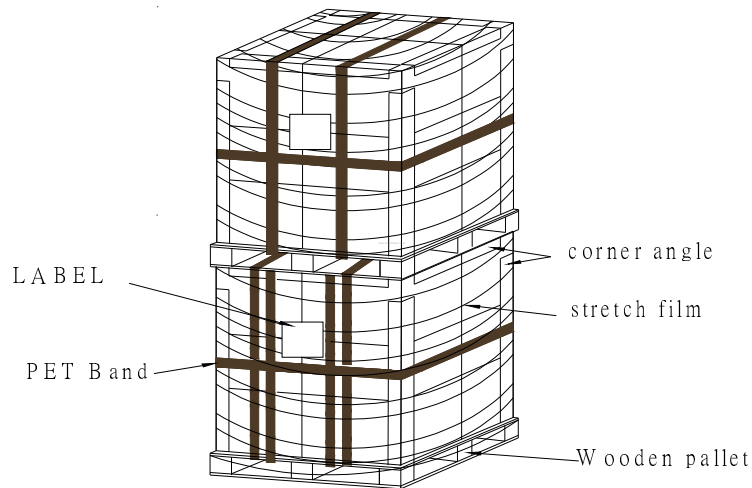

Pallet dimension: 1390mm*1150mm*132mm (T55)

	Item	Specification			Packing Remark
		Qty.	Dimension	Weight (kg)	
1	Packing BOX	6pcs/box	1355(L)mm*560(W)mm*830(H)mm	133	
2	Pallet	1	1390(L)mm*1150(W)mm*132(H)mm	20	
3	Boxes per Pallet	2 boxes/Pallet			
4	Panels per Pallet	12pcs/pallet			
	Pallet after packing	1	1390(L)mm*1150(W)mm*962(H)mm	286	



Panel Label

	Manufactured XX/XX		
XXXXXXXXXXXX-XXXXXX	Model No T546HW01 V1		
	AU Optronics XXXXG	E204356	
	Made in China (S11)		
			
AUXXXXXXXXXXXXXXXXXXXX			

Carton Label

		
AU Optronics		
MODEL NO: T546HW01 V1	QTY: 6	
PART NO: 97.54T01.XXX		
CUSTOMER NO: —		
CARTON NO:		
Made in XXXXXX	*XXXXXXXX-XXXXXXXXXX*	



9. Precautions

Please pay attention to the followings when you use this TFT LCD module.

8-1 MOUNTING PRECAUTIONS

- (1) You must mount a module using holes arranged on back side of panel
- (2) You should consider the mounting structure so that uneven force (ex. Twisted stress) is not applied to module. And the case on which a module is mounted should have sufficient strength so that external force is not transmitted directly to the module.
- (3) Please attach the surface transparent protective plate to the surface in order to protect the polarizer. Transparent protective plate should have sufficient strength in order to resist external force.
- (4) You should adopt radiation structure to satisfy the temperature specification.
- (5) Acetic acid type and chlorine type materials for the cover case are not desirable because the former generates corrosive gas of attacking the polarizer at high temperature and the latter causes circuit break by electro-chemical reaction.
- (6) Do not touch, push or rub the exposed polarizers with glass, tweezers or anything harder than HB pencil lead. And please do not rub with dust clothes with chemical treatment. Do not touch the surface of polarizer for bare hand or greasy cloth. (Some cosmetics are detrimental to the polarizer.)
- (7) When the surface becomes dusty, please wipe gently with absorbent cotton or other soft materials like chamois soaks with petroleum benzene. Normal-hexane is recommended for cleaning the adhesives used to attach front/ rear polarizers. Do not use acetone, toluene and alcohol because they cause chemical damage to the polarizer.
- (8) Wipe off saliva or water drops as soon as possible. Their long time contact with polarizer causes deformations and color fading.
- (9) Do not open the case because inside circuits do not have sufficient strength.

8-2 OPERATING PRECAUTIONS

- (1) The spike noise causes the mis-operation of circuits. It should be lower than following voltage:
 $V = \pm 200\text{mV}$ (Over and under shoot voltage)
- (2) Response time depends on the temperature. (In lower temperature, it becomes longer.)
- (3) Brightness depends on the temperature. (In lower temperature, it becomes lower.) And in lower temperature, response time (required time that brightness is stable after turned on) becomes longer.
- (4) Be careful for condensation at sudden temperature change. Condensation makes damage to polarizer or electrical contacted parts. And after fading condensation, smear or spot will occur.
- (5) When fixed patterns are displayed for a long time, remnant image is likely to occur.
- (6) Module has high frequency circuits. Sufficient suppression to the electromagnetic interference shall be done by system manufacturers. Grounding and shielding methods may be important to minimize the interface.
- (7) The device listed in the product specification sheets was designed and manufactured for TV application.



8-3 ELECTROSTATIC DISCHARGE CONTROL

Since a module is composed of electronic circuits, it is not strong to electrostatic discharge. Make certain that treatment persons are connected to ground through wrist band etc. And don't touch interface pin directly.

8-4 PRECAUTIONS FOR STRONG LIGHT EXPOSURE

Strong light exposure causes degradation of polarizer and color filter.

8-5 STORAGE

When storing modules as spares for a long time, the following precautions are necessary.

- (1) Store them in a dark place. Do not expose the module to sunlight or fluorescent light. Keep the temperature between 5°C and 35°C at normal humidity.
- (2) The polarizer surface should not come in contact with any other object. It is recommended that they be stored in the container in which they were shipped.

8-6 HANDLING PRECAUTIONS FOR PROTECTION FILM

- (1) The protection film is attached to the bezel with a small masking tape. When the protection film is peeled off, static electricity is generated between the film and polarizer. This should be peeled off slowly and carefully by people who are electrically grounded and with well ion-blown equipment or in such a condition, etc.
- (2) When the module with protection film attached is stored for a long time, sometimes there remains a very small amount of glue still on the Bezel after the protection film is peeled off.
- (3) You can remove the glue easily. When the glue remains on the Bezel or its vestige is recognized, please wipe them off with absorbent cotton waste or other soft material like chamois soaked with normal-hexane