

GENERAL DESCRIPTION

The PT1202 is a high efficiency monolithic current mode synchronous buck regulator with a constant operation frequency. A main switch and a synchronous switch are integrated in PT1202, the device has high efficiency and no external Schottky diode needed. Supply current is 300uA during operation and drops to $\leq 1\mu\text{A}$ in shutdown. The 2.5V to 5.5V input voltage range makes the PT1202 ideally suited for single Li-Ion battery-powered applications. 100% duty cycle provides low dropout operation, extending battery life in portable systems. Automatic skip cycle operation mode at light loads provides very low output ripple for noise sensitive applications. Internal 1.9MHz switching frequency allowing the use of small surface mount inductors and capacitors. Ultra low output voltages are easily available with the 0.6V feedback reference voltage.

The PT1202 is offered in a low profile SOT package and is available in an adjustable version and fixed output voltages versions from 0.6v to 1.8v.

FEATURES

- High Efficiency: Up to 96%
- Low Quiescent Current: 300 μA
- 600mA Output Current
- 2.5V to 5.5V Input Voltage Range
- 1.9MHz Constant Frequency Operation
- Internal integrated main switch and rectifier, no Schottky Diode Required
- Low Dropout Operation: 100% Duty Cycle
- 0.6V Reference Allows Low Output Voltages
- Shutdown Mode Draws $\leq 1\mu\text{A}$ Supply Current
- Current Mode Operation for Excellent Line and Load Transient Response
- Over-temperature Protected
- Low Profile SOT Package
- RoHS compliant

APPLICATIONS

- Cellular and Smart Phones
- Personal Information Appliances
- Microprocessors and DSP Core Supplies
- Wireless and DSL Modems
- Digital Still Cameras
- MP3 Players and PDAs
- Portable Instruments

ORDERING INFORMATION

PACKAGE	TEMPERATURE RANGE	ORDERING PART NUMBER	TRANSPORT MEDIA	MARKING
SOT23-5	-40 °C to 85 °C	PT1202E23E-ADJ	Tape and Reel 3000 units	1202z

TYPICAL APPLICATION CIRCUIT

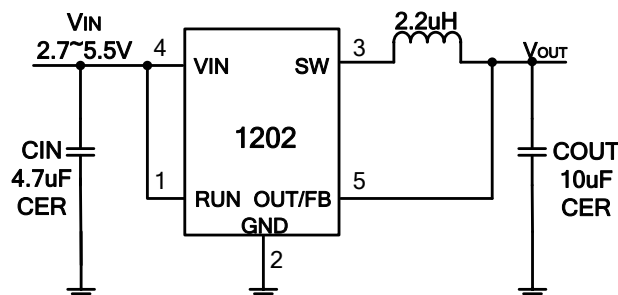

PIN ASSIGNMENT

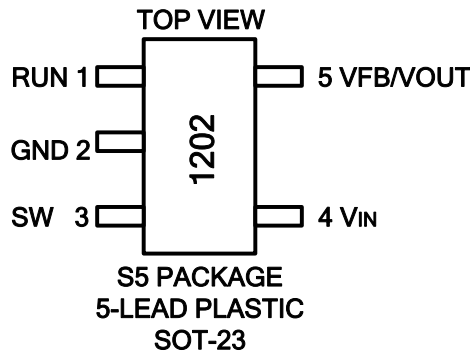

PIN DESCRIPTIONS

PIN NAMES	PIN No.	DESCRIPTION
RUN	1	Chip Enable, Active with 'H'
GND	2	Chip Ground
SW	3	Output of Internal Switches
VIN	4	Power Supply
V _{FB} /V _{OUT}	5	Regulated Feedback/Output Voltage

ABSOLUTE MAXIMUM RATING (Note1)

SYMBOL	ITEMS	VALUE	UNIT
V _{IN}	Input Supply Voltage	- 0.3 to 6	V
V _{RUN}	RUN Pin Voltage	- 0.3 to V _{IN}	V
V _{FB}	FB Pin Voltage	- 0.3 to V _{IN}	V
V _{SW}	SW Pin Voltage	- 0.3 to (V _{IN} + 0.3)	V
I _{SW}	SW Pin Source/Sink Current (DC)	± 1	A
I _{SW}	SW Pin Source/Sink Current (peak)	± 1.5	A
T _J	Junction Temperature	125	°C
T _{OPER}	Operating Temperature Range	- 40 to 85	°C
T _{STG}	Storage Temperature Range	- 65 to 150	°C
T _{SOLDER}	Lead Temperature (Soldering, 10 sec)	300	°C
θ _{JA}	Thermal Resister	220	°C/W

Note1: Absolute Maximum Ratings are those values beyond which the life of the device maybe impaired.

ELECTRICAL CHARACTERISTICS

TA = 25 °C. VRUN=VIN = 3.6V unless otherwise specified.

SYMBOL	PARAMETER	CONDITIONS	MIN	TYP	MAX	UNITS
VFB	Regulated Feedback Voltage	TA=25 °C	0.588	0.600	0.612	V
ΔV_{FB}	Line Regulation	VIN = 2.5V to 5.5V		0.04	0.5	%/V
IFB	VFB Input Bias Current			0	±30	nA
IPK	Peak Inductor Current	VIN = 3V, VFB = 0.5V, Duty Cycle < 35%		1		A
VLOADREG	Load Regulation			0.5		%
VIN	Input Voltage Range		2.5		5.5	V
IS	Input DC Bias Current Active Mode Shutdown	VFB = 0.5V or VOUT = 90%, ILOAD = 0A VRUN = 0V, VIN = 4.2V		300 0.1	400 1	μA
FOSC	Oscillator Frequency	VFB = 0.6V or VOUT = 100%	1.5	1.9	2.3	MHz
RPFET	RDS(ON) of P-Channel FET	ISW = 100mA		0.4	0.5	Ω
RNFET	RDS(ON) of N-Channel FET	ISW = -100mA		0.35	0.45	Ω
ILSW	SW Leakage	VRUN = 0V, VSW = 0V or 5V, VIN = 5V		±0.01	±1	μA
VRUN	RUN Threshold Voltage	-40 °C ≤ TA ≤ 85 °C	0.3	1.0	1.50	V

Note: The Min and Max value is guaranteed by final test or lab statistic.

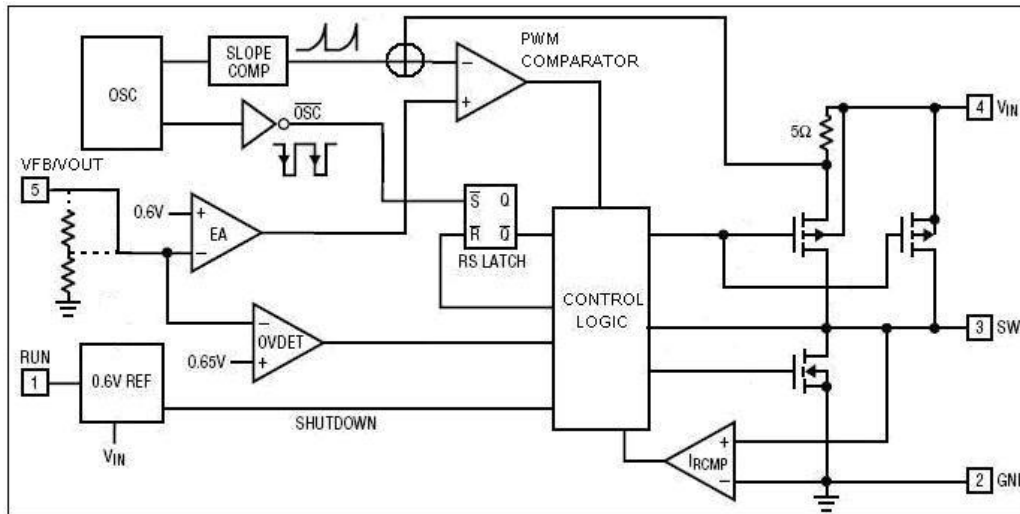
SIMPLIFIED BLOCK DIAGRAM

OPERATION DESCRIPTION

The PT1202 is a high efficiency monolithic current mode synchronous buck regulator with a constant operation frequency. Its internal integrated MOSFETs achieve high efficiency. Ultra low output voltages are easily available with the 0.6V feedback reference voltage. Internal fixed 1.9MHz switching frequency allowing the use of small surface mount inductors and capacitors. The 2.5V to 5.5V input voltage range and 600mA output current make the PT1202 ideally suited for single Li-Ion battery-powered applications.

Current Mode PWM Control Loop

Slope compensated current mode PWM control and cycle-by-cycle current limit provides stable operation and excellent line and load regulation. During normal operation, the internal top power MOSFET is turned on each cycle when the rising edge of the oscillator sets the RS latch, and turned off when rising edge of the PWM comparator resets the RS latch. While the top MOSFET is off, the bottom MOSFET is turned on until either the inductor current starts to reverse or the beginning of the next clock cycle. The OVDET comparator controls output transients overshoots is smaller than 8% by turning the main MOSFET off until the fault is removed.

Skip-Cycles Mode Operation

At light loads, the PT1202 enters skip-cycle mode automatically. In this mode, the inductor current may reach zero or reverse on each cycle. The PWM control loop will automatically skip cycles to maintain output regulation. The bottom MOSFET is turned off by the

current reversal comparator, IR-CMPARATOR, and the switch voltage will ring. This is discontinuous mode operation, and is normal behavior for the switching regulator.

Current Fold-Back Operation

The frequency of the oscillator is reduced to about 210 KHz when the output voltage is smaller than 50% of normal value; which ensures the inductor current has more time to decay, thereby preventing runaway. The oscillator's frequency will progressively increase to 1.9MHz when the output voltage rises above 50%.

Low-Dropout Operation

When the input voltage decreases to the value of output voltage, the control loop remains the main MOSFET on until it reaches 100% duty cycle. The output voltage then is the input voltage minus the voltage drop across the main switch and the inductor. Caution must be exercised to ensure the heat dissipated not to exceed the maximum junction temperature of the IC because the RDSON of the main MOSFET increases and the efficiency of the converter decrease.

Maximum Load Current

The PT1202 operates with input voltage as low as 2.5V. However, the maximum load current decreases when the input voltage decreases because of the large IR drop of the main switch and the synchronous switch. And the slope compensation reduces the peak inductor current.

TYPICAL PERFORMANCE CHARACTERISTICS

(From Figure 1, TA=25°C Unless Otherwise Specified)

Efficiency vs. Input Voltage

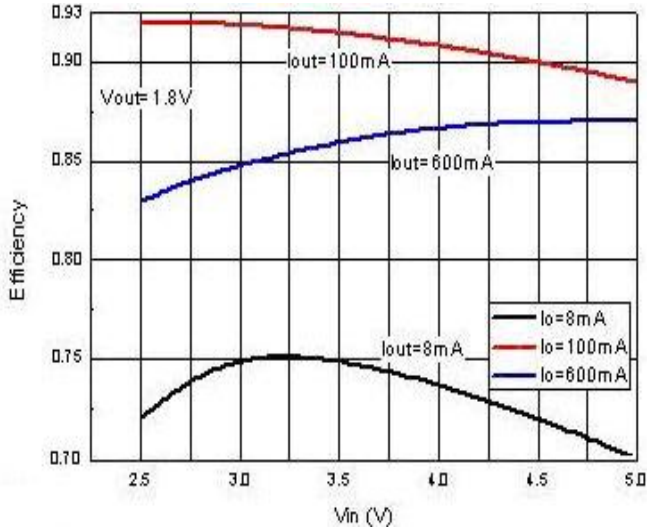

Efficiency vs. Output Current

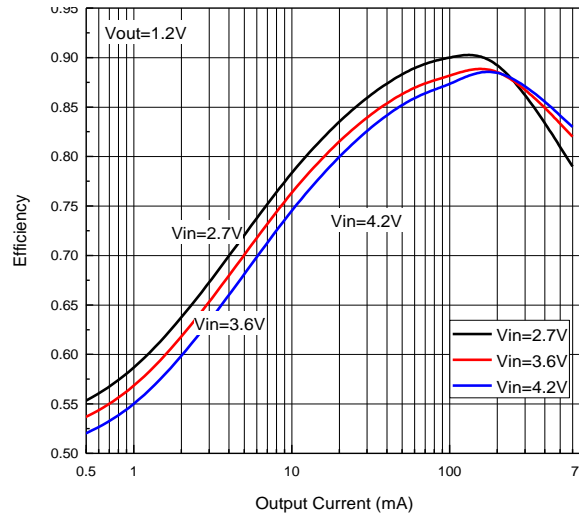

Efficiency vs. Output Current

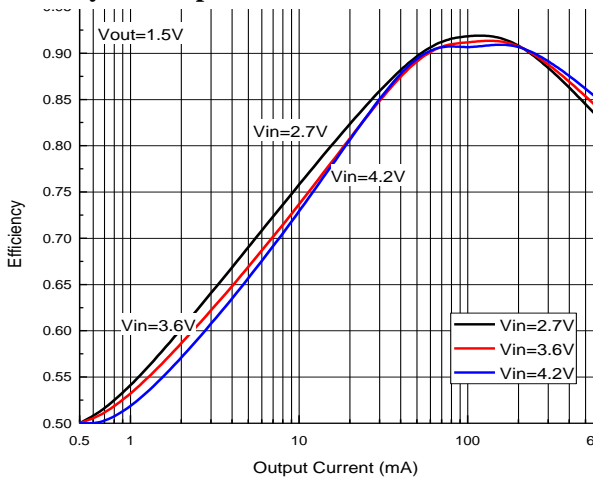

Efficiency vs. Output Current

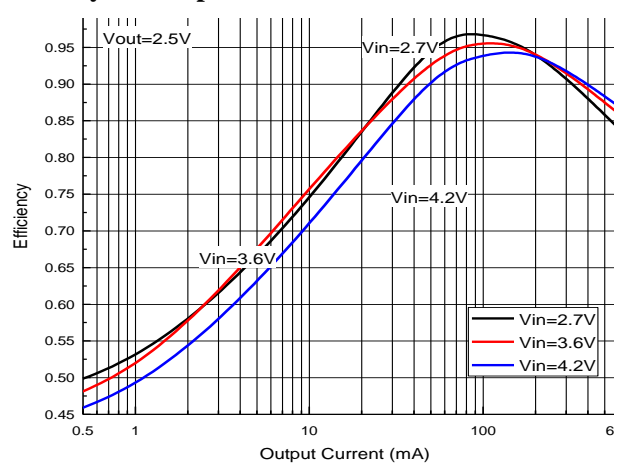

Reference Voltage (V) vs. Temperature (°C)

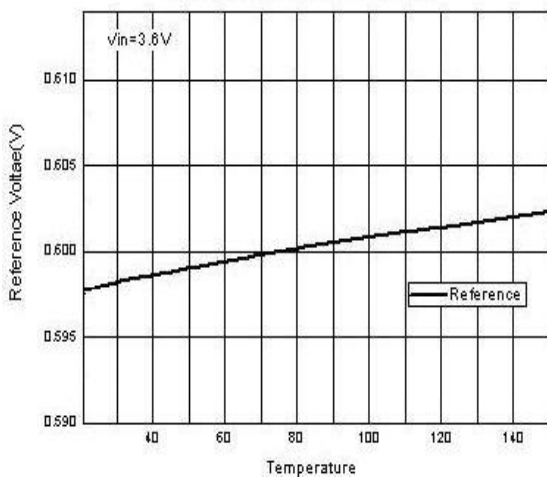

Oscillator Frequency vs. VIN

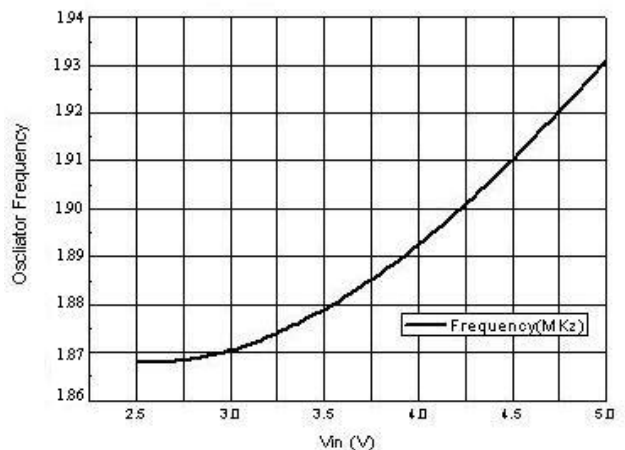

Oscillator Frequency vs. Temperature (°C)

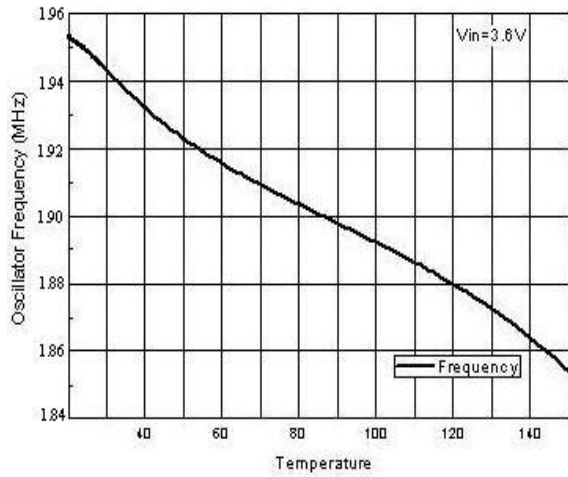

Supply Current vs. Temperature (°C)

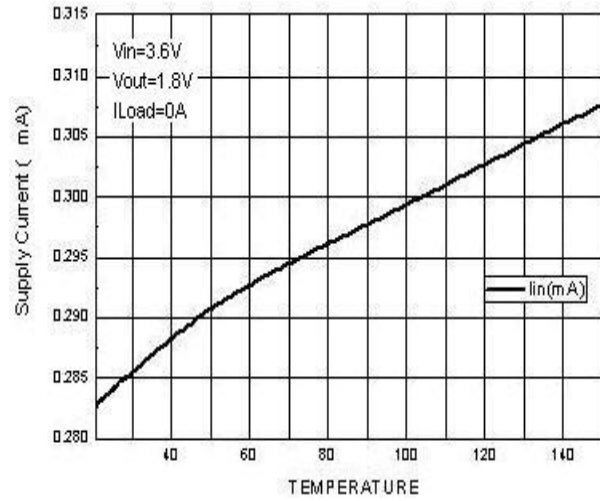

Supply Current vs. Supply Voltage

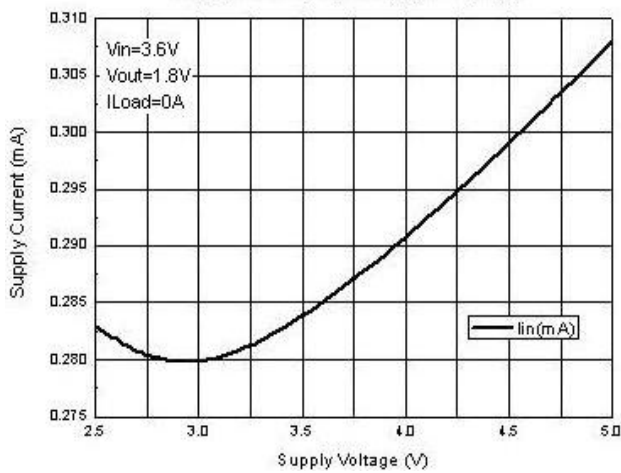

Start-up from Shutdown

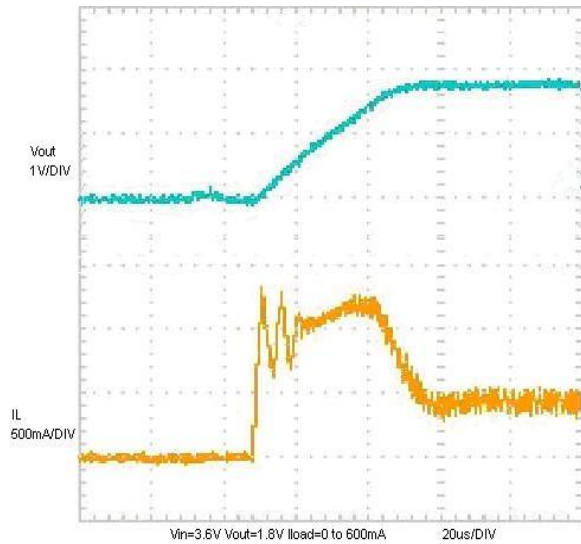

Load Step

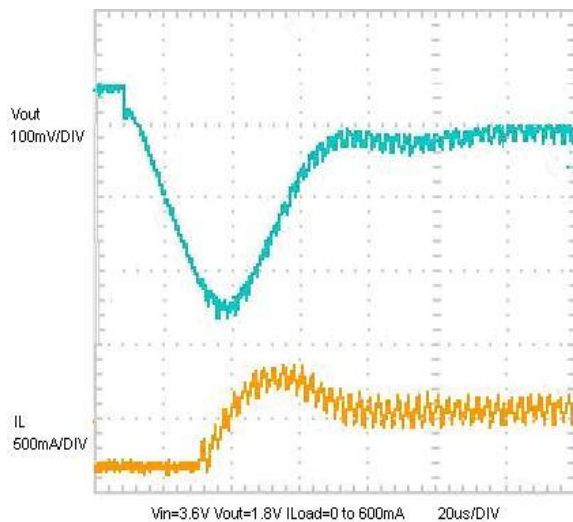

Load Step

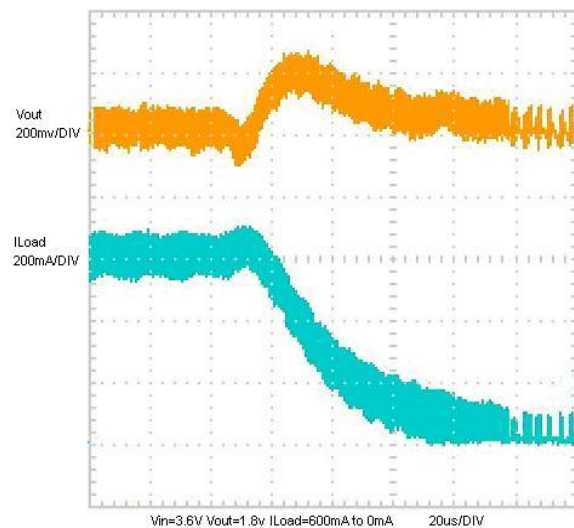

APPLICATIONS INFORMATION

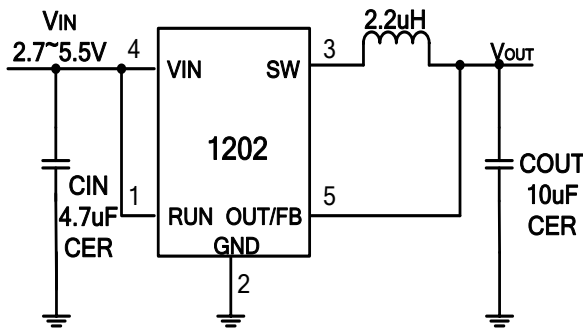

Figure 1

Setting the Output Voltage

Figure 1 shows the application of fixed output voltage version of PT1202. There are 0.6V to 5V versions are available. In these versions, the output voltage is set by an internal resistor divider.

Figure 2 shows the application of adjust version of PT1202. In this version, the output voltage is set by an external resistor divider according to the following formula:

$$V_{OUT} = 0.6V \times \left(1 + \frac{R2}{R1}\right)$$

Inductor Selection

For most applications, the PT1202 operates well with inductors of 1uH to 4.7uH. Low inductance values are physically smaller but require fast switching, which results in efficiency loss. The inductor value can be calculated from following equation:

$$L = \frac{V_{OUT} \times (V_{IN} - V_{OUT})}{V_{IN} \times \Delta I_L \times f_{OSC}}$$

Table 1 list some typical surface mount inductors that adapt to PT1202 applications.

Part #	L (uH)	Max DCR (mΩ)	Rated D.C. Current (A)	Size WxLxH (mm)
Sumida CR43	1.4	56.2	2.52	4.5x4.0x3.5
	2.2	71.2	1.75	
	3.3	86.2	1.44	
	4.7	108.7	1.15	
Sumida CDRH4D18	1.5	75	1.32	4.7x4.7x2.0
	2.2		1.04	
	3.3		0.84	
	4.7			
Toko D312C	1.5	120	1.29	3.6x3.6x1.2
	2.2	140	1.14	
	3.3	180	0.98	
	4.7	240	0.79	

Table 1. Typical Surface Mount Inductors

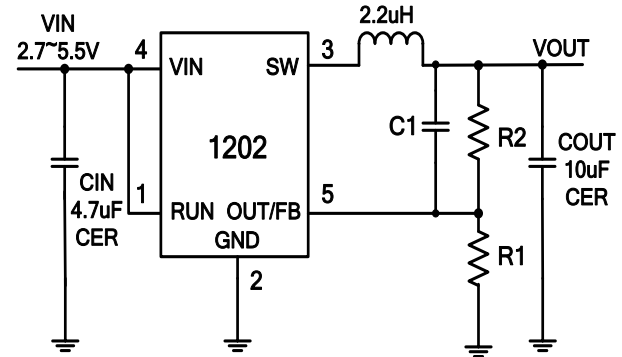

Figure 2

Input and Output Capacitor Selection

The input capacitor reduces the surge current drawn from the input and switching noise from the device. To prevent large voltage transients, a low ESR input capacitor sized for the maximum RMS current must be used. The maximum RMS capacitor current is given by:

$$I_{RMS} \approx I_{OMAX} \times \frac{[V_{OUT} (V_{IN} - V_{OUT})]^{1/2}}{V_{IN}}$$

Ceramic capacitor with X5R or C7R dielectrics are highly recommended because of their low ESR and small temperature coefficients. A 4.7uF ceramic capacitor for most applications is sufficient.

The output capacitor is required to obtain small output voltage ripple and ensure regulation loop stability. Typically, once the ESR requirement for COUT has been met, the RMS current generally far exceeds the ripple current requirement. The output ripple ΔV_{OUT} is determined by:

$$\Delta V_{OUT} \approx \Delta I_L \times \left(ESR + \frac{1}{8fC_{OUT}}\right)$$

Where f is the operating frequency, COUT is the output capacitor and ΔI_L is the ripple current of inductor current.

Ceramic capacitors with X5R or C7R dielectrics are recommended due to their low ESR and high current rating. A 10uF ceramic capacitor for most applications is recommended for low output voltage ripple and good loop stability.

Adapter/USB Applications

For USB or adapter applications, there is $\pm 10\%$ voltage variation in the power supply; this device could be harmed if VIN is higher than 5.5V. To protect the device, a zener diode with 5.6V break down voltage (D1 in Fig. 3) is suggested to be added between VIN and GND in

this kind of applications.

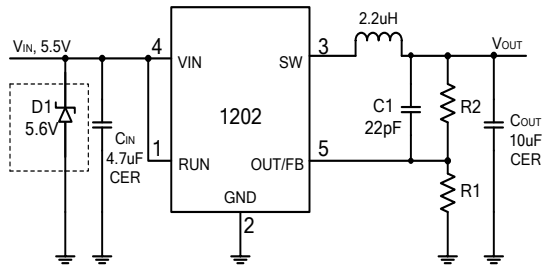

Layout Guideline

1. The power traces, including the VIN trace, the GND trace, and the SW trace should be kept short, direct and wide.
2. The VFB pin should be connected directly to the

feedback resistor, and kept away from the switching node, SW. The resistive divider R1/R2 must be connected between the (+) plane of COUT and ground.

3. Place the (+) plane of CIN to the VIN pin as close as possible.
4. Keep the (-) plates of CIN and COUT as close as possible.
5. A full GND plane without gap break is good for system noise.

PACKAGE INFORMATION

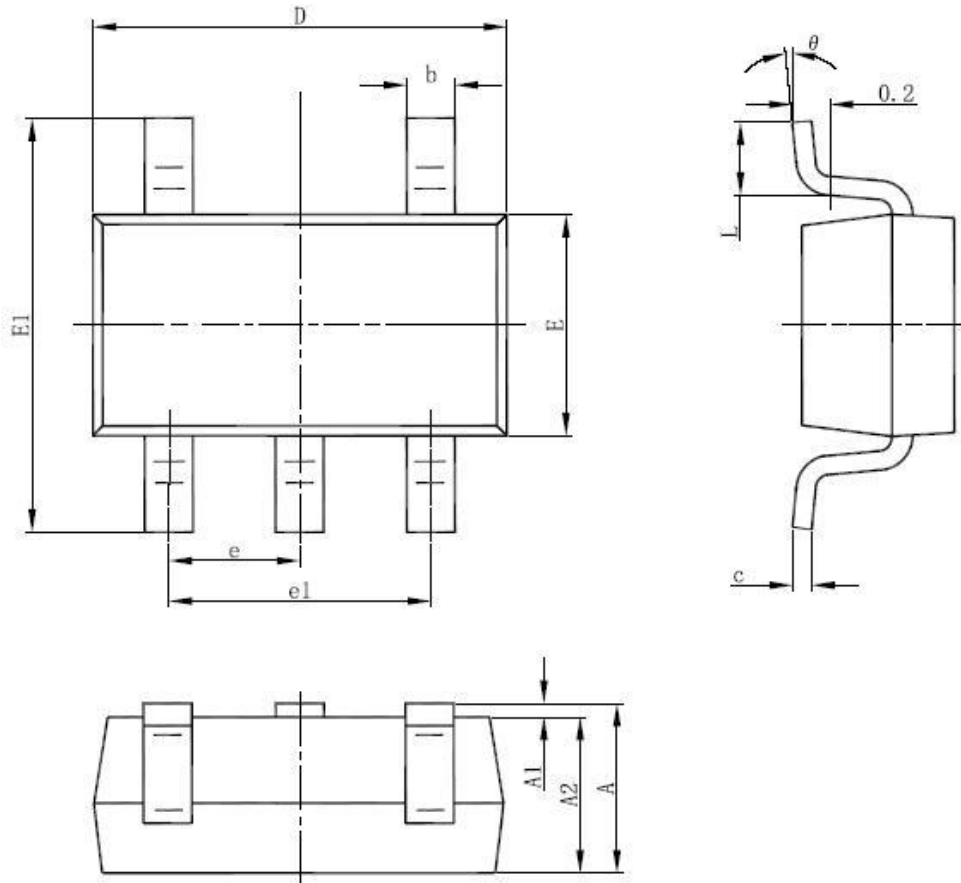

5LD SOT23-5 PACKAGE OUTLINE DIMENSIONS

(All dimensions in mm)

Symbol	Dimensions In Millimeters		Dimensions In Inches	
	Min	Max	Min	Max
A	1.050	1.250	0.041	0.049
A1	0.000	0.100	0.000	0.004
A2	1.050	1.150	0.041	0.045
b	0.300	0.500	0.012	0.020
c	0.100	0.200	0.004	0.008
D	2.820	3.020	0.111	0.119
E	1.500	1.700	0.059	0.067
E1	2.650	2.950	0.104	0.116
e	0.950(BSC)		0.037(BSC)	
e1	1.800	2.000	0.071	0.079
L	0.300	0.600	0.012	0.024
θ	0°	8°	0°	8°