



AN650/A

SERVICE MANUAL

99500-36115-03E

FOREWORD

This manual contains an introductory description on the SUZUKI AN650/A and procedures for its inspection/service and overhaul of its main components. Other information considered as generally known is not included.

Read the GENERAL INFORMATION section to familiarize yourself with the motorcycle and its maintenance. Use this section as well as other sections to use as a guide for proper inspection and service. This manual will help you know the motorcycle better so that you can assure your customers of fast and reliable service.

- * This manual has been prepared on the basis of the latest specifications at the time of publication. If modifications have been made since then, differences may exist between the content of this manual and the actual motorcycle.
- * Illustrations in this manual are used to show the basic principles of operation and work procedures. They may not represent the actual motorcycle exactly in detail.
- * This manual is written for persons who have enough knowledge, skills and tools, including special tools, for servicing SUZUKI motorcycles. If you do not have the proper knowledge and tools, ask your authorized SUZUKI motorcycle dealer to help you.

⚠ WARNING

Inexperienced mechanics or mechanics without the proper tools and equipment may not be able to properly perform the services described in this manual. Improper repair may result in injury to the mechanic and may render the motorcycle unsafe for the rider and passenger.

SUZUKI MOTOR CORPORATION

GROUP INDEX

GENERAL INFORMATION	1
PERIODIC MAINTENANCE	2
ENGINE	3
DRIVE TRAIN	4
CVT	5
FI SYSTEM/ CVT SYSTEM	6
FUEL SYSTEM AND THROTTLE BODY	7
COOLING AND LUBRICATION SYSTEM	8
CHASSIS	9
ELECTRICAL SYSTEM	10
SERVICING INFORMATION	11
EMISSION CONTROL INFORMATION	12

SUPPLEMENTS

<i>AN650K4 ('04-MODEL)</i>	13
<i>AN650/AK5 ('05-MODEL)</i>	14
<i>AN650/AK6 ('06-MODEL)</i>	15
<i>AN650/AK7 ('07 -MODEL)</i>	16
<i>AN650/AK8 ('08-MODEL)</i>	17
<i>WIRING DIAGRAM</i>	18

HOW TO USE THIS MANUAL

TO LOCATE WHAT YOU ARE LOOKING FOR:

1. The text of this manual is divided into sections.
2. The section titles are listed in the GROUP INDEX.
3. Holding the manual as shown at the right will allow you to find the first page of the section easily.
4. The contents are listed on the first page of each section to help you find the item and page you need.

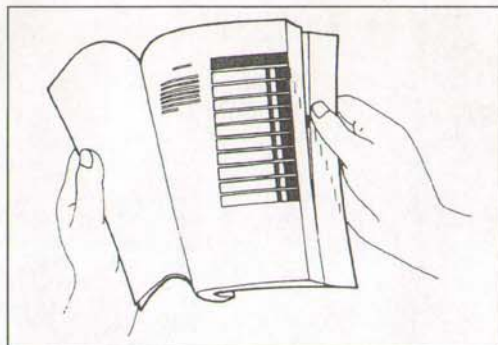

COMPONENT PARTS AND WORK TO BE DONE





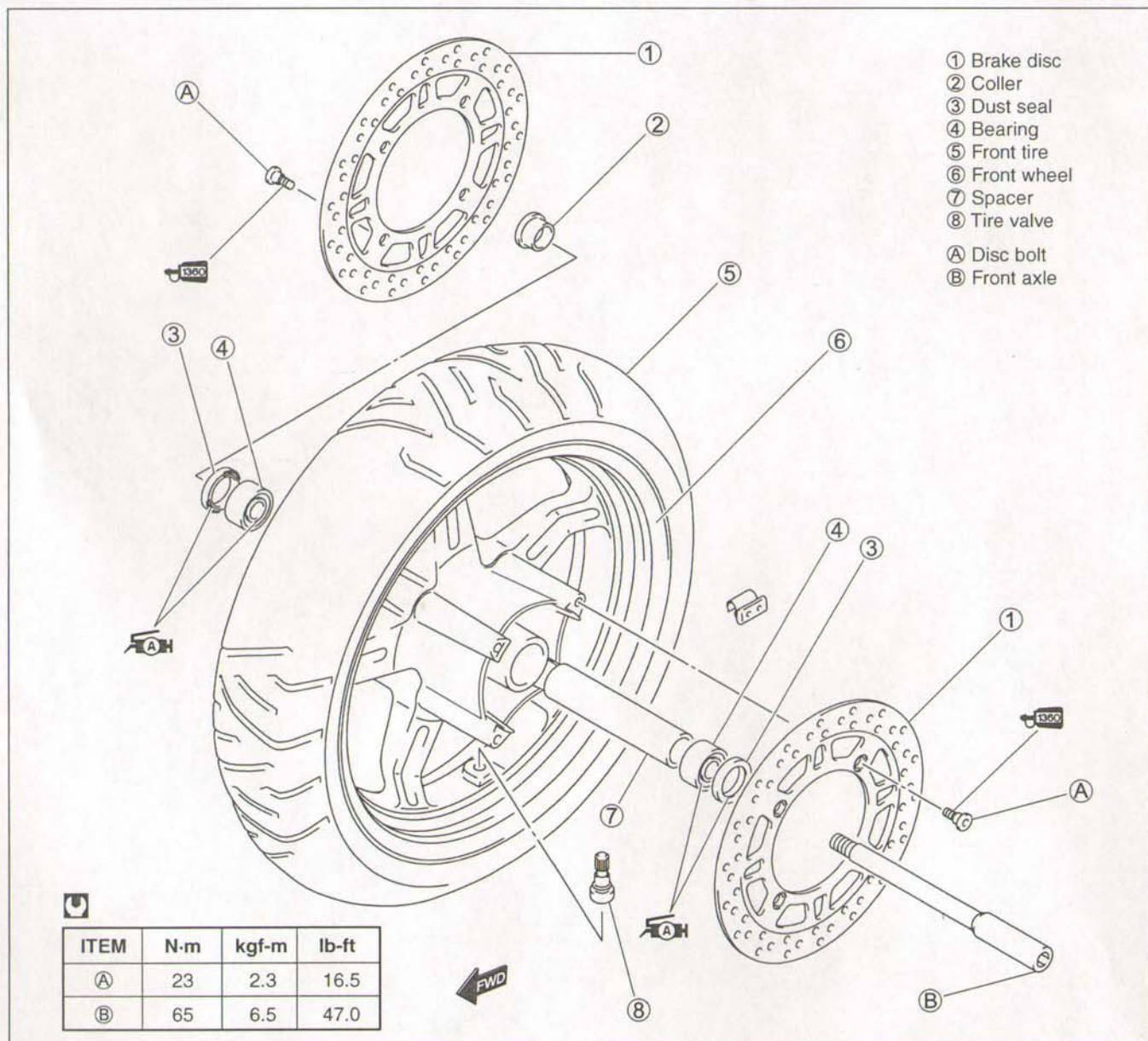













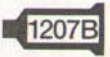

Under the name of each system or unit, is its exploded view. Work instructions and other service information such as the tightening torque, lubricating points and locking agent points, are provided.

Example: Front wheel

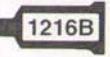

SYMBOL

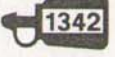
Listed in the table below are the symbols indicating instructions and other information necessary for servicing. The meaning of each symbol is also included in the table.

SYMBOL	DEFINITION	SYMBOL	DEFINITION
	Torque control required. Data beside it indicates specified torque.		Use engine coolant.
	Apply oil. Use engine oil unless otherwise specified.		Use fork oil. 99000-99044-10G
	Apply molybdenum oil solution. (Mixture of engine oil and SUZUKI MOLY PASTE in a ratio of 1 : 1)		Apply or use brake fluid.
	Apply SUZUKI SUPER GREASE "A". 99000-25030		Measure in voltage range.
	Apply SUZUKI MOLY PASTE. 99000-25140		Measure in current range.
	Apply SUZUKI BOND "1207B". 99104-31140 (USA)		Measure in resistance range.
	Apply SUZUKI BOND "1215". 99000-31110 (Except USA)		Measure in diode test range.
	Apply SUZUKI BOND "1216B". 99000-31230		Measure in continuity test range.
	Apply THREAD LOCK SUPER "1303". 99000-32030		Use special tool.
	Apply THREAD LOCK "1342". 99000-32050		Indication of service data.
	Apply THREAD LOCK SUPER "1360". 99000-32130		

ABBREVIATIONS USED IN THIS MANUAL

A

ABDC	: After Bottom Dead Center
AC	: Alternating Current
ACL	: Air Cleaner, Air Cleaner Box
API	: American Petroleum Institute
ATDC	: After Top Dead Center
ATM Pressure:	Atmospheric Pressure
	Atmospheric Pressure Sensor (APS)
A/F	: Air Fuel Mixture

B

BBDC	: Before Bottom Dead Center
BTDC	: Before Top Dead Center
B+	: Battery Positive Voltage

C

CKP Sensor	: Crankshaft Position Sensor (CKPS)
CKT	: Circuit
CLP Switch	: Clutch Lever Position Switch (Clutch Switch)
CMP Sensor	: Camshaft Position Sensor (CMPS)
CO	: Carbon Monoxide
CPU	: Central Processing Unit
CVT Control Unit	: Continuously Variable Transmission Control Unit (TCU)

D

DC	: Direct Current
DMC	: Dealer Mode Coupler
DOHC	: Double Over Head Camshaft
DRL	: Daytime Running Light
DTC	: Diagnostic Trouble Code Malfunction Code

E

ECM	: Engine Control Module Engine Control Unit (ECU) (FI Control Unit)
ECT Sensor	: Engine Coolant Temperature Sensor (ECTS), Water Temp. Sensor (WTS)
EVAP	: Evaporative Emission
EVAP Canister:	Evaporative Emission Canister (Canister)

F

FI	: Fuel Injection, Fuel Injector
FP	: Fuel Pump
FPR	: Fuel Pressure Regulator
FP Relay	: Fuel Pump Relay
FTPC Valve	: Fuel Tank Pressure Control Valve (TPC Valve)

G

GEN	: Generator
GND	: Ground
GP Switch	: Gear Position Switch

H

HC	: Hydrocarbons
HO2S	: Heated Oxygen Sensor

I

IAC Valve	: Idle Air Control Valve
IAP Sensor	: Intake Air Pressure Sensor (IAPS)
IAT Sensor	: Intake Air Temperature Sensor (IATS)
IG	: Ignition

L

LCD	: Liquid Crystal Display
LED	: Light Emitting Diode (Malfunction Indicator Lamp)
LH	: Left Hand

M

MAL-Code : Malfunction Code
(Diagnostic Code)
Max : Maximum
MIL : Malfunction Indicator Lamp
(LED)
Min : Minimum

N

NOx : Nitrogen Oxides

O

OHC : Over Head Camshaft
OLS : Oil Level Switch
OPS : Oil Pressure Switch

P

PCV : Positive Crankcase
Ventilation (Crankcase Breather)

R

RH : Right Hand
ROM : Read Only Memory

S

SAE : Society of Automotive Engineers

T

TO Sensor : Tip Over Sensor (TOS)
TP Sensor : Throttle Position Sensor (TPS)

SAE-TO-FORMER SUZUKI TERM

This table lists SAE (Society of Automotive Engineers) J1930 terms and abbreviations which may be used in this manual in compliance with SAE recommendations, as well as their former SUZUKI names.

SAE TERM		FORMER SUZUKI TERM
FULL TERM	ABBREVIATION	
A		
Air Cleaner	ACL	Air Cleaner, Air Cleaner Box
B		
Barometric Pressure	BARO	Barometric Pressure, Atmospheric Pressure (APS, AP Sensor)
Battery Positive Voltage	B+	Battery Voltage, +B
C		
Camshaft Position Sensor	CMP Sensor	Camshaft Position Sensor (CMPS)
Crankshaft Position Sensor	CKP Sensor	Crankshaft Position Sensor (CKPS), Crank Angle
D		
Data Link Connector	DLC	Dealer Mode Coupler
Diagnostic Test Mode	DTM	—
Diagnostic Trouble Code	DTC	Diagnostic Code, Malfunction Code
E		
Electronic Ignition	EI	—
Engine Control Module	ECM	Engine Control Module (ECM) FI Control Unit, Engine Control Unit (ECU)
Engine Coolant Level	ECL	Coolant Level
Engine Coolant Temperature	ECT	Coolant Temperature, Engine Coolant Temperature Water Temperature
Engine Speed	RPM	Engine Speed (RPM)
Evaporative Emission	EVAP	Evaporative Emission
Evaporative Emission Canister	EVAP Canister	— (Canister)
Exhaust Control System	EXCS	EXC System (EXCS)
Exhaust Control Valve	EXCV	EXC Valve (EXCV)
Exhaust Control Valve Actuator	EXCVA	EXCV Actuator (EXCVA)
Purge Valve	Purge Valve	Purge Valve (SP Valve)
F		
Fan Control	FC	—
Fuel Level Sensor	—	Fuel Level Sensor, Fuel Level Gauge
Fuel Pump	FP	Fuel Pump (FP)

SAE TERM		FORMER SUZUKI TERM
FULL TERM	ABBREVIATION	
G		
Generator	GEN	Generator
Ground	GND	Ground (GND, GRD)
I		
Idle Air Control Valve	IAC Valve	IAC Valve (IACV)
Idle Speed Control	ISC	—
Ignition Control	IC	Electronic Spark Advance (ESA)
Ignition Control Module	ICM	—
Intake Air Temperature	IAT	Intake Air Temperature (IAT), Air Temperature
M		
Malfunction Indicator Lamp	MIL	LED Lamp Malfunction Indicator Lamp (MIL)
Manifold Absolute Pressure	MAP	Intake Air Pressure, Intake Vacuum
Mass Air Flow	MAF	Air Flow
O		
On-Board Diagnostic	OBD	Self-Diagnosis Function Diagnostic
Open Loop	OL	—
P		
Programmable Read Only Memory	PROM	—
Pulsed Secondary Air Injection	PAIR	Pulse Air Control (PAIR)
R		
Random Access Memory	RAM	—
Read Only Memory	ROM	ROM
S		
Secondary Air Injection	AIR	—
Secondary Throttle Control System	STCS	STC System (STCS)
Secondary Throttle Valve	STV	ST Valve (STV)
Secondary Throttle Valve Actuator	STVA	STV Actuator (STVA)
T		
Tank Pressure Control Valve	TPC Valve	TPC Valve (TPCV)
Throttle Body	TB	Throttle Body (TB)
Throttle Body Fuel Injection	TBI	Throttle Body Fuel Injection (TBI)
Throttle Position Sensor	TP Sensor	TP Sensor (TPS)
Transmission Control Module	TCM	CVT Control Unit (TCU)

SAE TERM		FORMER SUZUKI TERM
FULL TERM	ABBREVIATION	
V		
Voltage Regulator	VR	Voltage Regulator
Volume Air Flow	VAF	Air Flow

WIRE COLOR

B : Black	G : Green	P : Pink
Bl : Blue	Gr : Gray	R : Red
Br : Brown	Lbl : Light blue	V : Violet
Dg : Dark green	Lg : Light green	W : White
Dgr : Dark gray	O : Orange	Y : Yellow

B/Bl : Black with Blue tracer	B/Br : Black with Brown tracer
B/G : Black with Green tracer	B/O : Black with Orange tracer
B/R : Black with Red tracer	B/W : Black with White tracer
B/Y : Black with Yellow tracer	Bl/B : Blue with Black tracer
Bl/G : Blue with Green tracer	Bl/R : Blue with Red tracer
Bl/W : Blue with White tracer	Bl/Y : Blue with Yellow tracer
Br/B : Brown with Black tracer	Br/W : Brown with White tracer
G/B : Green with Black tracer	G/Bl : Green with Blue tracer
G/R : Green with Red tracer	G/W : Green with White tracer
G/Y : Green with Yellow tracer	Gr/B : Gray with Black tracer
Gr/R : Gray with Red tracer	Gr/W : Gray with White tracer
Gr/Y : Gray with Yellow tracer	Lg/B : Light green with Black tracer
Lg/Y : Light green with Yellow tracer	O/B : Orange with Black tracer
O/Bl : Orange with Blue tracer	O/G : Orange with Green tracer
O/R : Orange with Red tracer	O/W : Orange with White tracer
O/Y : Orange with Yellow tracer	P/B : Pink with Black tracer
P/W : Pink with White tracer	R/B : Red with Black tracer
R/Bl : Red with Blue tracer	R/G : Red with Green tracer
R/W : Red with White tracer	R/Y : Red with Yellow tracer
W/B : White with Black tracer	W/Bl : White with Blue tracer
W/G : White with Green tracer	W/R : White with Red tracer
W/Y : White with Yellow tracer	Y/B : Yellow with Black tracer
Y/Bl : Yellow with Blue tracer	Y/G : Yellow with Green tracer
Y/R : Yellow with Red tracer	Y/W : Yellow with White tracer

GENERAL INFORMATION**1****CONTENTS**

WARNING/ CAUTION/ NOTE	1- 2
GENERAL PRECAUTIONS	1- 2
SUZUKI AN650K3 ('03-MODEL)	1- 4
SERIAL NUMBER LOCATION	1- 4
FUEL, OIL AND ENGINE COOLANT RECOMMENDATION	1- 4
FUEL (FOR USA AND CANADA)	1- 4
FUEL (FOR OTHER COUNTRIES)	1- 4
ENGINE OIL AND TRANSMISSION OIL (FOR USA)	1- 5
ENGINE OIL AND TRANSMISSION OIL	
(FOR OTHER COUNTRIES)	1- 5
FINAL GEAR OIL	1- 5
BRAKE FLUID	1- 5
FRONT FORK OIL	1- 5
ENGINE COOLANT	1- 5
WATER FOR MIXING	1- 5
ANTI-FREEZE/ENGINE COOLANT	1- 5
LIQUID AMOUNT OF WATER/ENGINE COOLANT	1- 6
BREAK-IN PROCEDURES	1- 7
CYLINDER IDENTIFICATION	1- 7
INFORMATION LABELS	1- 8
SPECIFICATIONS	1- 9
COUNTRY AND AREA CODES	1-11

WARNING/ CAUTION/ NOTE

Please read this manual and follow its instructions carefully. To emphasize special information, the symbol and the words WARNING, CAUTION and NOTE have special meanings. Pay special attention to the messages highlighted by these signal words.

▲ WARNING

Indicates a potential hazard that could result in death or injury.

CAUTION

Indicates a potential hazard that could result in motorcycle damage.

NOTE:

Indicates special information to make maintenance easier or instructions clearer.

Please note, however, that the warnings and cautions contained in this manual cannot possibly cover all potential hazards relating to the servicing, or lack of servicing, of the motorcycle. In addition to the WARNINGS and CAUTIONS stated, you must use good judgement and basic mechanical safety principles. If you are unsure about how to perform a particular service operation, ask a more experienced mechanic for advice.

GENERAL PRECAUTIONS

▲ WARNING

- * Proper service and repair procedures are important for the safety of the service mechanic and the safety and reliability of the motorcycle.
- * When 2 or more persons work together, pay attention to the safety of each other.
- * When it is necessary to run the engine indoors, make sure that exhaust gas is forced outdoors.
- * When working with toxic or flammable materials, make sure that the area you work in is well-ventilated and that you follow all of the material manufacturer's instructions.
- * Never use gasoline as a cleaning solvent.
- * To avoid getting burned, do not touch the engine, engine oil, radiator and exhaust system until they have cooled.
- * After servicing the fuel, oil, water, exhaust or brake systems, check all lines and fittings related to the system for leaks.

CAUTION

- * If parts replacement is necessary, replace the parts with Suzuki Genuine Parts or their equivalent.
 - * When removing parts that are to be reused, keep them arranged in an orderly manner so that they may be reinstalled in the proper order and orientation.
 - * Be sure to use special tools when instructed.
 - * Make sure that all parts used in reassembly are clean. Lubricate them when specified.
 - * Use the specified lubricant, bond, or sealant.
 - * When removing the battery, disconnect the negative cable first and then the positive cable.
 - * When reconnecting the battery, connect the positive cable first and then the negative cable, and replace the terminal cover on the positive terminal.
 - * When performing service to electrical parts, if the service procedures not require use of battery power, disconnect the negative cable the battery.
 - * When tightening the cylinder head and case bolts and nuts, tighten the larger sizes first. Always tighten the bolts and nuts diagonally from the inside toward outside and to the specified tightening torque.
 - * Whenever you remove oil seals, gaskets, packing, O-rings, locking washers, self-locking nuts, cotter pins, circlips and certain other parts as specified, be sure to replace them with new ones. Also, before installing these new parts, be sure to remove any left over material from the mating surfaces.
 - * Never reuse a circlip. When installing a new circlip, take care not to expand the end gap larger than required to slip the circlip over the shaft. After installing a circlip, always ensure that it is completely seated in its groove and securely fitted.
 - * Use a torque wrench to tighten fasteners to the specified torque. Wipe off grease and oil if a thread is smeared with them.
 - * After reassembling, check parts for tightness and proper operation.
-
- * To protect the environment, do not unlawfully dispose of used motor oil, engine coolant and other fluids: batteries, and tires.
 - * To protect Earth's natural resources, properly dispose of used motorcycle and parts.

SUZUKI AN650K3 ('03-MODEL)



RIGHT SIDE



LEFT SIDE

* Difference between photographs and actual motorcycles depends on the markets.

SERIAL NUMBER LOCATION

The frame serial number or V.I.N. (Vehicle Identification Number) ① is stamped on the right side of the frame down tube. The engine serial number ② is located on the left side of the crankcase. These numbers are required especially for registering the machine and ordering spare parts.

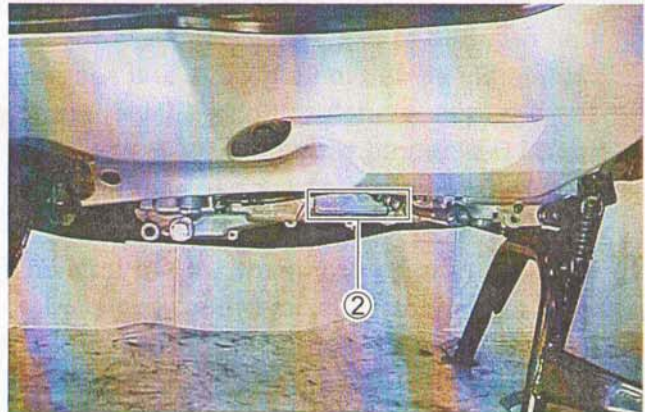
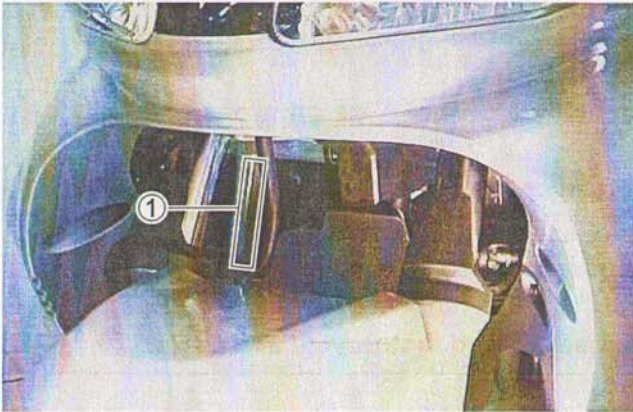

FUEL, OIL AND ENGINE COOLANT RECOMMENDATION

FUEL (FOR USA AND CANADA)

Use only unleaded gasoline of at least 87 pump octane ($\frac{R+M}{2}$) or 91 octane or higher rated by the research method.

Gasoline containing MTBE (Methyl Tertiary Butyl Ether), less than 10% ethanol, or less than 5% methanol with appropriate cosolvents and corrosion inhibitor is permissible.

FUEL (FOR OTHER COUNTRIES)

Gasoline used should be graded 91 octane (Research Method) or higher. Unleaded gasoline is recommended.

LIQUID AMOUNT OF WATER/ENGINE COOLANT

Solution capacity (total): 1 300 ml (1.4/1.1 US/Imp qt)

For engine coolant mixture information, refer to cooling system section, page 8-3.

CAUTION

Mixing of anti-freeze/engine coolant should be limited to 60%. Mixing beyond it would reduce its efficiency. If the anti-freeze/engine coolant mixing ratio is below 50%, rust inhabiting performance is greatly reduced. Be sure to mix it above 50% even though the atmospheric temperature does not go down to the freezing point.

BREAK-IN PROCEDURES

During manufacture only the best possible materials are used and all machined parts are finished to a very high standard but it is still necessary to allow the moving parts to "BREAK-IN" before subjecting the engine to maximum stresses. The future performance and reliability of the engine depends on the care and restraint exercised during its early life. The general rules are as follows.

- Keep to these break-in engine speed limits:

Initial 800 km (500 miles): Below 4 000 r/min

Up to 1 600 km (1 000 miles): Below 6 000 r/min

Over 1 600 km (1 000 miles): Below 8 500 r/min

- Upon reaching an odometer reading of 1 600 km (1 000 miles) you can subject the motorcycle to full throttle operation. However, do not exceed 8 500 r/min at any time.

CYLINDER IDENTIFICATION

The two cylinders of this engine are identified as No.1 and No.2 cylinder, as counted from left to right (as viewed by the rider on the seat).

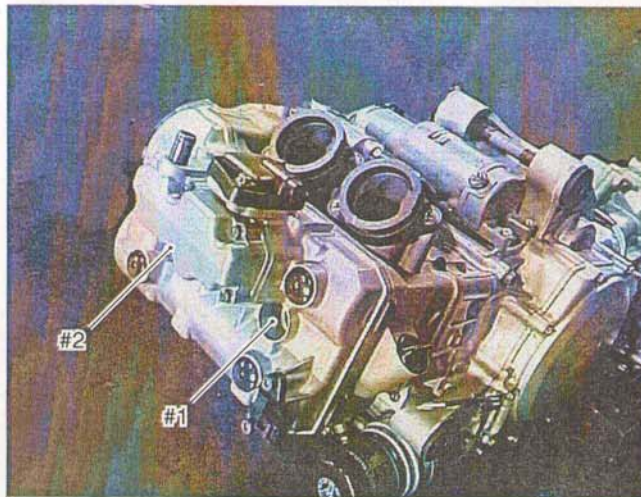

INFORMATION LABELS

①	Warning safety label
②	Engine starting label
③	Screen warning label
④	Tire pressure label
⑤	Fuel information label
⑥	Front box loading capacity label
⑦	Trunk box loading capacity label
⑧	ID label
⑨	Noise label
⑩	Manual notice label
⑪	Safety plate
⑫	Information label
⑬	Oil information label
⑭	EVAP canister hose routing label

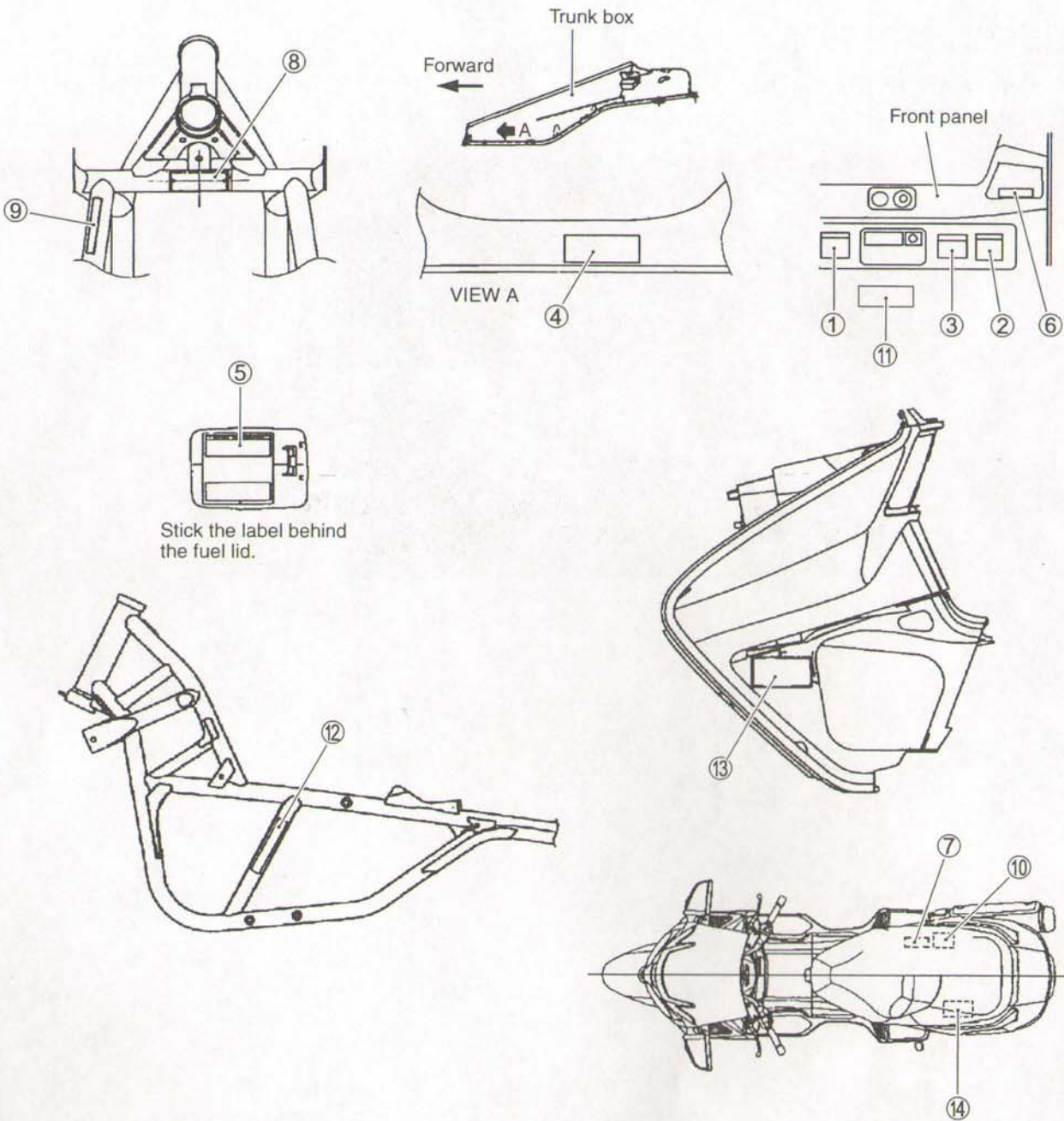

SPECIFICATIONS

DIMENSIONS AND DRY MASS

Overall length	2 260 mm (89.0 in)
Overall width	810 mm (31.9 in)
Overall height	1 430 mm (56.3 in)
Wheelbase	1 595 mm (62.8 in)
Ground clearance	125 mm (4.9 in)
Seat height	750 mm (29.5 in)
Dry mass	238 kg (394 lbs)

ENGINE

Type	Four-stroke, Liquid-cooled, DOHC
Number of cylinders	2
Bore	75.5 mm (2.972 in)
Stroke	71.3 mm (2.807 in)
Piston displacement	638 cm ³ (38.9 cu. in)
Compression ratio	11.2 : 1
Fuel system	Fuel injection system
Air cleaner	Non-woven fabric element
Starter system	Electric starter
Lubrication system	Wet sump

DRIVE TRAIN

Clutch	Wet multi-plate automatic, centrifugal type
Gearshift pattern	Automatic & Manual shift
Automatic transmission ratio	Variable change (1.800 – 0.465)
Final reduction ratio	1.580 (32/31 × 31/32 × 34/31 × 49/34)
Drive system	Gear drive

CHASSIS

Front suspension	Telescopic, coil spring, oil damped
Rear suspension	Swingarm type, coil spring, oil damped
Steering angle	41° (right & left)
Caster	26°
Trail	102 mm (4.0 in)
Turning radius	2.7 m (8.9 ft)
Front brake	Disc brake, twin
Rear brake	Disc brake
Front tire size	120/70 R15M/C 56H, tubeless
Rear tire size	160/60 R14M/C 65H, tubeless
Front fork stroke	105 mm (4.1 in)
Rear wheel travel	100 mm (3.9 in)

ELECTRICAL

Ignition type.....	Electronic ignition (ECM, Transistorized)
Ignition timing.....	10° B. T. D. C at 1 200 r/min
Spark plug.....	NGK: CR8E or DENSO: U24ESR-N
Battery.....	12 V 43.2 kC (12 Ah)/10 HR
Generator.....	Three-phase A.C. Generator
Main fuse	40 A
CVT fuse	40 A
Fuse	15/15/15/15/10/10/10 A
Headlight.....	12 V 60/55 W + 55 W (H4 + H7) E-02, 19 12 V 60/55W × 2 (H4)E-03, 24, 28, 33
Position light.....	12 V 5 W × 2 E-02, 19
Turn signal light.....	12 V 21 W
License light.....	12 V 5 W
Brake light/Taillight.....	12 V 21/5 W × 2
Speedometer light.....	12 V 1.4 W × 2
Power mode indicator light.....	12 V 1.4 W
Drive indicator light	12 V 1.4 W
High beam indicator light	12 V 1.4 W
Turn signal indicator light.....	12 V 1.4 W
Brake-lock indicator light.....	12 V 1.4 W
Fuel injector indicator light	12 V 1.4 W
Engine coolant temperature indicator light.....	12 V 1.4 W
Oil pressure indicator light	12 V 1.4 W
Gear position indicator light	12 V 1.4 W × 5

CAPACITIES

Fuel tank, including reserve	15.0 L (4.0/3.3 US/Imp gal)
Engine oil, oil change	2 600 ml (2.7/2.3 US/Imp qt)
with filter change	2 900 ml (3.1/2.6 US/Imp qt)
overhaul.....	3 400 ml (3.6/3.0 US/Imp qt)
Transmission oil, oil change	360 ml (12.2/12.7 US/Imp oz)
overhaul.....	400 ml (13.5/14.1 US/Imp oz)
Final gear oil, oil change	300 ml (10.1/10.6 US/Imp oz)
overhaul.....	430 ml (14.5/15.1 US/Imp oz)
Engine coolant, including reserve	1 300 ml (1.4/1.1 US/Imp qt)
Front fork oil (each leg)	482 ml (16.3/17.0 US/Imp oz)

These specifications are subject to change without notice.

COUNTRY AND AREA CODES

The following codes stand for the applicable country(-ies) and area(-s).

CODE	COUNTRY or AREA
E-02	U. K.
E-03	U. S. A. (Except for California)
E-19	EU
E-24	Australia
E-28	Canada
E-33	California (U. S. A.)

PERIODIC MAINTENANCE

2

CONTENTS

PERIODIC MAINTENANCE SCHEDULE	2- 2
PERIODIC MAINTENANCE CHART	2- 2
LUBRICATION POINTS	2- 3
MAINTENANCE AND TUNE-UP PROCEDURES	2- 4
AIR CLEANER	2- 4
SPARK PLUG	2- 6
TAPPET CLEARANCE	2- 7
FUEL HOSE	2-13
ENGINE OIL AND OIL FILTER	2-13
TRANSMISSION OIL	2-15
FINAL GEAR OIL	2-15
CVT FILTER	2-16
ENGINE IDLE SPEED	2-18
THROTTLE CABLE PLAY	2-18
THROTTLE VALVE SYNCHRONIZATION	2-19
PAIR (AIR SUPPLY) SYSTEM	2-19
EVAPORATIVE EMISSION CONTROL SYSTEM	2-19
COOLING SYSTEM	2-20
BRAKE	2-22
TIRE	2-25
STEERING	2-26
FRONT FORK	2-26
REAR SUSPENSION	2-27
EXHAUST PIPE BOLT AND MUFFLER MOUNTING BOLT	2-27
CHASSIS BOLT AND NUT	2-28
COMPRESSION PRESSURE CHECK	2-30
COMPRESSION TEST PROCEDURE	2-30
OIL PRESSURE CHECK	2-31
OIL PRESSURE TEST PROCEDURE	2-31
AUTOMATIC CLUTCH INSPECTION	2-32
1. INITIAL ENGAGEMENT INSPECTION	2-32
2. CLUTCH "LOCK-UP" INSPECTION	2-32
BRAKE-LOCK INSPECTION	2-33

PERIODIC MAINTENANCE SCHEDULE

The chart below lists the recommended intervals for all the required periodic service work necessary to keep the motorcycle operating at peak performance and economy. Mileages are expressed in terms of kilometers, miles and time for your convenience.

IMPORTANT: The periodic maintenance intervals and service requirements have been established in accordance with EPA regulations. Following these instructions will ensure that the motorcycle will not exceed emission standards and it will also ensure the reliability and performance of the motorcycle.

NOTE:

More frequent servicing may be performed on motorcycles that are used under severe conditions.

PERIODIC MAINTENANCE CHART

Item	Interval	km	1 000	6 000	12 000	18 000	24 000
		miles	600	4 000	7 500	11 000	14 500
		months	1	6	12	18	24
Air cleaner			—	I	I	R	I
Exhaust pipe bolts and muffler bolts			T	—	T	—	T
Tappet clearance			—	—	—	—	I
Spark plugs			—	I	R	I	R
Fuel hose			—	I	I	I	I
			Replace every 4 years.				
Engine oil			R	R	R	R	R
Engine oil filter			R	—	—	R	—
Transmission oil			R	I	R	I	R
Final gear oil			R	—	R	—	R
CVT filter			—	—	I	—	I
Idle speed			I	I	I	I	I
Throttle cable play			I	I	I	I	I
Throttle valve synchronization			I E-33 only	—	I	—	I
Evaporative emission control system E-33 (California) model only			—	—	I	—	I
			Replace vapor hose every 4 years.				
PAIR (air supply) system			—	—	I	—	I
Engine coolant			Replace every 2 years.				
Radiator hose			—	I	I	I	I
Brakes			I	I	I	I	I
Brake hose			—	I	I	I	I
			Replace every 4 years.				
Brake fluid			—	I	I	I	I
			Replace every 2 years.				
Tires			—	I	I	I	I
Steering			I	—	I	—	I
Front forks			—	—	I	—	I
Rear suspension			—	—	I	—	I
Chassis bolts and nuts			T	T	T	T	T

NOTE:

I=Inspect and clean, adjust, replace or lubricate as necessary;

R=Replace; T=Tighten

LUBRICATION POINTS

Proper lubrication is important for smooth operation and long life of each working part of the motorcycle. Major lubrication points are indicated below.

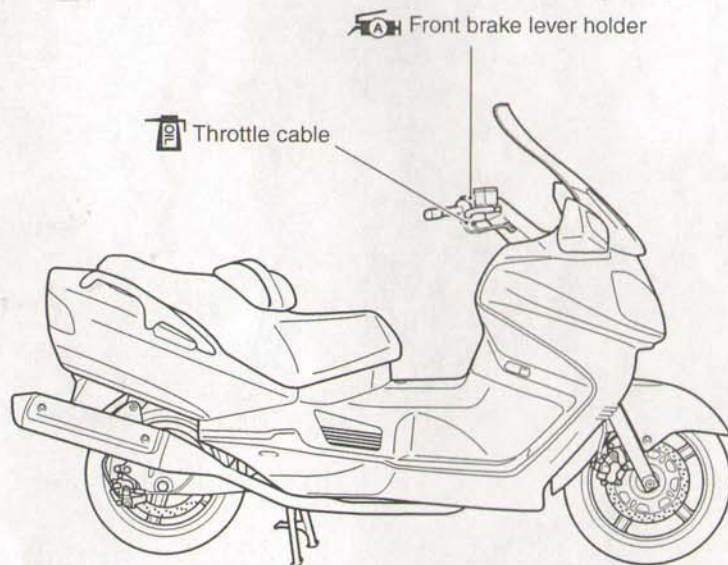
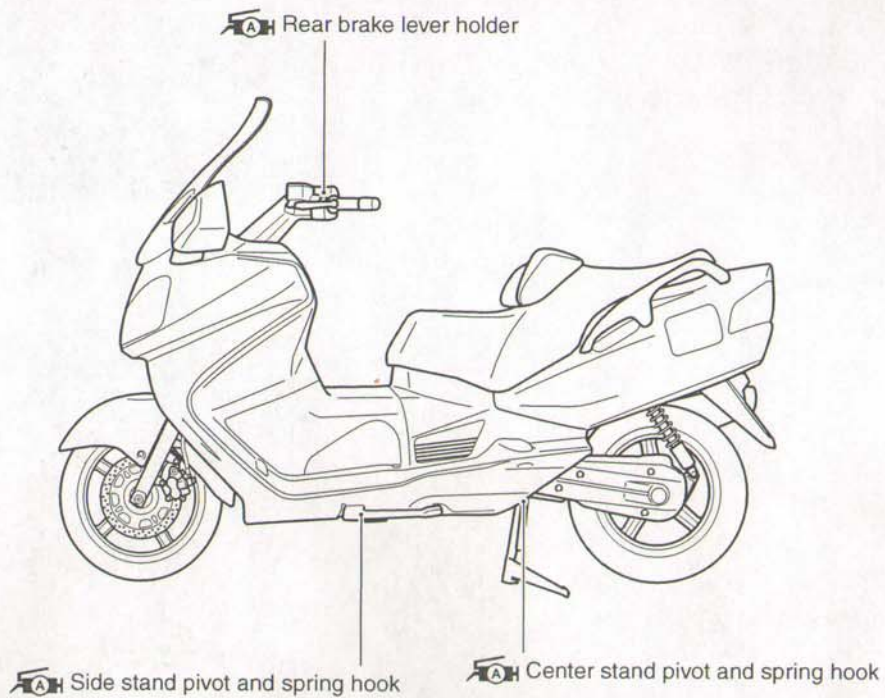

NOTE:

- * Before lubricating each part, clean off any rusty spots and wipe off any grease, oil, dirt or grime.
- * Lubricate exposed parts which are subject to rust, with a rust preventative spray whenever the motorcycle has been operated under wet or rainy conditions.

MAINTENANCE AND TUNE-UP PROCEDURES

This section describes the servicing procedures for each item of the Periodic Maintenance requirements.

AIR CLEANER

Inspect every 6 000 km (4 000 miles, 6 months) and replace every 18 000 km (11 000 miles, 18 months).

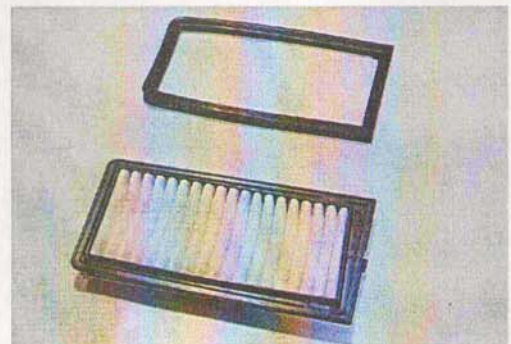
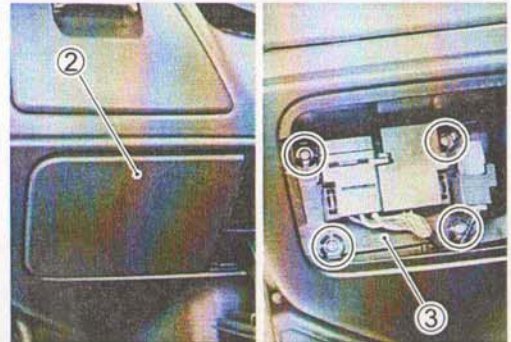
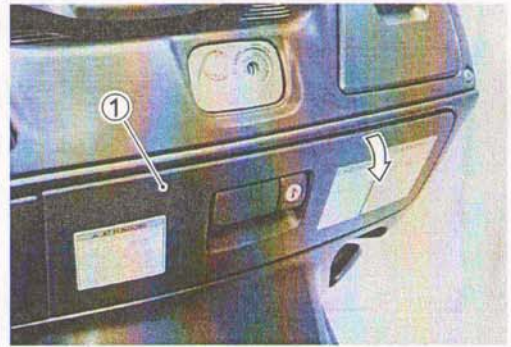

- Open the front box ①.
- Remove the air cleaner box lid ②.
- Remove the air cleaner element lid ③.

- Remove the air cleaner element ④.

- Inspect the air cleaner element and O-ring for damage. If any defects are found, the air cleaner element and O-ring must be replaced.

- Carefully use air hose to blow the dust from the cleaner element.

CAUTION

Always use air pressure on the throttle body side of the air cleaner element. If air pressure is used on the other side, dirt will be forced into the pores of the air cleaner element thus restricting air flow through the air cleaner element.

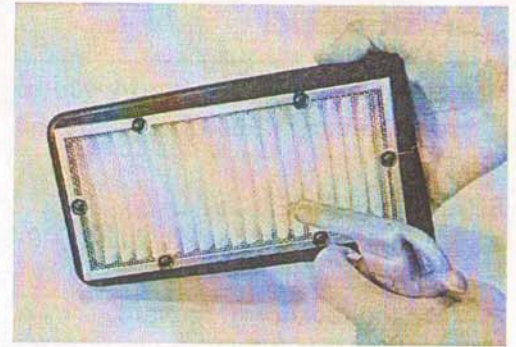

- Install the O-ring ⑤ properly.
- Reinstall the cleaned or new air cleaner element in the reverse order of removal.

CAUTION

If driving under dusty condition, clean the air cleaner element more frequently. The surest way to accelerate engine wear is to use the engine without the element or to use a ruptured element. Make sure that the air cleaner is in good condition at all times. Life of the engine depends largely on this component!

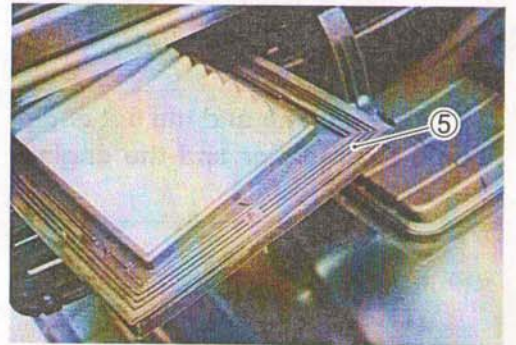

NOTE:

When cleaning the air cleaner element, drain water from the air cleaner by removing the drain plug.

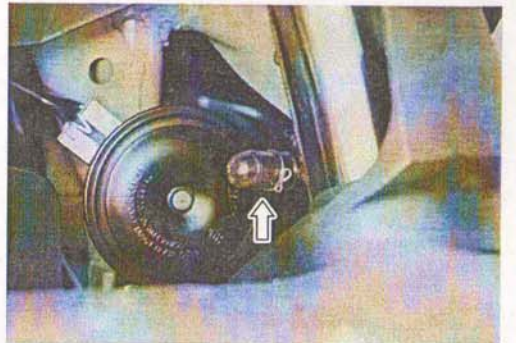

SPARK PLUG

Inspect every 6 000 km (4 000 miles, 6 months) and replace every 12 000 km (7 500 miles, 12 months).

SPARK PLUG REMOVAL

- Remove the lower leg shield. (☞ 9-10)
- Remove the bolt.
- Move the radiator ① forward.

NOTE:

Be careful not to damage the radiator fins.

⚠ WARNING

The hot radiator and the hot engine can burn you. Wait until the radiator and the engine are cool enough to touch.

- Remove the ignition coil/plug caps ②.

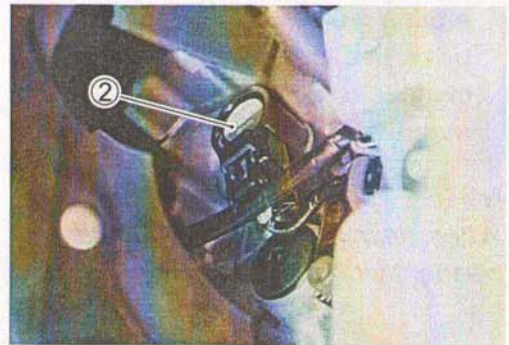
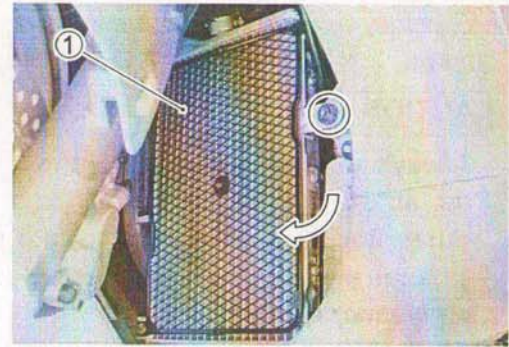

- Remove the spark plugs with the spark plug wrench.



HEAT RANGE

- Check to see the heat range of the plug.

	Standard	Cold type	Hot type
NGK	CR8E	CR9E	CR7E
DENSO	U24ESR-N	U27ESR-N	U22ESR-N

CARBON DEPOSIT

- Check to see if there are carbons deposit on the plugs. If carbon is deposited, remove it with a spark plug cleaner machine or carefully using a tool with a pointed end.

SPARK PLUG GAP

- Measure the plug gap with a thickness gauge. If out of specification, adjust it to the following gap.

TOOL 09900-20803: Thickness gauge

DATA Spark plug gap
Standard: 0.7 – 0.8 mm (0.028 – 0.031 in)

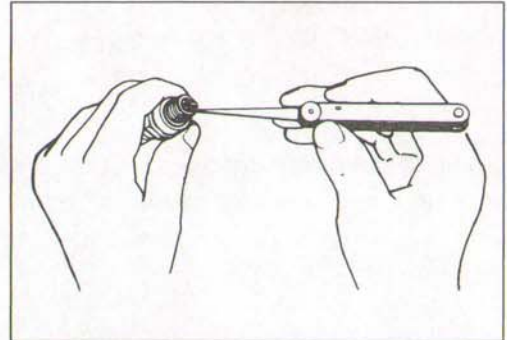

ELECTRODES CONDITION

- Check to see the worn or burnt condition of the electrodes. If it is extremely worn or burnt, replace the plug. And also replace the plug if it has a broken insulator, damaged thread.

CAUTION

Confirm the thread size and reach when replacing the plug. If the reach is too short, carbon will be deposited on the screw portion of the plug hole and engine damage may result.

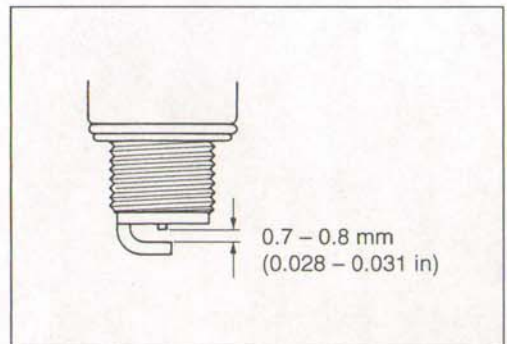

SPARK PLUG INSTALLATION

CAUTION

Before tightening the spark plug to the specified torque, carefully turn the spark plug by finger into the threads of the cylinder head to prevent damage the aluminum threads.

- Install the spark plugs to the cylinder heads by finger tight, and then tighten them to the specified torque.

U Spark plug: 11 N·m (1.1 kgf·m, 8.0 lb-ft)



TAPPET CLEARANCE

Inspect every 24 000 km (14 500 miles, 24 months).

- Remove the front box. (☞ 9-18)
- Remove the foot board. (☞ 9-18)
- Remove the radiator. (☞ 8-6)
- Remove the spark plugs. (☞ 2-6)
- Remove the cylinder head cover ①.

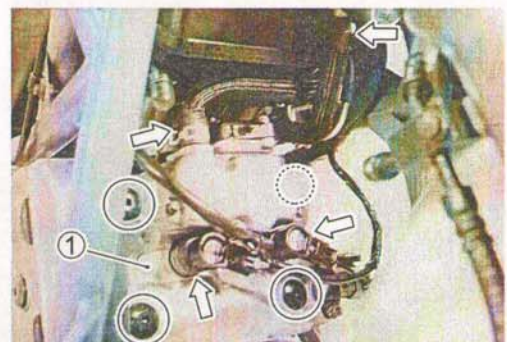

The tappet clearance specification is different for intake and exhaust valves. Tappet clearance must be checked and adjusted, 1) at the time of periodic inspection, 2) when the valve mechanism is serviced, and 3) when the camshafts are removed for servicing.

DATA Tappet clearance (when cold):

Standard: IN. : 0.10 – 0.20 mm (0.004 – 0.008 in)

EX.: 0.20 – 0.30 mm (0.008 – 0.012 in)

NOTE:

- * The clearance specification is for COLD state.
- * To turn the crankshaft for clearance checking, be sure to use a wrench, and rotate in the normal running direction. All spark plugs should be removed.

- Remove the valve timing inspection cap ②.

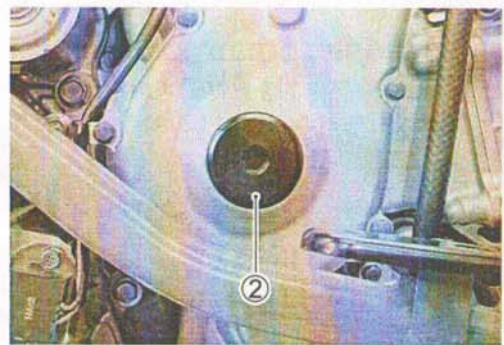

- Turn the crankshaft to bring the "Top" line on the starter clutch to the index mark and also to align the notches (A) on the both ends of each camshaft with "1" mark (B) on the exhaust sprocket to the positions as shown.

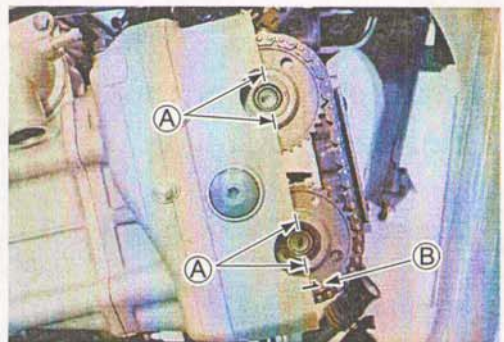
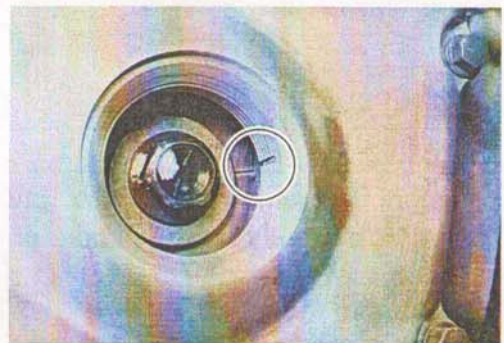

- In this condition, read the tappet clearance at the valves (In and Ex of No.2).
- If the clearance is out of specification, adjust the clearance as shown below.

 **09900-20803: Thickness gauge**

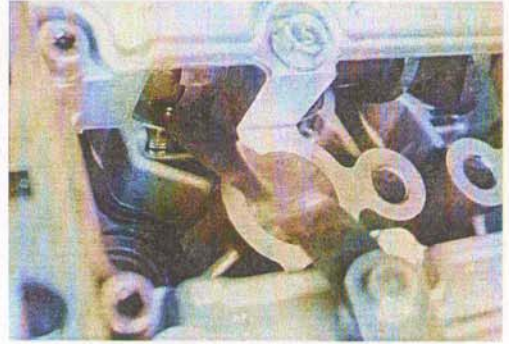

- Turn the crankshaft 360 degrees (one rotation) to bring the "TOP" line on the starter clutch to the index mark of valve timing inspection hole and also to bring notches (A) to the position as shown.
- Read the clearance at the remaining valves (In and Ex of No.1) and adjust the clearance if necessary as shown below.

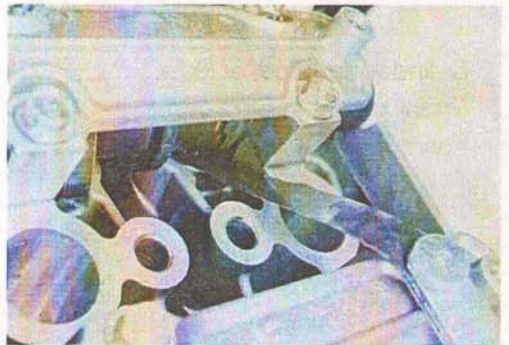
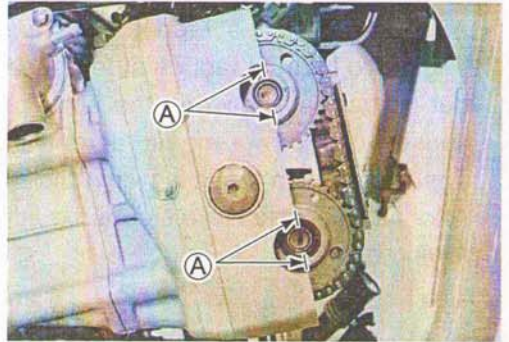

TAPPET CLEARANCE ADJUSTMENT

The clearance is adjusted by replacing the existing tappet shim by a thicker or thinner shim.

- Remove the intake or exhaust camshafts. (☞ 3-12)
- Remove the tappet ① and shim ② by fingers or magnetic hand.
- Check the figures printed on the shim. These figures indicate the thickness of the shim, as illustrated.
- Select a replacement shim that will provide a clearance within the specified range. For the purpose of this adjustment, a total of 25 sizes of tappet shim are available ranging from 1.20 to 2.20 mm in steps of 0.05 mm. Fit the selected shim to the valve stem end, with numbers toward tappet. Be sure to check shim size with micrometer to ensure its size. Refer to the tappet shim selection table (Pages 2-11 and 2-12) for details.

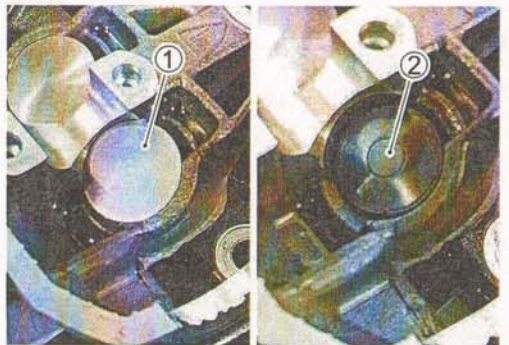

NOTE:

- * Be sure to apply engine oil to tappet shim top and bottom faces.
- * When seating the tappet shim, be sure to face figure printed surface to the tappet.

CAUTION

Reinstall the camshafts as the specified manner.
 (☞ 3-72)

- After replacing the tappet shim and camshafts, rotate the engine so that the tappet is depressed fully. This will squeeze out oil trapped between the shim and the tappet that could cause an incorrect measurement, then check the clearance again to confirm that it is within the specified range.
- After finishing the valve clearance adjustment, reinstall the following items.

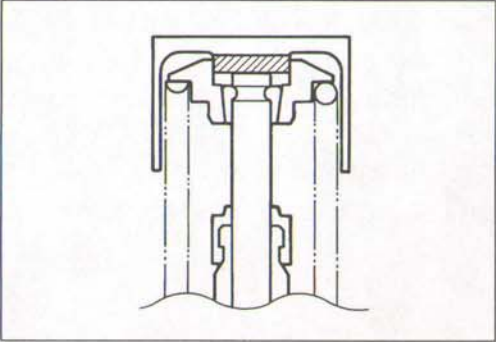
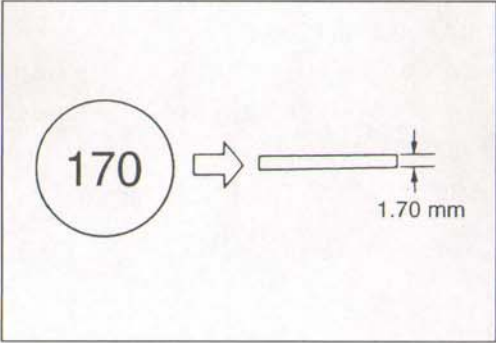

Page

- * Cylinder head cover3-74
- * Spark plug and plug cap2-6
- * Valve timing inspection plug2-8

(INTAKE SIDE)

TAPPET SHIM SELECTION TABLE [INTAKE]
TAPPET SHIM NO. (12892-05C00-XXX)

TAPPET SHIM SET (12800-05820)

MEASURED TAPPET CLEARANCE (mm)	SUFFIX NO.	PRESENT SHIM SIZE (mm)	SPECIFIED CLEARANCE/NO. ADJUSTMENT REQUIRED																				
			120	125	130	135	140	145	150	155	160	165	170	175	180	185	190	195	200	205	210	215	220
0.00-0.04		1.20	1.20	1.25	1.30	1.35	1.40	1.45	1.50	1.55	1.60	1.65	1.70	1.75	1.80	1.85	1.90	1.95	2.00	2.05	2.10	2.15	2.20
0.05-0.09		1.20	1.20	1.25	1.30	1.35	1.40	1.45	1.50	1.55	1.60	1.65	1.70	1.75	1.80	1.85	1.90	1.95	2.00	2.05	2.10	2.15	2.20
0.10-0.20		1.20	1.25	1.30	1.35	1.40	1.45	1.50	1.55	1.60	1.65	1.70	1.75	1.80	1.85	1.90	1.95	2.00	2.05	2.10	2.15	2.20	
0.21-0.25		1.30	1.35	1.40	1.45	1.50	1.55	1.60	1.65	1.70	1.75	1.80	1.85	1.90	1.95	2.00	2.05	2.10	2.15	2.20			
0.26-0.30		1.35	1.40	1.45	1.50	1.55	1.60	1.65	1.70	1.75	1.80	1.85	1.90	1.95	2.00	2.05	2.10	2.15	2.20				
0.31-0.35		1.40	1.45	1.50	1.55	1.60	1.65	1.70	1.75	1.80	1.85	1.90	1.95	2.00	2.05	2.10	2.15	2.20					
0.36-0.40		1.45	1.50	1.55	1.60	1.65	1.70	1.75	1.80	1.85	1.90	1.95	2.00	2.05	2.10	2.15	2.20						
0.41-0.45		1.50	1.55	1.60	1.65	1.70	1.75	1.80	1.85	1.90	1.95	2.00	2.05	2.10	2.15	2.20							
0.46-0.50		1.55	1.60	1.65	1.70	1.75	1.80	1.85	1.90	1.95	2.00	2.05	2.10	2.15	2.20								
0.51-0.55		1.60	1.65	1.70	1.75	1.80	1.85	1.90	1.95	2.00	2.05	2.10	2.15	2.20									
0.56-0.60		1.65	1.70	1.75	1.80	1.85	1.90	1.95	2.00	2.05	2.10	2.15	2.20										
0.61-0.65		1.70	1.75	1.80	1.85	1.90	1.95	2.00	2.05	2.10	2.15	2.20											
0.66-0.70		1.75	1.80	1.85	1.90	1.95	2.00	2.05	2.10	2.15	2.20												
0.71-0.75		1.80	1.85	1.90	1.95	2.00	2.05	2.10	2.15	2.20													
0.76-0.80		1.85	1.90	1.95	2.00	2.05	2.10	2.15	2.20														
0.81-0.85		1.90	1.95	2.00	2.05	2.10	2.15	2.20															
0.86-0.90		1.95	2.00	2.05	2.10	2.15	2.20																
0.91-0.95		2.00	2.05	2.10	2.15	2.20																	
0.96-1.00		2.05	2.10	2.15	2.20																		
1.01-1.05		2.10	2.15	2.20																			
1.06-1.10		2.15	2.20																				
1.11-1.15		2.20																					

HOW TO USE THIS CHART:

- I. Measure tappet clearance. "ENGINE IS COLD"
- II. Measure present shim size.
- III. Match clearance in vertical column with present shim size in horizontal column.

EXAMPLE

Tappet clearance is 0.23 mm
Present shim size 1.70 mm
Shim size to be used 1.80 mm

(EXHAUST SIDE)

TAPPET SHIM SELECTION TABLE [EXHAUST]
TAPPET SHIM NO. (12892-05C00-XXX)

TAPPET SHIM SET (12800-05820)

MEASURED TAPPET CLEARANCE (mm)	SUFFIX NO.	PRESENT SHIM SIZE (mm)	SPECIFIED CLEARANCE/NO. ADJUSTMENT REQUIRED																							
			120	125	130	135	140	145	150	155	160	165	170	175	180	185	190	195	200	205	210	215	220			
0.05-0.09		1.20				1.20	1.25	1.30	1.35	1.40	1.45	1.50	1.55	1.60	1.65	1.70	1.75	1.80	1.85	1.90	1.95	2.00	2.05	2.10	2.15	2.20
0.10-0.14		1.20	1.20	1.25	1.30	1.35	1.40	1.45	1.50	1.55	1.60	1.65	1.70	1.75	1.80	1.85	1.90	1.95	2.00	2.05	2.10	2.15	2.20			
0.15-0.19		1.20	1.20	1.25	1.30	1.35	1.40	1.45	1.50	1.55	1.60	1.65	1.70	1.75	1.80	1.85	1.90	1.95	2.00	2.05	2.10	2.15	2.20			
0.20-0.30		1.30	1.35	1.40	1.45	1.50	1.55	1.60	1.65	1.70	1.75	1.80	1.85	1.90	1.95	2.00	2.05	2.10	2.15	2.20						
0.31-0.35		1.35	1.40	1.45	1.50	1.55	1.60	1.65	1.70	1.75	1.80	1.85	1.90	1.95	2.00	2.05	2.10	2.15	2.20							
0.36-0.40		1.40	1.45	1.50	1.55	1.60	1.65	1.70	1.75	1.80	1.85	1.90	1.95	2.00	2.05	2.10	2.15	2.20								
0.41-0.45		1.45	1.50	1.55	1.60	1.65	1.70	1.75	1.80	1.85	1.90	1.95	2.00	2.05	2.10	2.15	2.20									
0.46-0.50		1.50	1.55	1.60	1.65	1.70	1.75	1.80	1.85	1.90	1.95	2.00	2.05	2.10	2.15	2.20										
0.51-0.55		1.55	1.60	1.65	1.70	1.75	1.80	1.85	1.90	1.95	2.00	2.05	2.10	2.15	2.20											
0.56-0.60		1.60	1.65	1.70	1.75	1.80	1.85	1.90	1.95	2.00	2.05	2.10	2.15	2.20												
0.61-0.65		1.65	1.70	1.75	1.80	1.85	1.90	1.95	2.00	2.05	2.10	2.15	2.20													
0.66-0.70		1.70	1.75	1.80	1.85	1.90	1.95	2.00	2.05	2.10	2.15	2.20														
0.71-0.75		1.75	1.80	1.85	1.90	1.95	2.00	2.05	2.10	2.15	2.20															
0.76-0.80		1.80	1.85	1.90	1.95	2.00	2.05	2.10	2.15	2.20																
0.81-0.85		1.85	1.90	1.95	2.00	2.05	2.10	2.15	2.20																	
0.86-0.90		1.90	1.95	2.00	2.05	2.10	2.15	2.20																		
0.91-0.95		1.95	2.00	2.05	2.10	2.15	2.20																			
0.96-1.00		2.00	2.05	2.10	2.15	2.20																				
1.01-1.05		2.05	2.10	2.15	2.20																					
1.06-1.10		2.10	2.15	2.20																						
1.11-1.15		2.15	2.20																							
1.16-1.20		2.20																								
1.21-1.25																										

HOW TO USE THIS CHART:

- I. Measure tappet clearance. "ENGINE IS COLD"
- II. Measure present shim size.
- III. Match clearance in vertical column with present shim size in horizontal column.

EXAMPLE

Tappet clearance is 0.33 mm
Present shim size 1.70 mm
Shim size to be used 1.80 mm

FUEL HOSE

Inspect every 6 000 km (4 000 miles, 6 months).
Replace every 4 years.

Inspect the fuel feed hose **A** for damage and fuel leakage. If any defects are found, the fuel hoses must be replaced.

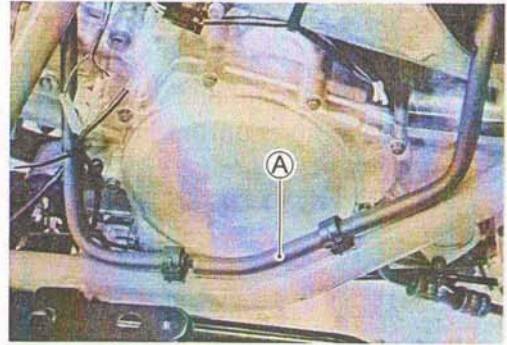

ENGINE OIL AND OIL FILTER

(ENGINE OIL)

Replace initially at 1 000 km (600 miles, 1 month) and every 6 000 km (4 000 miles, 6 months) thereafter.

(OIL FILTER)

Replace initially at 1 000 km (600 miles, 1 month) and every 18 000 km (11 000 miles, 18 months) thereafter.

Oil should be changed while the engine is warm. Oil filter replacement at the above intervals, should be done together with the engine oil change.

ENGINE OIL REPLACEMENT

- Keep the motorcycle upright with the center stand.
 - Remove the maintenance lid. (☞ 9-13)
 - Place an oil pan below the engine, and drain oil by removing the drain plug **1** and filler cap **2**.
-
- Tighten the drain plug **1** to the specified torque, and pour fresh oil through the oil filler. The engine will hold about 2.6 L (2.7/2.3 US/Imp qt) of oil. Use an API classification of SF or SG oil with SAE 10W-40 viscosity.

🔧 Oil drain plug: 23 N·m (2.3 kgf-m, 16.5 lb-ft)

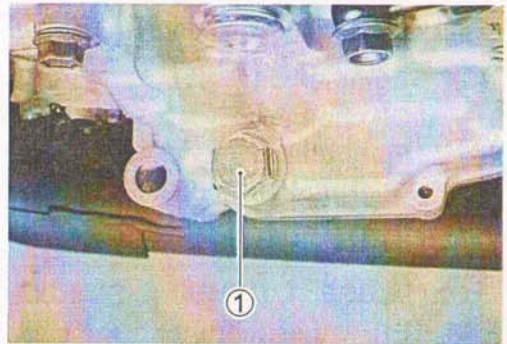

- Start the engine and allow it to run for three minutes at idling speed.
- Turn off the engine and wait about three minutes, then check the oil level through the inspection window **A**. If the level is below mark "L", add oil to "F" level. If the level is above mark "F", drain oil to "F" level.



OIL FILTER REPLACEMENT

- Drain engine oil in the same manner of engine oil replacement procedure.
- Remove the oil filter **1** by using the oil filter wrench. (Special tool)
- Apply engine oil lightly to the gasket of the new filter before installation.
- Install the new filter turning it by hand until you feel that the filter gasket contacts the mounting surface. Then tighten it 2 turns using the oil filter wrench.

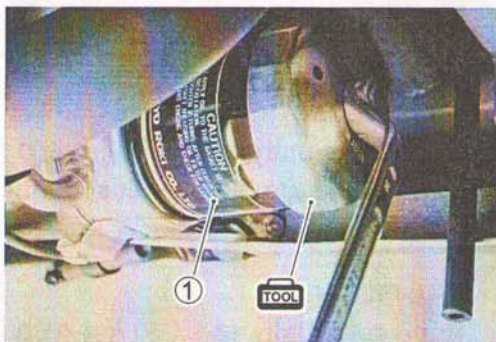

TOOL 09915-40610: Oil filter wrench

NOTE:

To properly tighten the filter, use the special tool. Never tighten the filter by hand.

- Pour fresh engine oil and check the oil level in the same manner of engine oil replacement procedure.

DATA Engine oil capacity

Oil change: 2.6 L (2.7/2.3 US/lmp qt)

Filter change: 2.9 L (3.1/2.6 US/lmp qt)

Overhaul engine: 3.4 L (3.6/3.0 US/lmp qt)

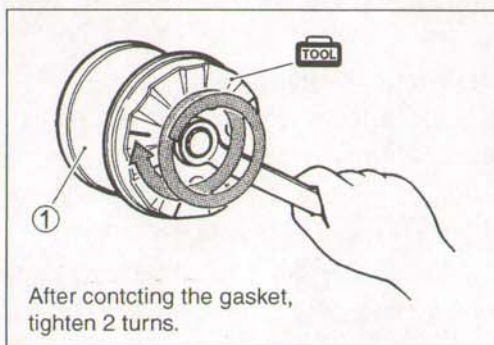

CAUTION

ONLY USE A GENUINE SUZUKI MOTORCYCLE OIL FILTER. Other manufacturer's oil filters may differ in thread specifications (thread diameter and pitch), filtering performance and durability which may lead to engine damage or oil leaks. Also, do not use a genuine Suzuki automobile oil filter on this motorcycle.

TRANSMISSION OIL

Replace initially at 1 000 km (600 miles, 1 month) and every 12 000 km (7 500 miles, 12 months) thereafter. Inspect every 6 000 km (4 000 miles, 6 months) thereafter.

TRANSMISSION OIL REPLACEMENT

- Keep the motorcycle upright with the center stand.
- Place an oil pan below the mission case.
- Remove the oil drain plug ① and filler plug ②.
- Tighten the drain plug ① to the specified torque, and pour fresh oil through the oil filler.
- Remove the oil level plug ③ and inspect the oil level. If the level is below the level hole, add oil until oil flows from the level hole.

Oil viscosity and classification

: SAE 10W-40 with API SF or SG

- Tighten the oil level plug ③ and filler plug ② to the specified torque.

 Transmission oil drain plug: 21 N·m (2.1 kgf·m, 15.0 lb-ft)

Transmission oil filler plug: 23 N·m (2.3 kgf·m, 16.5 lb-ft)

Transmission oil level plug: 21 N·m (2.1 kgf·m, 15.0 lb-ft)

DATA NECESSARY AMOUNT OF TRANSMISSION OIL

Oil change: 360 ml (12.2/12.7 US/Imp oz)

Overhaul: 400 ml (13.5/14.1 US/Imp oz)

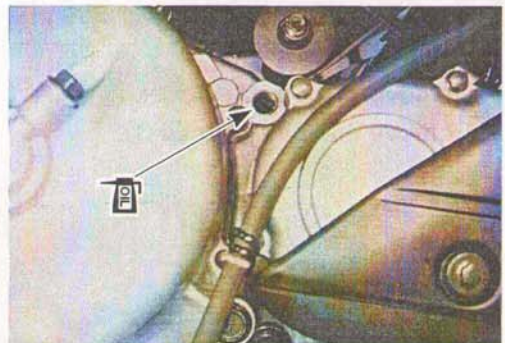
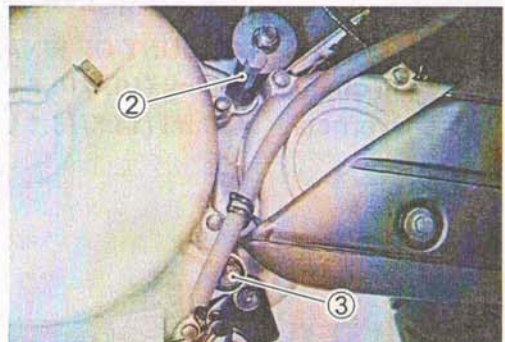
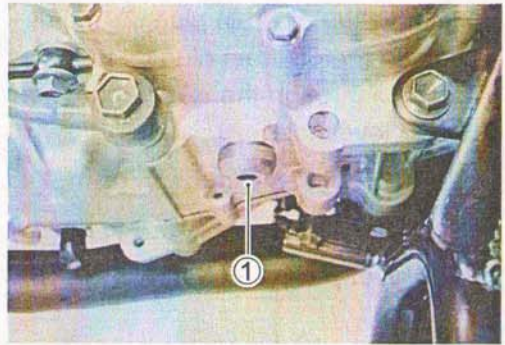

FINAL GEAR OIL

Replace initially at 1 000 km (600 miles, 1 month) and every 12 000 km (7 500 miles, 12 months) thereafter.

FINAL GEAR OIL REPLACEMENT

- Keep the motorcycle upright with the center stand.
- Remove the final gear case cover ①.
- Place an oil pan below the final gear case.

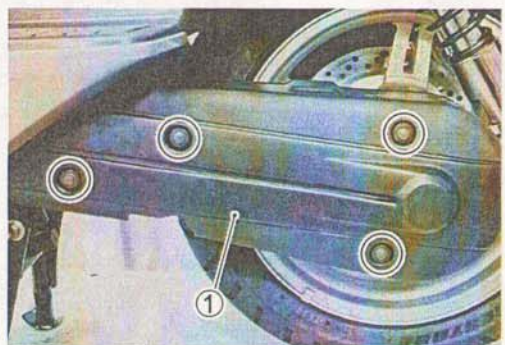



- Remove the oil drain plug ② and oil level plug ③.
- Tighten the oil drain plug ② to the specified torque, and pour fresh oil through the oil level hole until the oil over flows from the oil level hole.

 **Drain plug: 33 N·m (3.3 kgf-m, 24.0 lb-ft)**

- Tighten the oil level plug ③ to the specified torque.

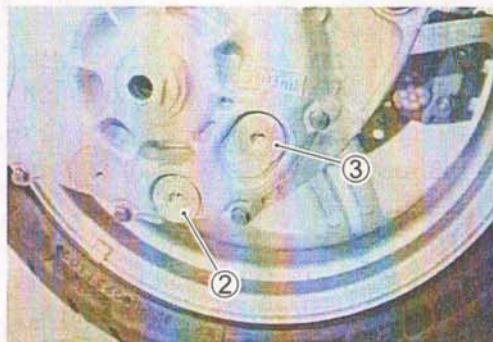
 **Oil level plug: 33 N·m (3.3 kgf-m, 24.0 lb-ft)**



 **Oil viscosity and classification**

: Hypoid gear oil SAE #90 API grade GL-5

DATA NECESSARY AMOUNT OF FINAL GEAR OIL

Oil change: 300 ml (10.1/10.6 US/lmp oz)

Overhaul: 430 ml (14.5/15.1 US/lmp oz)

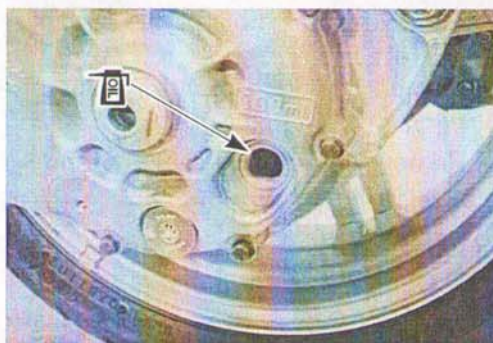

CVT FILTER

Inspect every 12 000 km (7 500 miles, 12 months).

- Remove the leg side cover. (☞ 9-12)
- Remove the CVT filter lid ①.

☆: hooked part

- Remove the CVT filter cover ②.

- Remove the CVT filter ③.

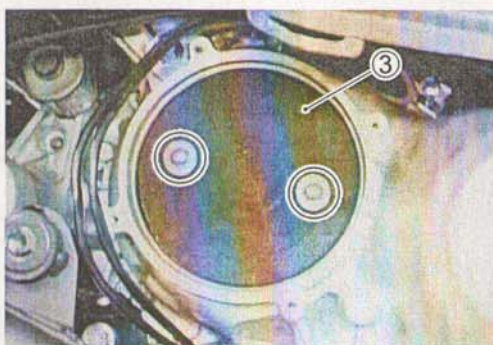
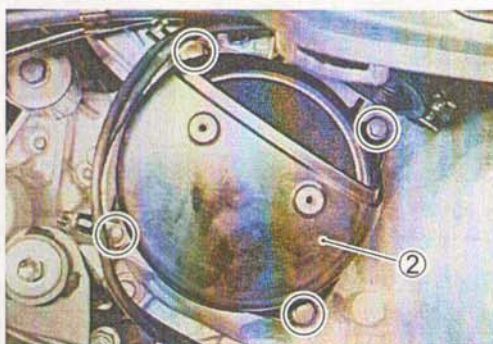
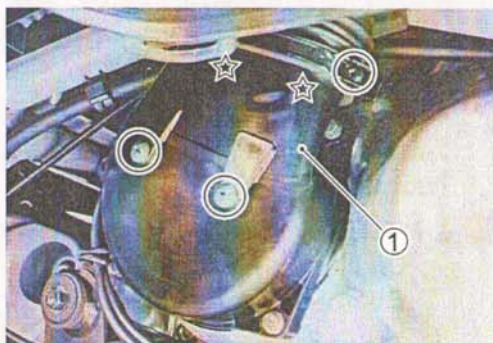

- Inspect the CVT filter for damage and dirt. If any defects are found, the CVT filter must be replaced.

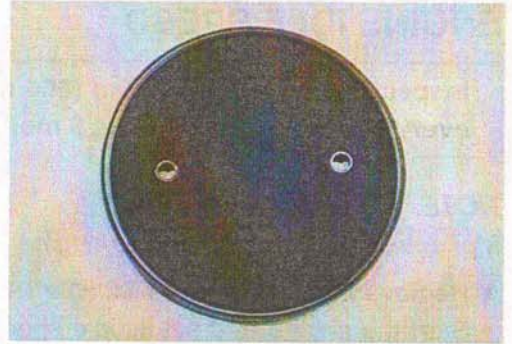

ENGINE IDLE SPEED

Inspect initially at 1 000 km (600 miles, 1 month) and every 6 000 km (4 000 miles, 6 months) thereafter.

NOTE:

Make this adjustment when the engine is hot.

- Remove the maintenance lid. (☞ 9-13)
- Start the engine and set its idle speed to the specified range by turning the throttle stop screw (A).

DATA Engine idle speed: 1 200 ± 100 r/min

THROTTLE CABLE PLAY

Inspect initially at 1 000 km (600 miles, 1 month) and every 6 000 km (4 000 miles, 6 months) thereafter.

Adjust the throttle cable play (A) with the following three steps.

MINOR ADJUSTMENT

First step:

- Loosen the locknut (3) of the throttle returning cable (1) and turn in the adjuster (4) fully into the threads.

Second step:

- Loosen the locknut (5) of the throttle pulling cable (2).
- Turn the adjuster (6) in or out until the throttle cable play (A) should be 2.0 – 4.0 mm (0.08 – 0.16 in) at the throttle grip.
- Tighten the locknut (5) while holding the adjuster (6).

Third step:

- While holding the throttle grip at the fully closed position, slowly turn out the adjuster (4) of the throttle returning cable (1) to feel resistance.
- Tighten the locknut (3) while holding the adjuster (4).

DATA Throttle cable play (A): 2.0 – 4.0 mm (0.08 – 0.16 in)

⚠ WARNING

After the adjustment is completed, check that handlebar movement does not raise the engine idle speed and that the throttle grip returns smoothly and automatically.

NOTE:

Major adjustment can be made by the throttle body side adjuster.

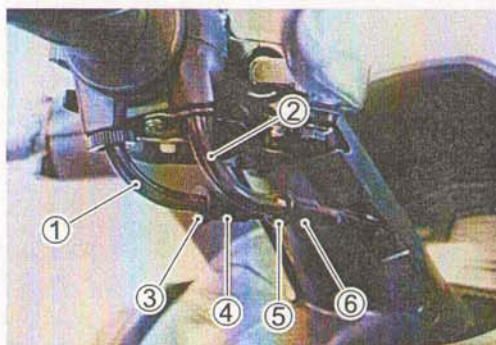
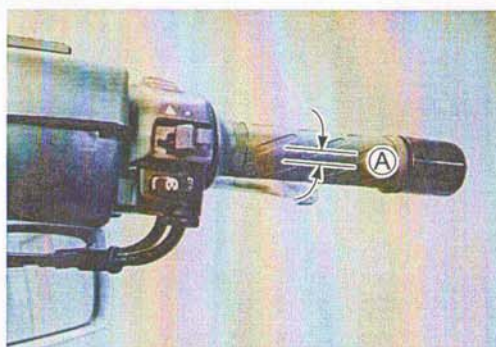

MAJOR ADJUSTMENT

- Remove the front box. (☞ 9-18)
- Loosen the locknut ① of the throttle returning cable ②.
- Turn the returning cable adjuster ③ to obtain proper cable play.
- Loosen the locknut ④ of the throttle pulling cable ⑤.
- Turn the pulling cable adjuster ⑥ in or out until the throttle cable play ① should be 2.0 – 4.0 mm (0.08 – 0.16 in) at the throttle grip.
- Tighten the locknut ④ securely while holding the adjuster ⑥.

DATA Throttle cable play ①: 2.0 – 4.0 mm (0.08 – 0.16 in)

- While holding the throttle grip at the fully closed position, slowly turn the returning cable adjuster ③ to obtain a slack ② of 1.0 mm (0.04 in).
- Tighten the locknut ① securely.

⚠ WARNING

After the adjustment is completed, check that handle-bar movement does not raise the engine idle speed and that the throttle grip returns smoothly and automatically.

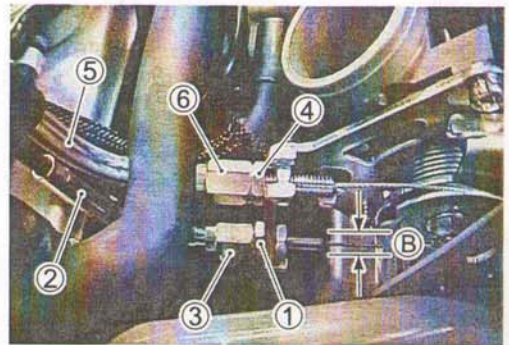
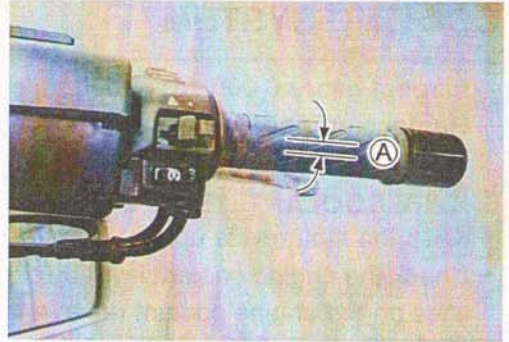
**THROTTLE VALVE SYNCHRONIZATION**

Inspect initially at 1 000 km (600 miles, 1 month) (E-33 only) and every 12 000 km (7 500 miles, 12 months).

Inspect the throttle valve synchronization periodically.
(☞ 7-24)

PAIR (AIR SUPPLY) SYSTEM

Inspect every 12 000 km (7 500 miles, 12 months).

Inspect the PAIR (air supply) system periodically.
(☞ 12-6)

EVAPORATIVE EMISSION CONTROL SYSTEM

Inspect every 12 000 km (7 500 miles, 12 months).
Replace vapor hose every 4 years.

Inspect the EVAP system periodically.
(☞ 12-9)

COOLING SYSTEM

Inspect every 6 000 km (4 000 miles, 6 months).
Replace engine coolant every 2 years.

ENGINE COOLANT LEVEL CHECK

- Keep the motorcycle upright with the center stand.
- Check the engine coolant level by observing the full and lower lines on the engine coolant reserve tank.

Ⓐ Full line Ⓑ Lower line

- If the level is below the lower line, add engine coolant to the full line from the engine coolant reserve tank filler. To remove the filler cap, remove the maintenance lid. (☞ 9-13)

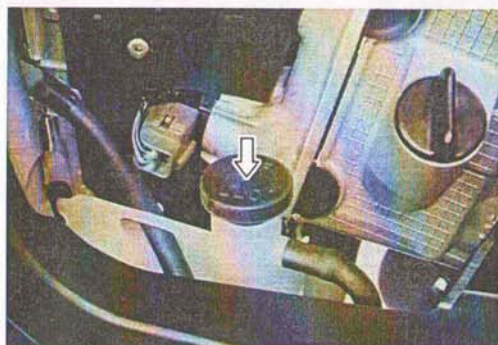
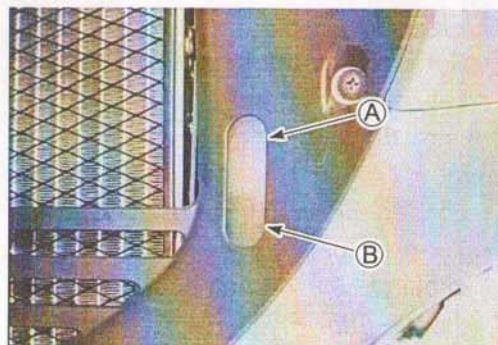

ENGINE COOLANT CHANGE

- Remove the lower leg shield. (☞ 9-10)
- Remove the radiator cap ①.
- Drain engine coolant by removing the drain bolt Ⓐ.

⚠ WARNING

- * Do not open the radiator cap when the engine is hot, as you may be injured by escaping hot liquid or vapor.
- * Engine coolant may be harmful if swallowed or if it comes in contact with skin or eyes. If engine coolant gets into the eyes or in contact with the skin, flush thoroughly with plenty of water. If swallowed, induce vomiting and call physician immediately!

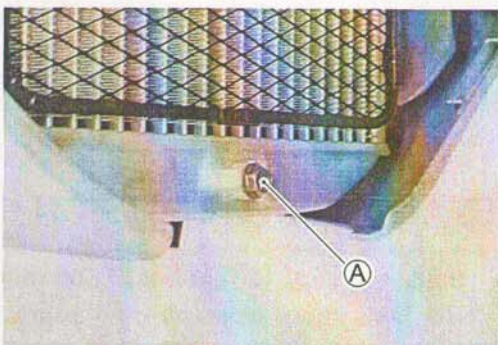
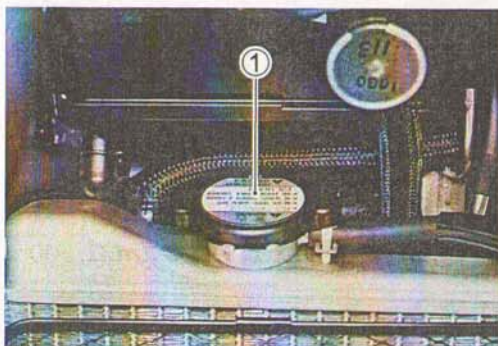

- Remove the front box. (☞ 9-18)
- Remove the foot board. (☞ 9-18)
- Drain engine coolant by disconnecting the radiator hose ②.
- Flush the radiator with fresh water if necessary.
- Tighten the water drain bolt ① to the specified torque.

🔧 Water drain bolt ①: 6 N·m (0.6 kgf·m, 4.3 lb·ft)

- Pour the specified engine coolant up to the radiator inlet.
- Bleed the air from the engine coolant circuit as following procedure.

NOTE:

For engine coolant information, refer to page 8-3.



AIR BLEEDING THE ENGINE COOLANT CIRCUIT

- Add engine coolant up to the radiator inlet.
- Support the motorcycle upright with the center stand.
- Slowly swing the motorcycle, right and left, to bleed the air trapped.
- Add engine coolant up to the radiator inlet.
- Start the engine and bleed air from the radiator inlet completely.
- Add engine coolant up to the radiator inlet.
- Repeat the above procedure until bleed no air from the radiator inlet.



- Close the radiator cap ① securely.
- After warming up and cooling down the engine several times, add the engine coolant up to the full level of the reserve tank.

CAUTION

Repeat the above procedure several times and make sure that the radiator is filled with engine coolant up to the reserve tank full level.

🔧 Engine coolant capacity

- Reverse tank side: 250 ml (0.3/0.2 US/Imp qt)
- Engine side: 1 050 ml (1.1/0.9 US/Imp qt)



RADIATOR HOSES

Check to see the radiator hoses for crack, damage or engine coolant leakage.

If any defects are found, replace the radiator hoses with new ones.

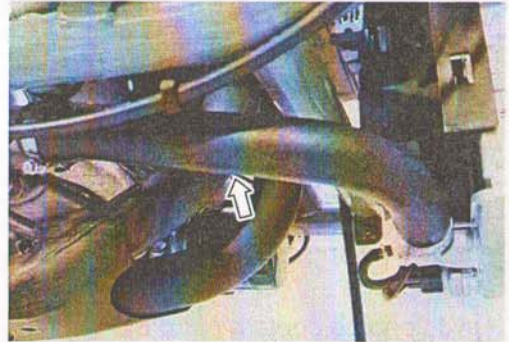
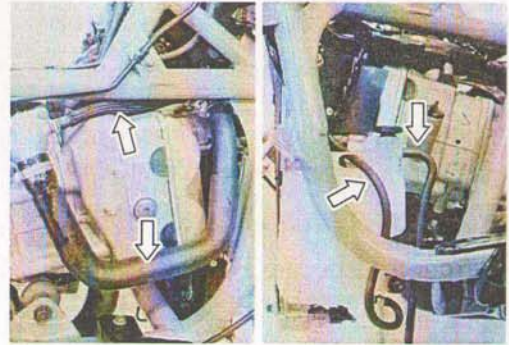

BRAKE

(BRAKE)

Inspect initially at 1 000 km (600 miles, 1 month) and every 6 000 km (4 000 miles, 6 months) thereafter.

(BRAKE HOSE AND BRAKE FLUID)

Inspect every 6 000 km (4 000 miles, 6 months). Replace hoses every 4 years. Replace fluid every 2 years.

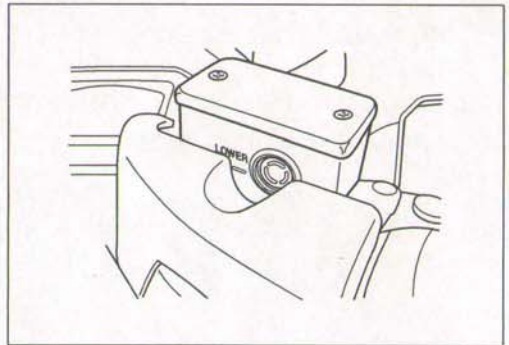

BRAKE FLUID LEVEL CHECK

- Keep the motorcycle upright and place the handlebars straight.
- Check the brake fluid level by observing the lower limit lines on the front and rear brake fluid reservoirs.
- When the level is below the lower limit line, replenish with brake fluid that meets the following specification.

 **Specification and Classification: DOT 4**

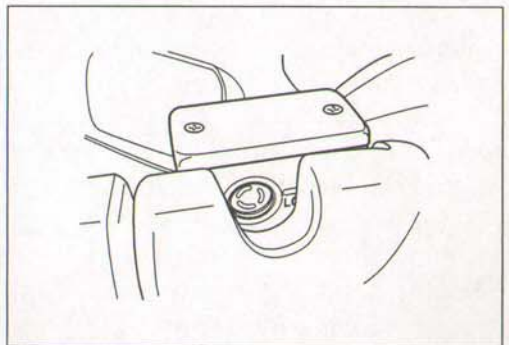

⚠ WARNING

The brake system of this motorcycle is filled with a glycol-based brake fluid. Do not use or mix different types of fluid such as silicone-based or petroleum-based. Do not use any brake fluid taken from old, used or unsealed containers. Never re-use brake fluid left over from the last servicing or stored for a long period.

⚠ WARNING

Brake fluid, if it leaks, will interfere with safe running and immediately discolor painted surfaces. Check the brake hoses and hose joints for cracks and fluid leakage before riding.

BRAKE PADS

The extent of brake pad wear can be checked by observing the grooved limit **(A)** on the pad. When the wear exceeds the grooved limit, replace the pads with new ones. (👉 9-64, 9-74)

CAUTION

Replace the brake pad as a set, otherwise braking performance will be adversely affected.

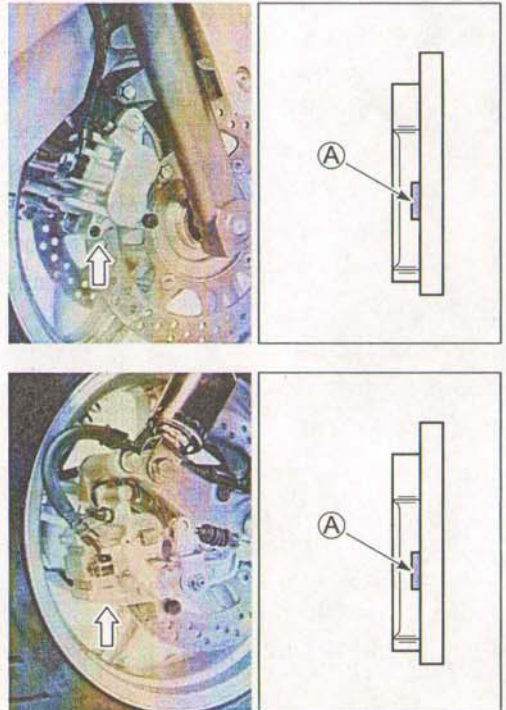

AIR BLEEDING THE BRAKE FLUID CIRCUIT

Air trapped in the fluid circuit acts like a cushion to absorb a large proportion of the pressure developed by the master cylinder and thus interferes with the full braking performance of the brake caliper. The presence of air is indicated by “sponginess” of the brake lever and also by lack of braking force. Considering the danger to which such trapped air exposes the machine and rider, it is essential that, after remounting the brake and restoring the brake system to the normal condition, the brake fluid circuit be purged of air in the following manner:

- Fill up the master cylinder reservoir to the “UPPER” line. Place the reservoir cap to prevent entry of dirt.
- Attach a pipe to the air bleeder valve, and insert the free end of the pipe into a receptacle.

 **Air bleeder valve: 7.5 N·m (0.75 kgf·m, 5.5 lb·ft)**

- Front brake: Bleed the air from the air bleeder valve.
- Squeeze and release the brake lever several times in rapid succession and squeeze the lever fully without releasing it. Loosen the bleeder valve by turning it a quarter of a turn so that the brake fluid runs into the receptacle; this will remove the tension of the brake lever causing it to touch the handlebar grip. Then, close the valve, pump and squeeze the lever, and open the valve. Repeat this process until the fluid flowing into the receptacle no longer contains air bubbles.

NOTE:

Replenish the brake fluid in the reservoir as necessary while bleeding the brake system. Make sure that there is always some fluid visible in the reservoir.

- Close the bleeder valve, and disconnect the pipe. Fill the reservoir with brake fluid to the “UPPER” line.

CAUTION

Handle brake fluid with care: the fluid reacts chemically with paint, plastics, rubber materials and so on.

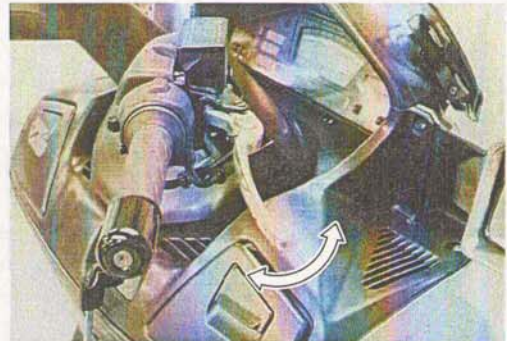
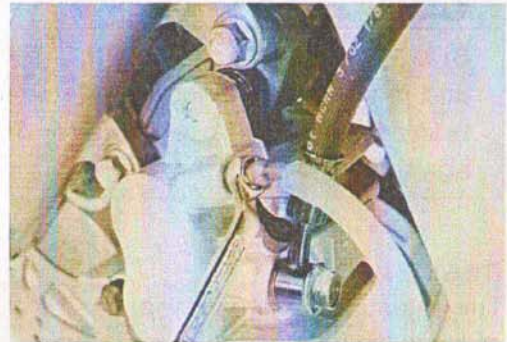

- The procedure to bleed the rear brake is identical to that of the front.

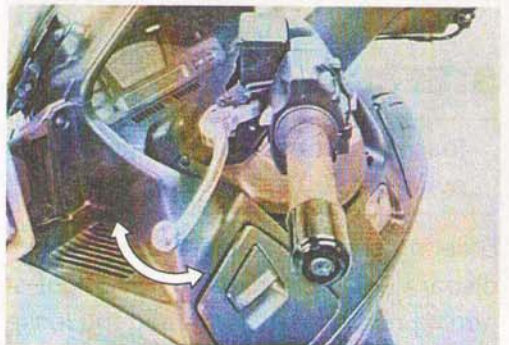
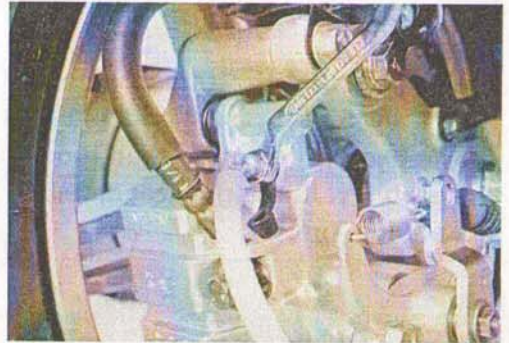
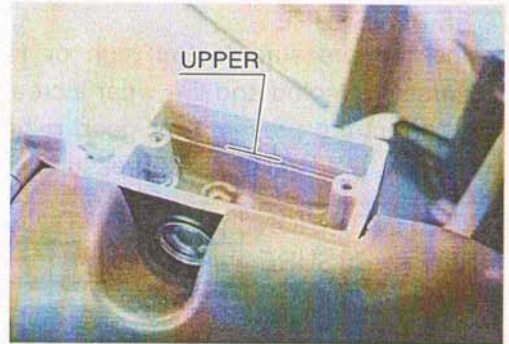

TIRE

Inspect every 6 000 km (4 000 miles, 6 months).

TIRE TREAD CONDITION

Operating the motorcycle with excessively worn tires will decrease riding stability and consequently invite a dangerous situation. It is highly recommended to replace a tire when the remaining depth of tire tread reaches the following specification.

TOOL 09900-20805: Tire depth gauge

DATA Tire tread depth

Service Limit (FRONT): 1.6 mm (0.06 in)
(REAR): 2.0 mm (0.08 in)

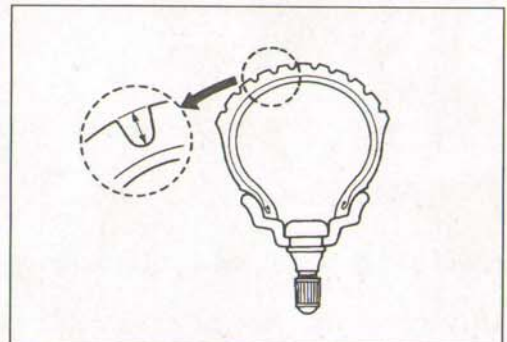

TIRE PRESSURE

If the tire pressure is too high or too low, steering will be adversely affected and tire wear increased. Therefore, maintain the correct tire pressure for good roadability or shorter tire life will result. Cold inflation tire pressure is as follows.

COLD INFLATION TIRE PRESSURE	SOLO RIDING			DUAL RIDING		
	kPa	kgf/cm ²	psi	kPa	kgf/cm ²	psi
FRONT	225	2.25	33	225	2.25	33
REAR	250	2.50	36	280	2.80	41

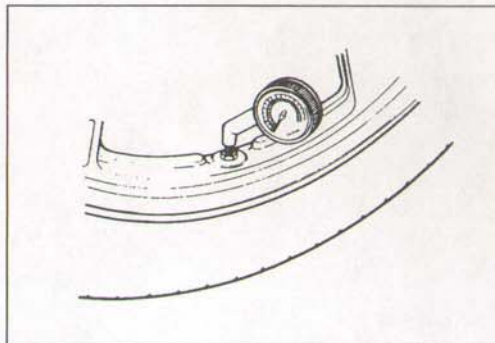

CAUTION

The standard tire fitted on this motorcycle is 120/70 R15M/C 56H for front and 160/60 R14M/C 65H for rear. The use of tires other than those specified may cause instability. It is highly recommended to use a SUZUKI Genuine Tire.

TIRE TYPE

BRIDGESTONE (Front: TH01F Rear: TH01R)

STEERING

Inspect initially at 1 000 km (600 miles, 1 month) and every 12 000 km (7 500 miles, 12 months) thereafter.

Steering should be adjusted properly for smooth turning of handlebars and safe running. Overtight steering prevents smooth turning of the handlebars and too loose steering will cause poor stability. Check that there is no play in the steering stem while grasping the lower fork tubes by supporting the machine so that the front wheel is off the ground, with the wheel straight ahead, and pull forward. If play is found, perform steering bearing adjustment as described in page 9-46 of this manual.

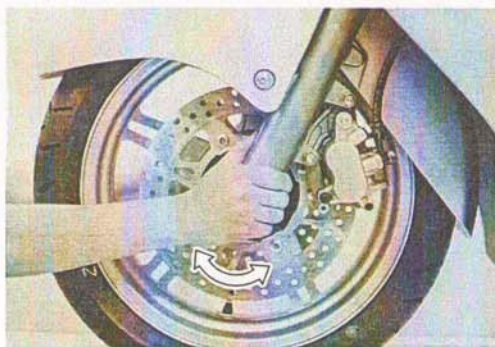

FRONT FORK

Inspect every 12 000 km (7 500 miles, 12 months).

Inspect the front forks for oil leakage, scoring or scratches on the outer surface of the inner tubes. Replace any defective parts, if necessary. (☞ 9-32)



REAR SUSPENSION

Inspect every 12 000 km (7 500 miles, 12 months).

Inspect the rear shock absorbers for oil leakage and mounting rubbers for wear and damage. Replace any defective parts, if necessary. (☞ 9-57)

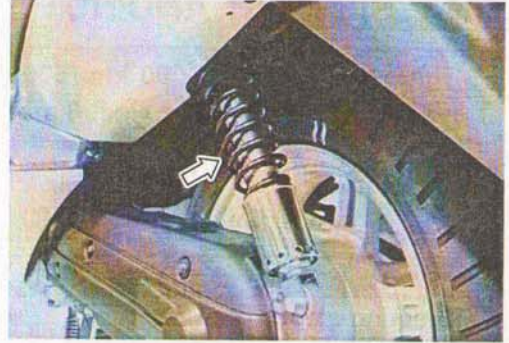

EXHAUST PIPE BOLT AND MUFFLER MOUNTING BOLT

Tighten initially at 1 000 km (600 miles, 1 month) and every 12 000 km (7 500 miles, 12 months) thereafter.

- Tighten the exhaust pipe bolts, muffler mounting bolts and nut to the specified torque.

☛ Muffler mounting bolt /nut (A): 23 N·m (2.3 kgf·m, 16.5 lb-ft)
Exhaust pipe bolt (B): 23 N·m (2.3 kgf·m, 16.5 lb-ft)

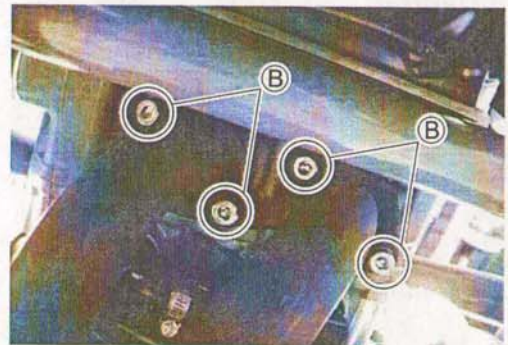
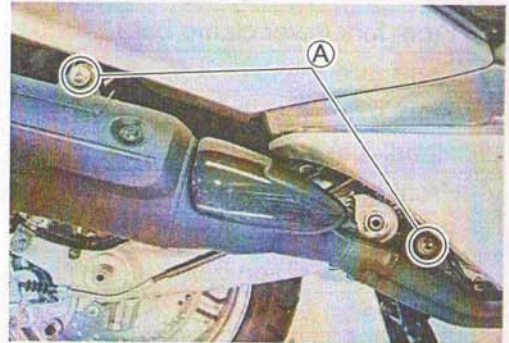

CHASSIS BOLT AND NUT

Tighten initially at 1 000 km (600 miles, 1 month) and every 6 000 km (4 000 miles, 6 months) thereafter.

Check that all chassis bolts and nuts are tightened to their specified torque. (Refer to page 2-28 for the locations of the following nuts and bolts on the motorcycle.)

ITEM		N-m	kgf-m	lb-ft
① Steering stem head nut		65	6.5	47.0
② Front fork upper clamp bolt		23	2.3	16.5
③ Front fork lower clamp bolt		23	2.3	16.5
④ Front axle		65	6.5	47.0
⑤ Front axle pinch bolt		23	2.3	16.5
⑥ Handlebar clamp bolt		23	2.3	16.5
⑦ Front brake master cylinder mounting bolt		10	1.0	7.0
⑧ Front brake caliper mounting bolt		26	2.6	19.0
⑨ Brake hose union bolt		23	2.3	16.5
⑩ Air bleeder valve		7.5	0.75	5.5
⑪ Brake disc bolt (Front & Rear)		23	2.3	16.5
⑫ Rear brake caliper mounting bolt		26	2.6	19.0
⑬ Rear brake master cylinder mounting bolt		10	1.0	7.0
⑭ Front footrest bracket mounting bolt	(M8)	26	2.6	19.0
	(M6)	11	1.1	8.0
⑮ Swingarm pivot nut		100	10.0	72.5
⑯ Rear shock absorber mounting nut (Upper & Lower)		29	2.9	21.0
⑰ Rear axle nut		100	10.0	72.5

