

Radial Lead Transient Voltage Suppressors (TVS)

KB Series 6KA

Description

The KB Series of high current transient suppressors have been specially designed for use in A.C. line protection and any demanding applications (AC or DC). Any voltage rise due to increased current conduction is contained to a minimum, providing the best possible protection level. They can also be connected in series and/or parallel to create very high capacity protection solutions.

Features

- u Axial lead terminals
- u High current transient suppressor
- u Excellent Clamping Capability
- u Glass Passivated Junction
- u Bi-directional
- u Low Slope Resistance
- u Repetition Rate (duty cycle):0.01%
- u Hazardous Substances Free
- u RoHS Compliant
- u High Temperature soldering: 260°C/10 seconds at terminals
- u Epoxy Encapsulated
- u Silver plated leads
- u Solderable per MIL-STD-202 Method 208

Bi-directional

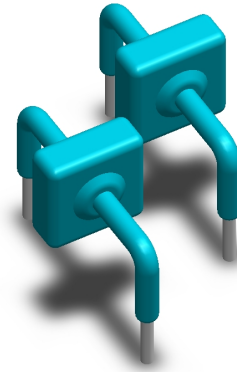

Functional Diagram

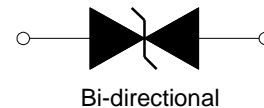

Maximum Ratings (T_A=25°C unless otherwise noted)

Parameter	Symbol	Value	Unit
Operating junction	T _J	-55 to +150	°C
Storage Temperature Range	T _{STG}	-55 to +150	°C
Current Rating ¹	I _{PP}	6	KA

Notes:

1. Rated IPP measured with 8 × 20μs pulse.

Electrical Characteristics (T_A=25°C unless otherwise noted)

Part Number	Reverse Stand-Off Voltage		Breakdown Voltage	Test Current	Current Rating	Maximum Clamping Voltage	Reverse Leakage
	V _{AC} (V)	V _{DC} (V)	V _{BR} (V) MIN. @I _T	I _T (mA)	I _{PP} 8/20μs (KA)	V _C (V) @I _{PP}	I _R (μA) @V _{DC}
KB-058	40	58	64	10	6	110	20
KB-076	54	76	83	10	6	135	20
KB-170	130	170	180	10	6	260	20
KB-190	145	190	200	10	6	290	20
KB-240	180	240	250	10	6	340	20
KB-380	275	380	401	10	6	520	20
KB-430	310	430	440	10	6	625	20

Radial Lead Transient Voltage Suppressors (TVS)

KB Series 6KA
Ratings and Characteristic Curves ($T_A=25^\circ\text{C}$ unless otherwise noted) (Continued)

Physical Specifications

Weight	Contact manufacturer
Case	Epoxy encapsulated
Terminal	Silver plated leads, solderable per MIL-STD-750, Method 2026

Soldering Parameters

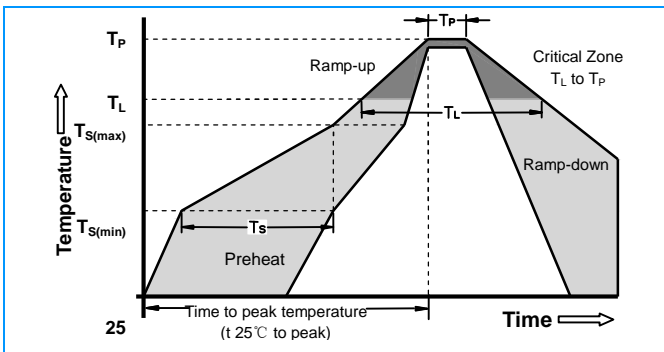

Reflow Condition		Lead-free assembly
Pre Heat	- Temperature Min ($T_{s(min)}$)	150°C
	- Temperature Max ($T_{s(max)}$)	200°C
	- Time (min to max) (t_s)	60 - 180 Seconds
Average ramp up rate (Liquidus Temp T_L) to peak		$3^\circ\text{C/second max}$
$T_{s(max)}$ to T_L - Ramp-up Rate		$3^\circ\text{C/second max}$
Reflow	- Temperature (T_L) (Liquidus)	217°C
	- Time (min to max) (t_s)	60 - 150 Seconds
Peak Temperature (T_P)		$260 \pm 0/-5^\circ\text{C}$
Time within 5°C of actual peak Temperature (t_p)		20 - 40 Seconds
Ramp-down Rate		$6^\circ\text{C/second max}$
Time 25°C to peak Temperature (T_P)		8 minutes Max
Do not exceed		280°C

Flow/Wave Soldering (Solder Dipping)

Peak Temperature :	265°C
Dipping Time :	10 seconds
Soldering :	1 time

Ratings and Characteristic Curves ($T_A=25^\circ\text{C}$ unless otherwise noted)

Pulse Derating Curve

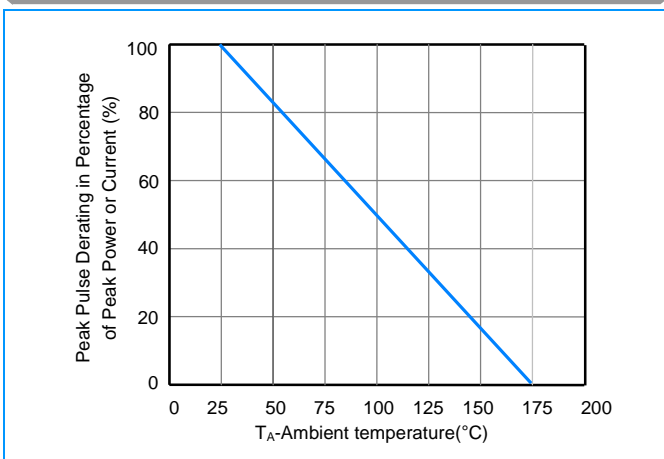

Radial Lead Transient Voltage Suppressors (TVS)

KB Series 6KA

Dimensions

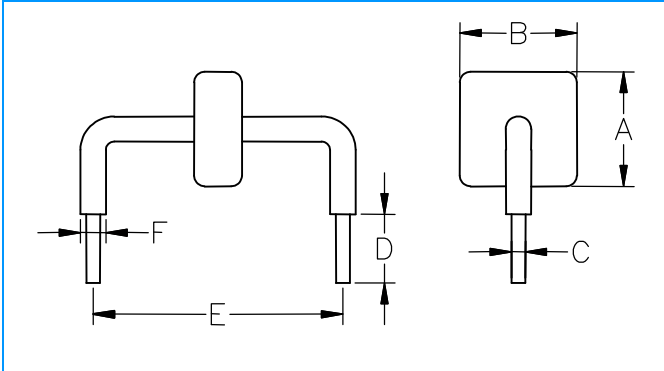

Dimensions	Inches	Millimeters
A	max 0.571	max 14.5
B	Max0.500	max 12.7
C	$\Phi 0.051 \pm 0.004$	$\Phi 1.30 \pm 0.1$
D	0.236 ± 0.040	6.0 ± 1.0
E	0.950 ± 0.028	24.15 ± 0.7
F	max 0.10	max 2.5

Part Numbering

