



FEATURES

- IGBT³ CHIP(Trench+Field Stop technology)
- Low saturation voltage and positive temperature coefficient
- Fast switching and short tail current
- Free wheeling diodes with fast and soft reverse recovery
- Temperature sense included

APPLICATIONS

- AC motor control
- Motion/servo control
- Photovoltaic/Fuel cell
- Inverter and power supplies



INVERTER SECTOR

ABSOLUTE MAXIMUM RATINGS

T_c=25°C unless otherwise specified

Symbol	Parameter	Test Conditions	Values	Unit
IGBT				
V _{CES}	Collector - Emitter Voltage	T _{vj} =25°C	1200	V
V _{GES}	Gate - Emitter Voltage		±20	V
I _c	DC Collector Current	T _c =25°C	500	A
		T _c =80°C	300	A
I _{CM}	Repetitive Peak Collector Current	t _p =1ms	600	A
P _{tot}	Power Dissipation Per IGBT		1400	W
Diode				
V _{RRM}	Repetitive Reverse Voltage	T _{vj} =25°C	1200	V
I _{F(AV)}	Average Forward Current	T _c =25°C	300	A
		T _c =80°C	180	A
I _{FRM}	Repetitive Peak Forward Current	t _p =1ms	600	A
I ² _t		T _{vj} =125°C, t=10ms, V _R =0V	17500	A ² s

INVERTER SECTOR

ELECTRICAL AND THERMAL CHARACTERISTICS

 $T_C=25^{\circ}\text{C}$ unless otherwise specified

Symbol	Parameter	Test Conditions	Min.	Typ.	Max.	Unit
IGBT						
$V_{GE(th)}$	Gate - Emitter Threshold Voltage	$V_{CE}=V_{GE}, I_C=12\text{mA}$	5.0	5.8	6.5	V
$V_{CE(sat)}$	Collector - Emitter Saturation Voltage	$I_C=300\text{A}, V_{GE}=15\text{V}, T_{Vj}=25^{\circ}\text{C}$		1.7		V
		$I_C=300\text{A}, V_{GE}=15\text{V}, T_{Vj}=125^{\circ}\text{C}$		2.0		V
I_{CES}	Collector Leakage Current	$V_{CE}=1200\text{V}, V_{GE}=0\text{V}, T_{Vj}=25^{\circ}\text{C}$			1	mA
		$V_{CE}=1200\text{V}, V_{GE}=0\text{V}, T_{Vj}=125^{\circ}\text{C}$			5	mA
I_{GES}	Gate Leakage Current	$V_{CE}=0\text{V}, V_{GE} \pm 15\text{V}, T_{Vj}=125^{\circ}\text{C}$	-400		400	nA
R_{Gint}	Integrated Gate Resistor			2.5		Ω
Q_{ge}	Gate Charge	$V_{CE}=600\text{V}, I_C=300\text{A}, V_{GE} = \pm 15\text{V}$		2.7		μC
C_{ies}	Input Capacitance	$V_{CE}=25\text{V}, V_{GE}=0\text{V}, f=1\text{MHz}$		21		nF
C_{res}	Reverse Transfer Capacitance				1.0	
$t_{d(on)}$	Turn - on Delay Time	$V_{CC}=600\text{V}, I_C=300\text{A}, T_{Vj}=25^{\circ}\text{C}$		160		ns
		$R_G = 2.4 \Omega, T_{Vj}=125^{\circ}\text{C}$		170		ns
t_r	Rise Time	$V_{GE} = \pm 15\text{V}, T_{Vj}=25^{\circ}\text{C}$		45		ns
		Inductive Load $T_{Vj}=125^{\circ}\text{C}$		50		ns
$t_{d(off)}$	Turn - off Delay Time	$V_{CC}=600\text{V}, I_C=300\text{A}, T_{Vj}=25^{\circ}\text{C}$		460		ns
		$R_G = 2.4 \Omega, T_{Vj}=125^{\circ}\text{C}$		530		ns
t_f	Fall Time	$V_{GE} = \pm 15\text{V}, T_{Vj}=25^{\circ}\text{C}$		100		ns
		Inductive Load $T_{Vj}=125^{\circ}\text{C}$		150		ns
E_{on}	Turn - on Energy	$V_{CC}=600\text{V}, I_C=300\text{A}, T_{Vj}=25^{\circ}\text{C}$		13		mJ
		$R_G = 2.4 \Omega, T_{Vj}=125^{\circ}\text{C}$		20		mJ
E_{off}	Turn - off Energy	$V_{GE} = \pm 15\text{V}, T_{Vj}=25^{\circ}\text{C}$		25		mJ
		Inductive Load $T_{Vj}=125^{\circ}\text{C}$		37		mJ
I_{sc}	Short Circuit Current	$t_{psc} \leq 10\mu\text{S}, V_{GE}=15\text{V}$ $T_{Vj}=125^{\circ}\text{C}, V_{CC}=900\text{V}$		1200		A
R_{thJC}	Junction-to-Case Thermal Resistance (Per IGBT)				0.09	K /W
Diode						
V_F	Forward Voltage	$I_F=300\text{A}, V_{GE}=0\text{V}, T_{Vj}=25^{\circ}\text{C}$		1.65		V
		$I_F=300\text{A}, V_{GE}=0\text{V}, T_{Vj}=125^{\circ}\text{C}$		1.6		V
t_{rr}	Reverse Recovery Time	$I_F=300\text{A}, V_R=600\text{V}$		225		ns
I_{RRM}	Max. Reverse Recovery Current	$di_F/dt=-4800\text{A}/\mu\text{s}$		255		A
E_{rec}	Reverse Recovery Energy	$T_{Vj}=125^{\circ}\text{C}$		24		mJ
R_{thJCD}	Junction-to-Case Thermal Resistance (Per Diode)				0.16	K /W

MIMMG300WB120B6TN

NTC CHARACTERISTIC VALUES

$T_c=25^\circ\text{C}$ unless otherwise specified

Symbol	Parameter	Test Conditions	Min.	Typ.	Max.	Unit
R_{25}	Resistance	$T_c=25^\circ\text{C}$		5		$\text{K}\Omega$
$B_{25/50}$				3375		K

MODULE CHARACTERISTICS

$T_c=25^\circ\text{C}$ unless otherwise specified

Symbol	Parameter	Test Conditions	Min.	Typ.	Max.	Unit
$T_{vj\ max}$	Max. Junction Temperature				150	$^\circ\text{C}$
$T_{vj\ op}$	Operating Temperature		-40		125	$^\circ\text{C}$
T_{stg}	Storage Temperature		-40		125	$^\circ\text{C}$
V_{isol}	Insulation Test Voltage	AC, $t=1\text{min}$		3000		V
CTI	Comparative Tracking Index		210			
Torque	Module-to-Sink	Recommended (M5)	2.5		5	N·m
Torque	Module Electrodes	Recommended (M6)	3		5	N·m
Weight				350		g

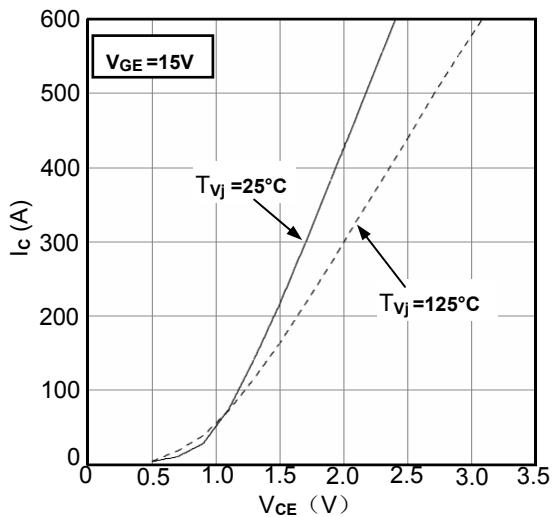

Figure1. Typical Output Characteristics IGBT-inverter

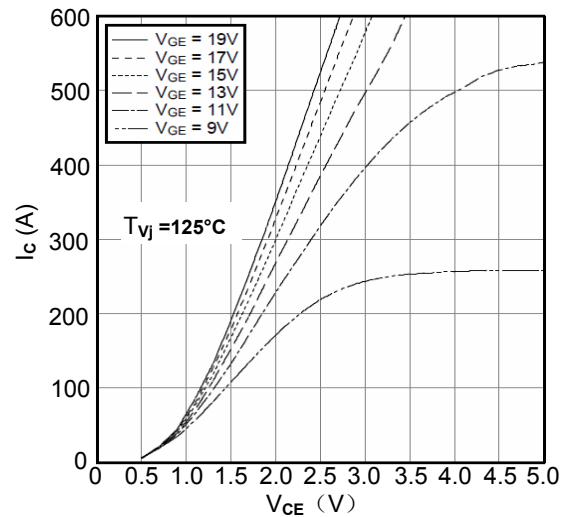

Figure2. Typical Output Characteristics IGBT-inverter

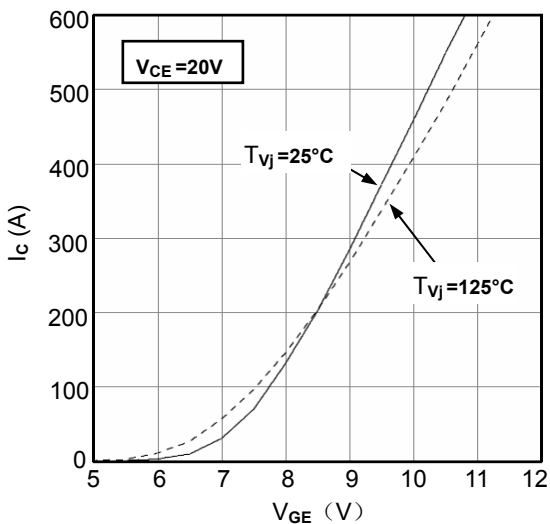

Figure3. Typical Transfer characteristics IGBT-inverter

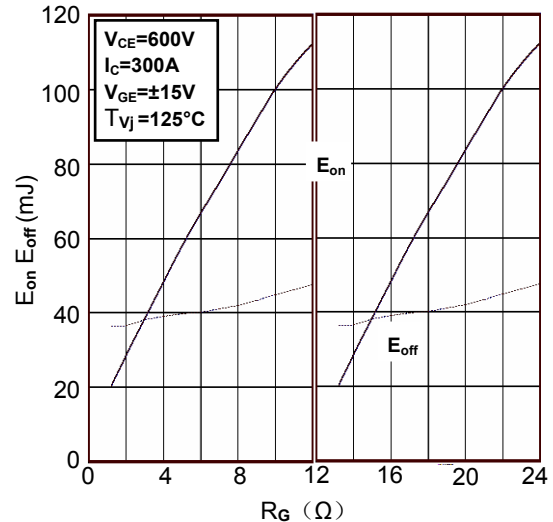

Figure4. Switching Energy vs. Gate Resistor IGBT-inverter

MIMMG300WB120B6TN

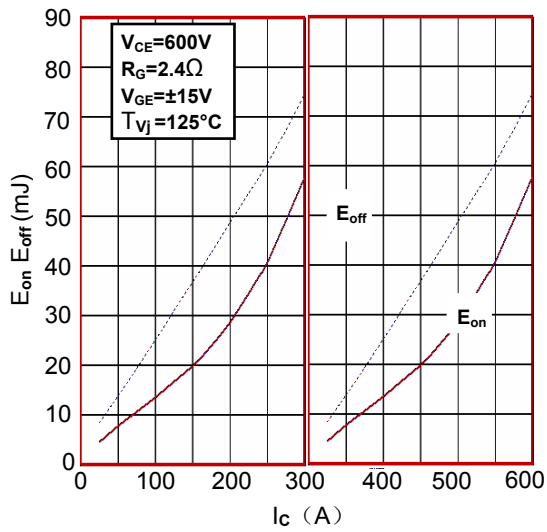

Figure 5. Switching Energy vs. Collector Current IGBT-inverter

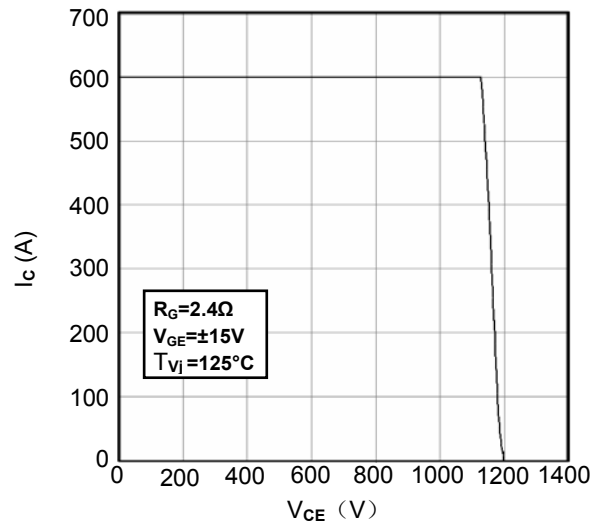

Figure 6. Reverse Biased Safe Operating Area IGBT-inverter

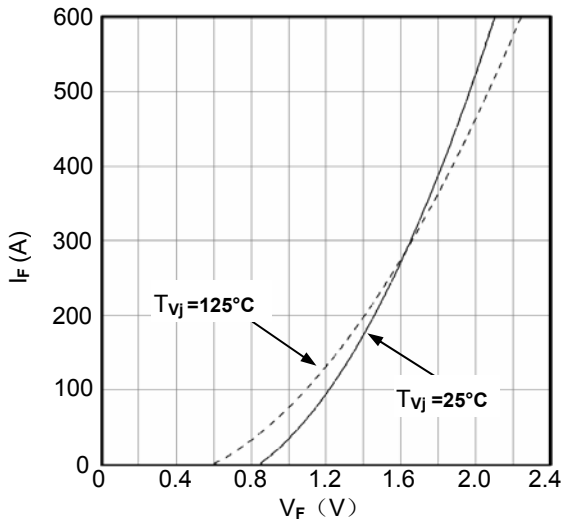

Figure 7. Diode Forward Characteristics Diode -inverter

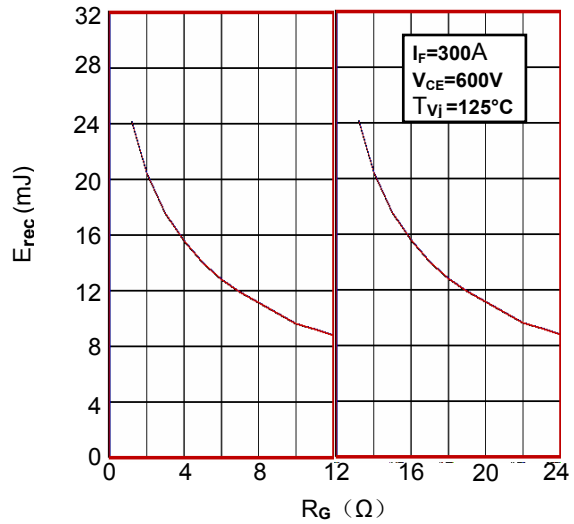

Figure 8. Switching Energy vs. Gate Resistor Diode -inverter

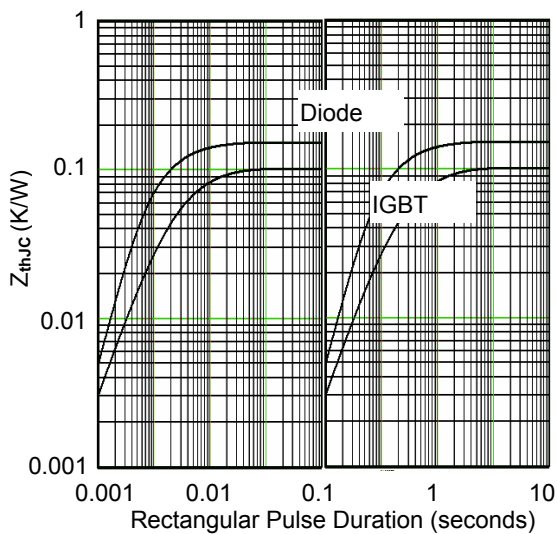

Figure 9. Transient Thermal Impedance of Diode and IGBT-inverter

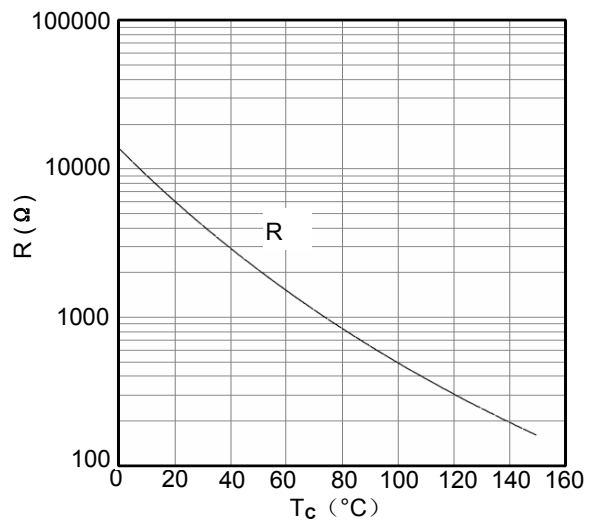

Figure 10. NTC Characteristics

MIMMG300WB120B6TN

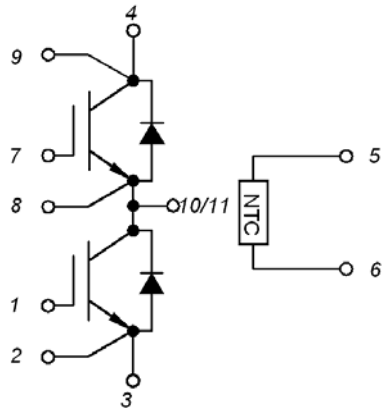
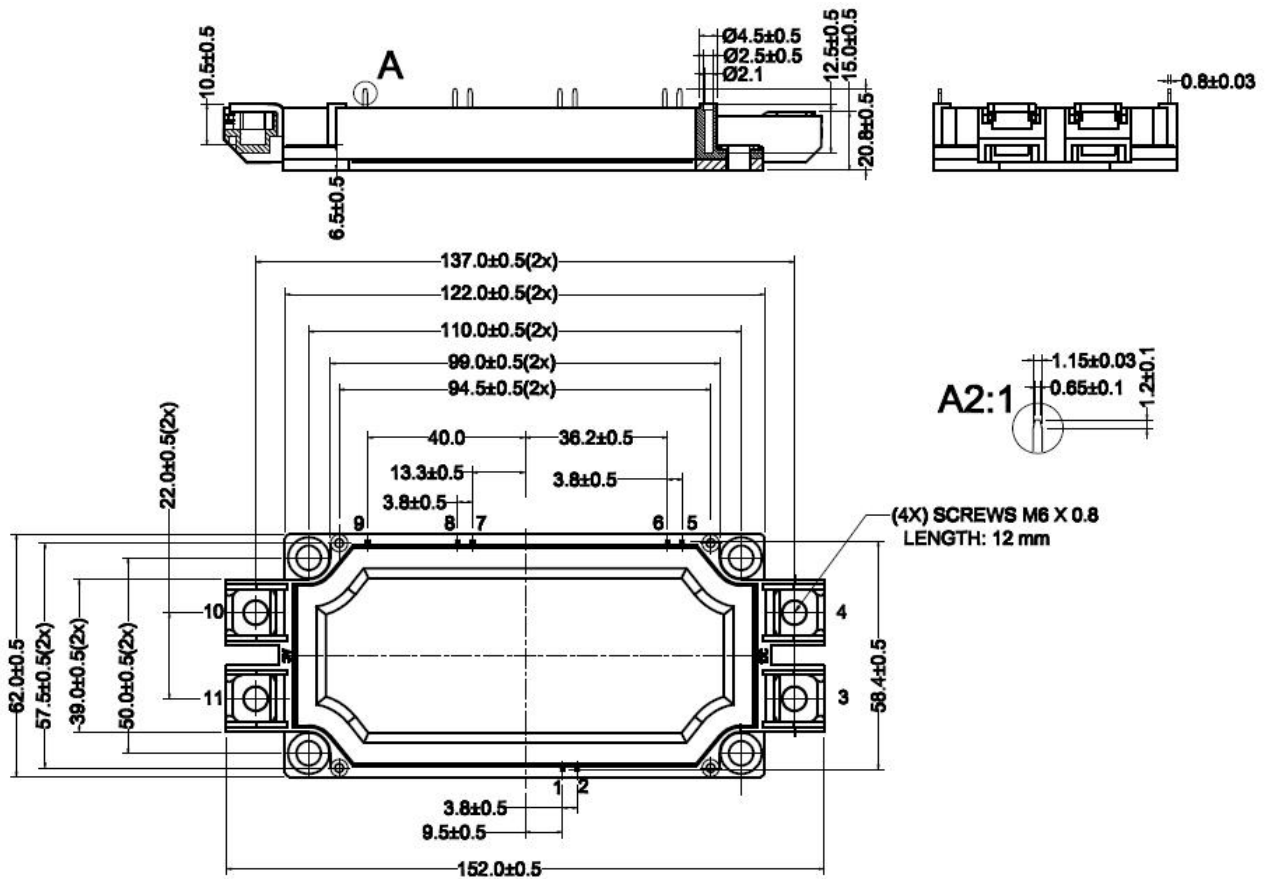

Figure11. Circuit Diagram



Dimensions (mm)
Figure12. Package Outline