

LD330 Series

Low Voltage Grade Brush Motors



Performance Features

- Low Voltage windings, 12, 24, 36 and 48 Vdc
- Continuous Torques from 7.5 to 14 lb-in
- High Peak Torque capability
- Speeds up to 6000 rpm
- 2 Pole Ceramic Magnet Structure
- Transaxle and NEMA 34 mounting
- Mounting for optional 24V Parking Brake
- High current Brush and Commutator Structure
- Smooth, Low Cogging design
- 18 inch heavy Duty cabled Motor Leads

Options

- NEMA 34 Flange Mount
- 24V, 35 lb-in Parking Brake w/ Mechanical Release
- Cable Power Fast-ons

Customer Defined Options

- Custom Shafts and Mounting
- Brake Coils, 12, 36, 48 Vdc
- Special Motor Winding (Ke)
- Special Connectors

Cont. Torque LD330 Series @ 36 Vdc

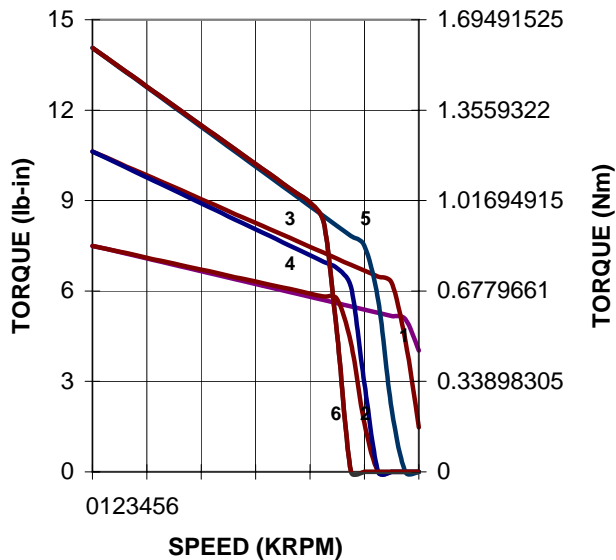

Peak Torque LD330 Series @ 36 Vdc

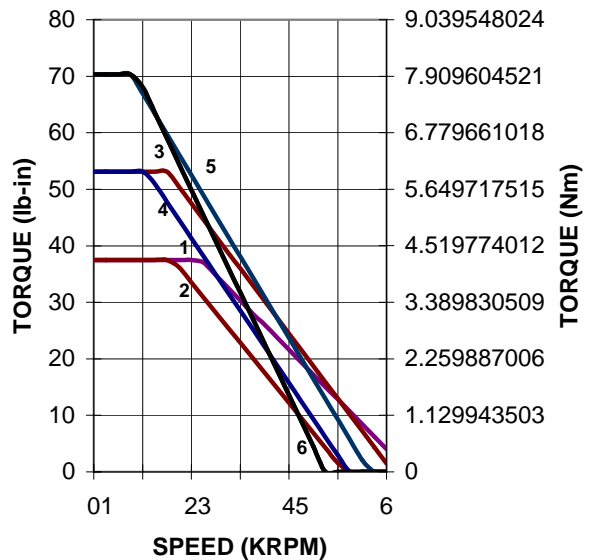

1 = LD332-F 2 = LD332-H 3 = LD333-D
 4 = LD333-E 5 = LD334-C 6 = LD334-D

DIMENSIONS

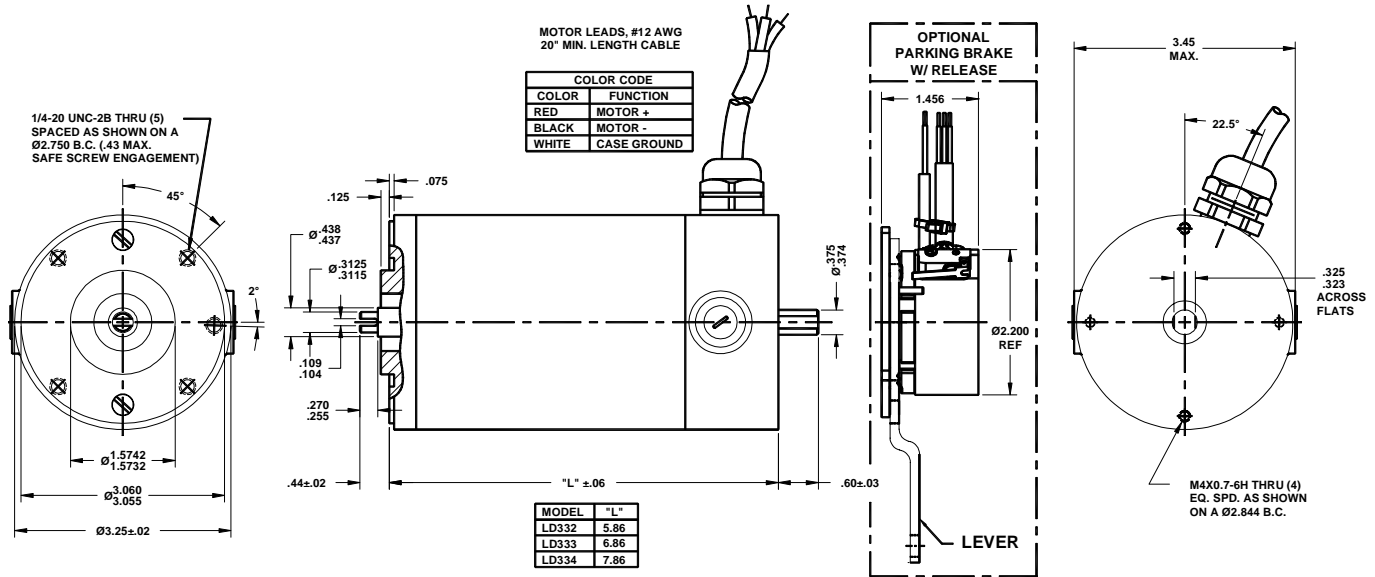

GENERAL	Condition	Units	LD332		LD333		LD334	
Continuous Stall Torque	1)	Nm / lb-in	0.85 / 7.5		1.2 / 10.6		1.59 / 14.1	
Peak Stall Torque	1)	Nm / lb-in	4.2 / 37.5		6 / 53.1		7.94 / 70.3	
WINDING			FH		D	E	CD	
Torque Constant	(+ / -10%)	Nm / A lb-in / A	0.053 0.465	0.066 0.583	0.055 0.490	0.065 0.575	0.060 0.532	0.072 0.634
Voltage Constant (back EMF)	(+ / -10%)	V / kRPM V / rad / s	5.50 0.053	6.90 0.066	5.80 0.055	6.80 0.065	6.30 0.060	7.50 0.072
Current at Cont. Stall Torque	1)	A	17.9	14.3	24.0	20.5	29.4	24.7
Current at Peak Torque		A	89.6	71.4	120.4	102.7	146.7	123.2
Terminal Resistance	(+ / -15%)	ohms	0.20	0.26	0.17	0.21	0.16	0.18
Inductance	(+ / -15%)	mH	0.33	0.52	0.23	0.32	0.19	0.28
Maximum Terminal Voltage (Vt)		V dc	48	48	48	48	48	48
Maximum Speed (no load)		RPM	6000	6000	6000	6000	6000	6000
Rated Speed @ 24 Vdc		RPM	3700	3000	3450	2900	3100	2600
Rated Speed @ 36 Vdc		RPM	5900	4700	5500	4650	4950	4200
MECHANICAL								
Armature Inertia		kg-cm ² lb-in-s ²	2.33 0.00206		3.39 0.0030		4.45 0.00394	
Thermal Resistance		°C/W	2.2		1.9		1.7	
Environmental Protection		IP	42		42		42	
Weight		Kg/lb	3.27 / 7.2		3.99 / 8.8		4.76 / 10.5	

1) 155°C winding temperature, all others at 25°C

HOW TO ORDER

L D 3 3 - **X T 3 B A**

Models

LD332
LD333
LD334

Winding Letter

Mounting Flange - Drive End

T3 - Transaxle Mount
N4 - NEMA 34 Flange and HD Shaft

Mounting Flange - Option End

B1 - Std. Brake Mount Surface w/o Brake
BA - w/ 24V Std Mech. Release Brake