

**PRELIMINARY DATA SHEET**

# SKY77550 Tx Quad-Band / Rx Dual-Band BiFET iPAC™ FEM for GSM / GPRS (824-915 MHz and 1710-1910 MHz)

**Applications**

- Dual-band cellular handsets encompassing
  - Class 4 GSM850/900
  - DCS1800/PCS1900
  - Class 12 GPRS multi-slot operation

**Features**

- High efficiency
  - 42% (GSM850)
  - 42% (GSM900)
  - 42% (DCS1800)
  - 41% (PCS1900)
- Low transmit supply current
  - 1.36 A (GSM850)
  - 1.36 A (GSM900)
  - 0.86 A (DCS1800)
  - 0.88 A (PCS1900)
- Internal ICC sense resistor for iPAC
- Closed loop iPAC
- 50 Ω matched Input/Output
- Tx–VCO-to-antenna and antenna-to-Rx-SAW filter RF interface
- RF switch affords high linearity, low insertion loss, and 0 V DC on Rx ports
- Small, low profile package
  - 6 mm x 6 mm x 0.9 mm
  - 28-pad configuration

**Description**

SKY77550 is a transmit and receive Front-End Module (FEM) with Integrated Power Amplifier Control (iPAC™) designed in a low profile, compact form factor for dual-band cellular handsets comprising GSM850/900 and DCS1800/PCS1900 operation. The SKY77550 offers a complete Transmit VCO-to-Antenna and Antenna-to-Receive SAW filter solution. The FEM also supports Class 12 General Packet Radio Service (GPRS) multi-slot operation.

The module consists of a GSM850/900 PA block and a DCS1800/PCS1900 PA block, impedance-matching circuitry for 50 ohm input and output impedances, Tx harmonics filtering, high linearity / low insertion loss RF switch, and a Power Amplifier Control (PAC) block with internal current sense resistor. The two Heterojunction Bipolar Transistor (HBT) PA blocks, a BiFET PAC and switch control circuit are fabricated onto a single Gallium Arsenide (GaAs) die. One PA block supports the GSM850/900 bands and the other PA block supports the DCS1800/PCS1900 bands. Both PA blocks share common power supply pads to distribute current. The output of each PA block and the outputs to the two receive pads are connected to the antenna pad through an RF switch. The GaAs die, Switch die and passive components are mounted on a multi-layer laminate substrate. The assembly is encapsulated with plastic overmold.

Band selection and control of transmit and receive are performed using four external control pads. Refer to the block diagram in Figure 1 below. The band select pad, BS, selects GSM850, GSM900, DCS, and PCS modes of operation. Transmit enable TxEN controls receive or transmit mode of the RF switch (Tx = logic 1). Proper timing between transmit enable TxEN and Analog Power Control VRAMP allows for high isolation between the antenna and Tx–VCO while the VCO is being tuned prior to the transmit burst.

The SKY77550 is compatible with logic levels from 1.2 V to 2.9 V for BS, TxEN, and VSW\_EN pads.

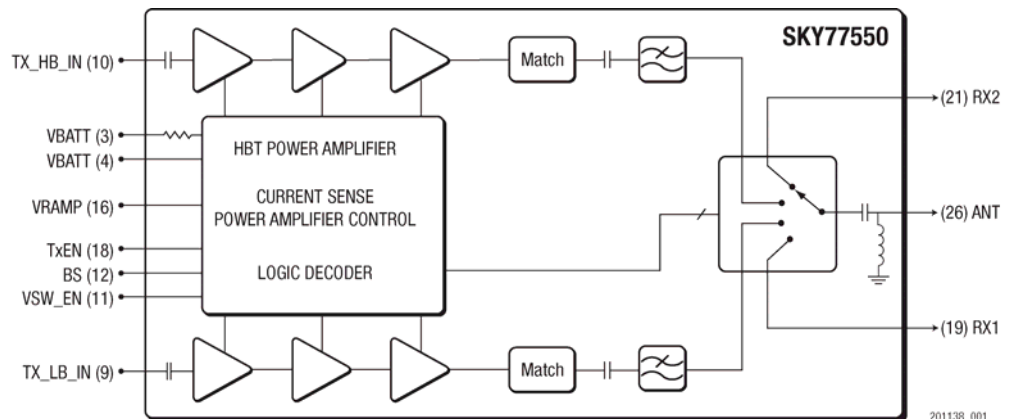

**Figure 1. SKY77550 Functional Block Diagram**

**NEW** Skyworks Green™ products are RoHS (Restriction of Hazardous Substances)-compliant, conform to the EIA/EICTA/JEITA Joint Industry Guide (JIG) Level A guidelines, are halogen free according to IEC-61249-2-21, and contain < 1,000 ppm antimony trioxide in polymeric materials.



**Electrical Specifications**

The following tables list the electrical characteristics of the SKY77550 Front-End Module. The absolute maximum ratings and recommended operating conditions for the SKY77550 are listed in Table 1 and Table 2, respectively. Table 3 specifies the mode control logic and Table 4 contains the electrical characteristics of

the SKY77550 for modes GSM850/900 and DCS1800/PCS1900. Figure 2 presents an application schematic for the SKY77550.

The SKY77550 is a static-sensitive electronic device and should not be stored or operated near strong electrostatic fields. Detailed information on device dimensions, pad descriptions, packaging and handling can be found in later sections of this data sheet.

**Table 1. SKY77550 Absolute Maximum Ratings**

Parameter	Minimum	Nominal	Maximum	Unit
Input Power (P <sub>IN</sub> )	—	3	15	dBm
Supply Voltage (V <sub>CC</sub> ), Standby V <sub>RAMP</sub> ≤ 0.3 V V <sub>SW_EN</sub> ≤ 0.5 V	—	3.5	7	V
Control Voltage (V <sub>RAMP</sub> )	-0.5	1.6	V <sub>CC_MAX</sub> - 0.2 V (See Table 4)	V
Storage Temperature	-55	+25	+150	°C

<sup>1</sup> No damage assuming only one parameter is set at limit with all other parameters set at nominal value.

**Table 2. SKY77550 Recommended Operating Conditions**

Parameter	Minimum	Nominal	Maximum	Unit
Supply Voltage (V <sub>CC</sub> )	3.1	3.5	4.8	V
Supply Current (I <sub>CC</sub> )	0	—	1.8	A
Operating Case Temperature (T <sub>CASE</sub> ) <sup>1</sup>	1-Slot (12.5% duty cycle)	-20	+85	°C
	2-Slot (25% duty cycle)	-20	+85	
	3-Slot (37.5% duty cycle) <sup>2</sup>	-20	+85	
	4-Slot (50% duty cycle) <sup>2</sup>	-20	+85	

<sup>1</sup> Case Operating Temperature refers to the temperature of the GROUND PAD on the underside of the package.

<sup>2</sup> Max. output power must be reduced by 6 dB to support 3-slot and 4-slot operation.

**Table 3. SKY77550 Mode Control Logic**

Mode	Input Control Bits		
	VSW_EN	TxEN	BS
STANDBY	0	0	0
Rx1 <sup>1</sup>	1	0	0
Rx2 <sup>1</sup>	1	0	1
Tx_LB	1	1	0
Tx_HB	1	1	1

<sup>1</sup> Rx1 and Rx2 are broadband receive ports and each supports the GSM850, GSM900, DCS, and PCS bands.

**Table 4. SKY77550 Electrical Specifications<sup>1</sup>**

<i>General</i>							
Parameter	Symbol	Test Condition	Minimum	Typical	Maximum	Unit	
Supply Voltage	V <sub>CC</sub>	—	3.1	3.5	4.8	V	
Power Control Impedance	Z <sub>VRAMP</sub>	—	—	120	—	kΩ	
VSW_EN Control Voltage	LOW	V <sub>SW_EN_LOW</sub>	—	—	0.3	V	
	HIGH	V <sub>SW_EN_HIGH</sub>					1.2
VSW_EN Current	I <sub>VSW_EN</sub>	—	—	—	25	μA	
Band Select Control Voltage	LOW	V <sub>BS_LOW</sub>	—	—	0.3	V	
	HIGH	V <sub>BS_HIGH</sub>					1.2
Band Select Current	I <sub>BS</sub>	—	—	—	25	μA	
TxEN Control Voltage	LOW	V <sub>TxEN_LOW</sub>	—	—	0.3	V	
	HIGH	V <sub>TxEN_HIGH</sub>					1.2
TxEN Control Current	I <sub>TxEN</sub>	—	—	—	60	μA	
Leakage Current	Standby Mode	I <sub>qs</sub>	3.1 V ≤ V <sub>CC</sub> ≤ 4.2 V V <sub>SW_EN</sub> = V <sub>SW_EN_LOW</sub> V <sub>RAMP</sub> ≤ 0.1 V TxEN ≤ TxEN <sub>LOW</sub> BS ≤ V <sub>BS_LOW</sub> MODE < V <sub>MODE_LOW</sub> T <sub>CASE</sub> = +25 °C PIN ≤ -60 dBm	—	30	50	μA
	Receive Mode	I <sub>qRx</sub>	V <sub>CC</sub> ≤ 4.2 V 1.8 V ≤ V <sub>SW_EN</sub> ≤ 2.5 V V <sub>RAMP</sub> ≤ 0.1 V TxEN ≤ TxEN <sub>LOW</sub> MODE < V <sub>MODE_LOW</sub> T <sub>CASE</sub> = +25 °C PIN ≤ -60 dBm	—	200	250	μA

<sup>1</sup> Unless specified otherwise:

T<sub>CASE</sub> = -20 °C to max. operating temperature (see Table 2); RL = 50 Ω; pulsed operation with pulse width ≤ 1154 μs and duty cycle ≤ 2:8; 3.1 V ≤ V<sub>CC</sub> ≤ 4.8 V.

**Table 5. SKY77550 Electrical Specifications<sup>1</sup>** (1 of 2)

<i>GSM850 (Tx_LB) Mode (f = 824 MHz to 849 MHz, -1 dBm ≤ P<sub>IN</sub> ≤ 5 dBm)</i>						
Parameter	Symbol	Test Condition	Minimum	Typical	Maximum	Unit
Frequency Range	<i>f</i>	—	824	—	849	MHz
Input Power	P <sub>IN</sub>	—	-1	—	5	dBm
Analog Power Control Voltage	V <sub>RAMP</sub>	—	0.2	—	1.6	V
Power Added Efficiency	PAE	V <sub>CC</sub> = 3.5 V P <sub>OUT</sub> = 33 dBm P <sub>IN</sub> = 3 dBm duty cycle 1:8 T <sub>CASE</sub> = +25 °C	39	42	—	%
Supply Current @ Rated Power	I <sub>CC_33 dBm</sub>	V <sub>CC</sub> = 3.5 V P <sub>OUT</sub> = 33 dBm P <sub>IN</sub> = 3 dBm duty cycle 1:8 T <sub>CASE</sub> = +25 °C	—	1.36	1.46	A
	I <sub>CC_29 dBm</sub>	V <sub>CC</sub> = 3.5 V P <sub>OUT</sub> = 29 dBm P <sub>IN</sub> = 3 dBm duty cycle 1:8 T <sub>CASE</sub> = +25 °C	—	770	—	mA
Supply Current @ Minimum Power	I <sub>CC_5 dBm</sub>	V <sub>CC</sub> = 3.5 V P <sub>OUT</sub> = 5 dBm P <sub>IN</sub> = 3 dBm duty cycle 1:8 T <sub>CASE</sub> = +25 °C	—	70	85	mA
Harmonics	2 <i>f</i> <sub>0</sub> to 13 <i>f</i> <sub>0</sub>	BW = 3 MHz 5 dBm ≤ P <sub>OUT</sub> ≤ 33 dBm V <sub>RAMP</sub> controlled <sup>2</sup>	—	-40	-33	dBm
Mismatch Harmonics	2 <i>f</i> <sub>0</sub> to 7 <i>f</i> <sub>0</sub>	BW = 3 MHz V <sub>RAMP</sub> = Max V <sub>RAMP</sub> <sup>4</sup> V <sub>BATT</sub> = 3.5 V VSWR = 3:1 all phases T <sub>CASE</sub> = +25 °C	—	—	-33	
Output Power	P <sub>OUT</sub>	V <sub>CC</sub> = 3.5 V T <sub>CASE</sub> = +25 °C P <sub>IN</sub> = -1 dBm	33.0	33.7	—	dBm
	P <sub>OUT_MAX LOW VOLTAGE</sub>	V <sub>CC</sub> = 3.1 V V <sub>RAMP</sub> = Max V <sub>RAMP</sub> <sup>4</sup> -20 °C ≤ T <sub>CASE</sub> ≤ +85 °C P <sub>IN</sub> = -1 dBm	30.5	32.0	—	
	P <sub>OUT_MAX HIGH VOLTAGE</sub>	V <sub>CC</sub> = 4.8 V V <sub>RAMP</sub> = Max V <sub>RAMP</sub> <sup>4</sup> -20 °C ≤ T <sub>CASE</sub> ≤ +85 °C P <sub>IN</sub> = -1 dBm	30.5	34.5	—	
Input VSWR	Γ <sub>IN</sub>	5 dBm ≤ P <sub>OUT</sub> ≤ 33 dBm V <sub>RAMP</sub> controlled <sup>2</sup>	—	1.5:1	2.5:1	
Forward Isolation <sup>3</sup>	P <sub>OUT_RX</sub>	P <sub>IN</sub> = 5 dBm V <sub>RAMP</sub> ≤ 0.1 V V <sub>SW_EN</sub> = V <sub>SW_EN_HIGH</sub> TxEN = V <sub>TXEN_LOW</sub> Rx1 Mode	—	-55	-45	dBm
	P <sub>OUT_ENABLED_TX</sub>	P <sub>IN</sub> = 5 dBm V <sub>RAMP</sub> ≤ 0.1 V V <sub>SW_EN</sub> = V <sub>SW_EN_HIGH</sub> TxEN = V <sub>TXEN_HIGH</sub>	—	-25	-5	

Table 5. SKY77550 Electrical Specifications<sup>1</sup> (2 of 2)

[continued] GSM850 (Tx_LB) Mode ( $f = 824 \text{ MHz to } 849 \text{ MHz, } -1 \text{ dBm} \leq P_{IN} \leq 5 \text{ dBm}$ )							
Parameter	Symbol	Test Condition	Minimum	Typical	Maximum	Unit	
Coupling of GSM850/900 Tx Output ( $f_0$ ) to Rx <sup>5</sup> Output pad <sup>4</sup>	CGHI_Tx-Rx_ $f_0$	5 dBm $\leq$ P <sub>OUT</sub> $\leq$ 33 dBm	—	-5	0	dBm	
Coupling of GSM850/900 Tx Output ( $2f_0, 3f_0$ ) to Rx <sup>5</sup> Output pad <sup>4</sup>	CGHI_Tx-DCS_Rx	5 dBm $\leq$ P <sub>OUT</sub> $\leq$ 33 dBm	—	-45	-36	dBm	
Spurious	Spur	All combinations of the following parameters: VRAMP = controlled <sup>2</sup> PIN = min. to max. 3.1 V $\leq$ V <sub>CC</sub> $\leq$ 4.8 V -20 °C $\leq$ T <sub>CASE</sub> $\leq$ +85 °C Load VSWR = 12:1, all phase angles	No parasitic oscillation > -35 dBm				
Load Mismatch	Load	All combinations of the following parameters: VRAMP = controlled <sup>2</sup> PIN = min. to max. 3.1 V $\leq$ V <sub>CC</sub> $\leq$ 4.8 V -20 °C $\leq$ T <sub>CASE</sub> $\leq$ +85 °C Load VSWR = 20:1, all phase angles	No module damage or permanent degradation				
Rx Band Spurious	RX_SPUR	At $f_0 + 20 \text{ MHz}$ (869 MHz to 894 MHz) RBW = 100 kHz V <sub>CC</sub> = 3.5 V T <sub>CASE</sub> = +25 °C 5 dBm $\leq$ P <sub>OUT</sub> $\leq$ 33 dBm	—	-84	-83	dBm	
		At 1930 MHz to 1990 MHz RBW = 100 kHz V <sub>CC</sub> = 3.5 V T <sub>CASE</sub> = +25 °C 5 dBm $\leq$ P <sub>OUT</sub> $\leq$ 33 dBm	—	-101	-84		
Power Control Dynamic Range	PCDR	—	30	50	—	dB	
Power Control Variation	Control Level 5	PCV	VBATT = 3.5 V P <sub>OUT</sub> = 33 dBm T <sub>CASE</sub> = +25 °C	-1.5	—	1.5	dB
			P <sub>OUT</sub> = 33 dBm	-2.0	—	2.0	
	Control Level 6-15	VBATT = 3.5 V 13 dBm $\leq$ P <sub>OUT</sub> $\leq$ 31 dBm T <sub>CASE</sub> = +25 °C	-2.5	—	2.5		
		13 dBm $\leq$ P <sub>OUT</sub> $\leq$ 31 dBm	-3.5	—	3.5		
	Control Level 16-19	VBATT = 3.5 V 5 dBm $\leq$ P <sub>OUT</sub> $\leq$ 11 dBm T <sub>CASE</sub> = +25 °C	-4.5	—	4.5		
		5 dBm $\leq$ P <sub>OUT</sub> $\leq$ 11 dBm	-5.5	—	5.5		
Power Control Slope	PCs	5 dBm to 33 dBm	—	—	250	dB/V	
GSM850 RECEIVE ( $f = 869 \text{ MHz to } 894 \text{ MHz}$ ) Rx Mode							
Parameter	Symbol	Test Condition	Minimum	Typical	Maximum	Units	
Frequency Range	$f$	—	869	—	894	MHz	
Insertion Loss, ANT to Rx <sup>5,3</sup>	IL_Rx <sup>5</sup>	T <sub>CASE</sub> = +25 °C	—	1.0	1.3	dB	
VSWR ANT, Rx <sup>5,3</sup>	$\Gamma_{IN}, \Gamma_{OUT}$	—	—	1.2:1	1.5:1		

<sup>1</sup> Unless specified otherwise:

T<sub>CASE</sub> = -20 °C to max. operating temperature (see Table 2); RL = 50  $\Omega$ ; pulsed operation with pulse width  $\leq$  1154  $\mu$ s and duty cycle  $\leq$  2:8; 3.1 V  $\leq$  V<sub>CC</sub>  $\leq$  4.8 V.

<sup>2</sup> VRAMP is calibrated to each PCL at T<sub>CASE</sub> = +25 °C, VBATT = 3.5 V, PIN = 3 dBm, 50  $\Omega$  load.

<sup>3</sup> Terminate all unused RF ports with 50  $\Omega$  loads

<sup>4</sup> Max VRAMP = VRAMP @ P<sub>OUT</sub> = 33 dBm, 50  $\Omega$  load, T<sub>CASE</sub> = +25 °C, VBATT = 3.5 V, PIN = 3 dBm

<sup>5</sup> Rx1 and Rx2 are broadband receive ports and each supports the GSM850, GSM900, DCS, and PCS bands.

**Table 6. SKY77550 Electrical Specifications<sup>1</sup>** (1 of 3)

<i>GSM900 (Tx_LB) Mode (f = 880 MHz to 915 MHz, -1 dBm ≤ P<sub>IN</sub> ≤ 5 dBm)</i>						
Parameter	Symbol	Test Condition	Minimum	Typical	Maximum	Units
Frequency Range	<i>f</i>	—	880	—	915	MHz
Input Power	P <sub>IN</sub>	—	-1	—	5	dBm
Analog Power Control Voltage	V <sub>RAMP</sub>	—	0.2	—	1.6	V
Power Added Efficiency	PAE	V <sub>CC</sub> = 3.5 V P <sub>OUT</sub> = 33 dBm P <sub>IN</sub> = 3 dBm duty cycle 1:8 T <sub>CASE</sub> = +25 °C	39	42	—	%
Supply Current @ Rated Power	I <sub>CC_33 dBm</sub>	V <sub>CC</sub> = 3.5 V P <sub>OUT</sub> = 33 dBm P <sub>IN</sub> = 3 dBm duty cycle 1:8 T <sub>CASE</sub> = +25 °C	—	1.36	1.46	A
	I <sub>CC_29 dBm</sub>	V <sub>CC</sub> = 3.5 V P <sub>OUT</sub> = 29 dBm P <sub>IN</sub> = 3 dBm duty cycle 1:8 T <sub>CASE</sub> = +25 °C	—	750	—	mA
Supply Current @ Minimum Power	I <sub>CC_5 dBm</sub>	V <sub>CC</sub> = 3.5 V P <sub>OUT</sub> = 5 dBm P <sub>IN</sub> = 3 dBm duty cycle 1:8 T <sub>CASE</sub> = +25 °C	—	70	85	mA
Harmonics	2 <i>f</i> <sub>0</sub> to 13 <i>f</i> <sub>0</sub>	BW = 3 MHz 5 dBm ≤ P <sub>OUT</sub> ≤ 33 dBm V <sub>RAMP</sub> controlled <sup>2</sup>	—	-40	-33	dBm
Mismatch Harmonics	2 <i>f</i> <sub>0</sub> to 7 <i>f</i> <sub>0</sub>	BW = 3 MHz V <sub>RAMP</sub> = Max V <sub>RAMP</sub> <sup>4</sup> V <sub>BATT</sub> = 3.5 V VSWR = 3:1 all phases T <sub>CASE</sub> = +25 °C	—	—	-33	dBm
Output Power	P <sub>OUT</sub>	V <sub>CC</sub> = 3.5 V T <sub>CASE</sub> = +25 °C P <sub>IN</sub> = -1 dBm	33.0	33.7	—	dBm
	P <sub>OUT_MAX LOW VOLTAGE</sub>	V <sub>CC</sub> = 3.1 V V <sub>RAMP</sub> = Max V <sub>RAMP</sub> <sup>4</sup> -20 °C ≤ T <sub>CASE</sub> ≤ +85 °C P <sub>IN</sub> = -1 dBm	30.5	32.0	—	
	P <sub>OUT_MAX HIGH VOLTAGE</sub>	V <sub>CC</sub> = 4.8 V V <sub>RAMP</sub> = Max V <sub>RAMP</sub> <sup>4</sup> -20 °C ≤ T <sub>CASE</sub> ≤ +85 °C P <sub>IN</sub> = -1 dBm	30.5	34.5	—	
Input VSWR	Γ <sub>IN</sub>	P <sub>OUT</sub> = 5 dBm to 33 dBm V <sub>RAMP</sub> controlled <sup>2</sup>	—	1.5:1	2.5:1	

Table 6. SKY77550 Electrical Specifications<sup>1</sup> (2 of 3)

[continued] GSM900 (Tx_LB) Mode ( $f = 880 \text{ MHz to } 915 \text{ MHz, } -1 \text{ dBm} \leq P_{IN} \leq 5 \text{ dBm}$ )						
Parameter	Symbol	Test Condition	Minimum	Typical	Maximum	Units
Forward Isolation <sup>3</sup>	POUT_Rx	PIN = 5 dBm VRAMP $\leq$ 0.1 V VSW_EN = VSW_EN_HIGH TxEN = VTXEN_LOW Rx1 Mode	—	-55	-45	dBm
	POUT_ENABLED_TX	PIN = 5 dBm VRAMP $\leq$ 0.1 V VSW_EN = VSW_EN_HIGH TxEN = VTXEN_HIGH	—	-25	-5	
Coupling of GSM850/900 Tx Output ( $f_0$ ) to Rx <sup>5</sup> Output pad <sup>3</sup>	CGHI_Tx-Rx_ $f_0$	5 dBm $\leq$ POUT $\leq$ 33 dBm	—	-5	0	dBm
Coupling of GSM850/900 Tx Output ( $2f_0, 3f_0$ ) to Rx <sup>5</sup> Output pad <sup>3</sup>	CGHI_Tx-Rx <sup>5</sup>	5 dBm $\leq$ POUT $\leq$ 33 dBm	—	-45	-36	dBm
Spurious	Spur	All combinations of the following parameters: VRAMP = controlled <sup>2</sup> PIN = min. to max. 3.1 V $\leq$ VCC $\leq$ 4.8 V -20 °C $\leq$ TCASE $\leq$ +85 °C Load VSWR = 12:1, all phase angles	No parasitic oscillation > -36 dBm			
Load Mismatch	Load	All combinations of the following parameters: VRAMP = controlled <sup>2</sup> PIN = min. to max. 3.1 V $\leq$ VCC $\leq$ 4.8 V -20 °C $\leq$ TCASE $\leq$ +85 °C Load VSWR = 20:1, all phase angles	No module damage or permanent degradation			
Rx Band Spurious	Rx_SPUR	At $f_0 + 20 \text{ MHz}$ (935 MHz to 960 MHz) RBW = 100 kHz VCC = 3.5 V TCASE = +25 °C 5 dBm $\leq$ POUT $\leq$ 33 dBm	—	-84	-83	dBm
		At $f_0 + 10 \text{ MHz}$ (925 MHz to 935 MHz) RBW = 100 kHz VCC = 3.5 V TCASE = +25 °C 5 dBm $\leq$ POUT $\leq$ 33 dBm	—	-80	-76	
		At 1805 MHz to 1880 MHz RBW = 100 kHz VCC = 3.5 V TCASE = +25 °C 5 dBm $\leq$ POUT $\leq$ 33 dBm	—	-101	-84	
Power Control Dynamic Range	PCDR	—	30	50	—	dB
Power Control Variation	PCV	VBATT = 3.5 V POUT = 33 dBm TCASE = +25 °C	-1.5	—	1.5	dB
		POUT = 33 dBm	-2.0	—	2.0	
		VBATT = 3.5 V 13 dBm $\leq$ POUT $\leq$ 31 dBm TCASE = +25 °C	-2.5	—	2.5	
		13 dBm $\leq$ POUT $\leq$ 31 dBm	-3.5	—	3.5	
		VBATT = 3.5 V 5 dBm $\leq$ POUT $\leq$ 11 dBm TCASE = +25 °C	-4.5	—	4.5	
5 dBm $\leq$ POUT $\leq$ 11 dBm	-5.5	—	5.5			
Power Control Slope	PCs	5 dBm to 33 dBm	—	—	250	dB/V

**Table 6. SKY77550 Electrical Specifications<sup>1</sup> (3 of 3)**

<i>GSM900 RECEIVE (f = 925 MHz to 960 MHz) Rx Mode</i>						
Parameter	Symbol	Test Condition	Minimum	Typical	Maximum	Units
Frequency Range	<i>f</i>	—	925	—	960	MHz
Insertion Loss, ANT to Rx <sup>5,3</sup>	IL_Rx <sup>5</sup>	TCASE = +25 °C	—	1.0	1.3	dB
VSWR ANT, Rx <sup>5,3</sup>	Γ <sub>IN</sub> , Γ <sub>OUT</sub>	—	—	1.2:1	1.5:1	

<sup>1</sup> Unless specified otherwise:  
TCASE = -20 °C to max. operating temperature (see Table 2); RL = 50 Ω; pulsed operation with pulse width ≤ 1154 μs and duty cycle ≤ 2:8; 3.1 V ≤ VCC ≤ 4.8 V.  
<sup>2</sup> VRAMP is calibrated to each PCL at TCASE = +25 °C, VBATT = 3.5 V, PIN = 3 dBm, 50 Ω load.  
<sup>3</sup> Terminate all unused RF ports with 50 Ω loads  
<sup>4</sup> Max VRAMP = VRAMP @ POUT = 33 dBm, 50 Ω load, TCASE +25 °C, VBATT = 3.5 V, PIN = 3 dBm  
<sup>5</sup> Rx1 and Rx2 are broadband receive ports and each supports the GSM850, GSM900, DCS, and PCS bands.

**Table 7. SKY77550 Electrical Specifications<sup>1</sup> (1 of 3)**

<i>DCS1800 (Tx_HB) Mode (f = 1710 MHz to 1785 MHz, -1 dBm ≤ PIN ≤ 5 dBm)</i>						
Parameter	Symbol	Test Condition	Minimum	Typical	Maximum	Units
Frequency Range	<i>f</i>	—	1710	—	1785	MHz
Input Power	PIN	—	-1	—	5	dBm
Analog Power Control Voltage	VRAMP	—	0.2	—	1.6	V
Power Added Efficiency	PAE	VCC = 3.5 V POUT = 31 dBm PIN = 3 dBm duty cycle 1:8 TCASE = +25 °C	37	42	—	%
Supply Current @ Rated Power	icc_31 dBm	VCC = 3.5 V POUT = 31 dBm PIN = 3 dBm duty cycle 1:8 TCASE = +25 °C	—	0.86	0.97	A
	icc_28 dBm	VCC = 3.5 V POUT = 28 dBm PIN = 3 dBm duty cycle 1:8 TCASE = +25 °C	—	630	—	mA
Supply Current @ Minimum Power	icc_0 dBm	VCC = 3.5 V POUT = 0 dBm PIN = 3 dBm duty cycle 1:8 TCASE = +25 °C	—	40	55	mA
Harmonics	2f <sub>0</sub> to 7f <sub>0</sub>	BW = 3 MHz, 0 dBm ≤ POUT ≤ 31 dBm VRAMP controlled <sup>2</sup>	—	-40	-33	dBm
Mismatch Harmonics	2f <sub>0</sub> , 3f <sub>0</sub>	BW = 3 MHz VRAMP = Max VRAMP <sup>4</sup> VBATT = 3.5 V VSWR = 3:1 all phases TCASE = +25 °C	—	—	-33	dBm



**Table 7. SKY77550 Electrical Specifications<sup>1</sup> (2 of 3)**

[continued] DCS1800 (Tx_HB) Mode ( $f = 1710 \text{ MHz to } 1785 \text{ MHz}$ , $-1 \text{ dBm} \leq P_{IN} \leq 5 \text{ dBm}$ )						
Parameter	Symbol	Test Condition	Minimum	Typical	Maximum	Units
Output Power	P <sub>OUT</sub>	V <sub>CC</sub> = 3.5 V T <sub>CASE</sub> = +25 °C P <sub>IN</sub> = -1 dBm	31.0	32.0	—	dBm
	P <sub>OUT_MAX LOW VOLTAGE</sub>	V <sub>CC</sub> = 3.1 V V <sub>RAMP</sub> = MAX V <sub>RAMP</sub> <sup>4</sup> -20 °C ≤ T <sub>CASE</sub> ≤ +85 °C P <sub>IN</sub> = -1 dBm	28.5	30.0	—	
	P <sub>OUT_MAX HIGH VOLTAGE</sub>	V <sub>CC</sub> = 4.8 V V <sub>RAMP</sub> = Max V <sub>RAMP</sub> <sup>4</sup> -20 °C ≤ T <sub>CASE</sub> ≤ +85 °C P <sub>IN</sub> = -1 dBm	28.5	32.5	—	
Input VSWR	Γ <sub>IN</sub>	0 dBm ≤ P <sub>OUT</sub> ≤ 31 dBm V <sub>RAMP</sub> controlled <sup>2</sup>	—	1.5:1	2.5:1	—
Forward Isolation <sup>3</sup>	P <sub>OUT Rx</sub>	P <sub>IN</sub> = 5 dBm V <sub>RAMP</sub> ≤ 0.1 V V <sub>SW_EN</sub> = V <sub>SW_EN_HIGH</sub> TxEN = V <sub>TxEN_LOW</sub> Rx2 Mode	—	-65	-53	dBm
	P <sub>OUT_ENABLED_TX</sub>	P <sub>IN</sub> = 5 dBm V <sub>RAMP</sub> ≤ 0.1 V V <sub>SW_EN</sub> = V <sub>SW_EN_HIGH</sub> TxEN = V <sub>TxEN_HIGH</sub>	—	-35	-5	
Coupling of DCS Tx output to Receive RF output pad <sup>3</sup>	CD <sub>CS_Tx-Rx_f0</sub>	0 dBm ≤ P <sub>OUT</sub> ≤ 31 dBm	—	0	5	dBm
Spurious	Spur	All combinations of the following parameters: V <sub>RAMP</sub> = controlled <sup>2</sup> P <sub>IN</sub> = min. to max. 3.1 V ≤ V <sub>CC</sub> ≤ 4.8 V -20 °C ≤ T <sub>CASE</sub> ≤ +85 °C Load VSWR = 12:1, all phase angles	No parasitic oscillation > -36 dBm			
Load Mismatch	Load	All combinations of the following parameters: V <sub>RAMP</sub> = controlled <sup>2</sup> P <sub>IN</sub> = min. to max. 3.1 V ≤ V <sub>CC</sub> ≤ 4.8 V -20 °C ≤ T <sub>CASE</sub> ≤ +85 °C Load VSWR = 20:1, all phase angles	No module damage or permanent degradation			
Rx Band Spurious	RX_SPUR	At f <sub>0</sub> + 20 MHz (1805 MHz to 1880 MHz) RBW = 100 kHz V <sub>CC</sub> = 3.5 V T <sub>CASE</sub> = +25 °C 0 dBm ≤ P <sub>OUT</sub> ≤ 31 dBm	—	-83	-78	dBm
		925 MHz to 960 MHz RBW = 100 kHz V <sub>CC</sub> = 3.5 V T <sub>CASE</sub> = +25 °C 0 dBm ≤ P <sub>OUT</sub> ≤ 31 dBm	—	—	-87	
Power Control Dynamic Range	PC <sub>DR</sub>	—	35	50	—	dB

**Table 7. SKY77550 Electrical Specifications<sup>1</sup>** (3 of 3)

[continued] DCS1800 (Tx_HB) Mode ( $f = 1710 \text{ MHz to } 1785 \text{ MHz, } -1 \text{ dBm} \leq P_{IN} \leq 5 \text{ dBm}$ )							
Parameter	Symbol	Test Condition	Minimum	Typical	Maximum	Units	
Power Control Variation	Control Level 0	PCv	VBATT = 3.5 V 30 dBm ≤ POUT ≤ 31 dBm TCASE = +25 °C	-1.5	—	1.5	dB
			30 dBm ≤ POUT ≤ 31 dBm	-2.0	—	2.0	
	Control Level 1-8	PCv	VBATT = 3.5 V 14 dBm ≤ POUT ≤ 28 dBm TCASE = +25 °C	-2.5	—	2.5	
			14 dBm ≤ POUT ≤ 28 dBm	-3.5	—	3.5	
	Control Level 9-13	PCv	VBATT = 3.5 V 4 dBm ≤ POUT ≤ 12 dBm TCASE = +25 °C	-3.5	—	3.5	
			4 dBm ≤ POUT ≤ 12 dBm	-4.5	—	4.5	
	Control Level 14-15	PCv	VBATT = 3.5 V 0 dBm ≤ POUT ≤ 2 dBm TCASE = +25 °C	-4.5	—	4.5	
0 dBm ≤ POUT ≤ 2 dBm			-5.5	—	5.5		
Power Control Slope	PCs	0 dBm to 31 dBm	—	—	250	dB/V	
DCS1800 RECEIVE ( $f = 1805 \text{ MHz to } 1880 \text{ MHz}$ ) Rx Mode							
Parameter	Symbol	Test Condition	Minimum	Typical	Maximum	Units	
Frequency Range	$f$	—	1805	—	1880	MHz	
Insertion Loss, ANT to Rx <sup>5,3</sup>	IL_Rx <sup>5</sup>	TCASE = +25 °C	—	1.2	1.5	dB	
VSWR ANT, Rx <sup>5,3</sup>	$\Gamma_{IN}, \Gamma_{OUT}$	—	—	1.2:1	1.5:1		

<sup>1</sup> Unless specified otherwise:  
TCASE = -20 °C to max. operating temperature (see Table 2); RL = 50 Ω; pulsed operation with pulse width ≤ 1154 μs and duty cycle ≤ 2:8; 3.1 V ≤ VCC ≤ 4.8 V.  
<sup>2</sup> VRAMP is calibrated to each PCL at TCASE = +25 °C, VBATT = 3.5 V, PIN = 3 dBm, 50 Ω load.  
<sup>3</sup> Terminate all unused RF ports with 50 Ω loads  
<sup>4</sup> Max VRAMP = VRAMP @ POUT = 31 dBm, 50 Ω load, TCASE +25 °C, VBATT = 3.5 V, PIN = 3 dBm  
<sup>5</sup> Rx1 and Rx2 are broadband receive ports and each supports the GSM850, GSM900, DCS, and PCS bands.

**Table 8. SKY77550 Electrical Specifications<sup>1</sup>** (1 of 3)

PCS1900 (Tx_HB) Mode ( $f = 1850 \text{ MHz to } 1910 \text{ MHz, } -1 \text{ dBm} \leq P_{IN} \leq 5 \text{ dBm}$ )						
Parameter	Symbol	Test Condition	Minimum	Typical	Maximum	Units
Frequency Range	$f$	—	1850	—	1910	MHz
Input Power	PIN	—	-1	—	5	dBm
Analog Power Control Voltage	VRAMP	—	0.2	—	1.6	V
Power Added Efficiency	PAE	VCC = 3.5 V POUT = 31 dBm PIN = 3 dBm duty cycle 1:8 TCASE = +25 °C	37	41	—	%

**Table 8. SKY77550 Electrical Specifications<sup>1</sup>** (2 of 3)

[continued] PCS1900 (Tx_HB) Mode ( $f = 1850 \text{ MHz to } 1910 \text{ MHz}$ , $-1 \text{ dBm} \leq P_{IN} \leq 5 \text{ dBm}$ )						
Parameter	Symbol	Test Condition	Minimum	Typical	Maximum	Units
Supply Current @ Rated Power	icc_31 dBm	VCC = 3.5 V PIN = 3 dBm POUT = 31 dBm duty cycle 1:8 TCASE = +25 °C	—	0.88	0.97	A
	icc_28 dBm	VCC = 3.5 V PIN = 3 dBm POUT = 28 dBm duty cycle 1:8 TCASE = +25 °C	—	630	—	mA
Supply Current @ Minimum Power	icc_0 dBm	VCC = 3.5 V PIN = 3 dBm POUT = 0 dBm duty cycle 1:8 TCASE = +25 °C	—	45	55	mA
Harmonics	2f <sub>0</sub> to 7f <sub>0</sub>	BW = 3 MHz, 0 dBm ≤ POUT ≤ 31 dBm VRAMP controlled <sup>2</sup>	—	-40	-33	dBm
Mismatch Harmonics	2f <sub>0</sub> , 3f <sub>0</sub>	BW = 3 MHz VRAMP = MAX VRAMP <sup>4</sup> VBATT = 3.5 V VSWR = 3:1 all phases TCASE = +25 °C	—	—	-33	dBm
Output Power	POUT	VCC = 3.5 V TCASE = +25 °C PIN = -1 dBm	31.0	32.0	—	dBm
	POUT_MAX LOW VOLTAGE	VCC = 3.1 V VRAMP = MAX VRAMP <sup>4</sup> -20 °C ≤ TCASE ≤ +85 °C PIN = -1 dBm	28.5	30.0	—	
	POUT_MAX HIGH VOLTAGE	VCC = 4.8 V VRAMP = MAX VRAMP <sup>4</sup> -20 °C ≤ TCASE ≤ +85 °C PIN = -1 dBm	28.5	32.5	—	
Input VSWR	Γ <sub>IN</sub>	0 dBm POUT ≤ 31 dBm VRAMP controlled <sup>2</sup>	—	1.5:1	2.5:1	—
Forward Isolation <sup>3</sup>	POUT <sub>Rx</sub>	PIN = 5 dBm VRAMP ≤ 0.1 V VSW_EN = VSW_EN_HIGH TxEN = VTxEN_LOW Rx2 Mode	—	-60	-53	dBm
	POUT_ENABLED_TX	PIN = 5 dBm VRAMP ≤ 0.1 V VSW_EN = VSW_EN_HIGH TxEN = VTxEN_HIGH	—	-35	-5	
Coupling of PCS Tx Output to Receive RF Output pad <sup>3</sup>	CPCS_Tx-Rx_f0	0 dBm ≤ POUT ≤ 31 dBm	—	0	5	dBm
Spurious	Spur	All combinations of the following parameters: VRAMP = controlled <sup>2</sup> PIN = min. to max 3.1 V ≤ VCC ≤ 4.8 V -20 °C ≤ TCASE ≤ +85 °C Load VSWR = 12:1, all phase angles	No parasitic oscillation > -36 dBm			

**Table 8. SKY77550 Electrical Specifications<sup>1</sup> (3 of 3)**

[continued] <i>PCS1900 (Tx_HB) Mode (f = 1850 MHz to 1910 MHz, -1 dBm ≤ P<sub>IN</sub> ≤ 5 dBm)</i>							
Parameter	Symbol	Test Condition	Minimum	Typical	Maximum	Units	
Load Mismatch	Load	All combinations of the following parameters: VRAMP = controlled <sup>2</sup> PIN = min. to max. 3.1 V ≤ VCC ≤ 4.8 V -20 °C ≤ TCASE ≤ +85 °C Load VSWR = 20:1, all phase angles	No module damage or permanent degradation				
Rx Band Spurious	Rx_SPUR	At f <sub>0</sub> + 20 MHz (1930 MHz to 1990 MHz) RBW = 100 kHz VCC = 3.5 V TCASE = +25 °C 0 dBm ≤ P <sub>OUT</sub> ≤ 31 dBm	—	-83	-78	dBm	
		869 MHz to 894 MHz RBW = 100 kHz VCC = 3.5 V TCASE = +25 °C 0 dBm ≤ P <sub>OUT</sub> ≤ 31 dBm	—	—	-87		
Power Control Dynamic Range	PCDR		35	50	—	dB	
Power Control Variation	Control Level 0	PCV VBATT = 3.5 V 30 dBm ≤ P <sub>OUT</sub> ≤ 31 dBm TCASE = +25 °C	30 dBm ≤ P <sub>OUT</sub> ≤ 31 dBm	-1.5	—	1.5	dB
			30 dBm ≤ P <sub>OUT</sub> ≤ 33 dBm	-2.0	—	2.0	
	Control Level 1-8	VBATT = 3.5 V 14 dBm ≤ P <sub>OUT</sub> ≤ 28 dBm TCASE = +25 °C	14 dBm ≤ P <sub>OUT</sub> ≤ 28 dBm	-2.5	—	2.5	
			14 dBm ≤ P <sub>OUT</sub> ≤ 28 dBm	-3.5	—	3.5	
	Control Level 9-13	VBATT = 3.5 V 4 dBm ≤ P <sub>OUT</sub> ≤ 12 dBm TCASE = +25 °C	4 dBm ≤ P <sub>OUT</sub> ≤ 12 dBm	-3.5	—	3.5	
			4 dBm ≤ P <sub>OUT</sub> ≤ 12 dBm	-4.5	—	4.5	
Control Level 14-15	VBATT = 3.5 V 0 dBm ≤ P <sub>OUT</sub> ≤ 2 dBm TCASE = +25 °C	0 dBm ≤ P <sub>OUT</sub> ≤ 2 dBm	-4.5	—	4.5		
		0 dBm ≤ P <sub>OUT</sub> ≤ 2 dBm	-5.5	—	5.5		
Power Control Slope	PCs	0 dBm to 31 dBm	—	—	250	dB/V	
<b>PCS1900 RECEIVE (f = 1930 MHz to 1990 MHz) = Rx Mode</b>							
Parameter	Symbol	Test Condition	Minimum	Typical	Maximum	Units	
Frequency Range	f	—	1930	—	1990	MHz	
Insertion Loss, ANT to Rx <sup>5,3</sup>	IL_Rx <sup>5</sup>	TCASE = +25 °C	—	1.2	1.5	dB	
VSWR ANT, Rx <sup>5,3</sup>	Γ <sub>IN</sub> , Γ <sub>OUT</sub>	—	—	1.2:1	1.5:1		

<sup>1</sup> Unless specified otherwise:  
TCASE = -20 °C to max. operating temperature (see Table 2); RL = 50 Ω; pulsed operation with pulse width ≤ 1154 μs and duty cycle ≤ 2:8; 3.1 V ≤ VCC ≤ 4.8 V.

<sup>2</sup> VRAMP is calibrated to each PCL at TCASE = +25 °C, VBATT = 3.5 V, PIN = 3 dBm, 50 Ω load.

<sup>3</sup> Terminate all unused RF ports with 50 Ω loads

<sup>4</sup> Max VRAMP = VRAMP @ P<sub>OUT</sub> = 31 dBm, 50 Ω load, TCASE +25 °C, VBATT = 3.5 V, PIN = 3 dBm

<sup>5</sup> Rx1 and Rx2 are broadband receive ports and each supports the GSM850, GSM900, DCS, and PCS bands.

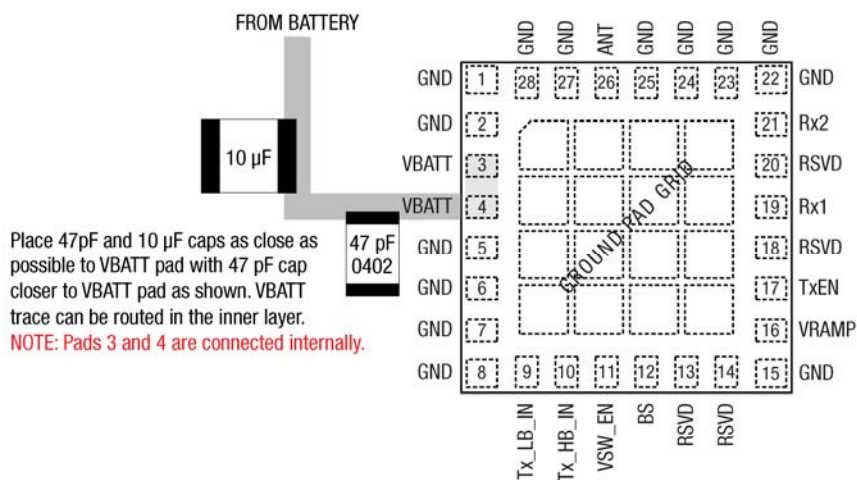

Pad layout as seen from Top View looking through package.

201138\_002

Figure 2. SKY77550 Application Schematic Diagram

**Package Dimensions**

Figure 3 is a mechanical diagram of the pad layout for the SKY77550, a 28-pad leadless dual-band FEM. Figure 4 provides a recommended phone board layout footprint for the FEM to help

the designer attain optimum thermal conductivity, good grounding, and minimum RF discontinuity for the 50-ohm terminals.

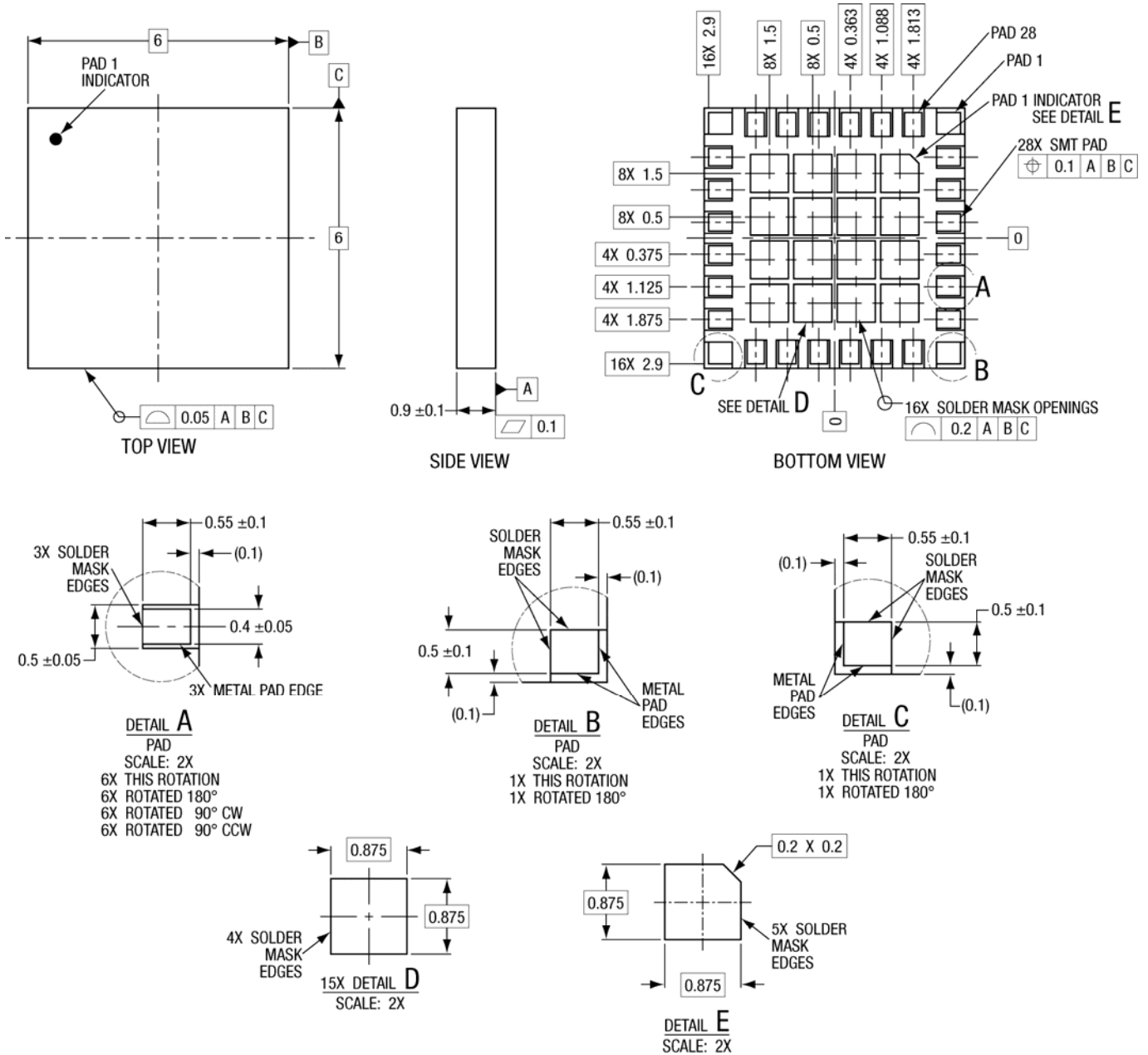

- NOTES: Unless otherwise specified.
1. Dimensioning and Tolerancing in accordance with ASME Y14.5M-1994.
  2. All dimensions are in millimeters.
  3. Pad definitions per details on drawing.

DS-0644-544 REV 1 01/20/09  
201138\_003

**Figure 3. Dimensional Drawing for 6 mm x 6 mm x 0.9 mm, 28-Pad Package – SKY77550 Specific (All Views)**

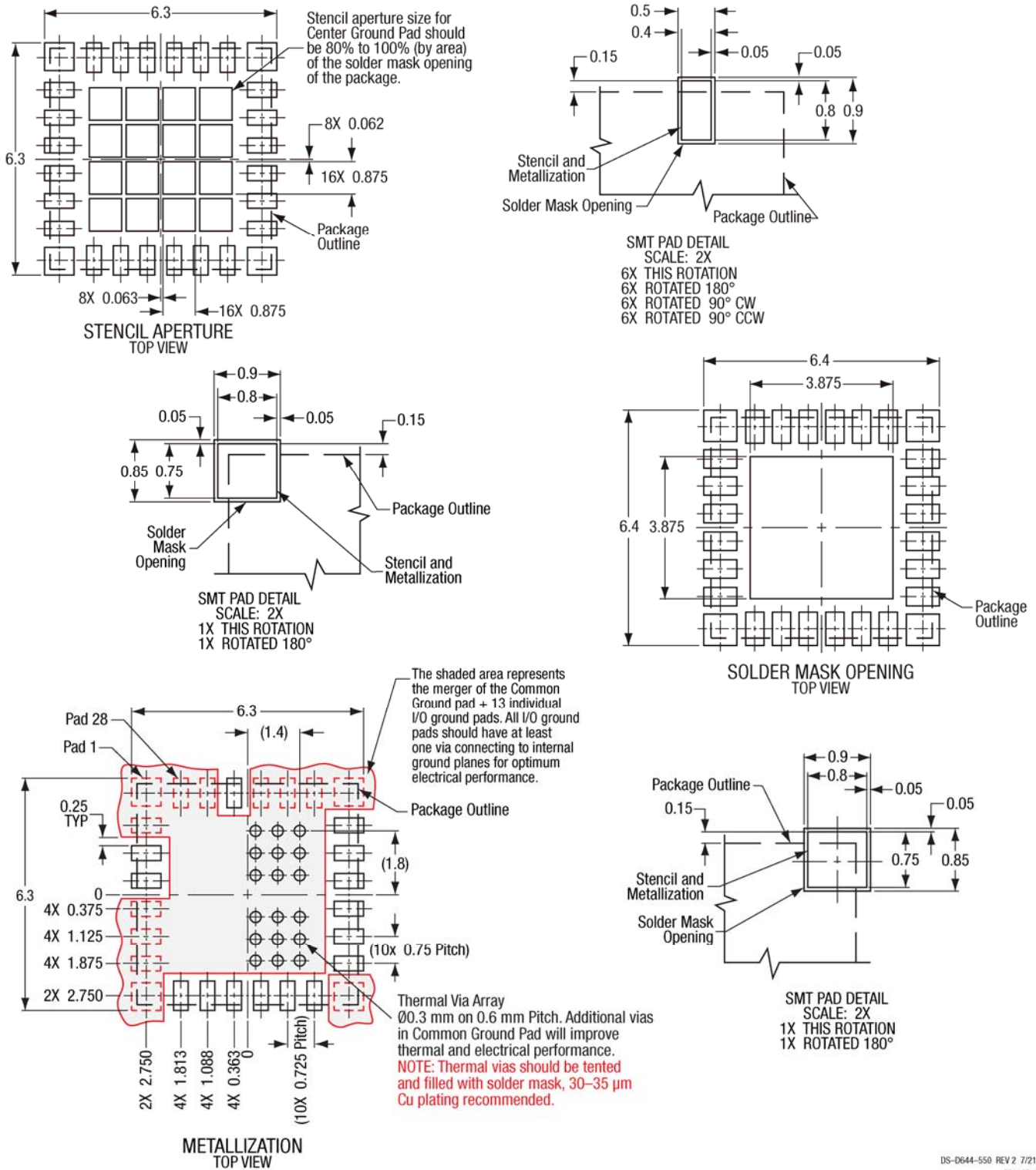

DS-D644-550 REV 2 7/21/10  
201138\_004

Figure 4. Phone PCB Layout Footprint for 6 mm x 6 mm, 28-Pad Package with Grid-Bottom Solder Mask – SKY77550 Specific.

**Package Description**

Figure 5 illustrates the device pad configuration and the numbering convention which starts with pad 1 at the lower left, as indicated and increments counter-clockwise around the package. Table 9 lists the pad names and the associated signal descriptions. Figure 6 interprets typical case markings.

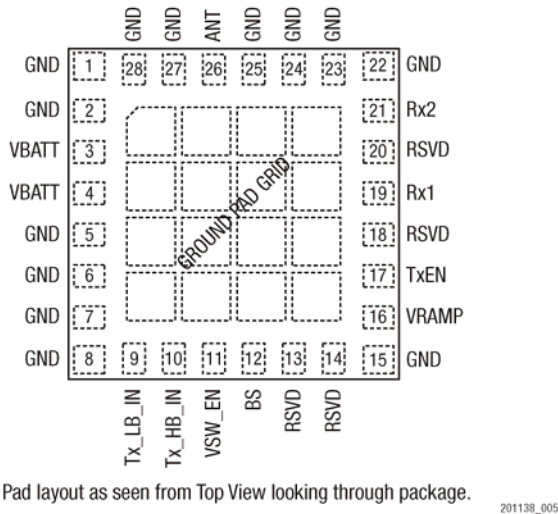

Pad layout as seen from Top View looking through package. 201138\_005

**Figure 5. SKY77550 FEM Pad Configuration – 28-Pad Leadless (Top View)**

**Table 9. SKY77550 Pad Names and Signal Descriptions**

Pad <sup>1</sup>	Name	Description
3, 4	VBATT	Battery input voltage (pads internally common)
9	Tx_LB_IN	RF input 824–915 MHz
10	Tx_HB_IN	RF input 1710–1910 MHz
11	VSW_EN	Control logic level selection/Standby control
12	BS	Band Select (mode control)
16	VRAMP	Analog power control voltage input
17	TxEN	Tx-Rx select (mode control)
19	Rx1	Broadband Receive Port
21	Rx2	Broadband Receive Port
26	ANT	RF_IN / RF_OUT to Antenna

<sup>1</sup> Pads 1, 2, 5–8, 15, 22–25, 27, 28 are ground pads. Pads 13, 14, 18, 20 are Reserved

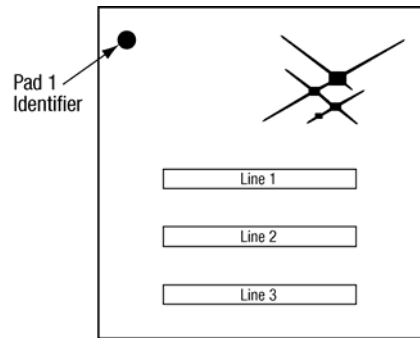

NOTE: Lines 1, 2, 3 have a maximum of 13 characters  
 Line 1 = Part Number and Version  
 Line 2 = Lot Number  
 Line 3 = Year–Week–Country Code (MX)

201138\_006

**Figure 6. Typical Case Markings**

**Package Handling Information**

Because of its sensitivity to moisture absorption, this device package is baked and vacuum-packed prior to shipment. Instructions on the shipping container label must be followed regarding exposure to moisture after the container seal is broken, otherwise, problems related to moisture absorption may occur when the part is subjected to high temperature during solder assembly.

The SKY77550 is capable of withstanding an MSL3/260 °C solder reflow. Care must be taken when attaching this product, whether it is done manually or in a production solder reflow environment. If the part is attached in a reflow oven, the temperature ramp rate should not exceed 3 °C per second; maximum temperature should not exceed 260 °C. If the part is manually attached, precaution should be taken to insure that the part is not subjected to temperatures exceeding 260 °C for more than 10 seconds. For details on attachment techniques, precautions, and handling procedures recommended by Skyworks, please refer to Skyworks Application Note: *PCB Design and SMT Assembly/Rework*, Document Number 101752. Additional information on standard SMT reflow profiles can also be found in the JEDEC *Joint Industry Standard J-STD-020*.

Production quantities of this product are shipped in the standard tape-and-reel format (Figure 7).



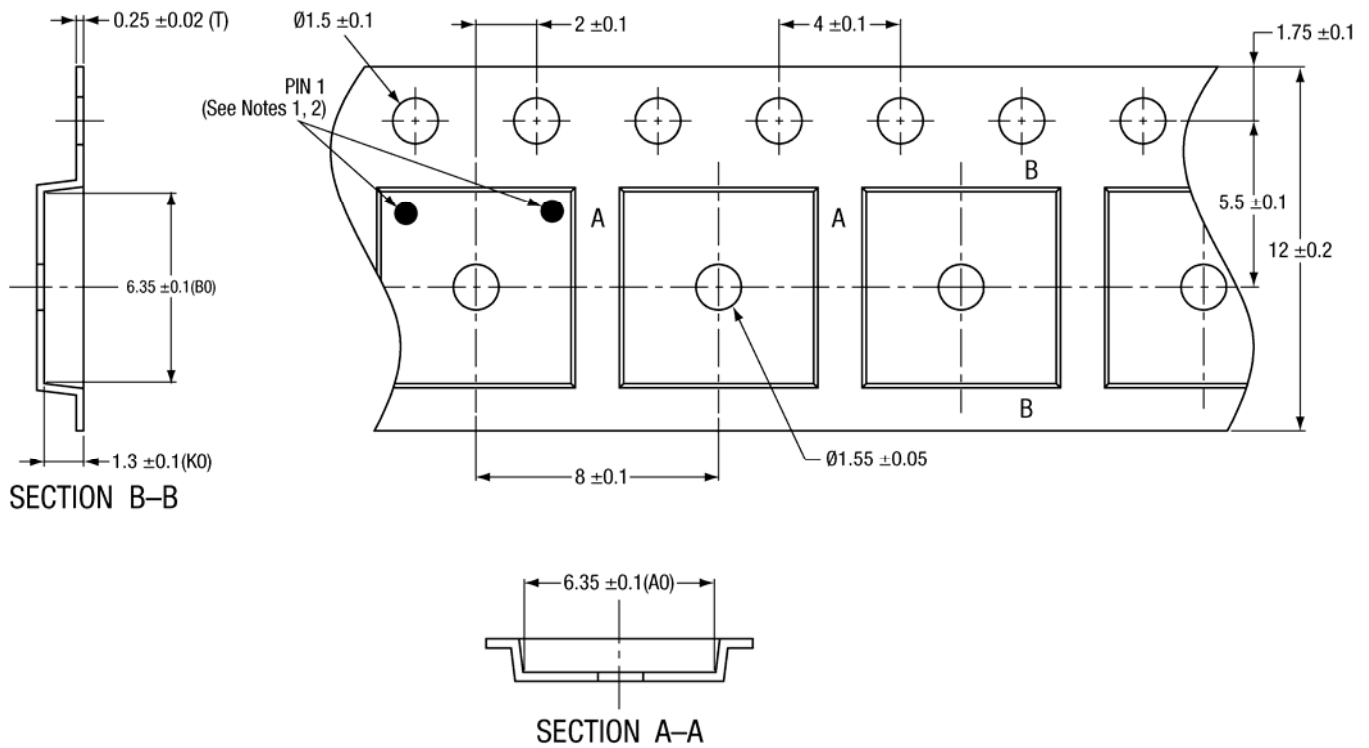

NOTES:

1. PIN 1 ORIENTATION IS "TOP LEFT" ONLY FOR RFLGA & MCM PRODUCTS LISTED BELOW:  
 SKY73022-21 SKY73022-31  
 SKY73023-21 SKY73023-31
2. PIN 1 ORIENTATION IS "TOP RIGHT" FOR ALL 6 x 6 mm RFLGA & MCM PRODUCTS EXCEPT THOSE LISTED IN NOTE 1 ABOVE.
3. CARRIER TAPE IS BLACK CONDUCTIVE POLYCARBONATE OR POLYSTYRENE.
4. COVER TAPE IS TRANSPARENT AND CONDUCTIVE.
5. ESD-SURFACE RESISTIVITY IS  $\leq 1 \times 10^{10}$  OHMS/SQUARE PER EIA, JEDEC TNR SPECIFICATION.
6. ALL DIMENSIONS ARE IN MILLIMETERS.

CARRIER TAPE OVERMOLD MCM/RFLGA 6 x 6 x 0.85 / 1.1 mm BODY SIZE -193G  
 201138\_008

**Figure 7. Dimensional Diagram for Carrier Tape Body Size 6 mm x 6 mm x 0.85 / 1.1 mm – MCM**

**Electrostatic Discharge (ESD) Sensitivity**

To avoid ESD damage, both latent and visible, it is very important that the product assembly and test areas follow the ESD handling precautions listed below.

- Personnel Grounding
  - Wrist Straps
  - Conductive Smocks, Gloves and Finger Cots
  - Antistatic ID Badges
- Protective Workstation
  - Dissipative Table Top
  - Protective Test Equipment (Properly Grounded)
  - Grounded Tip Soldering Irons
  - Solder Conductive Suckers
  - Static Sensors
- Facility
  - Relative Humidity Control and Air Ionizers
  - Dissipative Floors (less than 109  $\Omega$  to GND)
- Protective Packaging and Transportation
  - Bags and Pouches (Faraday Shield)
  - Protective Tote Boxes (Conductive Static Shielding)
  - Protective Trays
  - Grounded Carts
  - Protective Work Order Holders

## Ordering Information

Model Number	Manufacturing Part Number	Product Revision	Package	Operating Temperature
SKY77550	SKY77550		MCM 6 mm x 6 mm x 0.9	-20 °C to +85 °C

## Revision History

Revision	Date	Description
A	October 27, 2009	Initial Release – Advance Information
B	November 9, 2009	Revise: Figure 4
C	April 11, 2010	Revise: Description (p1); Tables 2–8
D	May June 14, 2010	Revise: Change Data Sheet status to “Preliminary” from “Advance”; Description, Features list (p1); Figure 2; Tables 4–9; References
E	September 8, 2010	Revise: Features list (p1); Tables 4–8; Figures 4, 7

## References

Skyworks Application Note: PCB Design and SMT Assembly/Rework, Document Number 101752

Skyworks Application Note: iPAC™ Peak Output Power Calibration, Document Number 103180

Skyworks Application Note: SKY77550 BiFET iPAC™ Front-End Module – Implementation, Document Number 201287

Standard SMT Reflow Profiles: JEDEC Standard J-STD-020

©2009, 2010, Skyworks Solutions, Inc. All Rights Reserved

Information in this document is provided in connection with Skyworks Solutions, Inc. (“Skyworks”) products or services. These materials, including the information contained herein, are provided by Skyworks as a service to its customers and may be used for informational purposes only by the customer. Skyworks assumes no responsibility for errors or omissions in these materials or the information contained herein. Skyworks may change its documentation, products, services, specifications or product descriptions at any time, without notice. Skyworks makes no commitment to update the materials or information and shall have no responsibility whatsoever for conflicts, incompatibilities, or other difficulties arising from any future changes.

No license, whether express, implied, by estoppel or otherwise, is granted to any intellectual property rights by this document. Skyworks assumes no liability for any materials, products or information provided hereunder, including the sale, distribution, reproduction or use of Skyworks products, information or materials, except as may be provided in Skyworks Terms and Conditions of Sale.

THE MATERIALS, PRODUCTS AND INFORMATION ARE PROVIDED “AS IS” WITHOUT WARRANTY OF ANY KIND, WHETHER EXPRESS, IMPLIED, STATUTORY, OR OTHERWISE, INCLUDING FITNESS FOR A PARTICULAR PURPOSE OR USE, MERCHANTABILITY, PERFORMANCE, QUALITY OR NON-INFRINGEMENT OF ANY INTELLECTUAL PROPERTY RIGHT; ALL SUCH WARRANTIES ARE HEREBY EXPRESSLY DISCLAIMED. SKYWORKS DOES NOT WARRANT THE ACCURACY OR COMPLETENESS OF THE INFORMATION, TEXT, GRAPHICS OR OTHER ITEMS CONTAINED WITHIN THESE MATERIALS. SKYWORKS SHALL NOT BE LIABLE FOR ANY DAMAGES, INCLUDING BUT NOT LIMITED TO ANY SPECIAL, INDIRECT, INCIDENTAL, STATUTORY, OR CONSEQUENTIAL DAMAGES, INCLUDING WITHOUT LIMITATION, LOST REVENUES OR LOST PROFITS THAT MAY RESULT FROM THE USE OF THE MATERIALS OR INFORMATION, WHETHER OR NOT THE RECIPIENT OF MATERIALS HAS BEEN ADVISED OF THE POSSIBILITY OF SUCH DAMAGE.

Skyworks products are not intended for use in medical, lifesaving or life-sustaining applications, or other equipment in which the failure of the Skyworks products could lead to personal injury, death, physical or environmental damage. Skyworks customers using or selling Skyworks products for use in such applications do so at their own risk and agree to fully indemnify Skyworks for any damages resulting from such improper use or sale.

Customers are responsible for their products and applications using Skyworks products, which may deviate from published specifications as a result of design defects, errors, or operation of products outside of published parameters or design specifications. Customers should include design and operating safeguards to minimize these and other risks. Skyworks assumes no liability for applications assistance, customer product design, or damage to any equipment resulting from the use of Skyworks products outside of stated published specifications or parameters.

Skyworks, the Skyworks symbol, “Breakthrough Simplicity,” DCR, Helios, HIP3, Innovation to Go, Intera, iPAC, LIPA, Polar Loop, and System Smart are trademarks or registered trademarks of Skyworks Solutions, Inc., in the United States and other countries. Third-party brands and names are for identification purposes only, and are the property of their respective owners. Additional information, including relevant terms and conditions, posted at [www.skyworksinc.com](http://www.skyworksinc.com), are incorporated by reference.