



SPECIFICATION

DVB-T Diversity Receiver

1.SCOPE

The DY-9080F is intended for the reception of DVB-T compliant MPEG2 signals (full TES 300 744 compliant) in combination with the tuner ,all functions are integrated to deliver a corrected stream given DVB-T encoded signal(2k or 8k mode)with 6,7,8 MHz bandwidth.
The Receiver for mobile application.

2.GENERAL SPECIFICATIONS

- | | |
|--|--|
| 2-1. RECEIVING FREQUENCY RANGE | :VHF 174~227MHz
UHF 474~858MHz |
| 2-2. SUPPLY VOLTAGE | :B1 3.3V +/- 0.1V Ripple < 10mV |
| 2-3. CONSUMPTION CURRENT | :B1 3.3V 492 mA typ |
| 2-4. OPERATION AND STORAGE
CONDITIONS FOR GUARANTEE | TEMPERATURE 0~50°C
HUMIDITY 85% OR LESS |

3.TEST CONDITIONS

3-1. TESTING AMBIENT CONDITIONS

DEFINED AS TEMPERATURE OF 25+/-2°C AND HUMIDITY OF 65+/-5% RH.

NOTE : THAT TEMPERATURES OF 5~30°C AND HUMIDITY OF 45~85% MAY BE REGARDED AS STANDARD.

SPECIFICATION
DVB-T Diversity Receiver

4. Electrical Specifications

Electrical Characteristics Control refer to DiBcom 9080M date sheet, and MT2266 data sheet

Circuit block diagram

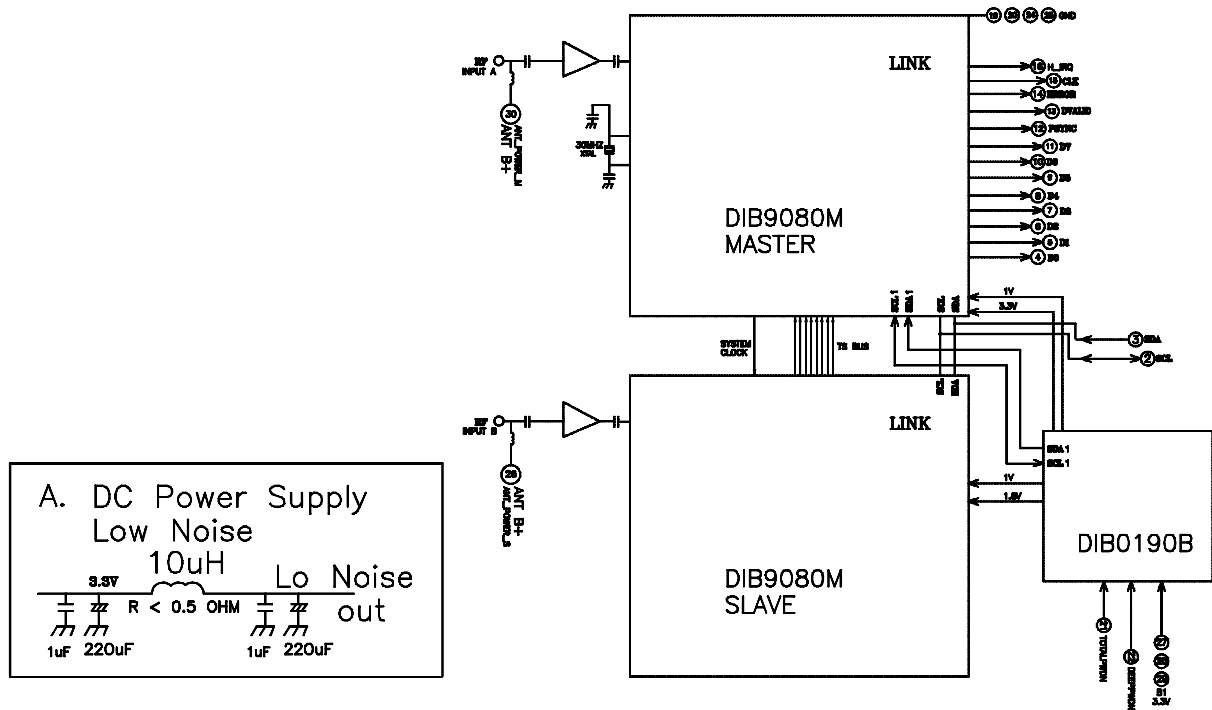

NO	ITEM	CONDITION	MIN	TYP	MAX	NOTES
4.1	Input sensitivity	Band width 8MHz FET mode 8K Guard interval 1/8 FEC code rate 2/3 RS uncorrected error=0 Constellation 64QAM 16 QAM QPSK	-78 -83 -88	-81 -86 -91		dBm dBm dBm
4.2	Performance with AWGN	C/N at antenna input		20		dB
4.3	protection from co-channel PAL	PAL-I 75% bars, fm sound 1KHz		4		dB
4.4	protection from adjacent channel PAL	PAL-i 75% bars, FM sound 1KHz		-35		dB
4.5	protection from adjacent DVB-T			-25		dB
4.6	protection from image Channel PAL	PAL-I 75% color bars, FM sound 1KHz		-46		dB
4.7	Performance with single echo inside the interval 2K mode	Te=Tg included (7.2us) Delay phase=0°		1.5		dB
4.8	Performance with single echo inside the interval	Te-Tsymbo 1/2 Delay phase=0°		19.5		dB
4.9	Typical multi-path channel	Additional END		4.0		dB

SPECIFICATION
DVB-T Diversity Receiver

5. Electrical Specification (Doppler Performance)

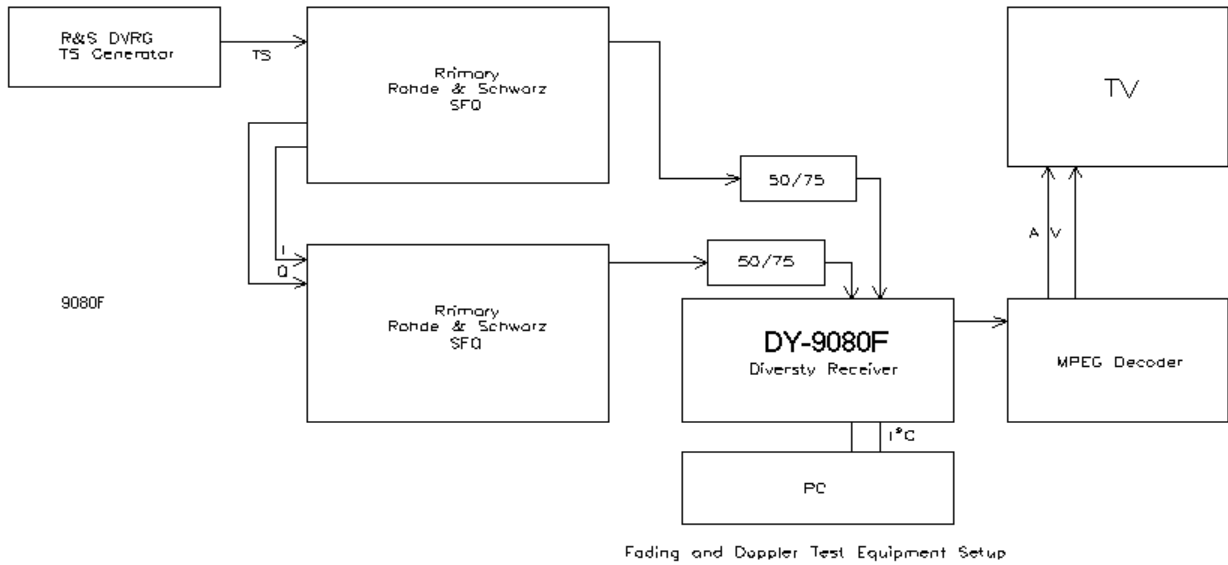

Typical Urban reception (TU6)

This profile reproduces the terrestrial propagation in an urban area. It has been defined by COST207 as a Typical Urban (TU6) profile and is made of 6 paths having wide dispersion in delay and relatively strong power. **[Reference 1]**

Tap number	Delay (us)	Power (dB)	Doppler spectrum
1	0.0	-3	Rayleigh
2	0.2	0	Rayleigh
3	0.5	-2	Rayleigh
4	1.6	-6	Rayleigh
5	2.3	-8	Rayleigh
6	5.0	-10	Rayleigh

Typical Urban profile (TU6) constitution

SPECIFICATION
DVB-T Diversity Receiver

Rural Area reception (RA6)

This profile reproduces the terrestrial propagation in a rural area. It has been defined by COST207 as a Rural Area (RA6) profile and is made of 6 paths having relatively short delay and small power. **[Reference 1]**

Tap number	Delay (us)	Power (dB)	Doppler spectrum
1	0.0	0	Rice
2	0.1	-4	Rayleigh
3	0.2	-8	Rayleigh
4	0.3	-12	Rayleigh
5	0.4	-16	Rayleigh
6	0.5	-20	Rayleigh

Table 2: Rural Area profile (RA6) constitution

0dB Echo with Doppler

This profile has been defined by member of the Motivate group. The 0dB echo profile is then made of two rays having the same power, delayed from half the Guard Interval value and presenting a pure Doppler characteristic. The Doppler frequency f_d is defined to be half the frequency separation of the two paths. **[Reference 1]**

Tap number	Delay (us)	Power (dB)	Doppler spectrum	Frequency ratio
1	0	0	Pure Doppler	-1
2	1/2 T _g	0	Pure Doppler	+1

Table 3: 0 dB echo with Doppler profile constitution

SPECIFICATION

DVB-T Diversity Receiver

Results

Typical Urban Reception (TU6) Results

The following results are the Doppler Frequency to achieve the point of failure of 1 picture artefact or error in a 20 second time period.

Modulation Mode	typ
8K 64QAM, FEC 1/2 and Guard Band 1/8	45Hz
8K 64QAM, FEC 2/3 and Guard Band 1/8	26Hz
2K 64QAM, FEC 2/3 and Guard Band 1/32	128Hz
2K 16QAM, FEC 3/4 and Guard Band 1/32	195Hz

Rural Area Reception (RA6) Results

The following results are the Doppler Frequency to achieve the point of failure of 1 picture artefact or error in a 20 second time period.

Modulation Mode	typ
8K 64QAM, FEC 1/2 and Guard Band 1/8	30Hz
8K 64QAM, FEC 2/3 and Guard Band 1/8	20Hz
2K 64QAM, FEC 2/3 and Guard Band 1/32	86Hz
2K 16QAM, FEC 3/4 and Guard Band 1/32	119Hz

0dB Echo With Doppler Reception (0dB) Results

The following results are the Doppler Frequency to achieve the point of failure of 1 picture artefact or error in a 20 second time period.

Modulation Mode	typ
8K 64QAM, FEC 1/2 and Guard Band 1/8	50Hz
8K 64QAM, FEC 2/3 and Guard Band 1/8	43Hz
2K 64QAM, FEC 2/3 and Guard Band 1/32	160Hz
2K 16QAM, FEC 3/4 and Guard Band 1/32	233Hz



SPECIFICATION

DVB-T Diversity Receiver

6. **Electrostatic discharge**

6.1 **Test**

Each front-end must be capable of normal performance following its subsection to the following tests:

MIL STD 883C HBM

Test is performed with a voltage discharge from a 100**PF** capacitor over a 1500**OHM** series resistance in the discharge path. There is a direct contact between the test probe head and the unit under test, using the test points and conditions detailed below:

- o Test to pins 1 through 30:
3 successive ESD discharges of **+/-2 KVDC** between each pin and the front-end frame.

IEC 1000-4-2

Test is performed with a voltage discharge from a 150**PF** capacitor over a 330**OHM** series resistance in the discharge path. There is a direct contact between the test probe head and the unit under test, using the test points and conditions detailed below:

- o Test for antenna input socket **+/-8 KVDC**

6.2 **Handling**

Anyone handling a front-end must wear a properly grounded anti-static discharge bracelet to minimize **ESD** damage.

After each front-end is aligned and tested, it will be packed with anti-static poly foam or material prior to transportation and storage. This protective foam is to remain in place until the front-end is assembled and soldered onto the receiver main board.

SPECIFICATION**DVB-T Diversity Receiver****7 Reliability test procedure & conditions**

Note: Room temperature = 25°C +/- 2°C

7.1 Heat load test

- o Measure the DUTs at room temperature
- o Load the DUTs into chamber of the following conditions:

Temperature = 60 °C
Period = 500 hrs
Cycle = 1.5 hrs on; 0.5 hrs off
Quantity = 10 pcs

- o Cool-down 0,5 hr at room temperature, then measured the DUTs within 1 hr
- o The test shall be continued to 1000 cycles for information only

7.2 Humidity load test

- o Measure the DUTs at room temperature
- o Load the DUTs into chamber of the following conditions:

Temperature = 40 +/- 5 °C
Period = 24 hrs
Cycle = constantly on
Quantity = 24 pcs

- o Cool-down 0.5 hr at room temperature, then measured the DUTs within 1 hr
- o Load the DUTs again into chamber of following conditions:

Temperature = 40 +/- 5 °C
Humidity = 90 to 95%
Period = 500 hrs
Cycle = 1.5 hrs on; 0.5 hrs off
Quantity = 20 pcs

- o Cool down 0.5hr at room temperature, then measured the DUTs within 1 hr

SPECIFICATION**DVB-T Diversity Receiver****7.6 Vibration test**

- o Frequency: 3.5 Hz
- o Vertical amplitude: 15 to 25 mm
- o Duration: 1 hr
- o Quantity: 1 carton

7.7 Drop test

- o Packaged apparatus: <or = 50 kg
- o Height: depend on weight
- o 1 corner + 3 edger + 6 faces

Drop on the weakest corner (point G)

Drop on the shortest edge on contact with point G

Drop on average edge in contact with point G

Drop on the longest edge in contact with point G

Drop flat wise on the side of minimum surface

Drop flat wise on the side of opposite minimum surface

Drop flat wise on the side of average surface

Drop flat wise on the side of opposite average surface

Drop flat wise on the side of maximum surface

Drop flat wise on the side of opposite maximum surface

- o Quantity :1 carton

7.8 Life test

- o Measure the DUTs at room temperature
- o Load the DUTs into chamber of the following conditions:

Temperature= 60 °C

Period = 500 hrs

Cycle = constantly on

Quantity = 20 pcs

- o Cool down 0.5 hr at room temperature, then measured the DUTs within 1hr

SPECIFICATION
DVB-T Diversity Receiver

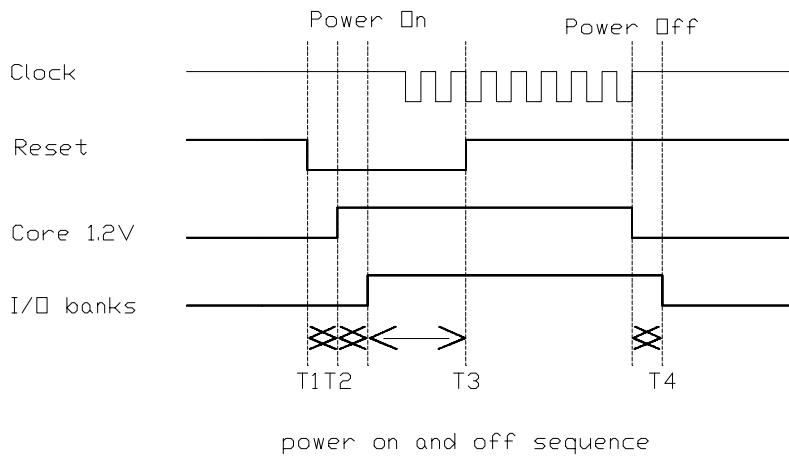

1. DiB IC can support I2C clock up to 1MHZ
2. After reset release,you can send immediatly I2C messages.Maybe wait 1-2 clock cycle before sending I2C message,just to be sure.
3. The only limit is $T3 > 10ms$.

SPECIFICATION
DVB-T Diversity Receiver

8.0 SPI interface

SPI signals	Description	Signal
CS	Host DiB9080M chip select(active low)	HOST_BUS12
VDD_SD	Power Flag	HOST_BUS7
CLK	Host clock to DiB9080M	HOST_BUS8
DATAIN	Host to DiB9080M data	HOST_BUS13
DATAOUT	DiB9080M to host data	HOST_BUS9
IRQ	DiB9080M to host	HOST_BUS10

8.1 SDIO interface

SD 1 bit	Description	Signal
VDD_SD	Power Flag	HOST_BUS7
CLK	Host clock to DiB9080M	HOST_BUS8
CMD	Bidirectional command / response signal	HOST_BUS13
DATA_0	Bidirectional data	HOST_BUS9
IRQ	DiB9080M to host	HOST_BUS10

SD 4 bit	Description	Signal
VDD_SD	Power Flag	HOST_BUS7
CLK	Host clock to DiB9080M	HOST_BUS8
CMD	Bidirectional command / response signal	HOST_BUS13
DATA_0	Bidirectional data	HOST_BUS9
DATA_1	Bidirectional data	HOST_BUS10
DATA_2	Bidirectional data	HOST_BUS11
DATA_3	Bidirectional data	HOST_BUS12
IRQ	DiB9080M to host	HOST_BUS14

8.2 Transport stream serial output

- MPDATA [0]:MPEG2-TS data bits (msb first)
- MPDATA [1]:bit-envelope of the 204 bytes
- MPDATA [2]:bit-envelope of the 188 bytes
- MPDATA [3]:msb position of the 204 bytes
- MPDATA [4]:msb position of the 188 bytes
- MPDATA [5]:clock gated with MPDATA [1]
- MPDATA [6]:clock gated with MPDATA [2]
- MPDATA [7]:60 MHz clock (not gated reference clock of the circuit)
- MPSTR: envelope of the start byte
- MPFRM: envelope of the 188 bytes
- MPCLK: byte pseudo-clock (high jitter)

SPECIFICATION

DVB-T Diversity Receiver

8.3 DVB-T parallel output

All DVB-T output signals mapped on HOST_BUS as depicted in the table below:

I²C + DVB-T output Signal	HOUS_BUS
SDA	HOUS_BUS0
SCL	HOUS_BUS1
DATA [0]	HOUS_BUS2
DATA [1]	HOUS_BUS3
DATA [2]	HOUS_BUS4
DATA [3]	HOUS_BUS5
DATA [4]	HOUS_BUS6
DATA [5]	HOUS_BUS7
DATA [6]	HOUS_BUS8
DATA [7]	HOUS_BUS9
CTRL[0]	HOUS_BUS10
CTRL[1]	HOUS_BUS11
CTRL[2]	HOUS_BUS12
CTRL[3]	HOUS_BUS13
IRQ	HOUS_BUS14

8.4 DVB-T output with the following options:

I²C + DVB-T output Signal	HOST_BUS
SDA	HOST_BUS0
SCL	HOST_BUS1
MPDATA[0]	HOST_BUS2
MPDATA[1]	HOST_BUS3
MPDATA[2]	HOST_BUS4
MPDATA[3]	HOST_BUS5
MPDATA[4]	HOST_BUS6
MPDATA[5]	HOST_BUS7
MPDATA[6]	HOST_BUS8
MPDATA[7]	HOST_BUS9
VAUD	HOST_BUS10
SYNC	HOST_BUS11
CLK	HOST_BUS12
ERROR	HOST_BUS13
IRQ	HOST_BUS14
REVERED	HOST_BUS15

SPECIFICATION

DVB-T Diversity Receiver

