

SHARP SERVICE MANUAL

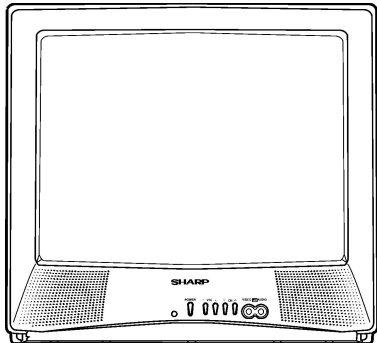

COLOR TELEVISION

Chassis No. SN-80

MODELS 20MU11

In the interests of user-safety (Required by safety regulations in some countries) the set should be restored to its original condition and only parts identical to those specified should be used.

CONTENTS

	Page
• ELECTRICAL SPECIFICATIONS	1
• IMPORTANT SERVICE SAFETY PRECAUTION	2
• LOCATION OF USER'S CONTROL	6
• INSTALLATION AND SERVICE INSTRUCTIONS	7
• CHASSIS LAYOUT	12
• BLOCK DIAGRAM	13
• SCHEMATIC DIAGRAMS	14
• PRINTED WIRING BOARD ASSEMBLIES	18
• REPLACEMENT PARTS LIST	23
• PACKING OF THE SET	35

ELECTRICAL SPECIFICATIONS

POWER INPUT 120 V AC 60 Hz
 POWER RATING 82 W
 PICTURE SIZE 1,194cm₂ (185sq inch)
 CONVERGENCE Magnetic
 SWEEP DEFLECTION Magnetic
 FOCUS Hi-Bi-Potential Electrostatic
 INTERMEDIATE FREQUENCIES
 Picture IF Carrier Frequency 45.75 MHz
 Sound IF Carrier Frequency 41.25 MHz
 Color Sub-Carrier Frequency 42.17 MHz
 (Nominal)

AUDIO POWER
 OUTPUT RATING 0.9 W (at 10% distortion)
 SPEAKER
 SIZE 8 cm (Round)
 VOICE COIL IMPEDANCE 8 ohm at 400 Hz
 ANTENNA INPUT IMPEDANCE
 VHF/UHF 75 ohm Unbalanced
 TUNING RANGES
 VHF-Channels 2 thru 13
 UHF-Channels 14 thru 69
 CATV Channels 1 thru 125
 (EIA, Channel Plan U.S.A.)

Specifications are subject to change without prior notice.

SHARP CORPORATION

This document has been published to be used for after sales service only.
 The contents are subject to change without notice.

IMPORTANT SERVICE SAFETY PRECAUTION

- **Service work should be performed only by qualified service technicians who are thoroughly familiar with all safety checks and the servicing guidelines which follow:**

WARNING

1. For continued safety, no modification of any circuit should be attempted.
2. Disconnect AC power before servicing.
3. Semiconductor heat sinks are potential shock hazards when the chassis is operating.
4. The chassis in this receiver has two ground systems which are separated by insulating material. The non-isolated (hot) ground system is for the B+ voltage regulator circuit and the horizontal output circuit. The isolated ground system is for the low B+ DC voltages and the secondary circuit of the high voltage transformer.

To prevent electrical shock use an isolation transformer between the line cord and power receptacle, when servicing this chassis.

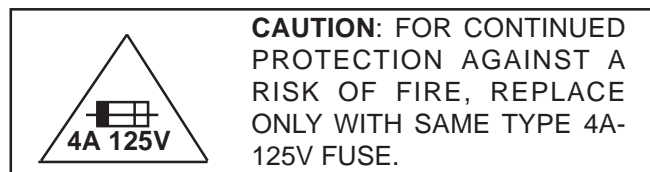

SERVICING OF HIGH VOLTAGE SYSTEM AND PICTURE TUBE

When servicing the high voltage system, remove the static charge by connecting a 10k ohm resistor in series with an insulated wire (such as a test probe) between the picture tube ground and the anode lead. (AC line cord should be disconnected from AC outlet.)

1. Picture tube in this receiver employs integral implosion protection.
2. Replace with tube of the same type number for continued safety.
3. Do not lift picture tube by the neck.
4. Handle the picture tube only when wearing shatterproof goggles and after discharging the high voltage anode completely.

X-RADIATION AND HIGH VOLTAGE LIMITS

1. Be sure all service personnel are aware of the procedures and instructions covering X-radiation. The only potential source of X-ray in current solid state TV receivers is the picture tube. However, the picture tube does not emit measurable X-Ray radiation, if the high voltage is as specified in the "High Voltage Check" instructions. It is only when high voltage is excessive that X-radiation is capable of penetrating the shell of the picture tube including the lead in the glass material. The important precaution is to keep the high voltage below the maximum level specified.
2. It is essential that servicemen have available at all times an accurate high voltage meter. The calibration of this meter should be checked periodically.
3. High voltage should always be kept at the rated value -no higher. Operation at higher voltages may cause a failure of the picture tube or high voltage circuitry and;also, under certain conditions, may produce radiation in exceeding of desirable levels.
4. When the high voltage regulator is operating properly there is no possibility of an X-radiation problem. Every time a color chassis is serviced, the brightness should be tested while monitoring the high voltage with a meter to be certain that the high voltage does not exceed the specified value and that it is regulating correctly.
5. Do not use a picture tube other than that specified or make unrecommended circuit modifications to the high voltage circuitry.
6. When troubleshooting and taking test measurements on a receiver with excessive high voltage, avoid being unnecessarily close to the receiver. Do not operate the receiver longer than is necessary to locate the cause of excessive voltage.

IMPORTANT SERVICE SAFETY PRECAUTION

(Continued)

BEFORE RETURNING THE RECEIVER

(Fire & Shock Hazard)

Before returning the receiver to the user, perform the following safety checks.

1. Inspect all lead dress to make certain that leads are not pinched or that hardware is not lodged between the chassis and other metal parts in the receiver.
2. Inspect all protective devices such as non-metallic control knobs, insulating materials, cabinet backs, adjustment and compartment covers or shields, isolation resistor-capacity networks, mechanical insulators and etc.
3. To be sure that no shock hazard exists, check for leakage current in the following manner.
 - Plug the AC cord directly into a 120 volt AC outlet, (Do not use an isolation transformer for this test).
 - Using two clip leads, connect a 1.5k ohm, 10 watt resistor paralleled by a 0.15mF capacitor in series with all exposed metal cabinet parts and a known earth ground, such as electrical conduit or electrical ground connected to earth ground.
 - Use an AC voltmeter having with 5000 ohm per volt, or higher, sensitivity to measure the AC voltage drop across the resistor.

- Connect the resistor connection to all exposed metal parts having a return to the chassis (antenna, metal cabinet, screw heads, knobs and control shafts, escutcheon and etc.) and measure the AC voltage drop across the resistor.

All checks must be repeated with the AC ine cord plug connection reversed. (If necessary, a non-polarized adapter plug must be used only for the purpose of completing these check.)

Any current measured must not exceed 0.5 milliamp. Any measurements not within the limits outlined above indicate of a potential shock hazard and corrective action must be taken before returning the instrument to the customer.

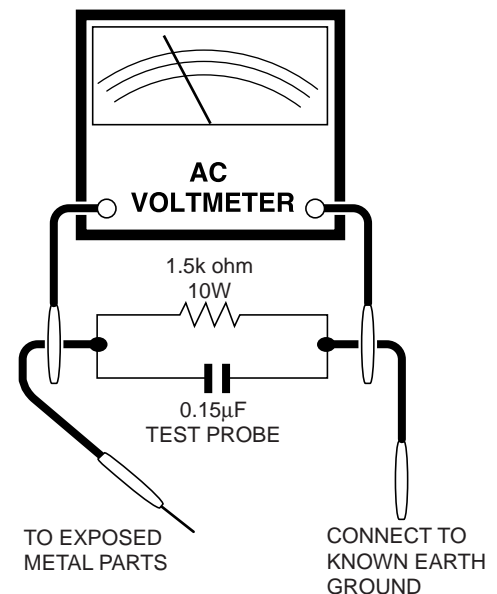

SAFETY NOTICE

Many electrical and mechanical parts in television receivers have special safety-related characteristics. These characteristics are often not evident from visual inspection, nor can protection afforded by them be necessarily increased by using replacement components rated for higher voltage, wattage and etc.

Replacement parts which have these special safety characteristics are identified in this manual; electrical components having such features are identified by "⚠" and shaded areas in the Replacement Parts Lists and Schematic Diagrams.

For continued protection, replacement parts must be identical to those used in the original circuit. The use of substitute replacement parts which do not have the same safety characteristics as the factory recommended replacement parts shown in this service manual, may create shock, fire, X-radiation or other hazards.

LOCATION OF USER'S CONTROL

Front Panel

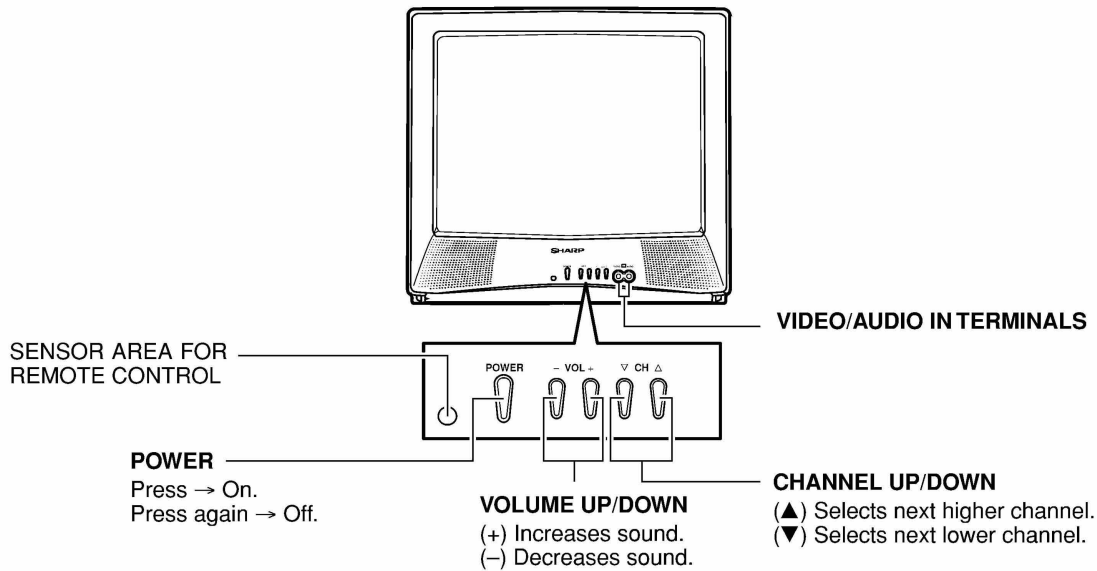

Basic Remote Control Functions

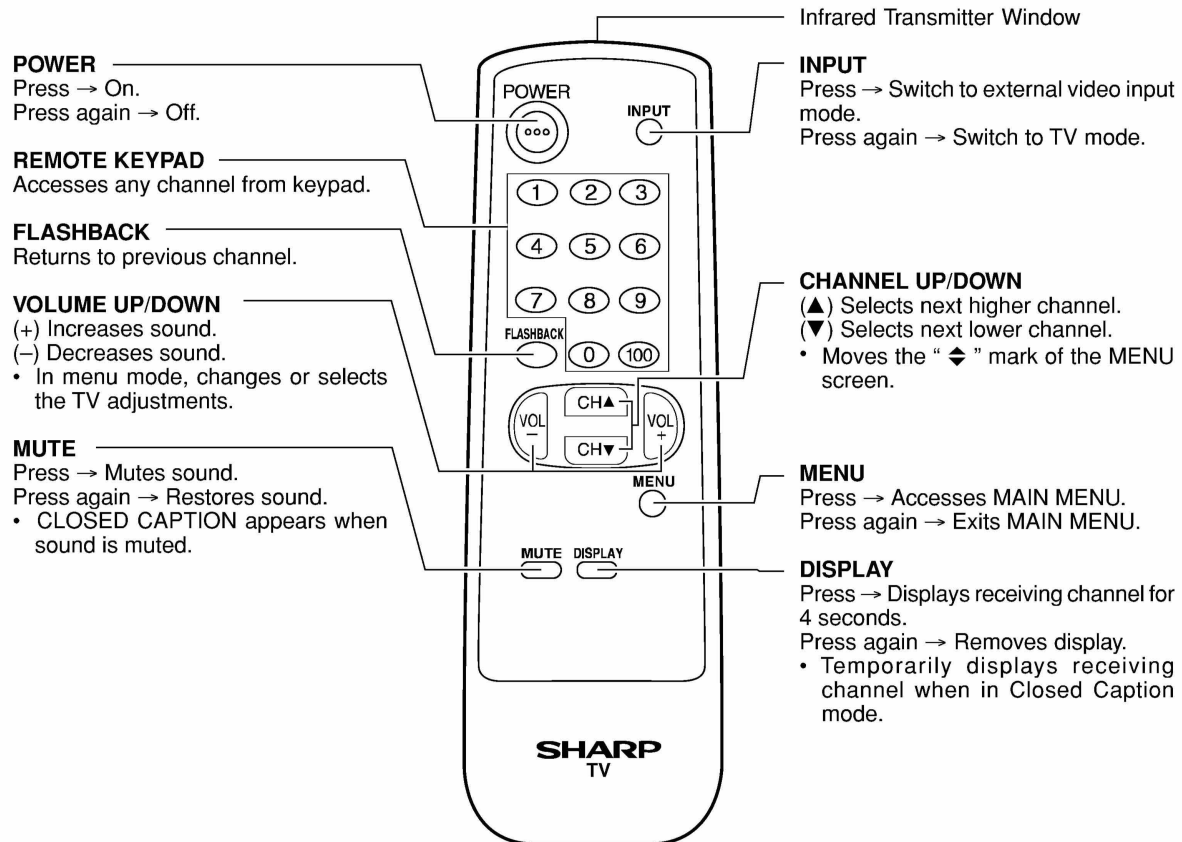

INSTALLATION AND SERVICE INSTRUCTIONS

Note: (1) When performing any adjustments to resistor controls and transformers use non-metallic screwdrivers or TV alignment tools.

(2) Before performing adjustments, the TV set must be on at least 15 minutes.

CIRCUIT PROTECTION

The receiver is protected by a 4.0A fuse (F701), mounted on PWB-A, wired into one side of the AC line input.

X-RADIATION PROTECTOR CIRCUIT TEST

After service has been performed on the horizontal deflection system, high voltage system, +B system, test the X-Radiation protection circuit to ascertain proper operation as follows:

- 1) Apply 120V AC using a variac transformer for accurate input voltage.
- 2) Allow for warm up and adjust all customer controls for normal picture and sound.
- 3) Receive a good local channel.
- 4) Connect a digital voltmeter to TP653 and make sure that the voltmeter reads 21.3 ± 1.5 V.
- 5) Apply external 28.9V DC at TP653 by using an external DC supply, TV must be shut off.
- 6) To reset the protector, unplug the AC cord and make a short circuit between TP651 and TP652. Now make sure that normal picture appears on the screen.
- 7) If the operation of the horizontal oscillator does not stop in step 5, the circuit must be repaired before the set is returned to the customer.

HIGH VOLTAGE CHECK

High voltage is not adjustable but must be checked to verify that the receiver is operating within safe and efficient design limitations as specified checks should be as follows:

1. Connect an accurate high voltage meter between ground and anode of picture tube.
2. Operate receiver for at least 15 minutes at 120V AC line voltage, with a strong air signal or a properly tuned in test signal.
3. Enter the service mode and select the service adjustment "S19" and Bus data "01" (Y-mute on).
4. The voltage should be approximately, 26.0kV (at zero beam).

If a correct reading cannot be obtained, check circuitry for malfunctioning components. After the voltage test, make Y-mute off to the normal mode.

For adjustments of this model, the bus data is converted to various analog signals by the D/A converter circuit.

Note: There are still a few analog adjustments in this series such as focus and master screen voltage. Follow the steps below whenever the service adjustment is required. See "Table-B" to determine, if service adjustments are required.

1. Service mode

Before putting unit into the service mode, check that customer adjustments are in the normal mode. Use the reset function in the video adjustment menu to ensure customer controls are in their proper (reset) position.

2. Service number selection

Once in the service mode, press the Ch-up or Ch-down button on the remote controller or at the set. The service adjustment number will vary in increments of one, from "S01" to "OP". Select the item you wish to adjust.

3. Data number selection

Press the Vol-up or down button to adjust the data number.

To enter the service mode and exit service mode.

While pressing the Vol-up and Ch-up buttons at the sametime, plug the AC cord into a wall socket. Now the TV set is switched on and enters the service mode.

To exit the service mode, turn the television off by pressing the power button.

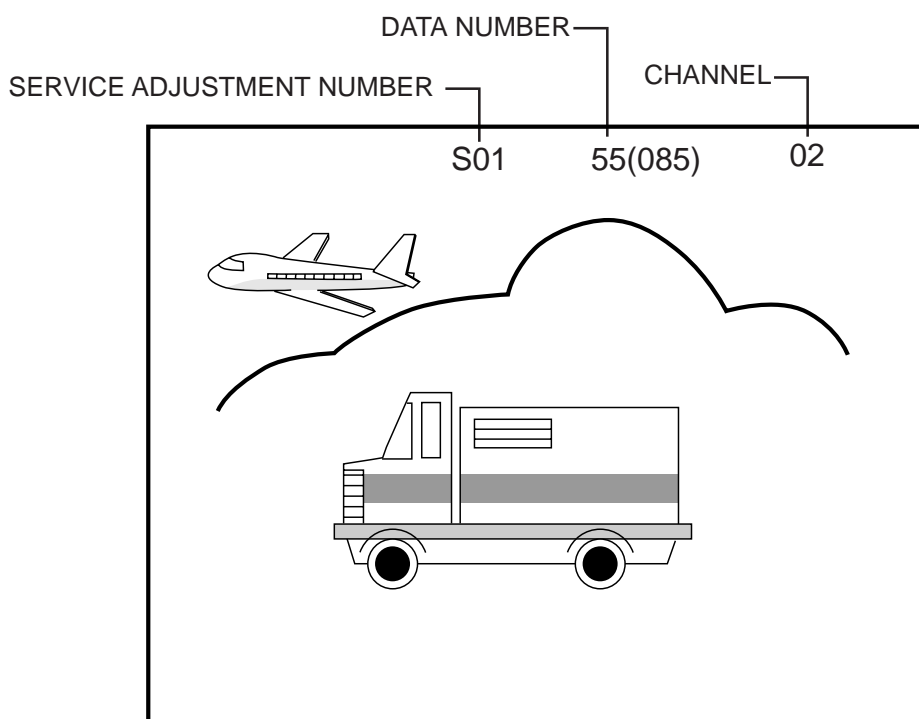

Figure A.

SERVICE NUMBER	ADJUSTMENT ITEM	DATA		ADJUSTMENT CONTENTS
		INITIAL VALUE	RANGE	
S01	PICTURE	55	00-7F	
S02	TINT	46	00-7F	
S03	COLOR	32	00-7F	
S04	BRIGHTNESS	40	00-7F	
S05	SHARPNESS	28	00-3F	Must be set to "24"
S06	VERTICAL PHASE	00	00-07	Must be set to "00" ~ "03"
S07	HORIZONTAL PHASE	12	00-1F	
S08	RF-AGC	23	00-3F	
S09	VERTICAL AMP	20	00-3F	
S10	VCO	2C	00-7F	
S11	R CUT-OFF	00	00-FF	
S12	G CUT -OFF	00	00-FF	
S13	B CUT-OFF	00	00-FF	
S14	G GAIN	7F	00-FF	
S15	B GAIN	7F	00-FF	
S16	TRAP(3.58MHz)	00	00 or 01	Must be set to "00"
S17	BALANCE	20	00-3F	Must be set to "20"
S18	C.C.POSITION	17	00-7F	
S19	Y-MUTE	00	00,01,03	"00" = NORMAL, "01" = No Y, "03" = No VERTICAL
S20	ENERGY SAVE OFFSET	20	00-3F	Must be set to "23"
S21	D.D.E. OFFSET	03	00-1F	Must be set to "03"
S22	OSD SETUP	00	00-03	Must be set to "00"
S23	TUNER SETUP	00	00-01	Must be set to "00"
OP	OPTION	30	00-FF	Must be set to "02"

Table - A

Holding down both the CH-up/down buttons on the TV set at service mode for more than 2 seconds will automatically write the above initial values into IC2101.

PART REPLACED	ADJUSTMENT		NOTES
	NECESSARY	UNNECESSARY	
IC2001		X	Data is stored in IC2101.
IC201	X		The adjustment is needed to compensate for characteristics of parts including IC201.
IC2101	X		Holding down both the CH-up/down buttons on the TV set in the service mode for more than 2 seconds will automatically write the above initial values into IC2101.
CRT	X		Adjust items related to picture tube only.

Table - B

■ SERVICE ADJUSTMENT

VCO Adjustment

1. Connect a digital voltmeter between pin (44) of IC201 and ground.
2. Receive a good local channel.
3. Enter the service mode and select the service adjustment "S10".
4. Adjust the data so that digital voltmeter reads 2.2V.
5. Adjustment is completed, remove the voltmeter, return to "normal" mode.

RF AGC Adjustment

1. Receive a good local channel.
2. Enter the service mode and select the service adjustment "S08".
3. Set the data value to point where no noise or beat appears.
4. Select another channel to confirm that no noise or beat appears.

Note 1: You will have to come out of the service mode to select another channel.

Note 2: Setting the data to "00" will produce a black raster.

Screen Adjustment

1. Connect a digital voltmeter between TP852 and TP853 on the CRT Unit.
Note: These test points may not be provided.
Then connect the voltmeter to both ends of R852 located near Q852 on the foil side.
2. Receive a good local channel.
3. Enter the service mode and select the service adjustment "S03" and set the data value to "00" to set the color level to minimum. (Record original data code under adjustment "S03" before changing) You may skip this step, if you selected a B/W picture or monoscope pattern.
4. Select the service adjustment "S19" and adjust the data value to "01", this turn off the luminance signal (Y-mute).
5. Select the service adjustment "S04" and adjust data value to obtain 0.17 volts on the digital voltmeter.
6. Adjust the master screen control until the raster darkens to the point where raster is barely seen.
7. Adjust the service adjustments "S11" red, "S12" green and "S13" blue to obtain a good grey scale with normal whites at low brightness level.
8. Select the service adjustment "S19" and reset data to "00". Select the service adjustment "S03" and reset data to obtain normal color level.
9. Remove digital voltmeter, and reset the master screen control to obtain normal brightness range.

White Balance Adjustment

1. Receive a good local channel.
2. Enter the service mode and select the service adjustment "S03" and set to "00" (minimum color)(Record original data code under adjustment "S03" before changing). "S03" does not have to be adjusted, if you selected a B/W picture or monoscope pattern.
3. Alternately adjust the service adjustment data of "S14" and "S15" until a good grey scale with normal whites is obtained.
4. Select the service adjustment "S03" and adjust data to obtain normal color level.

Sub-Picture Adjustment

1. Receive a good local channel.
2. Make sure the customer picture control is set to maximum.
3. Enter the service mode and select the service adjustment "S01".
4. Adjust the data value to achieve normal contrast range.

Sub-Tint Adjustment

1. Receive a good local channel.
2. Set customer tint control to center of it's range.
3. Enter the service mode and select the service adjustment "S02".
4. Adjust "S02" data value to obtain normal flesh tones.

Sub-Color Adjustment

1. Receive a good local channel.
2. Make sure the customer color control is set to center position .
3. Enter the service mode and select service adjustment "S03".
4. Adjust "S03" data value to obtain normal color level.

Sub-Brightness Adjustment

1. Receive a good local channel.
2. Make sure the customer brightness control is set to center position.
3. Enter the service mode and select the service adjustment "S04".
4. Adjust "S04" data value to obtain normal brightness level.

Vertical-Size Adjustment

1. Receive a good local channel.
2. Enter the service mode and select the service adjustment "S09".
3. While observing the top and bottom of the screen, adjust "S09" data value to proper vertical size.

Vertical Phase Adjustment

1. Enter the service mode and select the service adjustment "S06".
2. Adjust data value to "00" ~ "03".

Note: This must be set "00" ~ "03" when changed data retrace line will appear.

Horizontal Position Adjustment

1. Have unit receive a good local channel.
2. Enter the service mode and select the service adjustment "S07".
3. Adjust "S07" data value so that picture is centered.

Caption Position Adjustment (Horizontal)

1. Receive a good local channel.
2. Enter the service mode and select the service adjustment "S18".
3. A black text box appears on the screen. (see **Figure B.** below)
4. Adjust "S18" data value so that text box is positioned in the center of the screen.

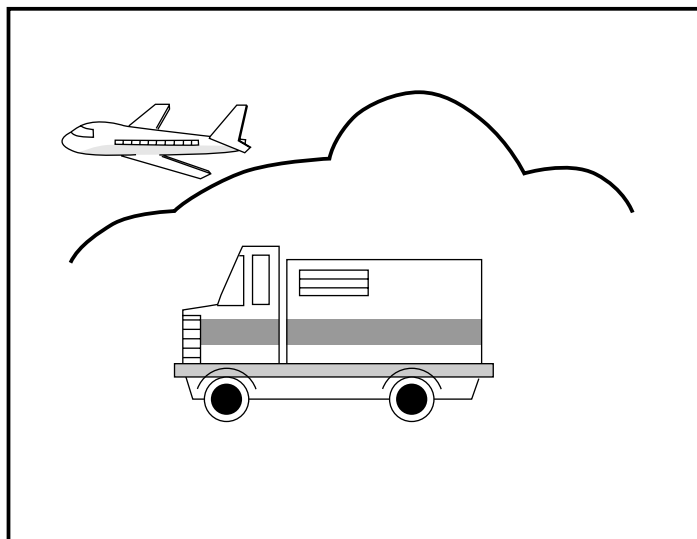

Figure B.

3.58MHz Trap Adjustment

1. Receive a good local channel.
2. Enter the service mode and select the service adjustment "S16".
3. This is a two position adjustment, "00" is ON, "01" is OFF.
4. Adjust data value to "00" for normal viewing.

Sharpness, Audio Balance, Energy Save Offset, DDE Offset, OSD Setup, Tuner Setup and Option Adjustments

1. Receive a good local channel.
2. Enter the service mode and select the service adjustments "S05" for sharpness, "S17" for balance, "S20" for energy save offset, "S21" for DDE offset, "S22" for OSD setup, "S23" for tuner and "OP" for option.

● Sharpness Adjustment

3. Adjust data value to "24" (center of data range) for sharpness adjustment.

● Audio Balance Adjustment

4. Adjust data value to "20" (center of data range) for audio balance adjustment.

● Energy Save Offset Adjustment

5. Adjust data value to "23".

● DDE Offset Adjustment

6. Adjust data value to "03".

● OSD Setup Adjustment

7. Adjust data value to "00".

● Tuner Setup Adjustment

8. Adjust data value to "00".

● Option Adjustment

9. Adjust data value to "02".

CHASSIS LAYOUT

20MU11

H
G
F
E
D
C
B
A

PWB-B

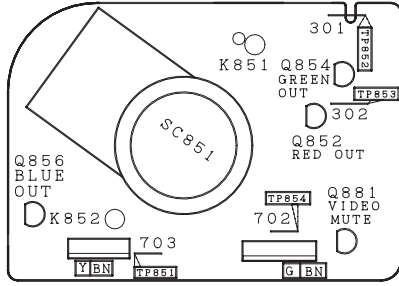

PWB-B

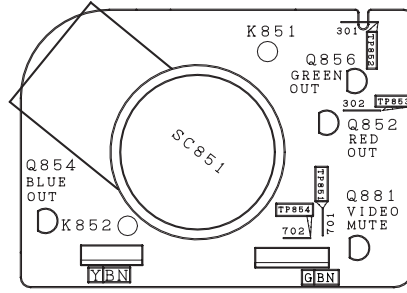

PWB-A

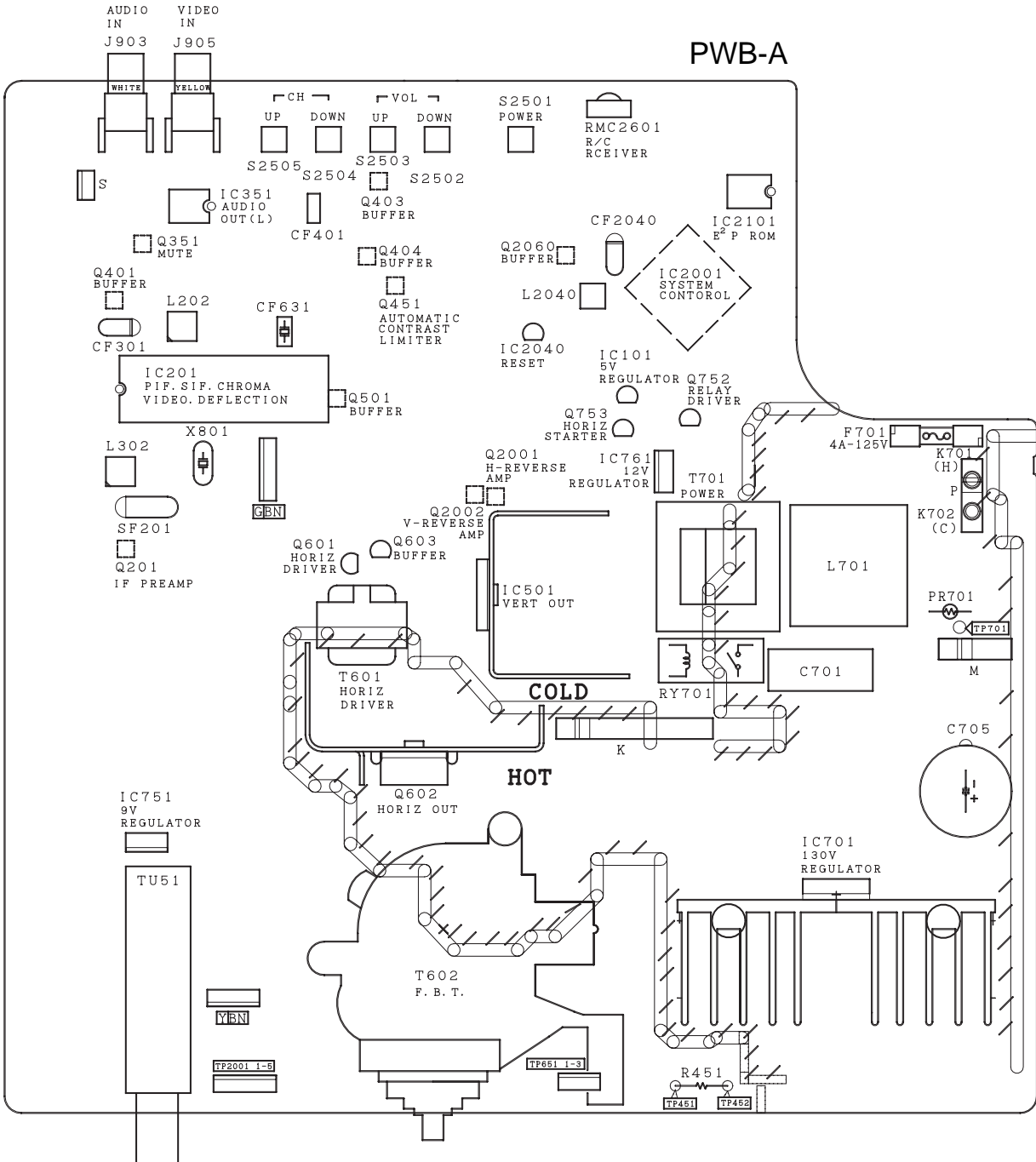

1 2 3 4 5 6

BLOCK DIAGRAM

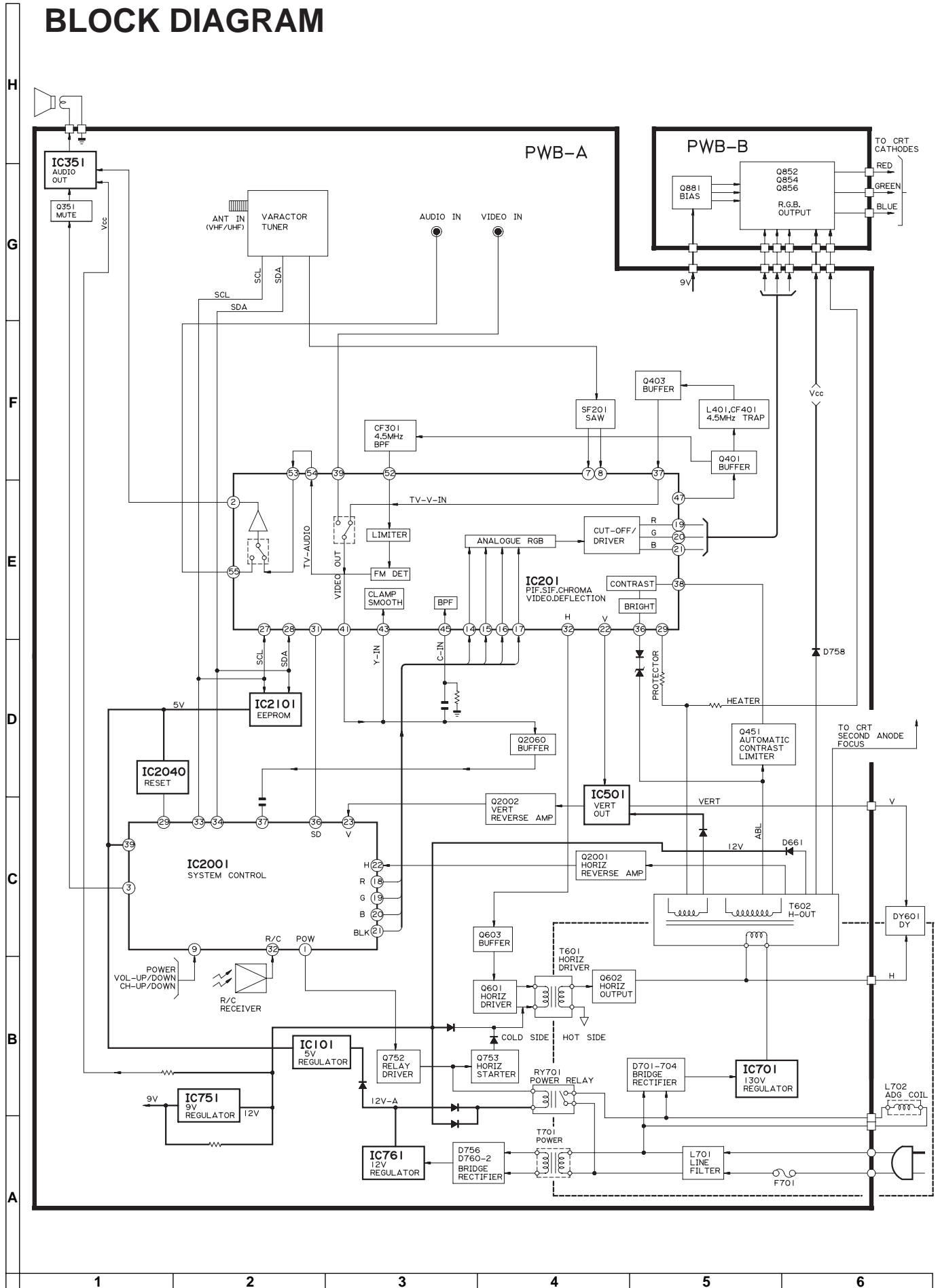

DESCRIPTION OF SCHEMATIC DIAGRAM

NOTES:

1. The unit of resistance "ohm" is omitted.
($K=k\Omega=1000\Omega$, $M=M\Omega$)
2. All resistors are 1/16 watt, unless otherwise noted.
3. All capacitors are μF , unless otherwise noted.
($P=pF=\mu\mu F$)
4. (G) indicates $\pm 2\%$ tolerance may be used.
5. \perp indicates line isolated ground.
6. \downarrow indicates hot ground.

VOLTAGE MEASUREMENT CONDITIONS:

1. All DC voltages are measured with DVM connected between points indicated and chassis ground, line voltage set at 120V AC and all controls set for normal picture unless otherwise indicated.
2. All voltages measured with 1000 μ V B & W or Color signal.

WAVEFORM MEASUREMENT CONDITIONS:

1. Photographs taken on a standard gated color bar signal, the tint setting adjusted for proper color. The wave shapes at the red, green and blue cathodes of the picture tube depend on the tint, color level and picture control.
2. \odot indicates waveform check points (See chart, waveforms are measured from point indicated to chassis ground.)

\triangle AND SHADED () COMPONENTS
= SAFETY RELATED PARTS.
 \blacktriangle MARK= X-RAY RELATED PARTS.

DRGANNES MARQUES \triangle ET HACHRES ():
PIECES RELATIVES A LA SECURITE.
MARQUE \blacktriangle : PIECS RELATIVE AUX RAYONS X.

This circuit diagram is a standard one, printed circuits may be subject to change for product improvement without prior notice.

WAVEFORMS

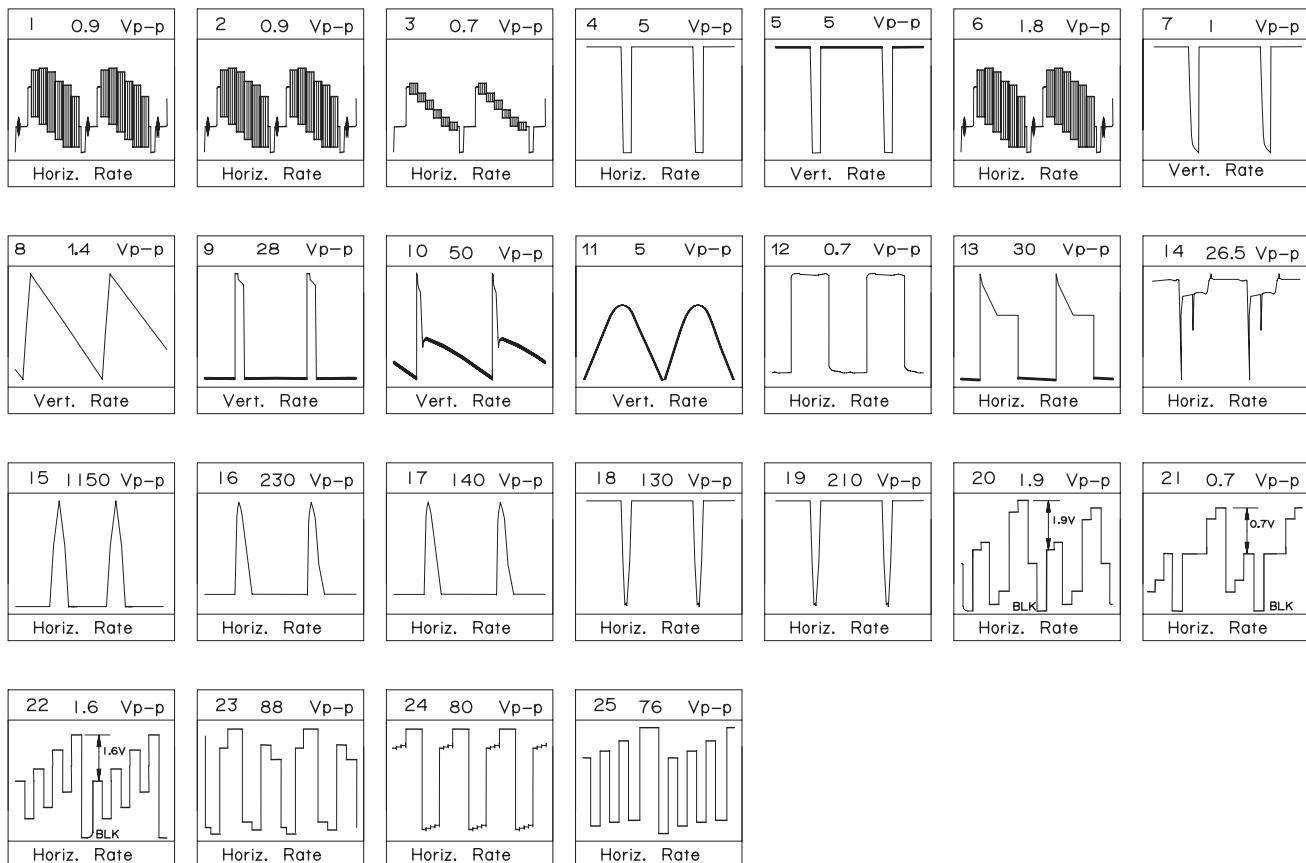

H
G
F
E
D
C
B
A

20MU11

CRTS

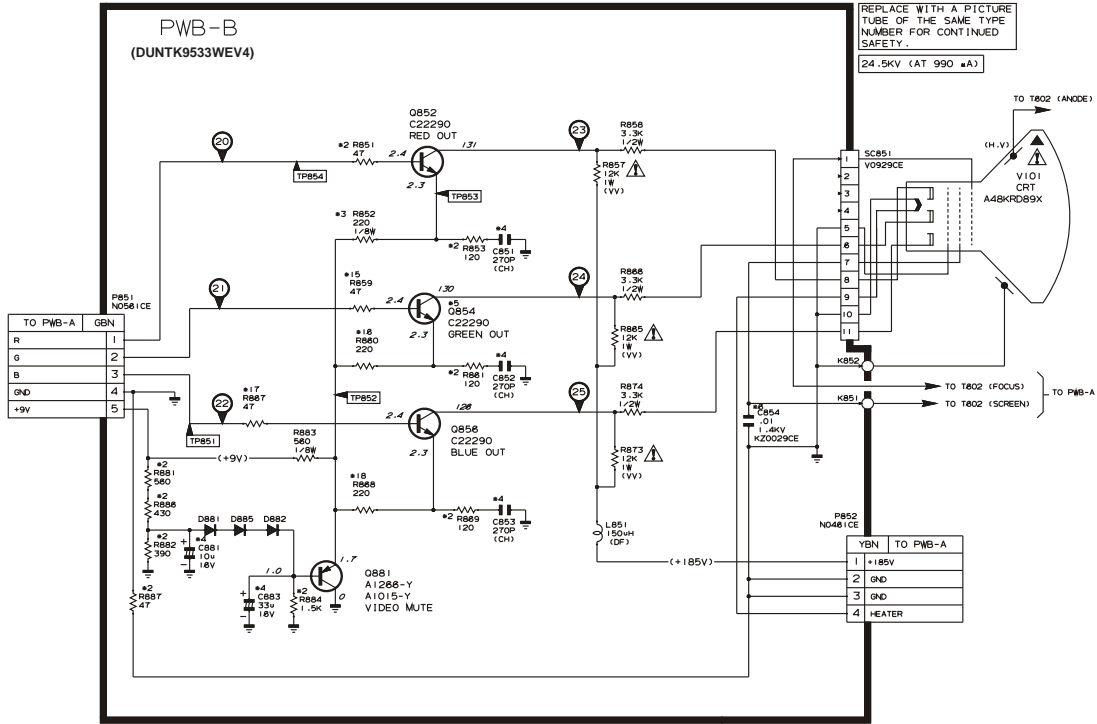

20MU11

CRT0

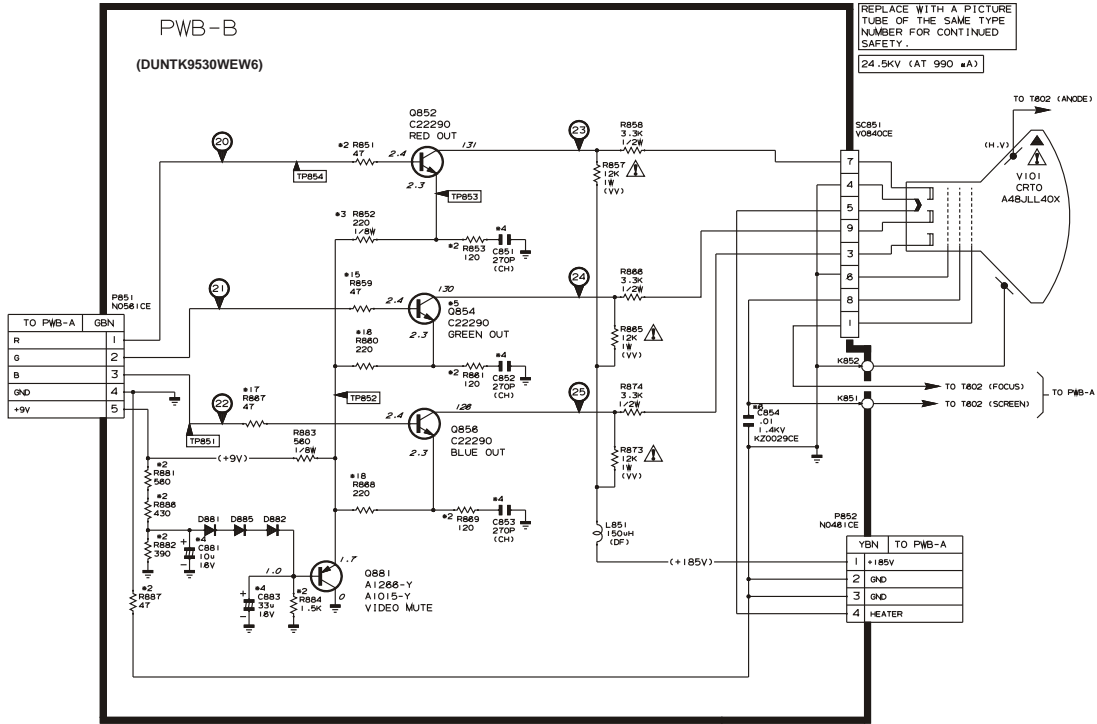

1 2 3 4 5 6

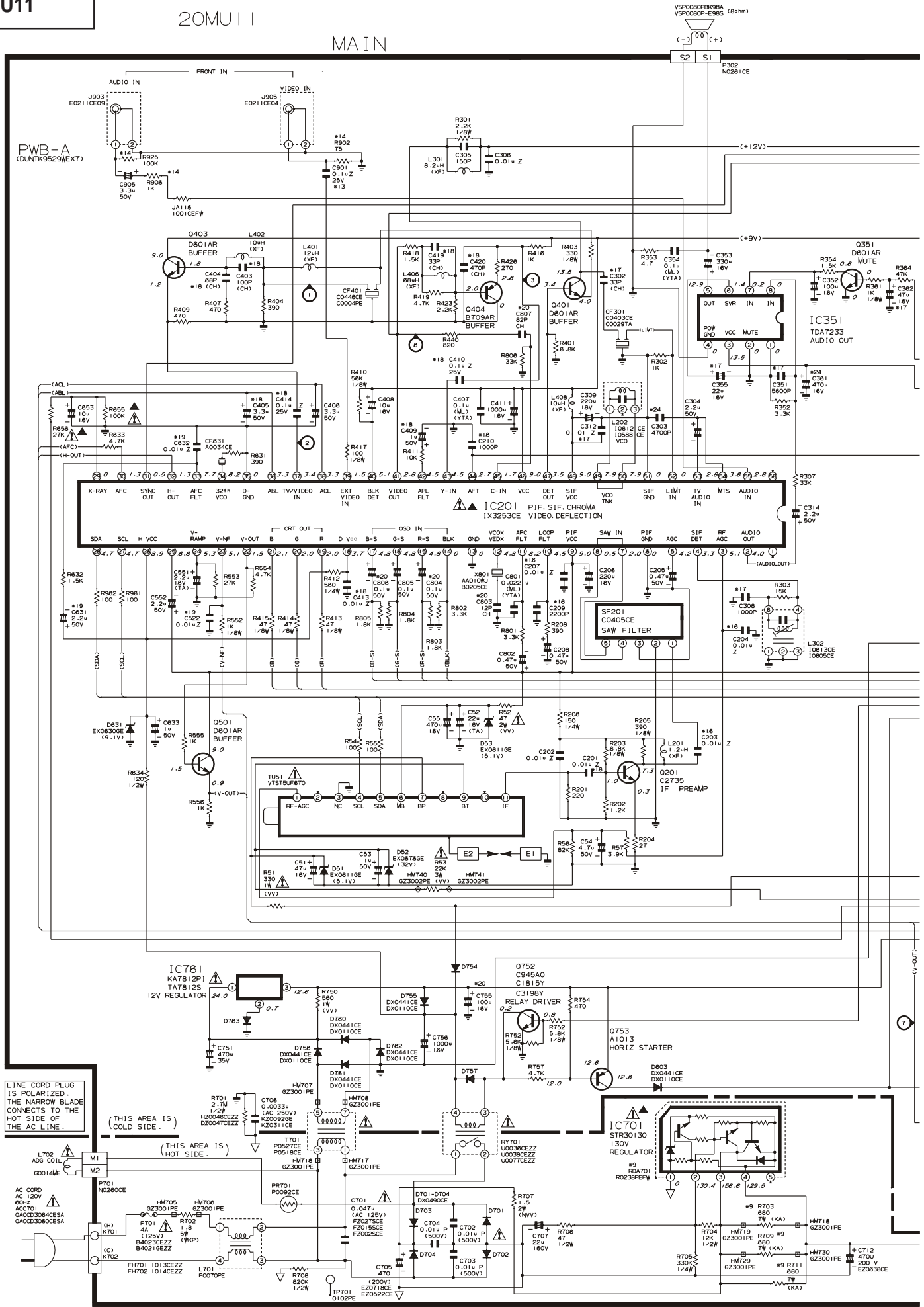

LINE CORD PLUG IS POLARIZED. THE NARROW BLADE CONNECTS TO THE HOT SIDE OF THE AC LINE.

(THIS AREA IS COLD SIDE.)

(THIS AREA IS HOT SIDE.)

NOTE: 1. THE UNIT OF RESISTANCE "OHM" IS OMITTED
 (K=1000 OHMS, M=MEGAOHM).
 2. ALL RESISTORS ARE 1/8 WATT UNLESS OTHERWISE NOTED.
 3. UNIT OF ALL CAPACITORS ARE P WITH PREFIX SYMBOL
 (u, P, ETC.).

AND SHADED () COMPONENTS
 = SAFETY RELATED PARTS.
 ▲ MARK = X-RAY RELATED PARTS.

NOTE: ALL DIODES ARE "1S119" UNLESS OTHERWISE SPECIFIED.
 *ALL TRANSISTORS ARE *2SC2482* OR *2SC3928* UNLESS OTHERWISE SPECIFIED.

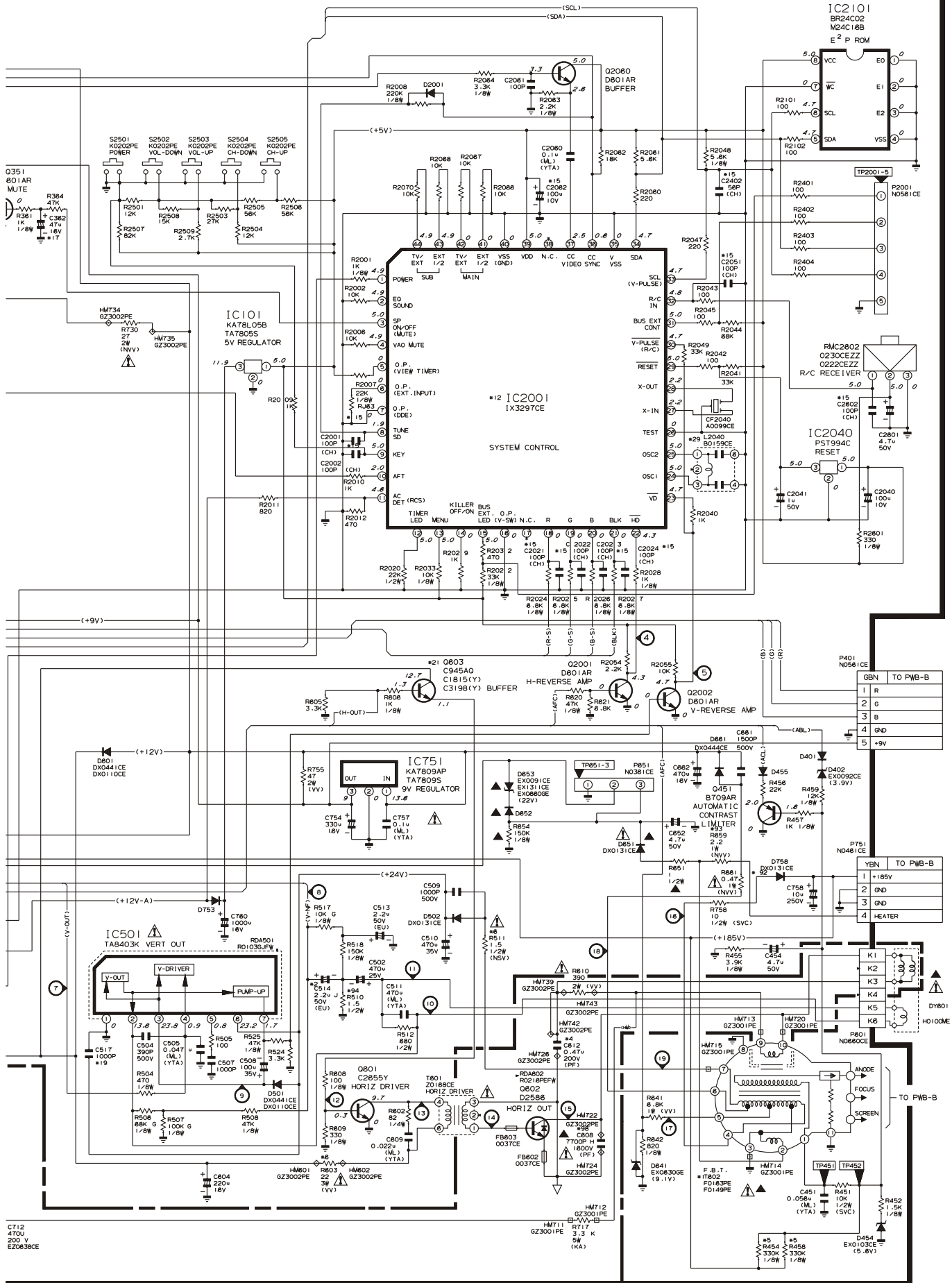

CT12
 470u
 200V
 E20839CE

PWB-A
(DUNTK9532MEXO)

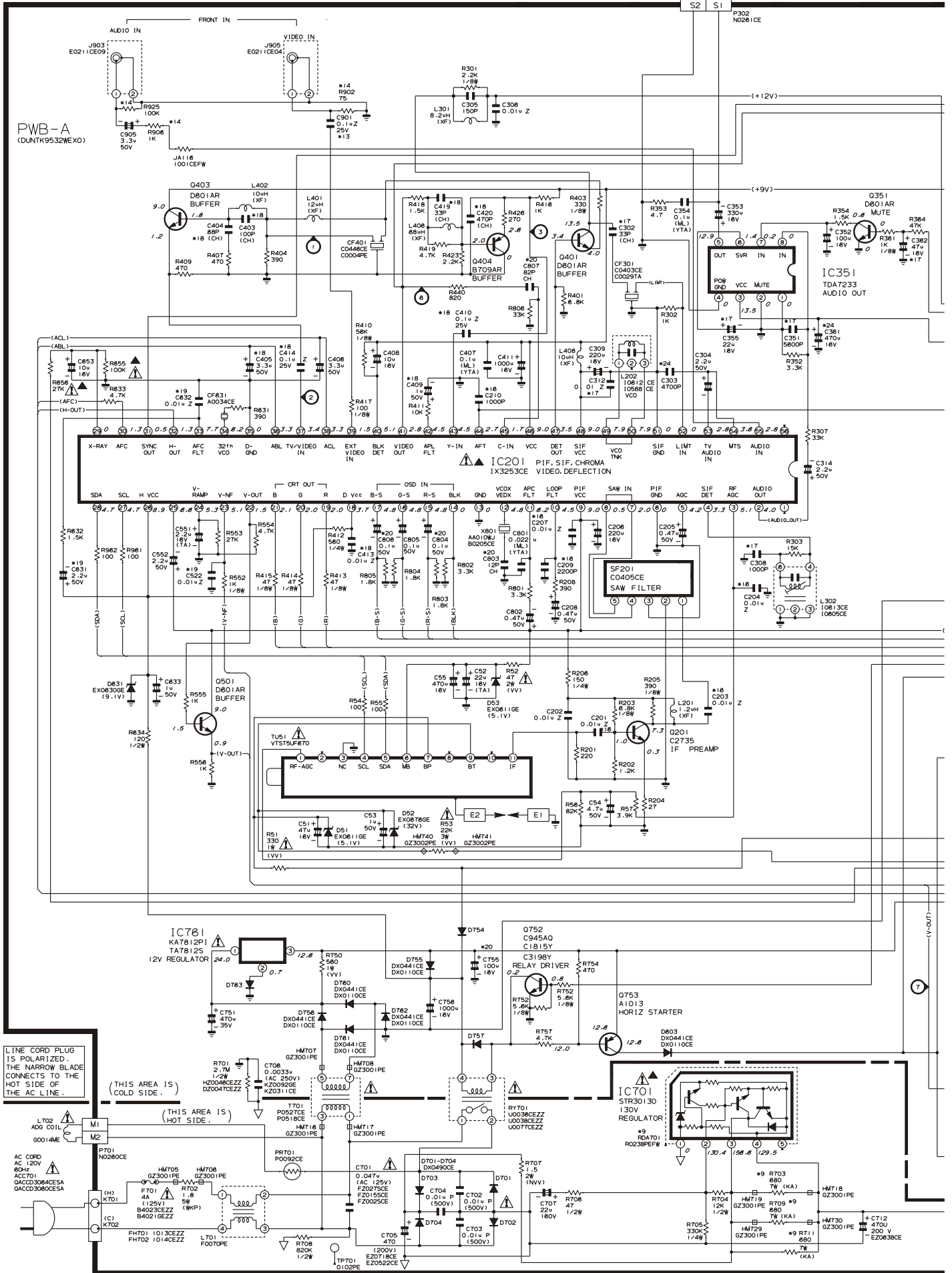

NOTE: 1. THE UNIT OF RESISTANCE "OHM" IS OMITTED
 (K=1000 OHMS, M=10000 OHMS).
 2. ALL RESISTORS ARE 1/8 WATT UNLESS OTHERWISE NOTED.
 3. UNIT OF ALL CAPACITORS ARE F WITH PREFIX SYMBOL
 (u, P, ETC.).

▲ AND SHADED () COMPONENTS
 = SAFETY RELATED PARTS.
 ▲ MARK = X-RAY RELATED PARTS.

NOTE: ALL DIODES ARE "1SS119" UNLESS OTHERWISE SPECIFIED.
 ALL TRANSISTORS ARE "2SC2462" OR "2SC3928" UNLESS OTHERWISE SPECIFIED.

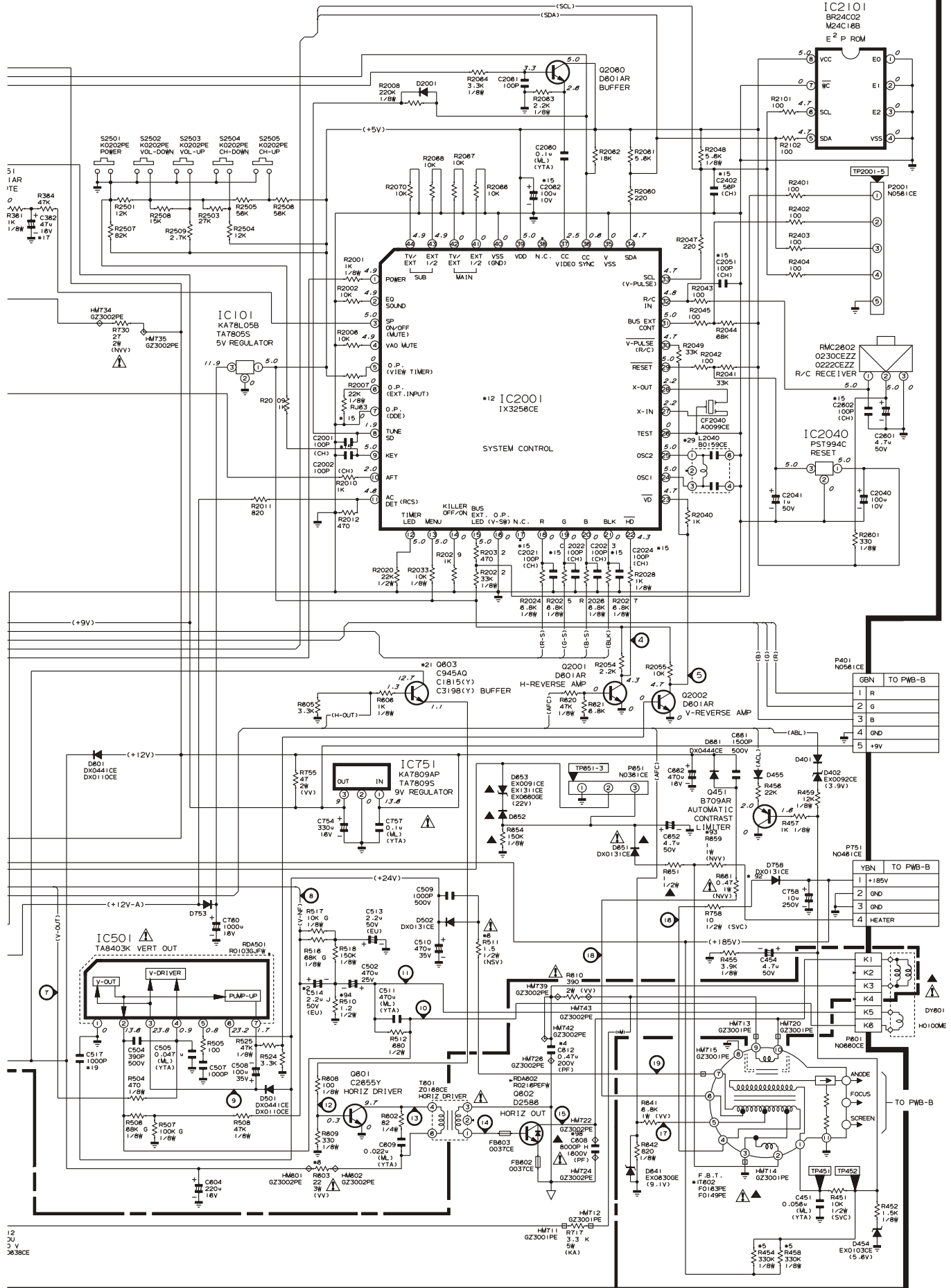

12 3U
 3V
 3638CE

PRINTED WIRING BOARD ASSEMBLIES

■ 20MU11 (DUNTK9529WEX7)

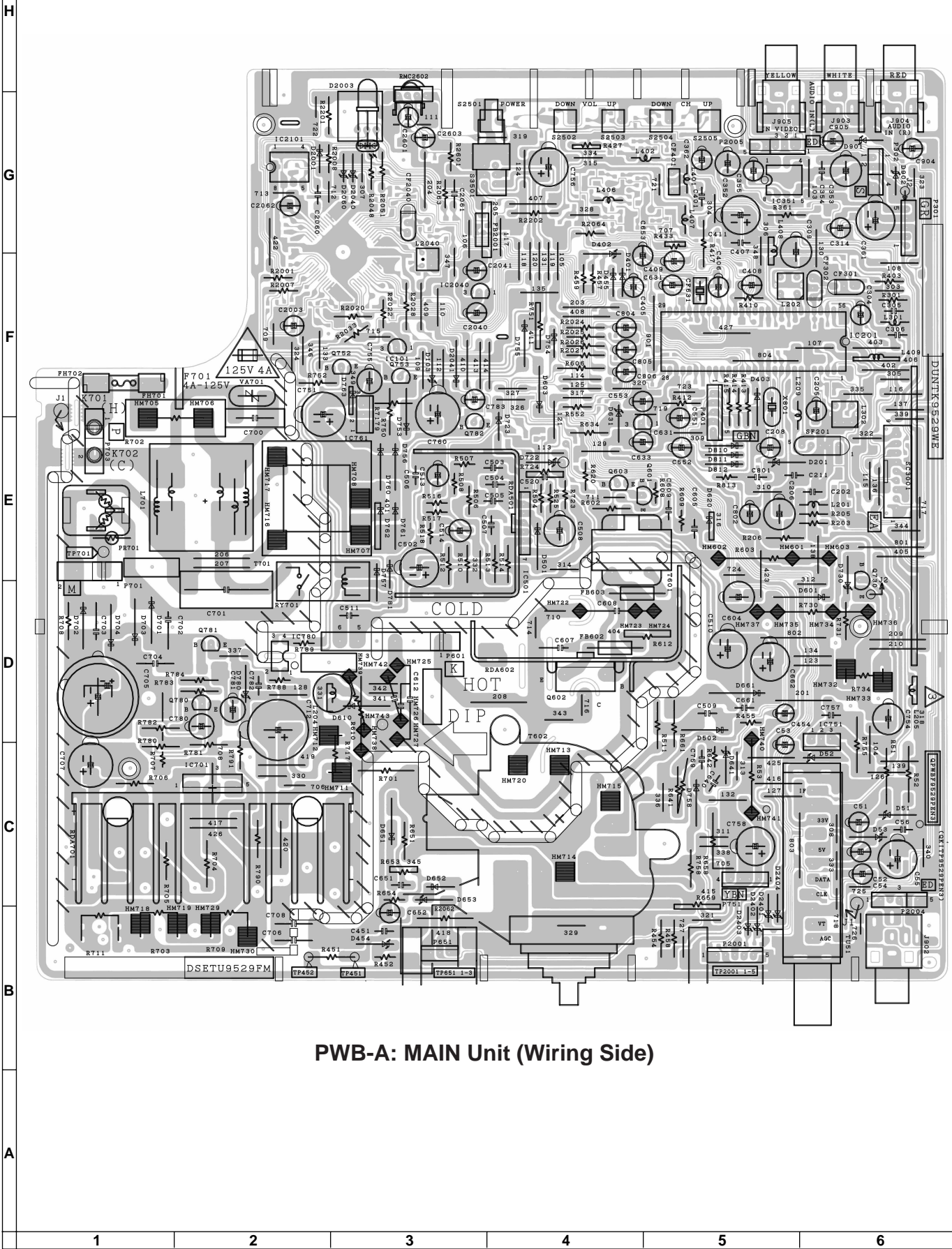

PWB-A: MAIN Unit (Wiring Side)

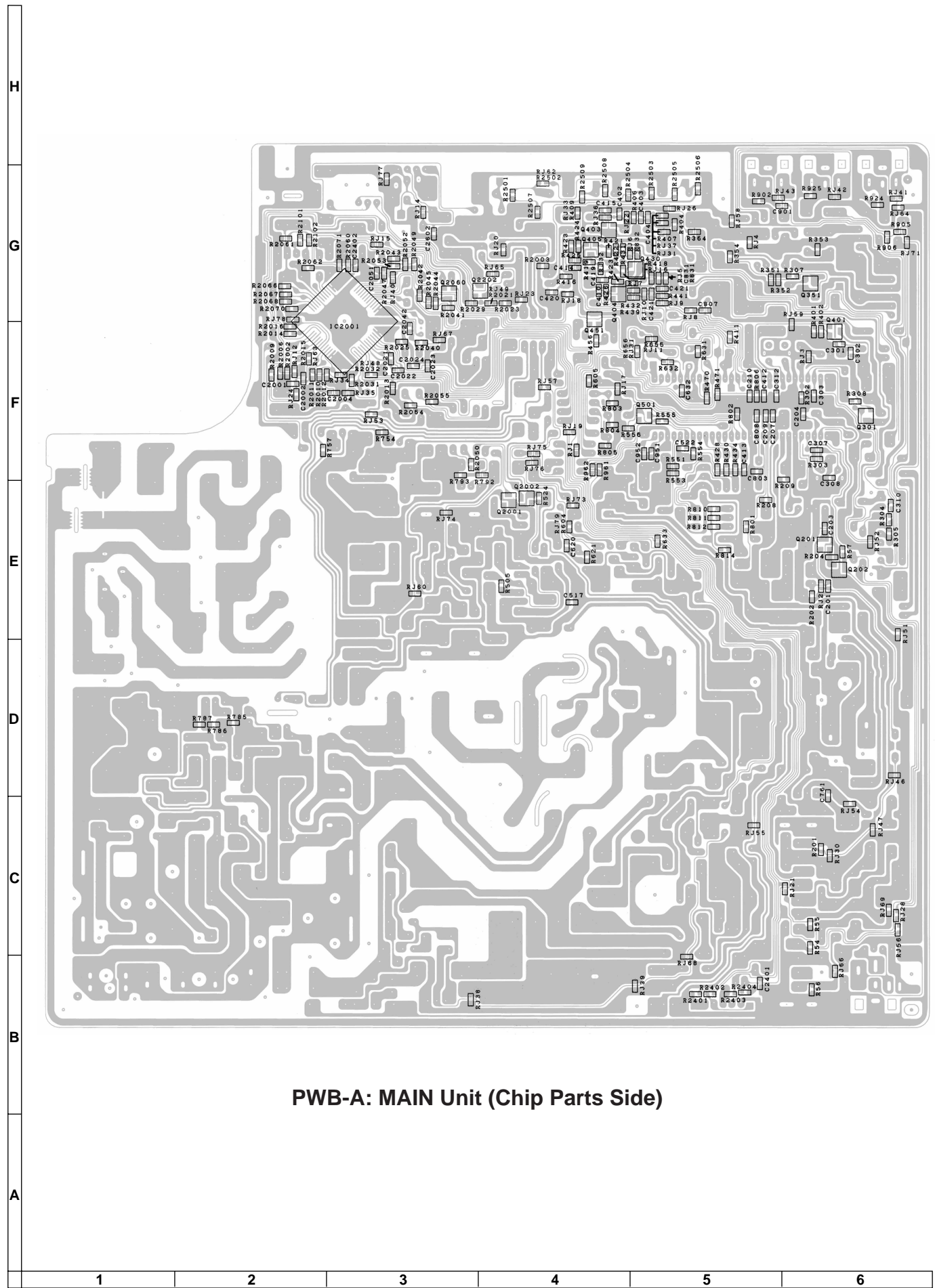

PWB-A: MAIN Unit (Chip Parts Side)

PRINTED WIRING BOARD ASSEMBLIES

■ 20MU11 DUNK9532WEX0

H

G

F

E

D

C

B

A

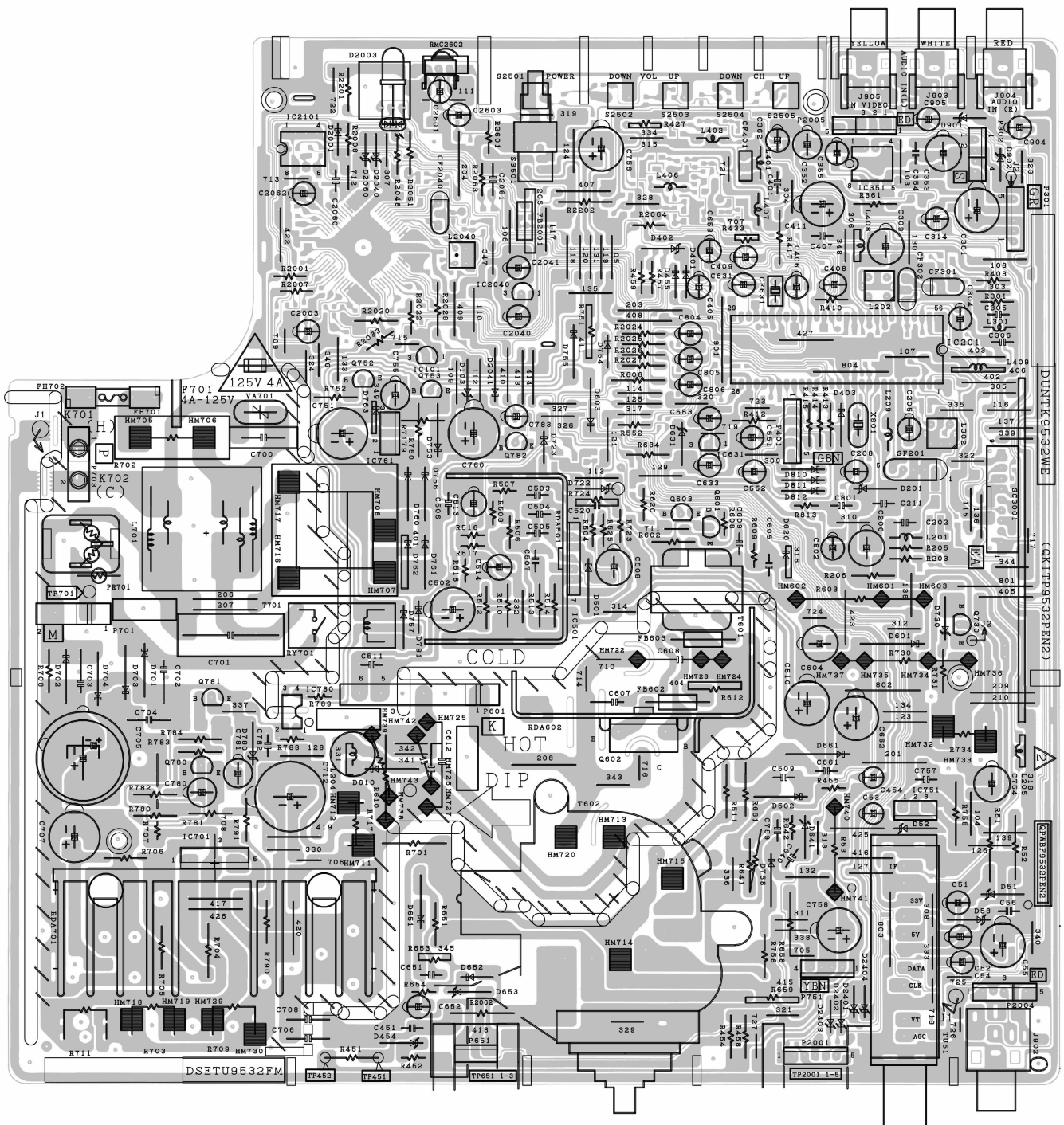

PWB-A: MAIN Unit (Wiring Side)

1

2

3

4

5

6

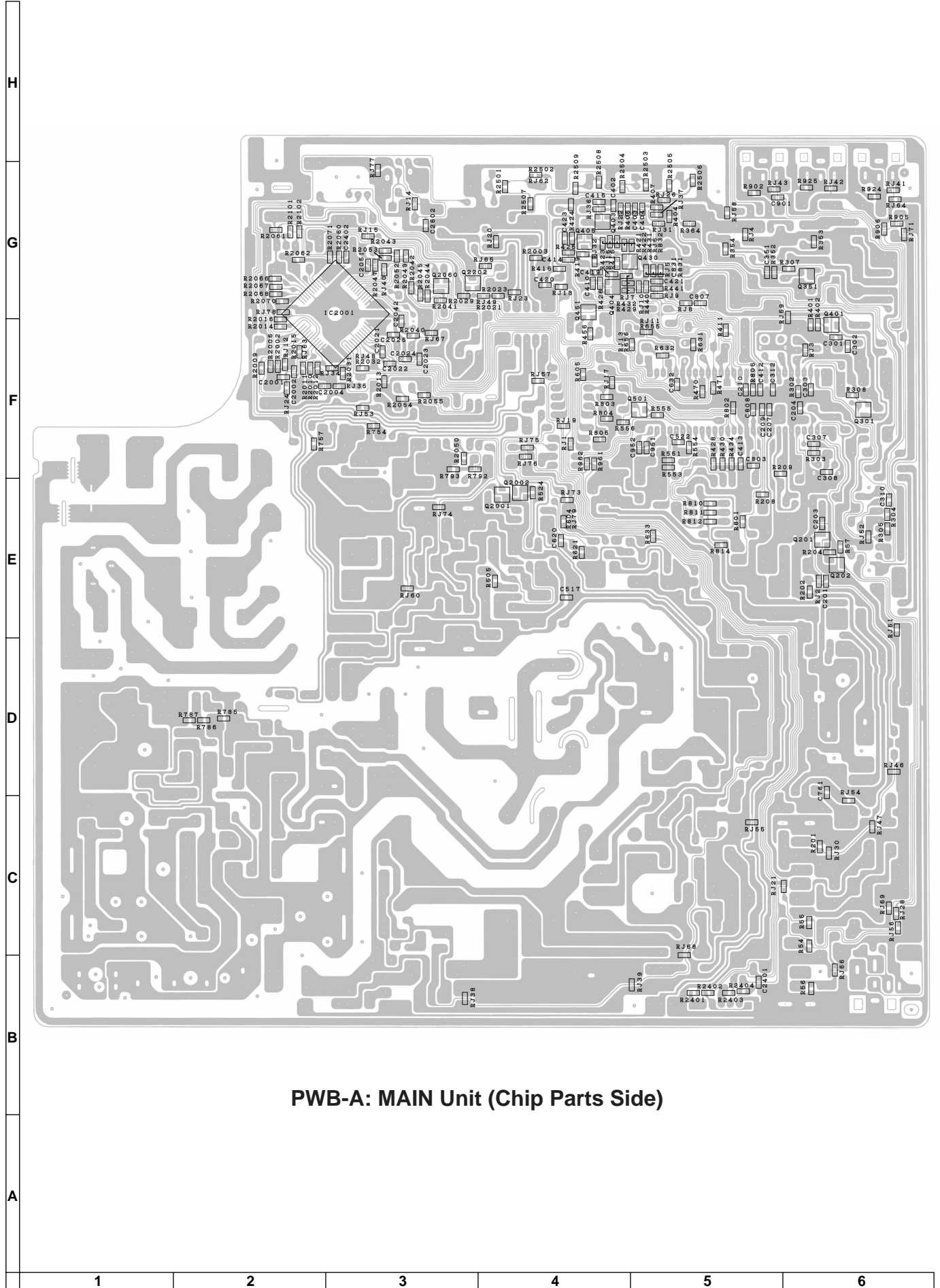

PWB-A: MAIN Unit (Chip Parts Side)

H
G
F
E
D
C
B
A

20MU11 PWB-B: DUNTK9530WEV6

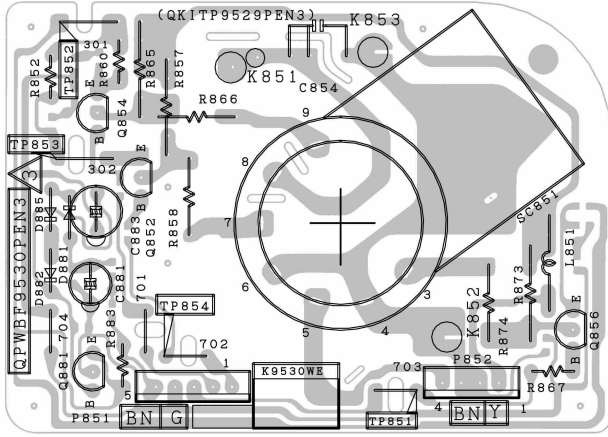

PWB-B: CRT Unit (Wiring Side)

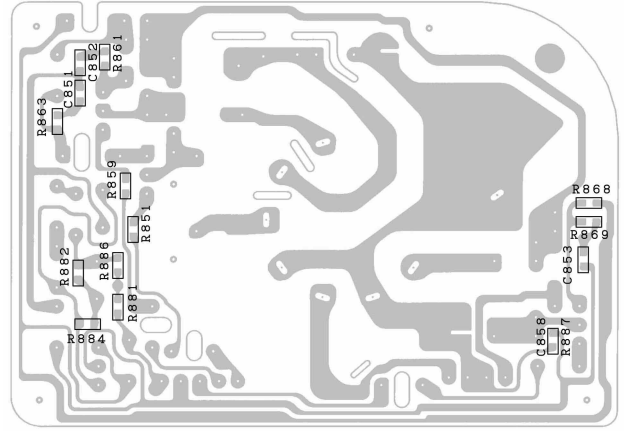

PWB-B: CRT Unit (Chip Parts Side)

20MU11 PWB-B: DUNTK9533WEV4

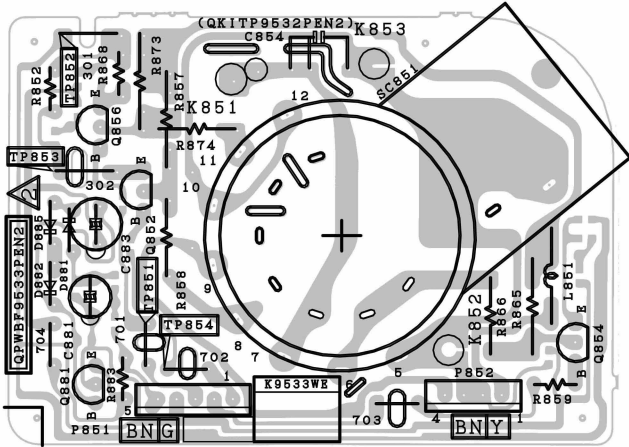

PWB-B: CRT Unit (Wiring Side)

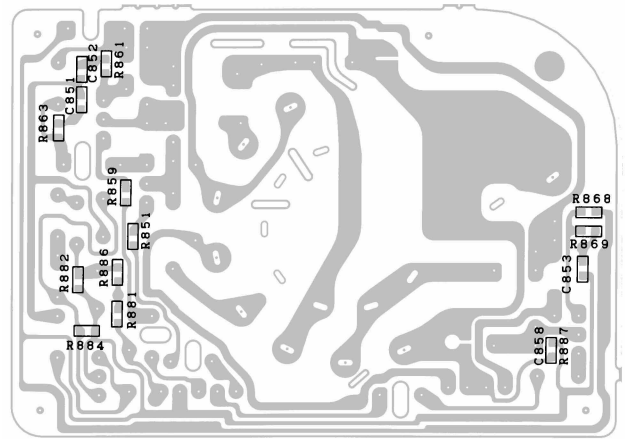

PWB-B: CRT Unit (Chip Parts Side)

1 2 3 4 5 6

PARTS LIST

PARTS REPLACEMENT

Replacement parts which have these special safety characteristics identified in this manual; electrical components having such features are identified by \triangle and shaded areas in the Replacement Parts Lists and Schematic Diagrams. The use of a substitute replacement part which does not have the same safety characteristic as the factory recommended replacement parts shown in this service manual may create shock, fire or other hazards.

"HOW TO ORDER REPLACEMENT PARTS"

To have your order filled promptly and correctly, please furnish the following information.

- | | |
|-----------------|----------------|
| 1. MODEL NUMBER | 2. REF. NO. |
| 3. PART NO. | 4. DESCRIPTION |

in **USA**: Contact your nearest SHARP Parts Distributor to order.
For location of SHARP Parts Distributor, Please call Toll-Free; 1-800-BE-SHARP

★ MARK : SPARE PARTS-DELIVERY SECTION

▲ MARK : X- RAY RELATED PARTS

Ref. No.	Part No.	★	Description	Code	Ref. No.	Part No.	★	Description	Code
PICTURE TUBE					PWB-A: DUNTK9529WEX7 (20MU11)				
20MU11					TUNER				
▲△ V101	VB48JLL40X*S	M	Picture Tube	CC	NOTE: THE PARTS HERE SHOWN ARE SUPPLIED AS AN ASSEMBLY BUT NOT INDEPENDENTLY				
▲△ DY601	RCILH0105GJZZ	M	Deflection Yoke	AY	△ TU51	VTUVTST5UF670	M	Tuner	
△ L702	RCILG0099PEZZ	M	Degaussing Coil		INTEGRATED CIRCUITS				
	PMAGF3045CEZZ	J	Magnet Ass'y	AK	IC101	VHIKA78L05B-1+	J	KA78L05B	AD
	QEARC2016PEZZ	R	Grounding Part		▲△ IC201	RH-iX3253CEZZ	J	TA1268AN	AV
20MU11					IC351	VHiTDA7233/-1	J	TDA7233	AF
▲△ V101	VB48KRD89X/3E	M	Picture Tube		△ IC501	VHiTA8403K/-1	J	TA8403K	AL
▲△ DY601	RCiLH0100MEZZ	M	Deflection Yoke	AZ	▲△ IC701	VHiSTR301301E	J	STR30130	AP
△ L702	RCILG0099PEZZ	M	Degaussing Coil	AM	△ IC751	VHiKA7809AP-1	R	KA7809AP	AE
	MSPRT0002MEZZ	M	Spring for CRT (20MU11)	AA	△ IC761	VHiKA7812Pi-1	R	KA7812PI	AE
	PMAGF3046CEZZ	J	Magnet Ass'y	AK	IC2001	RH-IX3297CEZZ	J	TMPA8701CMF142	AX
	QEARC2016PEZZ	R	Grounding Part		IC2040	VHiPST994C/-1	J	PST994C	AD
PRINTED WIRING BOARD ASSEMBLIES					IC2101	VHiBR24C02/-1	J	BR24C02	AF
(NOT REPLACEMENT ITEM)					TRANSISTORS				
PWB-A DUNTK9529WEX7	- MAIN Unit (20MU11)			—	You can substitute "VS2SC2462-C-1" for "VS2SD601AR/-1".				
PWB-A DUNTK9532WEX0	- MAIN Unit (20MU11)			—	Q201	VS2SC2735//1E	J	2SC2735	AC
PWB-B DUNTK9530WEW6	- CRT Unit (20MU11)			—	Q351	VS2SD601AR/-1	J	2SD601AR	AC
PWB-B DUNTK9533WEV4	- CRT Unit (20MU11,			—	Q401	VS2SD601AR/-1	J	2SD601AR	AC
					Q403	VS2SD601AR/-1	J	2SD601AR	AC
					Q404	VS2SB709AR/-1	J	2SB709AR	AC
					Q451	VS2SB709AR/-1	J	2SB709AR	AC
					Q501	VS2SD601AR/-1	J	2SD601AR	AC
					Q601	VS2SC2655Y/-1	J	2SC2655(Y)	AE
					△ Q602	VS2SD2586//1E	J	2SD2586	AM

Ref. No.	Part No.	★	Description	Code	Ref. No.	Part No.	★	Description	Code
PWB-A: DUNTK9529WEX7 (20MU11)									
MAIN UNIT (Continued)									
Q603	VS2SC945AQ/-1+	J	2SC945	AB	D2001	VHD1SS119//-1	J	Diode	AB
Q752	VS2SC945AQ/-1+	J	2SC945	AB	PACKAGED CIRCUITS				
Q753	VS2SA1013//1E+	J	2SA1013	AD	△ PR701	RMPTP0092CEZZ	J	Packaged Circuit	AF
Q2001	VS2SD601AR/-1+	J	2SD601	AC	X801	RCRCAA010WJZZ	J	Crystal	AF
Q2002	VS2SD601AR/-1	J	2SD601	AC	FILTERS				
Q2060	VS2SD601AR/-1	J	2SD601	AC	CF301	RFILC0403CEZZ	J	Ceramic Filter	AE
					CF401	RFILC0446CEZZ	J	Ceramic Filter	AE
					CF631	RFILA0034CEZZ	J	Ceramic Filter	AD
					CF2040	RFILA0099CEZZ+	J	Ceramic Filter	AD
					SF201	RFILC0405CEZZ	J	SAW Filter	AH
DIODES					COILS				
You can substitute "RH-DX0045GEZZ" or "RH-DX0446GEZZ" for "VHD1SS119//-1".					L201	VP-XF1R2K0000	J	Peaking 1.2μH	AB
D51	RH-EX0611GEZZ	J	Zener Diode, 5.1V	AA	L202	RCiLi0612CEZZ	J	VCO Coil	AE
D52	RH-EX0676GEZZ	J	Zener Diode, 32V	AA	L301	VP-XF8R2K0000	J	Peaking 8.2μH	AB
D53	RH-EX0611GEZZ	J	Zener Diode, 5.1V	AA	L302	RCiLi0613CEZZ	J	IF Coil	AE
D401	VHD1SS119//-1	J	Diode	AB	L401	VP-XF120K0000	J	Peaking 12μH	AB
D402	RH-EX0092CEZZ	J	Zener Diode, 3.9V	AB	L402	VP-XF100K0000	J	Peaking 10μH	AB
D454	RH-EX0103CEZZ	J	Zener Diode, 5.6V	AB	L406	VP-XF680K0000	J	Peaking 68μH	AB
D455	VHD1SS119//-1	J	Diode	AB	L408	VP-XF100K0000	J	Peaking 10μH	AB
D501	RH-DX0441CEZZ	J	Diode	AC	△L701	RCILF0070PEZZ	R	Coil	AH
△ D502	RH-DX0131CEZZ	J	Diode	AC	L2040	RCiLB0159CEZZ	J	Oscillation Coil	AE
D601	RH-DX0441CEZZ	J	Diode	AC	TRANSFORMERS				
D603	RH-DX0441CEZZ	J	Diode	AC	△ T601	RTRNZ0168CEZZ	J	Transformer	AH
D631	RH-EX0630GEZZ	J	Zener Diode, 9.1V	AA	△△ T602	RTRNF0163PEZZ	R	H-Volt Transformer	BE
D641	RH-EX0630GEZZ	J	Zener Diode, 9.1V	AA	△ T701	RTRNP0527CEZZ	J	Power Transformer	AM
△△ D651	RH-DX0131CEZZ	J	Diode	AC	CAPACITORS				
△△ D652	VHD1SS119//-1	J	Diode	AB	<i>[EL... Electrolytic, M-Poly... Metalized Polypro Film]</i>				
△△ D653	RH-EX0091CEZZ	J	Zener Diode, 22V	AB	C51	VCEA0A1CW476M	J	47 16V EL.	AB
△ D661	RH-DX0444CEZZ	J	Diode	AH	C52	VCSATA1CE226K	J	22 16V Tantalum	AD
△ D701	RH-DX0154CEZZ	J	Diode	AC	C53	VCEA0A1HW105M	J	1.0 50V EL.	AB
△ D702	RH-DX0154CEZZ	J	Diode	AC	C54	VCEA0A1HW475M	J	4.7 50V EL.	AB
△ D703	RH-DX0154CEZZ	J	Diode	AC	C55	VCEA0A1CW477M	J	470 16V EL.	AC
△ D704	RH-DX0154CEZZ	J	Diode	AC	C201	VCKYCY1HF103Z	J	0.01 50V Ceramic	AA
D753	VHD1SS119//-1	J	Diode	AB	C202	VCKYPA1HF103Z	J	0.01 50V Ceramic	AA
D754	VHD1SS119//-1	J	Diode	AB	C203	VCKYCY1HF103Z	J	0.01 50V Ceramic	AA
D755	RH-DX0441CEZZ	J	Diode	AC	C204	VCKYCY1HF103Z	J	0.01 50V Ceramic	AA
△ D756	RH-DX0441CEZZ	J	Diode	AC	C205	VCEA0A1HW474M	J	0.47 50V EL.	AB
D757	VHD1SS119//-1	J	Diode	AB	C206	VCEA0A1CW227M	J	220 16V EL.	AC
D758	RH-DX0131CEZZ	J	Diode	AC	C207	VCKYCY1HF103Z	J	0.01 50V Ceramic	AA
△ D760	RH-DX0441CEZZ	J	Diode	AC	C208	VCEA0A1HW474M	J	0.47 50V EL.	AB
△ D761	RH-DX0441CEZZ	J	Diode	AC	C209	VCKYCY1HB222K	J	2200p 50V Ceramic	AA
△ D762	RH-DX0441CEZZ	J	Diode	AC	C210	VCKYCY1HB102K	J	1000p 50V Ceramic	AA
D763	VHD1SS119//-1	J	Diode	AB	C302	VCCCCY1HH330J	J	33p 50V Ceramic	AA
					C303	VCKYCY1HB472K	J	4700p 50V Ceramic	AA
					C304	VCEA0A1HW225M	J	2.2 50V EL.	AB
					C305	VCKYPA1HB151K	J	150p 50V Ceramic	AA
					C306	VCKYPA1HF103Z	J	0.01 50V Ceramic	AA
					C308	VCKYCY1HB102K	J	1000p 50V Ceramic	AA
					C309	VCEA0A1CW227M	J	220 16V EL.	AC
					C312	VCKYCY1HF103Z	J	0.01 50V Ceramic	AA
					C314	VCEA0A1HW225M	J	2.2 50V EL.	AB
					C351	VCKYCY1HB562K	J	5600p 50V Ceramic	AA

Ref. No.	Part No.	★	Description	Code	Ref. No.	Part No.	★	Description	Code
PWB-A: DUNTK9529WEX7 (20MU11)									
MAIN UNIT (Continued)									
C352	VCEA0A1CW107M	J	100 16V EL.	AC	C757	VCQYTA1HM104J+J	0.1	50V Mylar	AB
C353	VCEA0A1CW337M	J	330 16V EL.	AC	△ C758	VCEA0A2EW106M+J	10	250V EL.	AC
C354	RC-QZA104TAYK	J	0.1 50V Mylar	AB	C760	VCEA0A1CW108M+J	1000	16V EL.	AD
C355	VCEA0A1CW226M	J	22 16V EL.	AB	C801	VCQYTA1HM223J+J	0.022	50V Mylar	AB
C361	VCEA0A1CW477M	J	470 16V EL.	AC	C802	VCEA0A1HW474M+J	0.47	50V EL.	AB
C362	VCEA0A1CW476M	J	47 16V EL.	AB	C803	VCCCCY1HH120J*	J	12p 50V Ceramic	AA
C403	VCCCCY1HH101J	J	100p 50V Ceramic	AA	C804	VCEA0A1HW104M	J	0.1 50V EL.	AB
C404	VCCCCY1HH680J	J	68p 50V Ceramic	AA	C805	VCEA0A1HW104M	J	0.1 50V EL.	AB
C405	VCEA0A1HW335M	J	3.3 50V EL.	AB	C806	VCEA0A1HW104M	J	0.1 50V EL.	AB
C406	VCEA0A1HW335M	J	3.3 50V EL.	AB	C807	VCCCCY1HH820J	J	82p 50V Ceramic	AA
C407	RC-QZA104TAYK	J	0.1 50V Mylar	AB	C901	VCKYCY1EF104Z	J	0.1 25V Ceramic	AA
C408	VCEA0A1CW106M	J	10 16V EL.	AB	C905	VCEA0A1HW335M	J	3.3 50V EL.	AB
C409	VCEA0A1HW105M	J	1.0 50V EL.	AB	C2001	VCCCCY1HH101J	J	100p 50V Ceramic	AA
C410	VCKYCY1EF104Z	J	0.1 25V Ceramic	AA	C2002	VCCCCY1HH101J	J	100p 50V Ceramic	AA
C411	VCEAGA1CW108M	J	1000 16V EL.	AD	C2021	VCCCCY1HH101J	J	100p 50V Ceramic	AA
C413	VCKYCY1HF103Z	J	0.01 50V Ceramic	AA	C2022	VCCCCY1HH101J	J	100p 50V Ceramic	AA
C414	VCKYCY1EF104Z	J	0.1 25V Ceramic	AA	C2023	VCCCCY1HH101J	J	100p 50V Ceramic	AA
C419	VCCCCY1HH330J	J	33p 50V Ceramic	AA	C2024	VCCCCY1HH101J	J	100p 50V Ceramic	AA
C420	VCCCCY1HH471J	J	470p 50V Ceramic	AA	C2040	VCEA0A1AW107M	J	100 10V EL.	AB
C451	RC-QZA563TAYK	J	0.056 50V Mylar	AB	C2041	VCEA0A1HW105M	J	1.0 50V EL.	AB
C454	VCEA0A1HW475M	J	4.7 50V EL.	AB	C2051	VCCCCY1HH101J	J	100p 50V Ceramic	AA
C502	VCEA0A1EW477M	J	470 25V EL.	AD	C2060	RC-QZA104TAYK	J	0.1 50V Mylar	AB
C504	VCKYPA2HB391K	J	390p 500V Ceramic	AA	C2061	VCKYD41HB101K	J	100p 50V Ceramic	AA
C505	VCQYTA1HM473K	J	0.047 50V Mylar	AB	C2062	VCEA0A1AW107M	J	100 10V EL.	AB
C507	VCKYPA1HB102K	J	1000p 50V Ceramic	AA	C2402	VCCCCY1HH560J	J	56p 50V Ceramic	AA
C508	VCEAGA1VW107M	J	100 35V EL.	AC	C2601	VCEA0A1HW475M	J	4.7 50V EL.	AB
C509	VCKYPA2HB102K	J	1000p 500V Ceramic	AA	C2602	VCCCCY1HH101J	J	100p 50V Ceramic	AA
C510	VCEAGA1VW477M	J	470 35V EL.	AD	RESISTORS				
C511	VCQYTA1HM473K	J	0.047 50V Mylar	AB	<i>[M-Ox... Metal Oxide, M-Film ... Metal Film]</i>				
C513	VCEACA1HC225M	J	2.2 50V EL.	AC	RJ1	VRS-CY1JF000J	J	0 1/16W M-Ox.	AA
C514	VCEACA1HC225J	J	2.2 50V EL.	AC	RJ3	VRS-CY1JF000J	J	0 1/16W M-Ox.	AA
C517	VCKYCY1HB102K	J	1000p 50V Ceramic	AA	RJ5	VRS-CY1JF000J	J	0 1/16W M-Ox.	AA
C522	VCKYCY1HF103Z	J	0.01 50V Ceramic	AA	RJ6	VRS-CY1JF000J	J	0 1/16W M-Ox.	AA
C551	VCSATA1CE225K	J	2.2 16V Tantalum	AB	RJ7	VRS-CY1JF000J	J	0 1/16W M-Ox.	AA
C552	VCEA0A1HW225M	J	2.2 50V EL.	AB	RJ9	VRS-CY1JF000J	J	0 1/16W M-Ox.	AA
C604	VCEA0A1CW227M	J	220 16V EL.	AC	RJ10	VRS-CY1JF000J	J	0 1/16W M-Ox.	AA
△△ C608	VCFPD3CA772H	J	7700p 1.6kV M-Poly.	AF	RJ15	VRS-CY1JF000J	J	0 1/16W M-Ox.	AA
C609	RC-QZA223TAYK	J	0.022 50V Mylar	AB	RJ17	VRS-CY1JF000J	J	0 1/16W M-Ox.	AA
C612	VCFPD2EB474J	J	0.47 250V M-Poly.	AF	RJ18	VRS-CY1JF000J	J	0 1/16W M-Ox.	AA
C631	VCEA0A1HW225M	J	2.2 50V EL.	AB	RJ19	VRS-CY1JF000J	J	0 1/16W M-Ox.	AA
C632	VCKYCY1HF103Z	J	0.01 50V Ceramic	AA	RJ20	VRS-CY1JF000J	J	0 1/16W M-Ox.	AA
C633	VCEA0A1HW105M	J	1.0 50V EL.	AB	RJ21	VRS-CY1JF000J	J	0 1/16W M-Ox.	AA
C652	VCEA0A1HW475M	J	4.7 50V EL.	AB	RJ23	VRS-CY1JF000J	J	0 1/16W M-Ox.	AA
C653	VCEA0A1CW106M	J	10 16V EL.	AB	RJ24	VRS-CY1JF000J	J	0 1/16W M-Ox.	AA
C661	VCKYPA2HB152K	J	1500p 500V Ceramic	AA	RJ26	VRS-CY1JF000J	J	0 1/16W M-Ox.	AA
C662	VCEA0A1CW477M	J	470 16V EL.	AC	RJ31	VRS-CY1JF000J	J	0 1/16W M-Ox.	AA
△ C701	RC-FZ027SCEZZ	J	0.047 AC125V Plastic		RJ32	VRS-CY1JF000J	J	0 1/16W M-Ox.	AA
C702	VCKYPB2HE103P	J	0.01 500V Ceramic	AB	RJ35	VRS-CY1JF000J	J	0 1/16W M-Ox.	AA
C703	VCKYPB2HE103P	J	0.01 500V Ceramic	AB	RJ39	VRS-CY1JF000J	J	0 1/16W M-Ox.	AA
C704	VCKYPB2HE103P	J	0.01 500V Ceramic	AB	RJ40	VRS-CY1JF000J	J	0 1/16W M-Ox.	AA
△ C705	RC-EZ0718CEZZ	J	470 200V EL.		RJ46	VRS-CY1JF000J	J	0 1/16W M-Ox.	AA
△ C706	RC-KZ0092GEZZ	J	3300p AC125V Ceramic	AC	RJ49	VRS-CY1JF000J	J	0 1/16W M-Ox.	AA
C707	VCEAGA2CW226M	J	22 160V EL.	AD	RJ52	VRS-CY1JF000J	J	0 1/16W M-Ox.	AA
△ C712	RC-EZ0638CEZZ	J	33 160V EL.	AG	RJ54	VRS-CY1JF000J	J	0 1/16W M-Ox.	AA
C751	VCEA0A1VW477M	J	470 35V EL.	AB	RJ55	VRS-CY1JF000J	J	0 1/16W M-Ox.	AA
C754	VCEA0A1CW337M	J	330 16V EL.	AC	RJ57	VRS-CY1JF000J	J	0 1/16W M-Ox.	AA
C755	VCEA0A1CW107M	J	100 16V EL.	AC	RJ59	VRS-CY1JF000J	J	0 1/16W M-Ox.	AA
C756	VCEAGA1CW108M	J	1000 16V EL.	AD	RJ62	VRS-CY1JF000J	J	0 1/16W M-Ox.	AA
					RJ63	VRS-CY1JF000J	J	0 1/16W M-Ox.	AA
					RJ66	VRS-CY1JF000J	J	0 1/16W M-Ox.	AA
					RJ67	VRS-CY1JF000J	J	0 1/16W M-Ox.	AA
					RJ68	VRS-CY1JF000J	J	0 1/16W M-Ox.	AA
					RJ69	VRS-CY1JF000J	J	0 1/16W M-Ox.	AA
					RJ71	VRS-CY1JF000J	J	0 1/16W M-Ox.	AA
					RJ75	VRS-CY1JF000J	J	0 1/16W M-Ox.	AA
					RJ77	VRS-CY1JF000J	J	0 1/16W M-Ox.	AA
					RJ78	VRS-CY1JF000J	J	0 1/16W M-Ox.	AA
					RJ79	VRS-CY1JF000J	J	0 1/16W M-Ox.	AA
					△ R51	VRS-VV3AB331J	J	330 1W M-Ox.	AA
					△ R52	VRS-VV3DB470J	J	47 2W M-Ox.	AA
					△ R53	VRS-VV3LB223J	J	22k 3.0W M-Ox.	AB
					R54	VRS-CY1JF101J	J	100 1/16W M-Ox.	AA
					R55	VRS-CY1JF101J	J	100 1/16W M-Ox.	AA
					R56	VRS-CY1JF823J	J	82k 1/16W M-Ox.	AA
					R57	VRS-CY1JF392J	J	3.9k 1/16W M-Ox.	AA

Ref. No.	Part No.	★	Description	Code	Ref. No.	Part No.	★	Description	Code
PWB-A: DUNTK9529WEX7 (20MU11)									
MAIN UNIT (Continued)									
R201	VRS-CY1JF221J	J	220 1/16W	M-Ox. AA	R634	VRD-RM2HD121J	J	120 1/2W	Carbon AA
R202	VRS-CY1JF122J	J	1.2k 1/16W	M-Ox. AA	△ R641	VRS-VV3AB682J	J	6.8k 1W	M-Ox. AA
R203	VRD-RA2BE682J	J	6.8k 1/8W	Carbon AA	R642	VRD-RA2BE821J	J	820 1/8W	Carbon AA
R204	VRS-CY1JF270J	J	27 1/16W	M-Ox. AA	▲ R651	VRD-RM2HD1R0J	J	1.0 1/2W	Carbon AA
R205	VRD-RA2BE391J	J	390 1/8W	Carbon AA	▲ R654	VRD-RA2BE154J	J	150k 1/8W	Carbon AA
R206	VRD-RA2EE151J	J	150 1/4W	Carbon AA	▲ R655	VRS-CY1JF104J	J	100k 1/16W	M-Ox. AA
R208	VRS-CY1JF391J	J	390 1/16W	M-Ox. AA	▲ R656	VRS-CY1JF273J	J	27k 1/16W	M-Ox. AA
R301	VRD-RA2BE222J	J	2.2k 1/8W	Carbon AA	△ R659	VRN-VV3AB2R2J	J	2.2 1W	M-Film AA
R302	VRS-CY1JF102J	J	1.0k 1/16W	M-Ox. AA	△ R661	VRN-VV3ABR47J	J	0.47 1W	M-Film AA
R303	VRS-CY1JF153J	J	15k 1/16W	M-Ox. AA	△ R701	RR-HZ0046CEZZ	J	2.7M 1/2W	Solid AD
R307	VRS-CY1JF333J	J	33k 1/16W	M-Ox. AA		or			
R352	VRS-CY1JF320J	J	3.3k 1/16W	M-Ox. AA		RH-DZ0047CEZZ			
R353	VRS-CY1JF4R7J	J	4.7 1/16W	M-Ox. AA		or			
R354	VRS-CY1JF152J	J	1.5k 1/16W	M-Ox. AA		VRC-UB2HG275K			
R361	VRD-RA2BE102J	J	1.0k 1/8W	Carbon AA	△ R702	VRW-KP3HC1R8K	J	1.8 5W	Cement AC
R364	VRS-CY1JF473J	J	47k 1/16W	M-Ox. AA	△ R703	VRS-KA3NG681J	J	680 7.0W	M-Ox. AF
R401	VRS-CY1JF682J	J	6.8k 1/16W	M-Ox. AA	△ R704	VRD-RM2HD123J	J	12k 1/2W	Carbon AA
R403	VRD-RA2BE331J	J	330 1/8W	Carbon AA	R705	VRD-RA2EE334J	J	330k 1/4W	Carbon AA
R404	VRS-CY1JF391J	J	390 1/16W	M-Ox. AA	R706	VRD-RM2HD470J	J	47 1/2W	Carbon AA
R407	VRS-CY1JF471J	J	470 1/16W	M-Ox. AA	△ R707	VRN-VV3DB1R5J	J	1.5 2W	M-Film AB
R409	VRS-CY1JF471J	J	470 1/16W	M-Ox. AA	△ R708	VRD-RM2HD824J	J	820k 1/2W	Carbon AA
R410	VRD-RA2BE563J	J	56k 1/8W	Carbon AA	△ R709	VRS-KA3NG681J	J	680 7.0W	M-Ox. AF
R411	VRS-CY1JF103J	J	10k 1/16W	M-Ox. AA	△ R711	VRS-KA3NG681J	J	680 7.0W	M-Ox. AF
R412	VRD-RA2EE561J	J	560 1/4W	Carbon AA	△ R717	VRS-KA3HG3R3K	J	3.3 5W	M-Ox. AD
R413	VRD-RA2BE470J	J	47 1/8W	Carbon AA	△ R730	VRN-VV3DB270J	J	27 2W	M-Ox. AA
R414	VRD-RA2BE470J	J	47 1/8W	Carbon AA	△ R750	VRS-VV3AB561J	J	560 1W	M-Ox. AA
R415	VRD-RA2BE470J	J	47 1/8W	Carbon AA	R752	VRD-RA2BE562J	J	5.6k 1/8W	Carbon AA
R416	VRS-CY1JF102J	J	1.0k 1/16W	M-Ox. AA	R754	VRS-CY1JF471J	J	470 1/16W	M-Ox. AA
R417	VRD-RA2BE101J	J	100 1/8W	Carbon AB	△ R755	VRS-VV3DB470J	J	47 2W	M-Ox. AA
R418	VRS-CY1JF152J	J	1.5k 1/16W	M-Ox. AA	R757	VRS-CY1JF472J	J	4.7k 1/16W	M-Ox. AA
R419	VRS-CY1JF472J	J	4.7k 1/16W	M-Ox. AA	△ R758	VRS-SV2HC100J	J	10 1/2W	M-Ox. AA
R423	VRS-CY1JF222J	J	2.2k 1/16W	M-Ox. AA	R801	VRS-CY1JF332J	J	3.3k 1/16W	M-Ox. AA
R426	VRS-CY1JF271J	J	270 1/16W	M-Ox. AA	R802	VRS-CY1JF332J	J	3.3k 1/16W	M-Ox. AA
R440	VRS-CY1JF821J	J	820 1/16W	M-Ox. AA	R803	VRS-CY1JF182J	J	1.8k 1/16W	M-Ox. AA
△ R451	VRS-SV2HC103J	J	10k 1/2W	M-Ox. AA	R804	VRS-CY1JF182J	J	1.8k 1/16W	M-Ox. AA
R452	VRD-RA2BE152J	J	1.5k 1/8W	Carbon AA	R805	VRS-CY1JF182J	J	1.8k 1/16W	M-Ox. AA
R454	VRD-RA2BE334J	J	330k 1/8W	Carbon AA	R806	VRS-CY1JF333J	J	33k 1/16W	M-Ox. AA
R455	VRD-RA2BE392J	J	3.9k 1/8W	Carbon AA	R902	VRS-CY1JF750J	J	75 1/16W	M-Ox. AA
R456	VRS-CY1JF223J	J	22k 1/16W	M-Ox. AA	R906	VRS-CY1JF102J	J	1.0k 1/16W	M-Ox. AA
R457	VRD-RA2BE102J	J	1.0k 1/8W	Carbon AA	R925	VRS-CY1JF104J	J	100k 1/16W	M-Ox. AA
R458	VRD-RA2BE334J	J	330k 1/8W	Carbon AA	R961	VRS-CY1JF101J	J	100 1/16W	M-Ox. AA
R459	VRD-RA2BE123J	J	12k 1/8W	Carbon AA	R962	VRS-CY1JF101J	J	100 1/16W	M-Ox. AA
R504	VRD-RA2BE471J	J	470 1/8W	Carbon AA	R2001	VRD-RA2BE102J	J	1.0k 1/8W	Carbon AA
R505	VRS-CY1JF101J	J	100 1/16W	M-Ox. AA	R2002	VRS-CY1JF103J	J	10k 1/16W	M-Ox. AA
R506	VRD-RA2BE683G	J	68k 1/8W	Carbon AA	R2006	VRS-CY1JF103J	J	10k 1/16W	M-Ox. AA
R507	VRD-RA2BE104G	J	100k 1/8W	Carbon AA	R2007	VRD-RA2BE223J	J	22k 1/8W	Carbon AA
R508	VRD-RA2BE473J	J	47k 1/8W	Carbon AA	R2008	VRD-RA2BE224J	J	220k 1/8W	Carbon AA
R510	VRD-RM2HD1R5J	J	1.5 1/2W	Carbon AA	R2009	VRS-CY1JF102J	J	1.0k 1/16W	M-Ox. AA
△ R511	VRN-SV2HB1R5J	J	1.5 1/2W	M-Film AB	R2010	VRS-CY1JF102J	J	1.0k 1/16W	M-Ox. AA
R512	VRD-RM2HD681J	J	680 1/2W	Carbon AA	R2011	VRS-CY1JF821J	J	820 1/16W	M-Ox. AA
R516	VRD-RA2BE683G	J	68k 1/8W	Carbon AA	R2012	VRS-CY1JF471J	J	470 1/16W	M-Ox. AA
R517	VRD-RA2BE103G	J	10k 1/8W	Carbon AA	R2020	VRD-RM2HD223J	J	22k 1/2W	Carbon AA
R518	VRD-RA2BE154J	J	150k 1/8W	Carbon AA	R2022	VRD-RA2BE333J	J	33k 1/8W	Carbon AA
R524	VRS-CY1JF332J	J	3.3k 1/16W	M-Ox. AA	R2024	VRD-RA2BE682J	J	6.8k 1/8W	Carbon AA
R525	VRD-RA2BE473J	J	47k 1/8W	Carbon AA	R2025	VRD-RA2BE682J	J	6.8k 1/8W	Carbon AA
R552	VRD-RA2BE102J	J	1.0k 1/8W	Carbon AA	R2026	VRD-RA2BE682J	J	6.8k 1/8W	Carbon AA
R553	VRS-CY1JF273J	J	27k 1/16W	M-Ox. AA	R2027	VRD-RA2BE682J	J	6.8k 1/8W	Carbon AA
R554	VRS-CY1JF472J	J	4.7k 1/16W	M-Ox. AA	R2028	VRD-RA2BE102J	J	1.0k 1/8W	Carbon AA
R555	VRS-CY1JF102J	J	1.0k 1/16W	M-Ox. AA	R2029	VRS-CY1JF102J	J	1.0k 1/16W	M-Ox. AA
R556	VRS-CY1JF102J	J	1.0k 1/16W	M-Ox. AA	R2032	VRS-CY1JF471J	J	470 1/16W	M-Ox. AA
R602	VRD-RA2EE820J	J	82 1/4W	Carbon AA	R2033	VRD-RA2BE103J	J	10k 1/8W	Carbon AA
△ R603	VRS-VV3LB220J	J	22 3.0W	M-Ox. AB	R2040	VRS-CY1JF102J	J	1.0k 1/16W	M-Ox. AA
R605	VRS-CY1JF332J	J	3.3k 1/16W	M-Ox. AA	R2041	VRS-CY1JF333J	J	33k 1/16W	M-Ox. AA
R606	VRD-RA2BE102J	J	1.0k 1/8W	Carbon AA	R2042	VRS-CY1JF101J	J	100 1/16W	M-Ox. AA
R608	VRD-RA2BE101J	J	100 1/8W	Carbon AB	R2043	VRS-CY1JF101J	J	100 1/16W	M-Ox. AA
R609	VRD-RA2BE331J	J	330 1/8W	Carbon AA	R2044	VRS-CY1JF683J	J	68k 1/16W	M-Ox. AA
△ R610	VRS-VV3DB391J	J	390 2W	M-Ox. AA	R2045	VRS-CY1JF101J	J	100 1/16W	M-Ox. AA
R620	VRD-RA2BE473J	J	47k 1/8W	Carbon AA	R2047	VRS-CY1JF221J	J	220 1/16W	M-Ox. AA
R621	VRS-CY1JF682J	J	6.8k 1/16W	M-Ox. AA	R2048	VRD-RA2BE562J	J	5.6k 1/8W	Carbon AA
R631	VRS-CY1JF391J	J	390 1/16W	M-Ox. AA	R2049	VRS-CY1JF333J	J	33k 1/16W	M-Ox. AA
R632	VRS-CY1JF152J	J	1.5k 1/16W	M-Ox. AA	R2054	VRS-CY1JF222J	J	2.2k 1/16W	M-Ox. AA
R633	VRS-CY1JF472J	J	4.7k 1/16W	M-Ox. AA	R2055	VRS-CY1JF103J	J	10k 1/16W	M-Ox. AA
					R2060	VRS-CY1JF221J	J	220 1/16W	M-Ox. AA
					R2061	VRS-CY1JF562J	J	5.6k 1/16W	M-Ox. AA
					R2062	VRS-CY1JF183J	J	18k 1/16W	M-Ox. AA
					R2063	VRD-RA2BE222J	J	2.2k 1/8W	Carbon AA

Ref. No.	Part No.	★	Description	Code	Ref. No.	Part No.	★	Description	Code
PWB-A: DUNTK9529WEX7 (20MU11)					HM718 LX-GZ3001PEZZ R Screw AB				
MAIN UNIT (Continued)					HM719 LX-GZ3001PEZZ R Screw AB				
R2064	VRD-RA2BE332J	J	3.3k 1/8W Carbon	AA	HM720 LX-GZ3001PEZZ	R	Screw	AB	
R2066	VRS-CY1JF103J	J	10k 1/16W M-Ox.	AA	HM722 LX-GZ3002PEZZ	R	Screw	AB	
R2067	VRS-CY1JF103J	J	10k 1/16W M-Ox.	AA	HM724 LX-GZ3002PEZZ	R	Screw	AB	
R2068	VRS-CY1JF103J	J	10k 1/16W M-Ox.	AA	HM726 LX-GZ3002PEZZ	R	Screw	AB	
R2070	VRS-CY1JF103J	J	10k 1/16W M-Ox.	AA	HM729 LX-GZ3001PEZZ	R	Screw	AB	
R2101	VRS-CY1JF101J	J	100 1/16W M-Ox.	AA	HM730 LX-GZ3001PEZZ	R	Screw	AB	
R2102	VRS-CY1JF101J	J	100 1/16W M-Ox.	AA	HM734 LX-GZ3002PEZZ	R	Screw	AB	
R2401	VRS-CY1JF101J	J	100 1/16W M-Ox.	AA	HM735 LX-GZ3002PEZZ	R	Screw	AB	
R2402	VRS-CY1JF101J	J	100 1/16W M-Ox.	AA	HM739 LX-GZ3002PEZZ	R	Screw	AB	
R2403	VRS-CY1JF101J	J	100 1/16W M-Ox.	AA	HM740 LX-GZ3002PEZZ	R	Screw	AB	
R2404	VRS-CY1JF101J	J	100 1/16W M-Ox.	AA	HM741 LX-GZ3002PEZZ	R	Screw	AB	
R2501	VRS-CY1JF123J	J	12k 1/16W M-Ox.	AA	HM742 LX-GZ3002PEZZ	R	Screw	AB	
R2503	VRS-CY1JF273J	J	27k 1/16W M-Ox.	AA	HM743 LX-GZ3002PEZZ	R	Screw	AB	
R2504	VRS-CY1JF123J	J	12k 1/16W M-Ox.	AA	RDA501 PRDAR0103GJFW	X	Heat Sink, for IC501	AN	
R2505	VRS-CY1JF563J	J	56k 1/16W M-Ox.	AA	RDA602 PRDAR0216PEFW	R	Heat Sink, for Q602	AE	
R2506	VRS-CY1JF563J	J	56k 1/16W M-Ox.	AA	RDA701 PRDAR0238PEFW	R	Heat Sink, for IC701	AN	
R2507	VRS-CY1JF823J	J	82k 1/16W M-Ox.	AA	TP701 QLUGP0102PEZZ	R	Lug	AA	
R2508	VRS-CY1JF153J	J	15k 1/16W M-Ox.	AA	PZETM0016CEZZ	J	Insulator	AB	
R2509	VRS-CY1JF272J	J	2.7k 1/16W M-Ox.	AA	LX-BZ3049GEFD	J	Screw	AA	
R2601	VRD-RA2BE331J	J	330 1/8W Carbon	AA	LX-BZ3100CEFD	J	Screw	AA	
					LX-TZ3004CEFD	J	Screw	AA	
SWITCHES									
S2501	QSW-K0202PEZZ+	J	Power	AB					
S2502	QSW-K0202PEZZ+	J	Vol-Down	AB					
S2503	QSW-K0202PEZZ+	J	Vol-Up	AB					
S2504	QSW-K0202PEZZ+	J	CH-Down	AB					
S2505	QSW-K0202PEZZ+	J	CH-Up	AB					
MISCELLANEOUS PARTS									
△ RY701	RRLYU0036CEZZ	J	Relay	AM					
△ F701	QFS-B4023CEZZ	J	Fuse, 4A(125V)	AC					
FB602	RBLN-0037CEZZ	J	Ferrite Bead	AB					
FB603	RBLN-0037CEZZ	J	Ferrite Bead	AB					
FH701	QFSDH1013CEZZ	J	Fuse Holder	AC					
FH702	QFSDH1014CEZZ	J	Fuse Holder	AC					
J903	QJAKE0211CE09	J	Jack, Audio In	AF					
J905	QJAKE0211CE04	J	Jack, Video In	AF					
P302	QPLGN0261CEZZ	J	Plug, 2-pin (S)	AB					
P401	QPLGN0561CEZZ	J	Plug, 5-pin (GBN)	AB					
P601	QPLGN0603CEZZ	J	Plug, 6-pin (K)	AB					
P651	QPLGN0361CEZZ	J	Plug, 3-pin	AB					
P701	QPLGN0260CEZZ	J	Plug, 2-pin (M)	AA					
P751	QPLGN0461CEZZ	J	Plug, 4-pin (YBN)	AB					
P2001	QPLGN0561CEZZ	J	Plug, 5-pin	AB					
RMC2601	RRMCU0230CEZZ	J	R/C Receiver	AK					
HM601	LX-GZ3002PEZZ	R	Screw	AB					
HM602	LX-GZ3002PEZZ	R	Screw	AB					
HM705	LX-GZ3001PEZZ	R	Screw	AB					
HM706	LX-GZ3001PEZZ	R	Screw	AB					
HM707	LX-GZ3001PEZZ	R	Screw	AB					
HM708	LX-GZ3001PEZZ	R	Screw	AB					
HM711	LX-GZ3001PEZZ	R	Screw	AB					
HM712	LX-GZ3001PEZZ	R	Screw	AB					
HM713	LX-GZ3001PEZZ	R	Screw	AB					
HM714	LX-GZ3001PEZZ	R	Screw	AB					
HM715	LX-GZ3001PEZZ	R	Screw	AB					
HM716	LX-GZ3001PEZZ	R	Screw	AB					
HM717	LX-GZ3001PEZZ	R	Screw	AB					

Ref. No.	Part No.	★	Description	Code	Ref. No.	Part No.	★	Description	Code
PWB-A : DUNTK9532WEX0 (20MU11)									
MAIN UNIT									
TUNER									
NOTE: THE PARTS HERE SHOWN ARE SUPPLIED AS AN ASSEMBLY BUT NOT INDEPENDENTLY									
△ TU51	VTUVTST5UF670	M	Tuner (20MU11)						
INTEGRATED CIRCUITS									
IC101	VHIKA78L05B-1+		KA78L05B	AD					
		1							
▲△ IC201	RH-iX3253CEZZ	J	TA1268AN	AV	△ D661	RH-DX0444CEZZ	J	Diode	AH
	IC351 VHiTDA7233/-1	J	TDA7233	AF	△ D701	RH-DX0154CEZZ	J	Diode	AC
△ IC501	VHiTA8403K/-1	J	TA8403K	AL	△ D702	RH-DX0154CEZZ	J	Diode	AC
▲△ IC701	VHiSTR301301E	J	STR30130	AP	△ D703	RH-DX0154CEZZ	J	Diode	AC
△ IC751	VHiKA7809Pi-1	R	KA7809PI	AD	△ D704	RH-DX0154CEZZ	J	Diode	AC
					D753	VHD1SS119//1	J	Diode	AB
					D754	VHD1SS119//1	J	Diode	AB
					D755	RH-DX0441CEZZ	J	Diode	AC
△ IC761	VHiKA7812Pi-1	R	KA7812PI	AD					
					△ D756	RH-DX0441CEZZ	J	Diode	AC
IC2001	RH-iX3256CEZZ	J	TMPA8701CMF142	AX					
IC2040	VHiPST994C/-1	J	PST994C	AD					
IC2101	VHiM24C01B/-1	J	M24C01-BN6	AF	D757	VHD1SS119//1	J	Diode	AB
					D758	RH-DX0131CEZZ	J	Diode	AC
TRANSISTORS									
Q201	VS2SC2735//1E	J	2SC2735	AC	△ D760	RH-DX0441CEZZ	J	Diode	AC
Q351	VS2SD601AR/-1	J	2SD601AR	AC					
Q401	VS2SD601AR/-1	J	2SD601AR	AC	△ D761	RH-DX0441CEZZ	J	Diode	AC
Q403	VS2SD601AR/-1	J	2SD601AR	AC					
Q404	VS2SB709AR/-1	J	2SB709AR	AC	△ D762	RH-DX0441CEZZ	J	Diode	AC
Q451	VS2SB709AR/-1	J	2SB709AR	AC					
Q501	VS2SD601AR/-1	J	2SD601AR	AC					
Q601	VS2SC2655Y/-1	J	2SC2655(Y)	AE	D763	VHD1SS119//1	J	Diode	AB
△ Q602	VS2SD2586//1E	J	2SD2586	AM	D2001	VHD1SS119//1	J	Diode	AB
					PACKAGED CIRCUITS				
Q603	VS2SC945AQ/-1	J	2SC945A(Q)	AB	PR701	RMPTP0026CEZZ	J	Packaged Circuit	AF
					X801	RCRSB0205CEZZ	J	Crystal	AF
Q752	VS2SC945AQ/-1	J	2SC945A(Q)	AB	FILTERS				
					CF301	RFiLC0403CEZZ	J	Ceramic Filter	AE
					CF401	RFiLC0013CEZZ	J	Ceramic Filter	AE
Q753	VS2SA1013//1E	J	2SA1013	AD	CF631	RFiLA0034CEZZ	J	Ceramic Filter	AD
Q2001	VS2SD601AR/-1	J	2SD601AR	AC	CF2040	RFiLC0121GEZZ	J	Ceramic Filter	AD
Q2002	VS2SD601AR/-1	J	2SD601AR	AC	SF201	RFiLC0405CEZZ	J	SAW Filter	AH
Q2060	VS2SD601AR/-1	J	2SD601AR	AC	COILS				
DIODES									
D51	RH-EX0611GEZZ	J	Zener Diode, 5.1V	AA	L201	VP-XF1R2K0000	J	Peaking 1.2μH	AB
D52	RH-EX0676GEZZ	J	Zener Diode, 32V	AA	L202	RCiLi0612CEZZ	J	VCO Coil	AE
D53	RH-EX0611GEZZ	J	Zener Diode, 5.1V	AA	L301	VP-XF8R2K0000	J	Peaking 8.2μH	AB
D401	VHD1SS119//1	J	Diode	AB	L302	RCiLi0613CEZZ	J	IF Coil	AE
D402	RH-EX0092CEZZ	J	Zener Diode, 3.9V	AB					
D454	RH-EX0103CEZZ	J	Zener Diode, 5.6V	AB					
D455	VHD1SS119//1	J	Diode	AB	L401	VP-XF120K0000	J	Peaking 12μH	AB
D501	RH-DX0441CEZZ	J	Diode	AC	L402	VP-XF100K0000	J	Peaking 10μH	AB
					L406	VP-XF680K0000	J	Peaking 68μH	AB
					L408	VP-XF100K0000	J	Peaking 10μH	AB

Ref. No.	Part No.	★	Description	Code	Ref. No.	Part No.	★	Description	Code
PWB-A : DUNTK9532WEX0 (20MU11)									
MAIN UNIT (Continued)									
△ L701	RCiLF0029PEZZ	R	Coil (20MU11)	AH	C451	RC-QZA563TAYK	J	0.056 50V	Mylar AB
△ L701	RCiLF0090CEZZ		Coil (20MU11)		C454	VCEA0A1HW475M	J	4.7 50V	EL. AB
L2040	RCiLB0159CEZZ	J	Oscillation Coil	AE	C502	VCEA0A1EW477M	J	470 25V	EL. AD
TRANSFORMERS					C504	VCKYPA2HB391K	J	390p 500V	Ceramic AA
△ T601	RTRNZ0168CEZZ	J	Transformer	AH	C505	VCQYTA1HM473K	J	0.047 50V	Mylar AB
▲△ T602	RTRNF0163PEZZ	R	H-Volt Transformer	BE	C507	VCKYPA1HB102K	J	1000p 50V	Ceramic AA
	or				C508	VCEAGA1VW107M	J	100 35V	EL. AC
	RTRNF0149PEZZ				C509	VCKYPA2HB102K	J	1000p 500V	Ceramic AA
△ T701	RTRNP0527CEZZ	J	Power Transformer	AM	C510	VCEAGA1VW477M	J	470 35V	EL. AD
	or				C511	VCQYTA1HM473K	J	0.047 50V	Mylar AB
	RTRNP0518CEZZ				C514	VCEACA1HC225J	J	2.2 50V	EL. AC
CAPACITORS					C517	VCKYCY1HB102K	J	1000p 50V	Ceramic AA
<i>[EL... Electrolytic, M-Poly... Metalized Polypro Film]</i>					C522	VCKYCY1HF103Z	J	0.01 50V	Ceramic AA
C51	VCEA0A1CW476M	J	47 16V	EL. AB	C551	RC-SATA1CE225K	J	2.2 16V	Tantalum AB
C52	VCSATA1CE226K	J	22 16V	Tantalum AD	C552	VCEA0A1HW225M	J	2.2 50V	EL. AB
C53	VCEA0A1HW105M	J	1.0 50V	EL. AB	C604	VCEA0A1CW227M	J	220 16V	EL. AC
C54	VCEA0A1HW475M	J	4.7 50V	EL. AB	▲△ C608	VCFFPD3CA802H	J	8000p 1.6kV	M-Poly. AF
	(20MU11)				C609	RC-QZA223TAYK	J	0.022 50V	Mylar AF
C54	VCEA0A1HW225M	J	2.2 50V	EL. AB	C612	VCFFPJ2EB474J	J	0.47 250V	M-Poly. AF
	(20MU11)				C631	VCEA0A1HW225M	J	2.2 50V	EL. AB
C55	VCEA0A1CW477M	J	470 16V	EL. AC	C632	VCKYCY1HF103Z	J	0.01 50V	Ceramic AA
	(20MU11)				C633	VCEA0A1HW105M	J	1.0 50V	EL. AB
C55	VCEAGA1CW108M	J	1000 16V	EL. AD	C652	VCEA0A1HW475M	J	4.7 50V	EL. AB
	(20MU11)				C653	VCEA0A1CW106M	J	10 16V	EL. AB
C201	VCKYCY1HF103Z	J	0.01 50V	Ceramic AA	C661	VCKYPA2HB152K	J	1500p 500V	Ceramic AA
C202	VCKYPA1HF103Z	J	0.01 50V	Ceramic AA	C662	VCEA0A1CW477M	J	470 16V	EL. AC
C203	VCKYCY1HF103Z	J	0.01 50V	Ceramic AA	△ C701	RC-FZ027SCEZZ	J	0.047 AC125V	Plastic
C204	VCKYCY1HF103Z	J	0.01 50V	Ceramic AA		or			
C205	VCEA0A1HW474M	J	0.47 50V	EL. AB		RC-FZ015SCEZZ			
C206	VCEA0A1CW227M	J	220 16V	EL. AC		or			
C207	VCKYCY1HF103Z	J	0.01 50V	Ceramic AA		RC-FZ002SCEZZ			
C208	VCEA0A1HW474M	J	0.47 50V	EL. AB		or			
C209	VCKYCY1HB222K	J	2200p 50V	Ceramic AA		RC-FZ059SCEZZ			
C210	VCKYCY1HB102K	J	1000p 50V	Ceramic AA		or			
C302	VCCCCY1HH330J	J	33p 50V	Ceramic AA		RC-FZ004SGEZZ			
C303	VCKYCY1HB472K	J	4700p 50V	Ceramic AA		or			
C304	VCEA0A1HW225M	J	2.2 50V	EL. AB		RC-FZ027CUMZZ			
C305	VCKYPA1HB151K	J	150p 50V	Ceramic AA	C702	VCKYPB2HE103P	J	0.01 500V	Ceramic AB
C306	VCKYPA1HF103Z	J	0.01 50V	Ceramic AA	C703	VCKYPB2HE103P	J	0.01 500V	Ceramic AB
C308	VCKYCY1HB102K	J	1000p 50V	Ceramic AA	C704	VCKYPB2HE103P	J	0.01 500V	Ceramic AB
C309	VCEA0A1CW227M	J	220 16V	EL. AC	△ C705	RC-EZ0422CEZZ	J	470 200V	EL. AN
C312	VCKYCY1HF103Z	J	0.01 50V	Ceramic AA		or			
C314	VCEA0A1HW225M	J	2.2 50V	EL. AB		RC-EZ0522CEZZ			
C351	VCKYCY1HB562K	J	5600p 50V	Ceramic AA	△ C706	RC-KZ0092GEZZ	J	3300p AC125V	Ceramic AC
C352	VCEA0A1CW107M	J	100 16V	EL. AC		or			
C353	VCEA0A1CW337M	J	330 16V	EL. AC		RC-KZ0311CEZZ			
C354	RC-QZA104TAYK	J	0.1 50V	Mylar AB	C707	VCEAGA2CW226M	J	22 160V	EL. AD
C355	VCEA0A1CW226M	J	22 16V	EL. AB	△ C712	RC-EZ0638CEZZ	J	33 160V	EL. AG
C361	VCEA0A1CW477M	J	470 16V	EL. AC	C751	VCEA0A1VW477M	J	470 35V	EL. AB
C362	VCEA0A1CW476M	J	47 16V	EL. AB	C754	VCEA0A1CW337M	J	330 16V	EL. AC
C403	VCCCCY1HH101J	J	100p 50V	Ceramic AA	C755	VCEA0A1CW107M	J	100 16V	EL. AC
C404	VCCCCY1HH680J	J	68p 50V	Ceramic AA	C756	VCEAGA1CW108M	J	1000 16V	EL. AD
C405	VCEA0A1HW335M	J	3.3 50V	EL. AB	C757	RC-QZA104TAYK	J	0.1 50V	Mylar AB
C406	VCEA0A1HW335M	J	3.3 50V	EL. AB	△ C758	VCEAGA2EW106M	J	10 250V	EL. AC
C407	RC-QZA104TAYK	J	0.1 50V	Mylar AB	C760	VCEAGA1CW108M	J	1000 16V	EL. AD
C408	VCEA0A1CW106M	J	10 16V	EL. AB	C801	RC-QZA223TAYK	J	0.022 50V	Mylar AB
C409	VCEA0A1HW105M	J	1.0 50V	EL. AB	C802	VCEA0A1HW474M	J	0.47 50V	EL. AB
C410	VCKYCY1EF104Z	J	0.1 25V	Ceramic AA	C803	VCCCCY1HH120J	J	12p 50V	Ceramic AA
C411	VCEAGA1CW108M	J	1000 16V	EL. AD	C804	VCEA0A1HW104M	J	0.1 50V	EL. AB
C413	VCKYCY1HF103Z	J	0.01 50V	Ceramic AA	C805	VCEA0A1HW104M	J	0.1 50V	EL. AB
C414	VCKYCY1EF104Z	J	0.1 25V	Ceramic AA	C806	VCEA0A1HW104M	J	0.1 50V	EL. AB
C419	VCCCCY1HH330J	J	33p 50V	Ceramic AA	C807	VCCCCY1HH820J	J	82p 50V	Ceramic AA
C420	VCCCCY1HH471J	J	470p 50V	Ceramic AA	C901	VCKYCY1EF104Z	J	0.1 25V	Ceramic AA
					C905	VCEA0A1HW335M	J	3.3 50V	EL. AB
					C2001	VCCCCY1HH101J	J	100p 50V	Ceramic AA
					C2002	VCCCCY1HH101J	J	100p 50V	Ceramic AA
					C2021	VCCCCY1HH101J	J	100p 50V	Ceramic AA
					C2022	VCCCCY1HH101J	J	100p 50V	Ceramic AA
					C2023	VCCCCY1HH101J	J	100p 50V	Ceramic AA
					C2024	VCCCCY1HH101J	J	100p 50V	Ceramic AA
					C2040	VCEA0A1AW107M	J	100 10V	EL. AB
					C2041	VCEA0A1HW105M	J	1.0 50V	EL. AB
					C2051	VCCCCY1HH101J	J	100p 50V	Ceramic AA
					C2060	RC-QZA104TAYK	J	0.1 50V	Mylar AB
					C2061	VCKYD41HB101K	J	100p 50V	Ceramic AA

Ref. No.	Part No.	★	Description	Code
----------	----------	---	-------------	------

PWB-A : DUNTK9532WEX0 (20MU11)

MAIN UNIT (Continued)

C2062	VCEA0A1AW107M	J	100 10V EL.	AB
C2402	VCCCCY1HH560J	J	56p 50V Ceramic	AA
C2601	VCEA0A1HW475M	J	4.7 50V EL.	AB
C2602	VCCCCY1HH101J	J	100p 50V Ceramic	AA

RESISTORS

[M-Ox... Metal Oxide, M-Film ... Metal Film]

RJ1	VRS-CY1JF000J	J	0 1/16W M-Ox.	AA
RJ3	VRS-CY1JF000J	J	0 1/16W M-Ox.	AA
RJ5	VRS-CY1JF000J	J	0 1/16W M-Ox.	AA
RJ6	VRS-CY1JF000J	J	0 1/16W M-Ox.	AA
RJ7	VRS-CY1JF000J	J	0 1/16W M-Ox.	AA
RJ9	VRS-CY1JF000J	J	0 1/16W M-Ox.	AA
RJ10	VRS-CY1JF000J	J	0 1/16W M-Ox.	AA
RJ15	VRS-CY1JF000J	J	0 1/16W M-Ox.	AA
RJ17	VRS-CY1JF000J	J	0 1/16W M-Ox.	AA
RJ18	VRS-CY1JF000J	J	0 1/16W M-Ox.	AA
RJ19	VRS-CY1JF000J	J	0 1/16W M-Ox.	AA
RJ20	VRS-CY1JF000J	J	0 1/16W M-Ox.	AA
RJ21	VRS-CY1JF000J	J	0 1/16W M-Ox.	AA
RJ23	VRS-CY1JF000J	J	0 1/16W M-Ox.	AA
RJ24	VRS-CY1JF000J	J	0 1/16W M-Ox.	AA
RJ26	VRS-CY1JF000J	J	0 1/16W M-Ox.	AA
RJ31	VRS-CY1JF000J	J	0 1/16W M-Ox.	AA
RJ32	VRS-CY1JF000J	J	0 1/16W M-Ox.	AA
RJ35	VRS-CY1JF000J	J	0 1/16W M-Ox.	AA
RJ39	VRS-CY1JF000J	J	0 1/16W M-Ox.	AA
RJ40	VRS-CY1JF000J	J	0 1/16W M-Ox.	AA
RJ46	VRS-CY1JF000J	J	0 1/16W M-Ox.	AA
RJ49	VRS-CY1JF000J	J	0 1/16W M-Ox.	AA
RJ52	VRS-CY1JF000J	J	0 1/16W M-Ox.	AA
RJ54	VRS-CY1JF000J	J	0 1/16W M-Ox.	AA
RJ55	VRS-CY1JF000J	J	0 1/16W M-Ox.	AA
RJ57	VRS-CY1JF000J	J	0 1/16W M-Ox.	AA
RJ59	VRS-CY1JF000J	J	0 1/16W M-Ox.	AA
RJ62	VRS-CY1JF000J	J	0 1/16W M-Ox.	AA
RJ63	VRS-CY1JF000J	J	0 1/16W M-Ox.	AA
RJ66	VRS-CY1JF000J	J	0 1/16W M-Ox.	AA
RJ67	VRS-CY1JF000J	J	0 1/16W M-Ox.	AA
RJ68	VRS-CY1JF000J	J	0 1/16W M-Ox.	AA
RJ69	VRS-CY1JF000J	J	0 1/16W M-Ox.	AA
RJ71	VRS-CY1JF000J	J	0 1/16W M-Ox.	AA
RJ75	VRS-CY1JF000J	J	0 1/16W M-Ox.	AA
RJ77	VRS-CY1JF000J	J	0 1/16W M-Ox.	AA
RJ78	VRS-CY1JF000J	J	0 1/16W M-Ox.	AA
RJ79	VRS-CY1JF000J	J	0 1/16W M-Ox.	AA
△ R51	VRS-VV3AB331J	J	330 1W M-Ox.	AA
			(20MU11)	
△ R51	VRS-VV3DB151J	J	150 2W M-Ox.	AA
			(20MU11)	
△ R52	VRS-VV3DB470J	J	47 2W M-Ox.	AA
			(20MU11)	
△ R52	VRS-VV3DB1R0J	J	1.0 2W M-Film	AB
			(20MU11)	
△ R53	VRS-VV3LB223J	J	22k 3.0W M-Ox.	AB
R54	VRS-CY1JF101J	J	100 1/16W M-Ox.	AA
R55	VRS-CY1JF101J	J	100 1/16W M-Ox.	AA
R56	VRS-CY1JF823J	J	82k 1/16W M-Ox.	AA
R57	VRS-CY1JF392J	J	3.9k 1/16W M-Ox.	AA
			(20MU11)	
R57	VRS-CY1JF103J	J	10k 1/16W M-Ox.	AA
			(20MU11)	
R201	VRS-CY1JF221J	J	220 1/16W M-Ox.	AA
R202	VRS-CY1JF122J	J	1.2k 1/16W M-Ox.	AA
R203	VRD-RA2BE682J	J	6.8k 1/8W Carbon	AA
R204	VRS-CY1JF270J	J	27 1/16W M-Ox.	AA
R205	VRD-RA2BE391J	J	390 1/8W Carbon	AA
R206	VRD-RA2EE151J	J	150 1/4W Carbon	AA
R208	VRS-CY1JF391J	J	390 1/16W M-Ox.	AA

Ref. No.	Part No.	★	Description	Code
----------	----------	---	-------------	------

R301	VRD-RA2BE222J	J	2.2k 1/8W Carbon	AA
R302	VRS-CY1JF102J	J	1.0k 1/16W M-Ox.	AA
R303	VRS-CY1JF153J	J	15k 1/16W M-Ox.	AA
R307	VRS-CY1JF333J	J	33k 1/16W M-Ox.	AA
R352	VRS-CY1JF332J	J	3.3k 1/16W M-Ox.	AA
R353	VRS-CY1JF4R7J	J	4.7 1/16W M-Ox.	AA
R354	VRS-CY1JF152J	J	1.5k 1/16W M-Ox.	AA
R361	VRD-RA2BE102J	J	1.0k 1/8W Carbon	AA
R364	VRS-CY1JF473J	J	47k 1/16W M-Ox.	AA
R401	VRS-CY1JF682J	J	6.8k 1/16W M-Ox.	AA
R403	VRD-RA2BE331J	J	330 1/8W Carbon	AA
R404	VRS-CY1JF391J	J	390 1/16W M-Ox.	AA
R407	VRS-CY1JF471J	J	470 1/16W M-Ox.	AA
R409	VRS-CY1JF471J	J	470 1/16W M-Ox.	AA
R410	VRD-RA2BE563J	J	56k 1/8W Carbon	AA
R411	VRS-CY1JF103J	J	10k 1/16W M-Ox.	AA
R412	VRD-RA2EE561J	J	560 1/4W Carbon	AA
R413	VRD-RA2BE470J	J	47 1/8W Carbon	AA
R414	VRD-RA2BE470J	J	47 1/8W Carbon	AA
R415	VRD-RA2BE470J	J	47 1/8W Carbon	AA
R416	VRS-CY1JF102J	J	1.0k 1/16W M-Ox.	AA
R417	VRD-RA2BE101J	J	100 1/8W Carbon	AB
R418	VRS-CY1JF152J	J	1.5k 1/16W M-Ox.	AA
R419	VRS-CY1JF472J	J	4.7k 1/16W M-Ox.	AA
R423	VRS-CY1JF222J	J	2.2k 1/16W M-Ox.	AA
R426	VRS-CY1JF271J	J	270 1/16W M-Ox.	AA
R440	VRS-CY1JF821J	J	820 1/16W M-Ox.	AA
△ R451	VRS-SV2HC103J	J	10k 1/2W M-Ox.	AA
R452	VRD-RA2BE152J	J	1.5k 1/8W Carbon	AA
R454	VRD-RA2BE334J	J	330k 1/8W Carbon	AA
R455	VRD-RA2BE392J	J	3.9k 1/8W Carbon	AA
R456	VRS-CY1JF223J	J	22k 1/16W M-Ox.	AA
R457	VRD-RA2BE102J	J	1.0k 1/8W Carbon	AA
R458	VRD-RA2BE334J	J	330k 1/8W Carbon	AA
R459	VRD-RA2BE123J	J	12k 1/8W Carbon	AA
R504	VRD-RA2BE471J	J	470 1/8W Carbon	AA
R505	VRS-CY1JF101J	J	100 1/16W M-Ox.	AA
R506	VRD-RA2BE683G	J	68k 1/8W Carbon	AA
R507	VRD-RA2BE104G	J	100k 1/8W Carbon	AA
R508	VRD-RA2BE473J	J	47k 1/8W Carbon	AA
R510	VRD-RM2HD1R2J	J	1.2 1/2W Carbon	AA
△ R511	VRN-SV2HB1R5J	J	1.5 1/2W M-Film	AB
R512	VRD-RM2HD681J	J	680 1/2W Carbon	AA
R516	VRD-RA2BE683G	J	68k 1/8W Carbon	AA
R517	VRD-RA2BE103G	J	10k 1/8W Carbon	AA
R518	VRD-RA2BE154J	J	150k 1/8W Carbon	AA
R524	VRS-CY1JF332J	J	3.3k 1/16W M-Ox.	AA
R525	VRD-RA2BE473J	J	47k 1/8W Carbon	AA
R552	VRD-RA2BE102J	J	1.0k 1/8W Carbon	AA
R553	VRS-CY1JF273J	J	27k 1/16W M-Ox.	AA
R554	VRS-CY1JF472J	J	4.7k 1/16W M-Ox.	AA
R555	VRS-CY1JF102J	J	1.0k 1/16W M-Ox.	AA
R556	VRS-CY1JF102J	J	1.0k 1/16W M-Ox.	AA
R602	VRD-RA2EE820J	J	82 1/4W Carbon	AA
△ R603	VRS-VV3LB220J	J	22 3.0W M-Ox.	AB
R605	VRS-CY1JF332J	J	3.3k 1/16W M-Ox.	AA
R606	VRD-RA2BE102J	J	1.0k 1/8W Carbon	AA
R608	VRD-RA2BE101J	J	100 1/8W Carbon	AB
R609	VRD-RA2BE331J	J	330 1/8W Carbon	AA
△ R610	VRS-VV3DB391J	J	390 2W M-Ox.	AA
R620	VRD-RA2BE473J	J	47k 1/8W Carbon	AA
R621	VRS-CY1JF682J	J	6.8k 1/16W M-Ox.	AA
R631	VRS-CY1JF391J	J	390 1/16W M-Ox.	AA
R632	VRS-CY1JF152J	J	1.5k 1/16W M-Ox.	AA
R633	VRS-CY1JF472J	J	4.7k 1/16W M-Ox.	AA
R634	VRD-RM2HD121J	J	120 1/2W Carbon	AA
△ R641	VRS-VV3AB682J	J	6.8k 1W M-Ox.	AA
R642	VRD-RA2BE821J	J	820 1/8W Carbon	AA
▲▲ R651	VRD-RM2HD1R0J	J	1.0 1/2W Carbon	AA
▲▲ R654	VRD-RA2BE154J	J	150k 1/8W Carbon	AA
▲▲ R655	VRS-CY1JF104J	J	100k 1/16W M-Ox.	AA
▲▲ R656	VRS-CY1JF273J	J	27k 1/16W M-Ox.	AA
△ R659	VRN-VV3AB1R0J	J	1.0 1W M-Film	AA
△ R661	VRN-VV3ABR47J	J	0.47 1W M-Film	AA

Ref. No.	Part No.	★	Description	Code
----------	----------	---	-------------	------

PWB-A : DUNTK9532WEX0 (20MU11)

MAIN UNIT (Continued)

△ R701	RR-HZ0046CEZZ or RR-DZ0047CEZZ or VRC-UB2HG275K	J	2.7M 1/2W	Solid	AD
△ R702	VRW-KP3HC1R8K	J	1.8 5W	Cement	AC
△ R703	VRS-KA3NG681J	J	680 7.0W	M-Ox.	AF
R704	VRD-RM2HD123J	J	12k 1/2W	Carbon	AA
R705	VRD-RA2EE334J	J	330k 1/4W	Carbon	AA
R706	VRD-RM2HD470J	J	47 1/2W	Carbon	AA
△ R707	VRN-VV3DB1R5J	J	1.5 2W	M-Film	AB
△ R708	VRD-RM2HD824J	J	820k 1/2W	Carbon	AA
△ R709	VRS-KA3NG681J	J	680 7.0W	M-Ox.	AF
△ R711	VRS-KA3NG681J	J	680 7.0W	M-Ox.	AF
△ R717	VRS-KA3HG3R3K	J	3.3 5W	M-Ox.	AD
△ R730	VRS-VV3DB270J	J	27 2W	M-Ox.	AA
△ R750	VRS-VV3AB561J	J	560 1W	M-Ox.	AA
R752	VRD-RA2BE562J	J	5.6k 1/8W	Carbon	AA
R754	VRS-CY1JF471J	J	470 1/16W	M-Ox.	AA
△ R755	VRS-VV3DB470J	J	47 2W	M-Ox.	AA
R757	VRS-CY1JF472J	J	4.7k 1/16W	M-Ox.	AA
△ R758	VRS-SV2HC100J	J	10 1/2W	M-Ox.	AA
R801	VRS-CY1JF332J	J	3.3k 1/16W	M-Ox.	AA
R802	VRS-CY1JF332J	J	3.3k 1/16W	M-Ox.	AA
R803	VRS-CY1JF182J	J	1.8k 1/16W	M-Ox.	AA
R804	VRS-CY1JF182J	J	1.8k 1/16W	M-Ox.	AA
R805	VRS-CY1JF182J	J	1.8k 1/16W	M-Ox.	AA
R806	VRS-CY1JF333J	J	33k 1/16W	M-Ox.	AA
R902	VRS-CY1JF750J	J	75 1/16W	M-Ox.	AA
R906	VRS-CY1JF102J	J	1.0k 1/16W	M-Ox.	AA
R925	VRS-CY1JF104J	J	100k 1/16W	M-Ox.	AA
R961	VRS-CY1JF101J	J	100 1/16W	M-Ox.	AA
R962	VRS-CY1JF101J	J	100 1/16W	M-Ox.	AA
R2001	VRD-RA2BE102J	J	1.0k 1/8W	Carbon	AA
R2002	VRS-CY1JF103J	J	10k 1/16W	M-Ox.	AA
R2006	VRS-CY1JF103J	J	10k 1/16W	M-Ox.	AA
R2007	VRD-RA2BE223J	J	22k 1/8W	Carbon	AA
R2008	VRD-RA2BE224J	J	220k 1/8W	Carbon	AA
R2009	VRS-CY1JF102J	J	1.0k 1/16W	M-Ox.	AA
R2010	VRS-CY1JF102J	J	1.0k 1/16W	M-Ox.	AA
R2011	VRS-CY1JF821J	J	820 1/16W	M-Ox.	AA
R2012	VRS-CY1JF471J	J	470 1/16W	M-Ox.	AA
R2020	VRD-RM2HD223J	J	22k 1/2W	Carbon	AA
R2022	VRD-RA2BE333J	J	33k 1/8W	Carbon	AA
R2024	VRD-RA2BE682J	J	6.8k 1/8W	Carbon	AA
R2025	VRD-RA2BE682J	J	6.8k 1/8W	Carbon	AA
R2026	VRD-RA2BE682J	J	6.8k 1/8W	Carbon	AA
R2027	VRD-RA2BE682J	J	6.8k 1/8W	Carbon	AA
R2028	VRD-RA2BE102J	J	1.0k 1/8W	Carbon	AA
R2029	VRS-CY1JF102J	J	1.0k 1/16W	M-Ox.	AA
R2032	VRS-CY1JF471J	J	470 1/16W	M-Ox.	AA
R2033	VRD-RA2BE103J	J	10k 1/8W	Carbon	AA
R2040	VRS-CY1JF102J	J	1.0k 1/16W	M-Ox.	AA
R2041	VRS-CY1JF333J	J	33k 1/16W	M-Ox.	AA
R2042	VRS-CY1JF101J	J	100 1/16W	M-Ox.	AA
R2043	VRS-CY1JF101J	J	100 1/16W	M-Ox.	AA
R2044	VRS-CY1JF683J	J	68k 1/16W	M-Ox.	AA
R2045	VRS-CY1JF101J	J	100 1/16W	M-Ox.	AA
R2047	VRS-CY1JF221J	J	220 1/16W	M-Ox.	AA
R2048	VRD-RA2BE562J	J	5.6k 1/8W	Carbon	AA
R2049	VRS-CY1JF333J	J	33k 1/16W	M-Ox.	AA
R2054	VRS-CY1JF222J	J	2.2k 1/16W	M-Ox.	AA
R2055	VRS-CY1JF103J	J	10k 1/16W	M-Ox.	AA
R2060	VRS-CY1JF221J	J	220 1/16W	M-Ox.	AA
R2061	VRS-CY1JF562J	J	5.6k 1/16W	M-Ox.	AA
R2062	VRS-CY1JF183J	J	18k 1/16W	M-Ox.	AA
R2063	VRD-RA2BE222J	J	2.2k 1/8W	Carbon	AA
R2064	VRD-RA2BE332J	J	3.3k 1/8W	Carbon	AA
R2066	VRS-CY1JF103J	J	10k 1/16W	M-Ox.	AA

Ref. No.	Part No.	★	Description	Code
----------	----------	---	-------------	------

R2067	VRS-CY1JF103J	J	10k 1/16W	M-Ox.	AA
R2068	VRS-CY1JF103J	J	10k 1/16W	M-Ox.	AA
R2070	VRS-CY1JF103J	J	10k 1/16W	M-Ox.	AA
R2101	VRS-CY1JF101J	J	100 1/16W	M-Ox.	AA
R2102	VRS-CY1JF101J	J	100 1/16W	M-Ox.	AA
R2401	VRS-CY1JF101J	J	100 1/16W	M-Ox.	AA
R2402	VRS-CY1JF101J	J	100 1/16W	M-Ox.	AA
R2403	VRS-CY1JF101J	J	100 1/16W	M-Ox.	AA
R2404	VRS-CY1JF101J	J	100 1/16W	M-Ox.	AA
R2501	VRS-CY1JF123J	J	12k 1/16W	M-Ox.	AA
R2503	VRS-CY1JF273J	J	27k 1/16W	M-Ox.	AA
R2504	VRS-CY1JF123J	J	12k 1/16W	M-Ox.	AA
R2505	VRS-CY1JF563J	J	56k 1/16W	M-Ox.	AA
R2506	VRS-CY1JF563J	J	56k 1/16W	M-Ox.	AA
R2507	VRS-CY1JF823J	J	82k 1/16W	M-Ox.	AA
R2508	VRS-CY1JF153J	J	15k 1/16W	M-Ox.	AA
R2509	VRS-CY1JF272J	J	2.7k 1/16W	M-Ox.	AA
R2601	VRD-RA2BE331J	J	330 1/8W	Carbon	AA

SWITCHES

S2501	QSW-K0079GEZZ	J	Power	AB
S2502	QSW-K0079GEZZ	J	Vol-Down	AB
S2503	QSW-K0079GEZZ	J	Vol-Up	AB
S2504	QSW-K0079GEZZ	J	CH-Down	AB
S2505	QSW-K0079GEZZ	J	CH-Up	AB

MISCELLANEOUS PARTS

△ RY701	RRLYU0036CEZZ or RRLYU0038CEZZ or RRLYU0077CEZZ	J	Relay	AM
△ F701	QFS-B4023CEZZ or QFS-B4021GEZZ	J	Fuse, 4A(125V)	AC
FB602	RBLN-0037CEZZ	J	Ferrite Bead	AB
FB603	RBLN-0037CEZZ	J	Ferrite Bead	AB
FH701	QFSHD1013CEZZ or QFSHD1013CEZZ	J	Fuse Holder	AC
FH702	QFSHD1014CEZZ or QFSHD1010CEZZ	J	Fuse Holder	AC
J903	QJAKE0159CEZZ	J	Jack, Audio IN	AF
J905	QJAKE0158CEZZ	J	Jack, Video IN	AF
P302	QPLGN0261CEZZ	J	Plug, 4-pin (S)	AB
P401	QPLGN0561CEZZ	J	Plug, 5-pin (GBN)	AB
P601	QPLGN0603CEZZ	J	Plug, 6-pin (K)	AB
P651	QPLGN0361CEZZ	J	Plug, 3-pin	AB
P701	QPLGN0207CEZZ	J	Plug, 2-pin (M)	AA
P751	QPLGN0461CEZZ	J	Plug, 4-pin (YBN)	AB
P2001	QPLGN0561CEZZ	J	Plug, 5-pin	AB
RMC2601	RRMCU0227CEZZ or RRMCU0235CEZZ or RRMCU0222CEZZ	J	R/C Receiver	AK
HM601	LX-GZ3002PEZZ	R	Screw	AB
HM602	LX-GZ3002PEZZ	R	Screw	AB
HM705	LX-GZ3001PEZZ	R	Screw	AB
HM706	LX-GZ3001PEZZ	R	Screw	AB
HM707	LX-GZ3001PEZZ	R	Screw	AB
HM708	LX-GZ3001PEZZ	R	Screw	AB
HM711	LX-GZ3001PEZZ	R	Screw	AB
HM712	LX-GZ3001PEZZ	R	Screw	AB
HM713	LX-GZ3001PEZZ	R	Screw	AB
HM714	LX-GZ3001PEZZ	R	Screw	AB
HM715	LX-GZ3001PEZZ	R	Screw	AB
HM716	LX-GZ3001PEZZ	R	Screw	AB
HM717	LX-GZ3001PEZZ	R	Screw	AB
HM718	LX-GZ3001PEZZ	R	Screw	AB
HM719	LX-GZ3001PEZZ	R	Screw	AB
HM720	LX-GZ3001PEZZ	R	Screw	AB
HM722	LX-GZ3002PEZZ	R	Screw	AB
HM724	LX-GZ3002PEZZ	R	Screw	AB

Ref. No.	Part No.	★	Description	Code
----------	----------	---	-------------	------

PWB-A : DUNTK9532WEX0 (20MU11)**MAIN UNIT (Continued)**

HM726	LX-GZ3002PEZZ	R	Screw	AB
HM729	LX-GZ3001PEZZ	R	Screw	AB
HM730	LX-GZ3001PEZZ	R	Screw	AB
HM734	LX-GZ3002PEZZ	R	Screw	AB
HM735	LX-GZ3002PEZZ	R	Screw	AB
HM739	LX-GZ3002PEZZ	R	Screw	AB
HM740	LX-GZ3002PEZZ	R	Screw	AB
HM741	LX-GZ3002PEZZ	R	Screw	AB
HM742	LX-GZ3002PEZZ	R	Screw	AB
HM743	LX-GZ3002PEZZ	R	Screw	AB
RDA501	PRDAR0103GJFW	X	Heat Sink, for IC501	AN
RDA602	PRDAR0216PEFW	R	Heat Sink, for Q602	AE
RDA701	PRDAR0238PEFW	R	Heat Sink, for IC701	AN
TP701	QLUGP0102PEZZ	R	Lug	AA
	PZETM0016CEZZ	J	Insulator	AB
	LX-BZ3049GEFD	J	Screw	AA
	LX-BZ3100CEFD	J	Screw	AA
	LX-TZ3004CEFD	J	Screw	AA

Ref. No.	Part No.	★	Description	Code
----------	----------	---	-------------	------

**PWB-B : DUNTK9530WEV6 (20MU11)
CRT UNIT****TRANSISTORS**

Q852	VS2SC2229O/1E	J	2SC2229 (O)	AD
Q854	VS2SC2229O/1E	J	2SC2229 (O)	AD
Q856	VS2SC2229O/1E	J	2SC2229 (O)	AD
Q881	VS2SA1266-Y-1	J	2SA1266 (Y)	AA
	or			
	VS2SA1015Y/1E			

DIODES

You can substitute "RH-DX0045GEZZ" or "VHD-DX0446CEZZ" for "VHD1SS119//-1".

D881	VHD1SS119//-1	J	Diode	AB
D882	VHD1SS119//-1	J	Diode	AB
D885	VHD1SS119//-1	J	Diode	AB

COIL

L851	VP-DF151K0000	J	Peaking 150µH	AB
------	---------------	---	---------------	----

CAPACITORS

[EL.... Electrolytic]

C851	VCCCCY1HH271J	J	270p 50V Ceramic	AA
C852	VCCCCY1HH271J	J	270p 50V Ceramic	AA
C853	VCCCCY1HH271J	J	270p 50V Ceramic	AA
C854	RC-KZ0029CEZZ	J	0.01 1.4kV Ceramic	AC
C881	VCEA0A1CW106M	J	10 16V EL.	AB
C883	VCEA0A1CW336M	J	33 16V EL.	AB

RESISTORS

[M-Ox.... Metal Oxide]

R851	VRS-CY1JF470J	J	47 1/16W M-Ox.	AA
R852	VRD-RA2BE221J	J	220 1/8W Carbon	AA
R853	VRS-CY1JF121J	J	120 1/16W M-Ox.	AA
△ R857	VRS-VV3AB123J	J	12k 1W M-Ox.	AA
R858	VRD-RM2HD332J	J	3.3k 1/2W Carbon	AA
R859	VRS-CY1JF470J	J	47 1/16W M-Ox.	AA
R860	VRD-RA2BE221J	J	220 1/8W Carbon	AA
R861	VRS-CY1JF121J	J	120 1/16W M-Ox.	AA
△ R865	VRS-VV3AB123J	J	12k 1W M-Ox.	AA
R866	VRD-RM2HD332J	J	3.3k 1/2W Carbon	AA
R867	VRD-RA2BE470J	J	47 1/8W Carbon	AA
R868	VRS-CY1JF221J	J	220 1/16W M-Ox.	AA
R869	VRS-CY1JF121J	J	120 1/16W M-Ox.	AA
△ R873	VRS-VV3AB123J	J	12k 1W M-Ox.	AA
R874	VRD-RM2HD332J	J	3.3k 1/2W Carbon	AA
R881	VRS-CY1JF561J	J	560 1/16W M-Ox.	AA
R882	VRS-CY1JF391J	J	390 1/16W M-Ox.	AA
R883	VRD-RA2BE561J	J	560 1/8W Carbon	AA
R884	VRS-CY1JF152J	J	1.5k 1/16W M-Ox.	AA
R886	VRS-CY1JF431J	J	430 1/16W M-Ox.	AA
R887	VRS-CY1JF470J	J	47 1/16W M-Ox.	AA

MICELLANEOUS PARTS

P851	QPLGN0561CEZZ	J	Plug, 5-pin (GBN)	AB
P852	QPLGN0461CEZZ	J	Plug, 4-pin (YBN)	AB
SC851	QSOCV0840CEZZ	J	CRT Socket	

Ref. No.	Part No.	★	Description	Code
----------	----------	---	-------------	------

PWB-B : DUNTK9533WEV4(20MU11)**CRT UNIT****TRANSISTORS**

Q852	VS2SC2229O/1E	J	2SC2229 (O)	AD
Q854	VS2SC2229O/1E	J	2SC2230 (O)	AD
Q856	VS2SC2229O/1E	J	2SC2231 (O)	AD
Q881	VS2SA1266-Y-1	J	2SA1266 (Y)	AA
	or			
	VS2SA1015Y/1E			

DIODES

You can substitute "RH-DX0045GEZZ" or "VHD-DX0446CEZZ" for "VHD1SS119//-1".

D881	VHD1SS119//-1	J	Diode	AB
D882	VHD1SS119//-1	J	Diode	AB
D885	VHD1SS119//-1	J	Diode	AB

COIL

L851	VP-DF151K0000	J	Peaking 150µH	AB
------	---------------	---	---------------	----

CAPACITORS

[EL... Electrolytic]

C851	VCCCCY1HH271J	J	270p 50V	Ceramic	AA
C852	VCCCCY1HH271J	J	270p 50V	Ceramic	AA
C853	VCCCCY1HH271J	J	270p 50V	Ceramic	AA
C854	RC-KZ0029CEZZ	J	0.01 1.4kV	Ceramic	AC
C881	VCEA0A1CW106M	J	10 16V	EL.	AB
C883	VCEA0A1CW336M	J	33 16V	EL.	AB

RESISTORS

[M-Ox... Metal Oxide]

R851	VRS-CY1JF470J	J	47 1/16W	M-Ox.	AA
R852	VRD-RA2BE221J	J	220 1/8W	Carbon	AA
R853	VRS-CY1JF121J	J	120 1/16W	M-Ox.	AA
△ R857	VRS-VV3AB123J	J	12k 1W	M-Ox.	AA
R858	VRD-RM2HD332J	J	3.3k 1/2W	Carbon	AA
R859	VRD-RA2BE470J	J	47 1/8W	Carbon	AA
R860	VRS-CY1JF221J	J	220 1/16W	M-Ox.	AA
R861	VRS-CY1JF121J	J	120 1/16W	M-Ox.	AA
△ R865	VRS-VV3AB123J	J	12k 1W	M-Ox.	AA
R866	VRD-RM2HD332J	J	3.3k 1/2W	Carbon	AA
R867	VRS-CY1JF470J	J	47 1/16W	M-Ox.	AA
R868	VRD-RA2BE221J	J	220 1/8W	Carbon	AA
R869	VRS-CY1JF121J	J	120 1/16W	M-Ox.	AA
△ R873	VRS-VV3AB123J	J	12k 1W	M-Ox.	AA
R874	VRD-RM2HD332J	J	3.3k 1/2W	Carbon	AA
R881	VRS-CY1JF561J	J	560 1/16W	M-Ox.	AA
R882	VRS-CY1JF391J	J	390 1/16W	M-Ox.	AA
R883	VRD-RA2BE561J	J	560 1/8W	Carbon	AA
R884	VRS-CY1JF152J	J	1.5k 1/16W	M-Ox.	AA
R886	VRS-CY1JF431J	J	430 1/16W	M-Ox.	AA
R887	VRS-CY1JF470J	J	47 1/16W	M-Ox.	AA

MICELLANEOUS PARTS

P851	QPLGN0561CEZZ	J	Plug, 5-pin (GBN)	AB
P852	QPLGN0461CEZZ	J	Plug, 4-pin (YBN)	AB
SC851	QSOCV0929CEZZ	J	CRT Socket	AM
	or			
	QSOCV0933CEZZ			

Ref. No.	Part No.	★	Description	Code
----------	----------	---	-------------	------

CABINET PARTS

1	CCABA0006WEH5	X	Front Cabinet Ass'y (20MU11)	
1-2	GCOVA0003GJSA	X	Cover for R/C	
1-3	HBDGB1001GJSA	X	Badge, "SHARP"	
1-4	JBTN-0003GJSA	X	Button	
2	GCABB0156GJKA	X	Rear Cabinet	

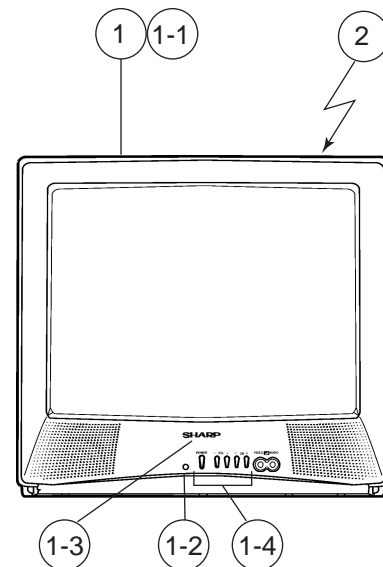
CABINET PARTS LOCATION

Ref. No.	Part No.	★	Description	Code
----------	----------	---	-------------	------

Ref. No.	Part No.	★	Description	Code
----------	----------	---	-------------	------

MISCELLANEOUS PARTS

△ ACC701	QACCD3064CESA	M	AC Cord	AM
	or			
	QACCD3060CESA			
	QCNW-2110PEZZ	R	Connecting Cord (20MU11)	AG
	QCNW-2111PEZZ	R	Connecting Cord	AF
	QCNW-2112PEZZ	R	Connecting Cord	AF
	QCNW-2160PEZZ	R	Connecting Cord (20MU11)	AG
SP1	VSP0080PBK98A	M	Speaker, 8 ohm	AG

SUPPLIED ACCESORRIES

TGAN-0001GJZZ	X	Guarantee Card (20MU11)	
TINS-A753WJZZ	X	Operation Manual (20MU11)	
RRMCG1339CESB	M	Infrared R/C Unit (20MU11)	AT

PACKING PARTS (NOT REPLACEMENT ITEM)

SPAKCA717WJZZ	-	Packing Case (20MU11)	—
SPAKP0001GJZZ	-	Polyethylene Cover	—
SPAKX0003GJZZ	-	Buffer Material	—
SSAKA0101GJZZ	-	Polyethylene Bag	—

PACKING OF THE SET

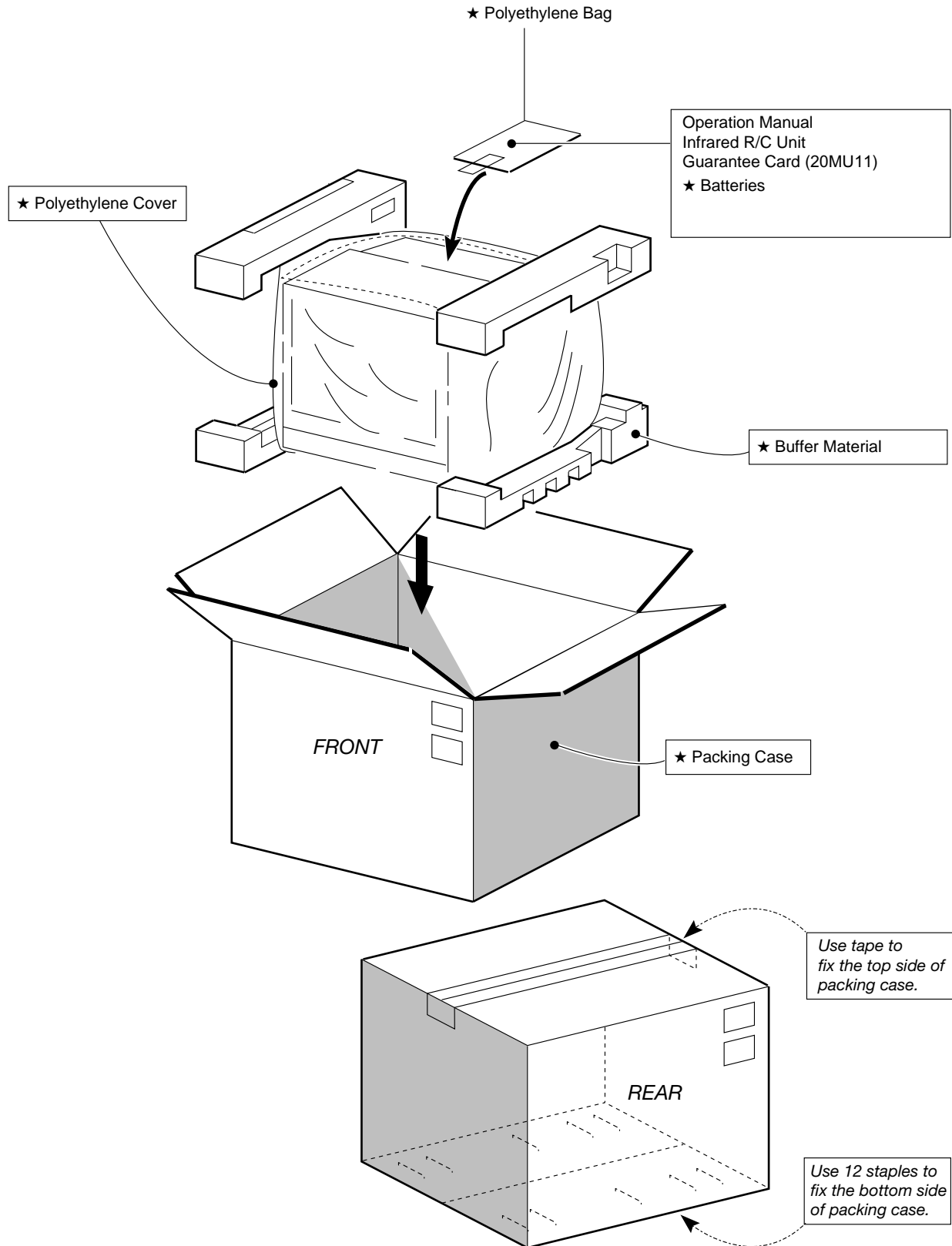

★ MARK : Not replacement items.

SHARP

COPYRIGHT © 2003 BY SHARP CORPORATION

ALL RIGHTS RESERVED.

No part of this publication may be reproduced, stored in a retrieval system, or transmitted in any form or by any means, electronic, mechanical, photocopying, recording, or otherwise, without prior written permission of the publisher.

QRC0002-L
May. 2003
Modify : SEMEX

Design and Production Information

Design base : JAPAN
Production : SEMEX

J B

SHARP ELECTRONICA MEXICO S. A. DE C. V.
Quality & Reliability Control Center
Bld. SHARP No. 3510 Parque Industrial Rosarito
Playas de Rosarito, México B. C. 22710