



These components are RoHS compliant



OPI 1000L Series

Optically Coupled Isolators
Surface Mount Low Profile
ATEX & IECEx CERTIFIED

The OPI 1000L A through E are a series of Optically Coupled Isolators each consisting of a Infrared emitter coupled to a silicon photo transistor. The series is designed for applications requiring high voltage isolation between input & output.

- Surface Mount configuration in Tape & Reel
- High Current Transfer ratio– 40% min @ 1mA If
- Low Profile
- 10KV isolation

ATEX

CERTIFICATE No. - BAS01ATEX1278U/5

Confirmed conform to:-
 EN60079-0:2012
 EN60079-11:2012
 EN60079-26:2007

Conditions of use apply:- See 'Schedule of limitations' on certificate / Details repeated on Page 5 of this datasheet.

CERTIFICATE No. IECEx BAS 06.0021U/4

Confirmed conform to:-
 IEC 60079-0:2011 Edition 6
 IEC 60079-11:2011 Edition 6
 IEC 60079-26:2006 Edition 2

Conditions of use apply:- See Schedule of limitations on certificate / Details repeated on Page 5 of this datasheet.

MECHANICAL DATA

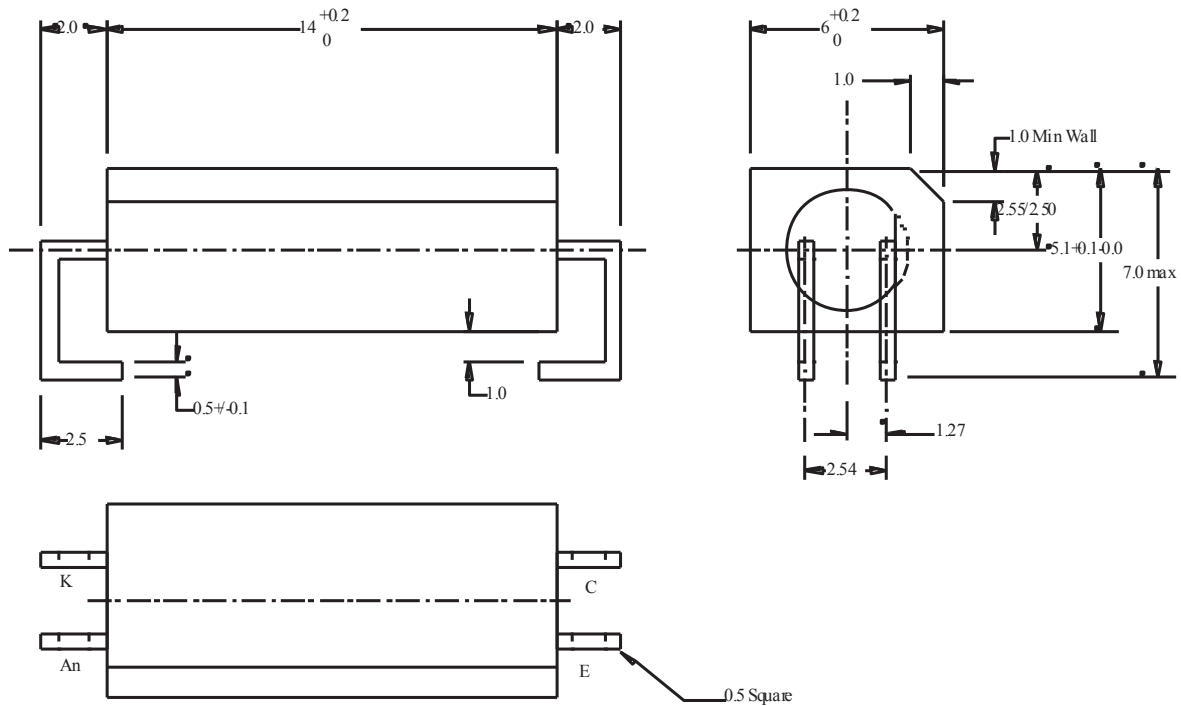

BEDFORD OPTO TECHNOLOGY LTD
1, BIGGAR BUSINESS PARK, BIGGAR, LANARKSHIRE, ML12 6FX
 Tel: +44 (0) 1899 221221 Fax: +44 (0) 1899 221009
 Website: bot.co.uk E-mail: bill@bot.co.uk



This component is RoHS compliant



ABSOLUTE MAXIMUM RATINGS (25°C unless otherwise noted)

INPUT DIODE FORWARD DC CURRENT REVERSE DC VOLTAGE POWER DISSIPATION	100mA 5 Volts 165mW (ii)
OUTPUT TRANSISTOR COLLECTOR-EMITTER VOLTAGE COLLECTOR CURRENT POWER DISSIPATION	35 Volts 15 mA 165mW (iii)
OPERATING TEMP	-40°C TO +85°C
STORAGE TEMP	-40°C TO +85°C
INPUT-TO-OUTPUT ISOLATION VOLTAGE	± 10KV DC (i)

Notes

- i) Measured with the input leads and output leads shorted together for one min.
- ii) Thermal resistance 375 K/W
- iii) Thermal resistance 450 K/W

Whilst the devices are capable of operating continually at the noted elevated temperatures users should be aware of the possibility of a reduction in CTR over long periods at high temperatures & currents.

RECOMMENDED FOOTPRINT

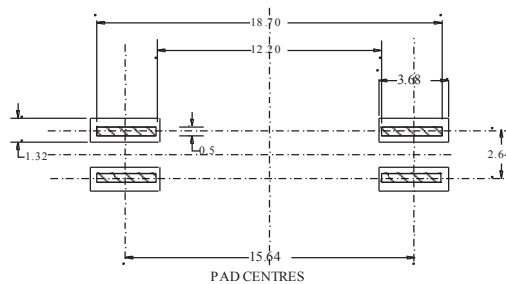

Packing

Waffle Trays - 100 per tray 290mm x 200mm.
 Tape & Reel - 400 Devices per 13" Diam Reel with 7" HuB 32mm Wide tape.

BEDFORD OPTO TECHNOLOGY LTD
1, BIGGAR BUSINESS PARK, BIGGAR, LANARKSHIRE, ML12 6FX
 Tel: +44 (0) 1899 221221 Fax: +44 (0) 1899 221009
 Website: bot.co.uk E-mail: bill@bot.co.uk



ADVISED SOLDERING CONDITIONS

IR Reflow soldering profile conforming to IPC9501

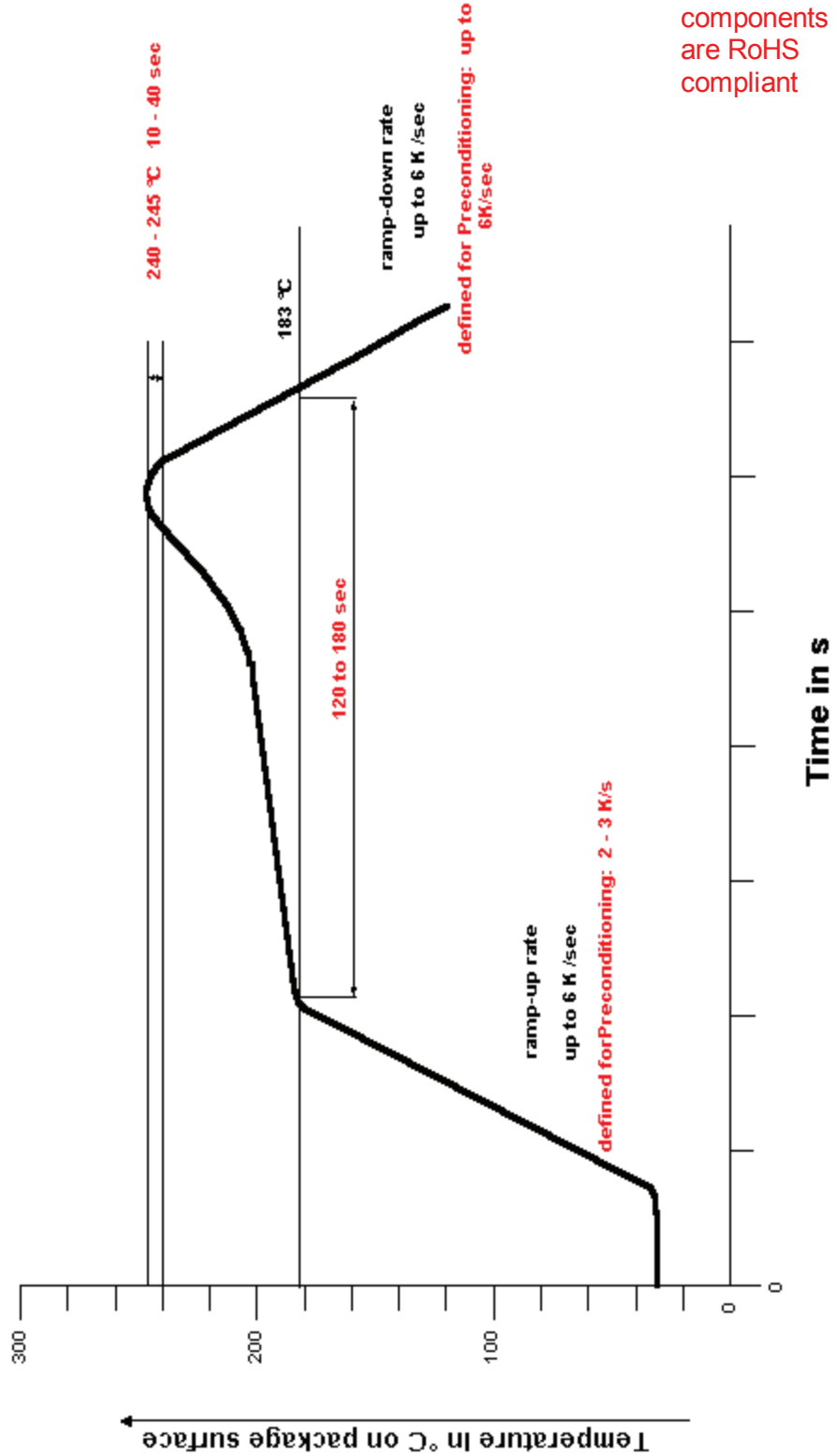

These components are RoHS compliant



BEDFORD OPTO TECHNOLOGY LTD
1, BIGGAR BUSINESS PARK, BIGGAR, LANARKSHIRE, ML12 6FX
Tel: +44 (0) 1899 221221 Fax: +44 (0) 1899 221009
Website: bot.co.uk E-mail: bill@bot.co.uk



These components are RoHS compliant



OPTO ELECTRONIC DATA (TA = 25°C)

PARAMETER	SYMBOL	MIN	TYP	MAX	UNITS	TEST CONDITIONS
<u>INPUT DIODE</u>						
Forward Voltage	V _F	-	-	1.3	V	I _f = 20mA
Reverse Voltage	V _R	5.0	-	-	V	I _r = 100uA
<u>OUTPUT TRANSISTOR</u>						
Collector-Emitter Breakdown Voltage	BV _{ceo}	35	-	-	V	I _c = 10 uA
Collector-Emitter Leakage Current	I _{ceo}	OPI1000IE OPI1000IA to D	-	10	nA	V _{ce} = 30 V
			-	100	nA	V _{ce} = 10 V
Emitter-Collector Breakdown	BV _{eco}	5.0	-	-	V	I _e = 100uA
<u>COUPLED PAIR</u>						
DC Current Transfer Ratio	I _c /I _f					
OPI 1000L A	-	25	-	-	%	I _f = 10 mA V _{ce} = 5 V
OPI 1000L B	-	50	-	-	%	I _f = 10 mA V _{ce} = 5 V
OPI 1000L C	-	100	-	-	%	I _f = 10 mA V _{ce} = 5 V
OPI 1000L E	-	40	-	-	%	I _f = 1mA V _{ce} = 5 V
Isolation Voltage	V _{ISO}	10	-	-	KV	-
Collector-emitter saturation Voltage	V _{CE(SAT)}	-	-	0.4	V	I _f = 10 mA, I _c = 1.6mA
Turn-on time	t _{on}	-	8	-	uS	I _c = 2mA
Turn-off time	t _{off}	-	8	-	uS	V _{ce} = 5V R _L = 100ohm

BEDFORD OPTO TECHNOLOGY LTD
1, BIGGAR BUSINESS PARK, BIGGAR, LANARKSHIRE, ML12 6FX
 Tel: +44 (0) 1899 221221 Fax: +44 (0) 1899 221009
 Website: bot.co.uk E-mail: bill@bot.co.uk



These components are RoHS compliant



SCHEDULE OF LIMITATIONS

EC TYPE EXAMINATION CERTIFICATE No. BAS01ATEX1278U/5

28th September 2012

SCHEDULE OF LIMITATIONS

- 1 - The Opto Isolator must be mounted on a p.c.b. having a CTI of at least 175 such that creepage and clearance distances are not impaired. i.e.:- on an uncoated printed circuit board that maintains at least 10mm in air.
- 2 - The Opto Isolator may be used to provide isolation between either:-
 - (i) A non-intrinsically safe circuit and an intrinsically safe circuit, (Non IS:IS), where the IS circuit voltage is not greater than 75 Volts peak or d.c..
 - OR
 - (ii) Two intrinsically safe circuits (IS:IS), where the sum of the two circuit voltages is not greater than 375 Volts peak or d.c..
- 3 - The Opto Isolator must be installed such that the connection pins are provided with a degree of protection of at least IP20 where gasses and vapours may be present. If the Opto Isolator is to be installed where dusts represent a hazard, then it must be provided with a degree of protection of at least IP54 and the overall apparatus must be Appropriately certified for the requirements for Dusts.
- 4 - The Opto Isolator must be installed with external power limiting components as specified in:- EN60079-11:2012, Clause 8.9.2.

CERTIFICATE No.:- IECEx BAS 06.0021U

Date of Issue:- 2012-10-02

ISSUE No.: 4

SCHEDULE OF LIMITATIONS

1. When used in intrinsically safe apparatus it will be necessary to determine a surface temperature classification for the opto-isolator:-
2. The Opto Isolator must be mounted on a printed circuit board such that creepage and clearance distances are not impaired.
3. The Opto Coupler must be installed such that the connection pins are provided with a degree of protection of IP20 where gasses and vapours may be present. If the Opto Coupler is to be installed within apparatus where flammable dusts represent the hazard then it must be provided with a degree of protection of IP54 and the apparatus must be appropriately certified for dust hazards.
5. The Opto Isolator must be installed with external power limiting components as specified in:- IEC60079-11:2011 Ed 6, Clause 8.9.2.

Opto-isolator type	Thermal resistivity °C/W
OPI110	77
OPI1000L	52
OPI1264	70
OPI2000M	87

BEDFORD OPTO TECHNOLOGY LTD
1,BIGGAR BUSINESS PARK, BIGGAR, LANARKSHIRE, ML12 6FX
 Tel: +44 (0) 1899 221221 Fax: +44 (0) 1899 221009
 Website: bot.co.uk E-mail: bill@bot.co.uk

CONFORMITY STATEMENT OPI1000L SERIES

This
component
is RoHS
compliant



Manufacturer:- BEDFORD OPTO TECHNOLOGY LTD

Address:- 1 Biggar Business Park, Market Road, Biggar,
Lanarkshire, ML12 6FX, Scotland.

Directive 94/9/EC

EC-Type Examination Certificate:-

BAS01ATEX1278U – Latest supplement BAS01ATEX1278U/5 issued **Sept. 2012**

Provisions of the Directive fulfilled by the component:-



Ex ia IIC Ga (-40°C ≤ Ta ≤ +85°C)

Ex ia IIIC Da (-40°C ≤ Ta ≤ +85°C)

Notified Body for EC-Type Examination & Production:- BASEEFA Ltd. – No.1180

BASEEFA Ltd.

Rockhead Business Park,

Staden Lane,

Buxton,

Derbyshire SK17 9RZ,

England

Tel:- +44 (0)1298 766600

Fax:- +44 (0)1298 766601

e-mail:- info@baseefa.com

Harmonised Standards used:-

EN60079-0:2012

EN60079-11:2012

EN60079-26:2007

Other Standards used:-

On Behalf of Bedford Opto Technology Ltd., I declare that, the date the component accompanied by this statement is placed on the market, the component conforms with all technical and regulatory requirements of the ATEX Directive 94/9/EC **and the RoHS Directive 2011/65/EU.**

Mr R.W.Stott
Managing Director

PP-