

Features

- Wide supply
 - Voltage range: 2.0V to 36V
 - Single or dual supplies: $\pm 1.0V$ to $\pm 18V$
- Very low supply current drain (0.4 mA) – independent of supply voltage
- Low input biasing current: 25 nA
- Low input offset current: ± 5 nA
- Maximum offset voltage: ± 3 mV
- Input common-mode voltage range includes ground
- Differential input voltage range equal to the power supply voltage
- Low output saturation voltage: 250 mV at 4 mA
- Output voltage compatible with TTL, DTL, ECL, MOS and CMOS logic systems
- Packages: 8-pin SOP-8L and DFN (Under Development) **Green** packages

Advantages

- High precision comparators
- Reduced V_{OS} drift over temperature
- Eliminates need for dual supplies
- Allows sensing near ground
- Compatible with all forms of logic
- Power drain suitable for battery operation

Pin Assignment

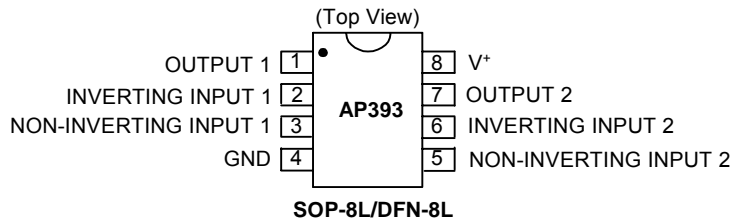

Pin Descriptions

Pin Name	Pin No.	Description
OUTPUT 1	1	Channel 1 Output
INVERTING INPUT 1	2	Channel 1 Negative Input
NON-INVERTING INPUT 1	3	Channel 1 Positive Input
GND	4	Ground

Pin Name	Pin No.	Description
NON-INVERTING INPUT 2	5	Channel 2 Positive Input
INVERTING INPUT 2	6	Channel 2 Negative Input
OUTPUT 2	7	Channel 2 Output
V ⁺	8	Vcc

Ordering Information (Note 1)

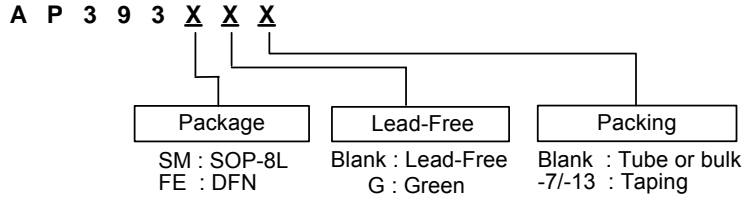

Device	Package Code	Packaging	7" Tape and Reel		13" Tape and Reel	
			Quantity	Part Number Suffix	Quantity	Part Number Suffix
AP393SM	SM	SOP-8L	3000/Tape & Reel	-7	10,000/Tape & Reel	-13
AP393FE	FE	DFN	3000/Tape & Reel	-7	10,000/Tape & Reel	-13

Block Diagram

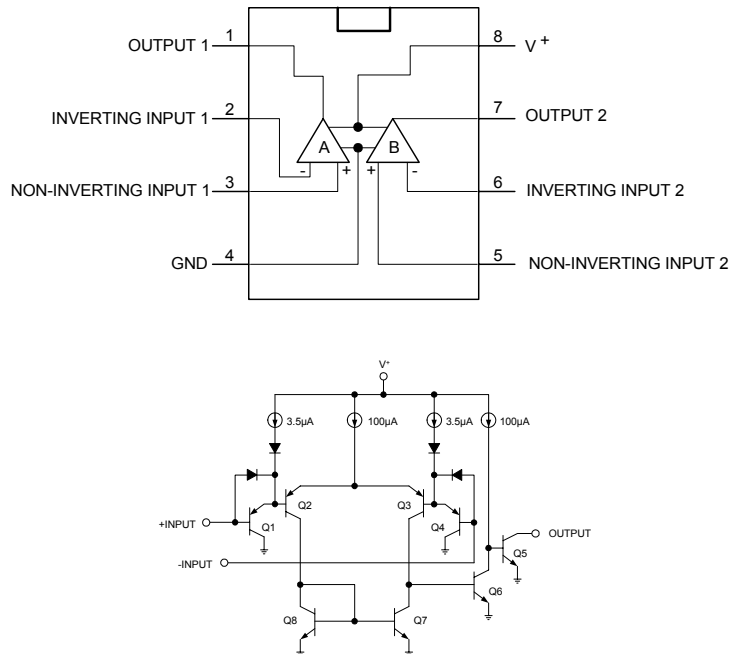

Note 1: For Packaging Details, go to our website at <http://www.diodes.com/datasheets/ap02007.pdf>.

Absolute Maximum Ratings (Note 11)

Symbol	Parameter	Rating	Unit		
V_{CC}	Supply Voltage	36	V		
V_{IN}	Differential Input Voltage (Note 9)	36	V		
V_{IN}	Input Voltage	-0.3 to +36	V		
I_{CC}	Input Current ($V_{IN}=0.3V$) (Note 4)	50	mA		
P_D	Power Dissipation (Note 2)	SOP-8L (SM)	600		
		DFN (FE)	250		
	Output Short-Circuit to Ground (Note 3)	Continuous			
T_{OP}	Operating Temperature Range	0 to +70	°C		
T_{ST}	Storage Temperature Range	-65 to +150	°C		
T_{Lead}	Lead Temperature Range (Soldering, 10 sec)	+260	°C		
	Soldering Information	DFN	Soldering (10 sec)	+260	°C
		SOP-8L	Vapor Phase (60 sec)	+215	
			Infrared (15 sec)	+220	
	ESD rating (1.5kΩ in with 100pF)	1300	V		

Electrical Characteristics ($V_{CC}=5V$, $T_A=25^\circ C$, unless otherwise stated)

Symbol	Parameter	Conditions	Min.	Typ.	Max.	Unit
V_{OFFSET}	Input Offset Voltage	(Note 10)	-	7.0	12.0	mV
I_{BIAS}	Input Bias Current	$I_{IN(+)}$ or $I_{IN(-)}$ with Output In Linear Range, $V_{CM}=0V$ (Note 6)	-	25	250	nA
I_{OFFSET}	Input Offset Current	$I_{IN(+)} - I_{IN(-)}$, $V_{CM}=0V$	-	5.0	50	nA
	Input Common Mode Voltage Range	$V^+ = 30V$ (Note 7)	0	-	$V^+ - 1.5$	V
I_{CC}	Supply Current	$R_L = \infty$	-	0.4	1	mA
		$V^+ = 5V$ $V^+ = 36V$	-	1	2.5	
	Voltage Gain	$R_L \geq 15k\Omega$, $V^+ = 15V$ $V_O = 1V$ to $11V$	50	200	-	V/mV
	Large Signal Response Time	V_{IN} =TTL Logic Swing, $V_{REF}=1.4V$, $V_{RL}=5V$, $R_L=5.1k\Omega$	-	300	-	ns
	Response Time	$V_{RL}=5V$, $R_L=5.1k\Omega$ (Note 8)	-	1.3	-	μs
$I_{O(SINK)}$	Output Sink Current	$V_{IN(-)}=1V$, $V_{IN(+)}=0$, $V_O < 1.5V$	6.0	16	-	mA
V_{SAT}	Saturation Voltage	$V_{IN(-)}=1V$, $V_{IN(+)}=0$, $I_{SINK} \leq 4mA$	-	250	400	mV
$I_{O(Leak)}$	Output Leakage Current	$V_{IN(-)}=0$, $V_{IN(+)}=1V$, $V_O=5V$	-	0.1	-	nA

Electrical Characteristics ($V_{CC}=5V$) (Note 5)

Symbol	Parameter	Conditions	Min.	Typ.	Max.	Unit
V_{OFFSET}	Input Offset Voltage	(Note 10)	-	-	12	mV
I_{OFFSET}	Input Offset Current	$I_{IN(+)} - I_{IN(-)}$, $V_{CM}=0V$	-	-	150	nA
I_{BIAS}	Input Bias Current	$I_{IN(+)}$ or $I_{IN(-)}$ with Output In Linear Range, $V_{CM}=0V$ (Note 6)	-	-	400	nA
	Input Common Mode Voltage Range	$V^+ = 30V$ (Note 7)	0	-	$V^+ - 2.0$	V
V_{SAT}	Saturation Voltage	$V_{IN(-)}=1V$, $V_{IN(+)}=0$, $I_{SINK} \leq 4mA$	-	-	700	mV
$I_{O(Leak)}$	Output Leakage Current	$V_{IN(-)}=0$, $V_{IN(+)}=1V$, $V_O=30V$	-	-	1.0	μA
	Differential Input Voltage	Keep All V_{IN} 's $\geq 0V$ (or V^+ , if Used), (Note 9)	-	-	36	V

- Note 2:** For operating at high temperatures, the AP393 must be derated based on a 125°C maximum junction temperature and a thermal resistance of 170°C/W which applies for the device soldered in a printed circuit board, operating in a still air ambient. The AP393 must be derated based on a 150°C maximum junction temperature. The low bias dissipation and the “ON-OFF” characteristic of the outputs keeps the chip dissipation very small ($P_D \leq 100$ mW), provided the output transistors are allowed to saturate.
- Note 3:** Short circuits from the output to V^+ can cause excessive heating and eventual destruction. When considering short circuits to ground, the maximum output current is approximately 20 mA independent of the magnitude of V^+ .
- Note 4:** This input current will only exist when the voltage at any of the input leads is driven negative. It is due to the collector-base junction of the input PNP transistors becoming forward biased and thereby acting as input diode clamps. In addition to this diode action, there is also lateral NPN parasitic transistor action on the IC chip. This transistor action can cause the output voltages of the comparators to go to the V^+ voltage level (or to ground for a large overdrive) for the time duration that an input is driven negative. This is not destructive and normal output states will re-establish when the input voltage, which is negative, again returns to a value greater than -0.3V.
- Note 5:** The AP393 temperature specifications are limited to $0^\circ\text{C} \leq T_A \leq +70^\circ\text{C}$.
- Note 6:** The direction of the input current is out of the IC due to the PNP input stage. This current is essentially constant, independent of the state of the output so no loading change exists on the reference or input lines.
- Note 7:** The input common-mode voltage or either input signal voltage should not be allowed to go negative by more than 0.3V. The upper end of the common-mode voltage range is $V^+ - 1.5\text{V}$ at 25°C, but either or both inputs can go to 36V without damage, independent of the magnitude of V^+ .
- Note 8:** The response time specified is for a 100 mV input step with 5 mV overdrive. For larger overdrive signals 300 ns can be obtained, see typical performance characteristics section.
- Note 9:** Positive excursions of input voltage may exceed the power supply level. As long as the other voltage remains within the common-mode range, the comparator will provide a proper output state. The low input voltage state must not be less than -0.3V (or 0.3V below the magnitude of the negative power supply, if used).
- Note 10:** At output switch point, $V_O \approx 1.4\text{V}$, $R_S = 0\Omega$ with V^+ from 5V to 30V; and over the full input common-mode range (0V to $V^+ - 1.5\text{V}$), at 25°C.
- Note 11:** Refer to RETS193AX for AP393 military specifications.

Typical Circuit ($V_{CC} = 5.0V_{DC}$)

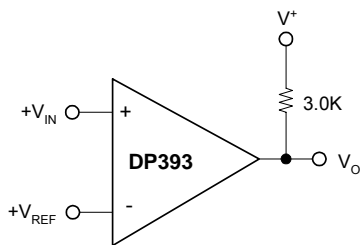

Basic Comparator

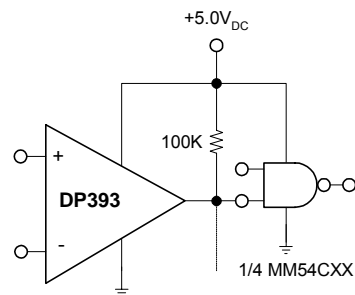

Driving CMOS

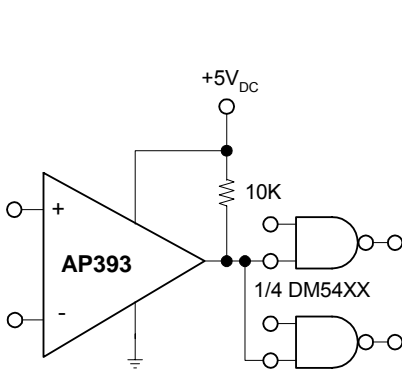

Driving TTL

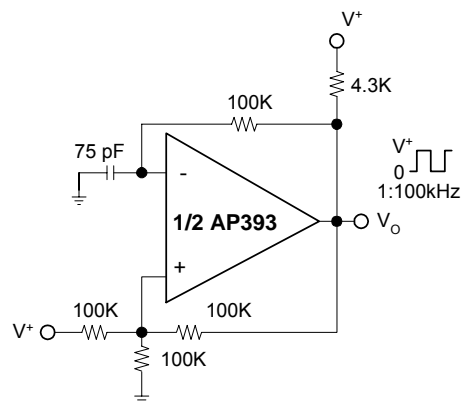

Squarewave Oscillator

Typical Circuit (Continued) ($V_{CC} = 5.0V_{DC}$)

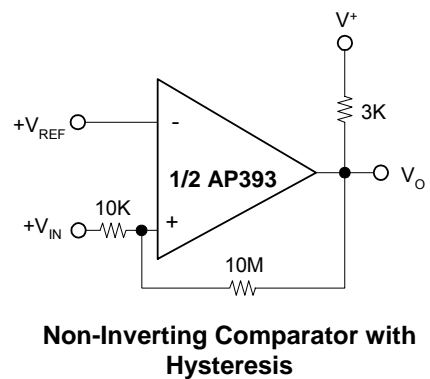
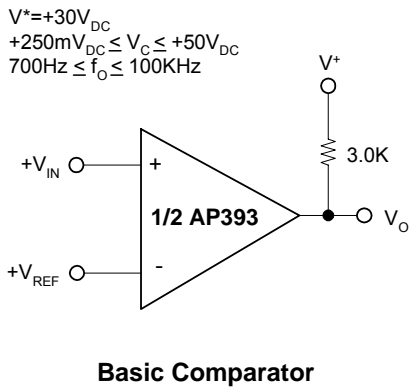
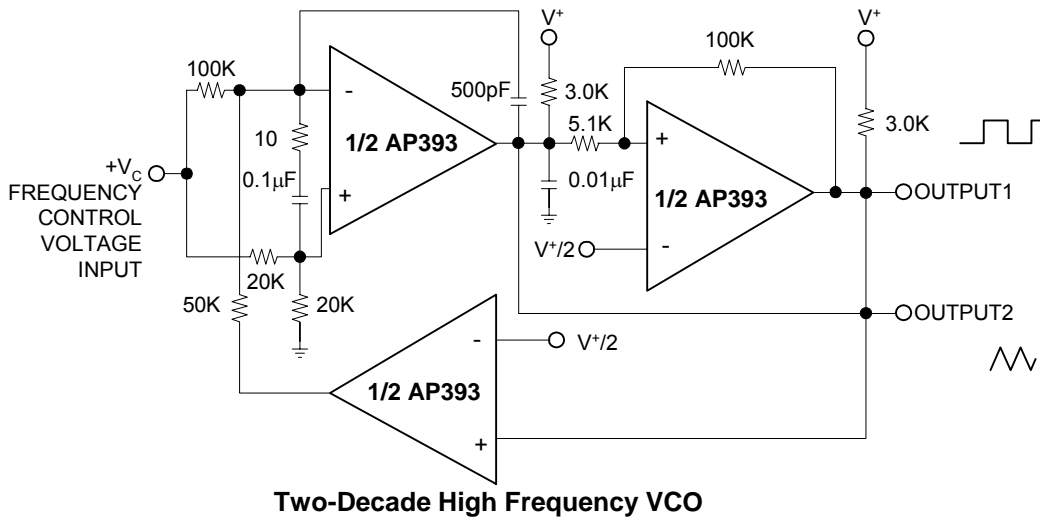
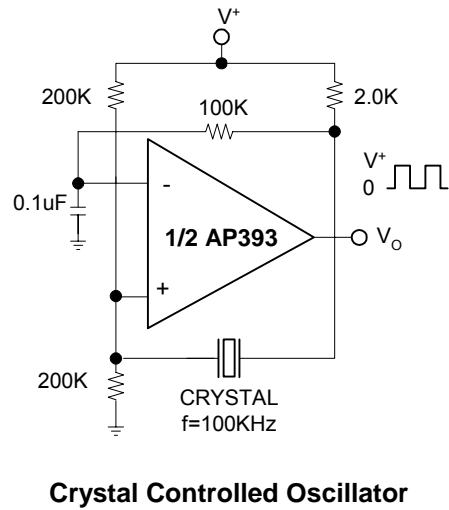
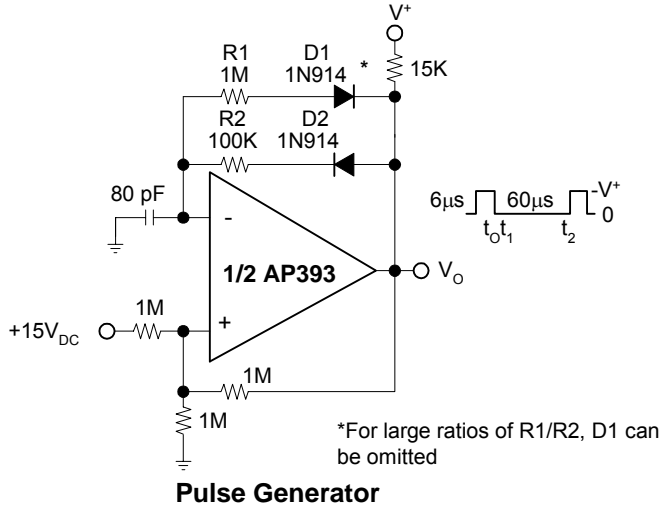

Typical Circuit (Continued) ($V_{CC} = 5.0V_{DC}$)

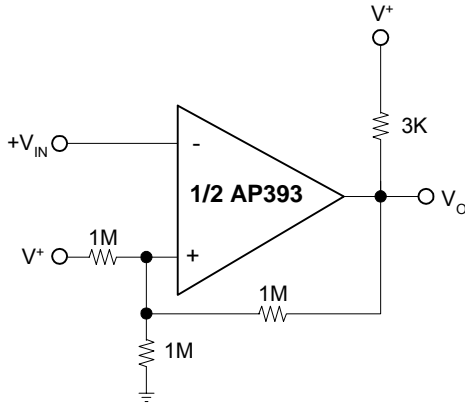

Inverting Comparator with Hysteresis

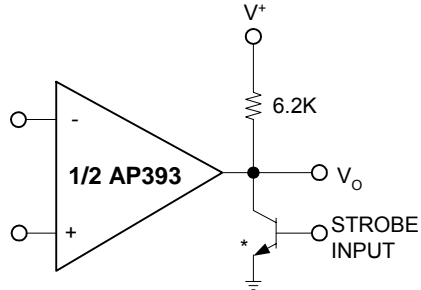

* OR LOGIC GATE WITHOUT PULL-UP RESISTOR

Output Strobing

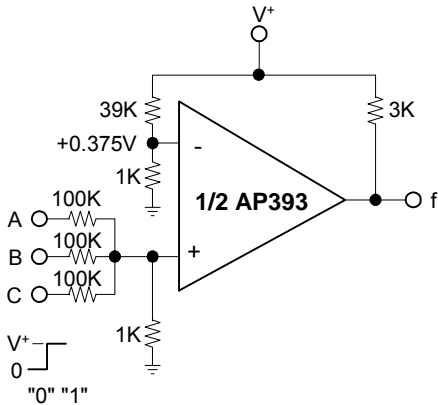

AND Gate

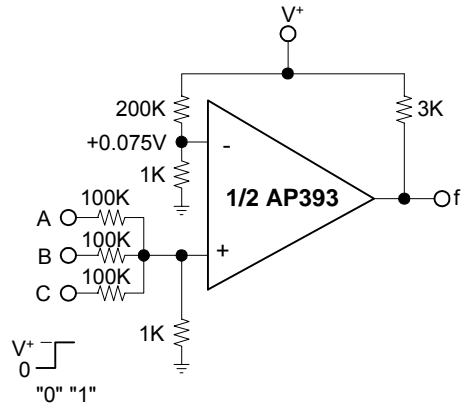

Or Gate

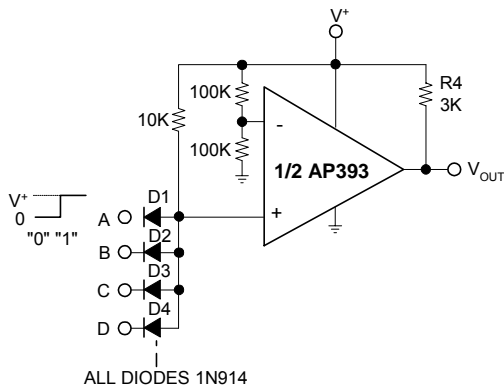

Large Fan-in AND Gate

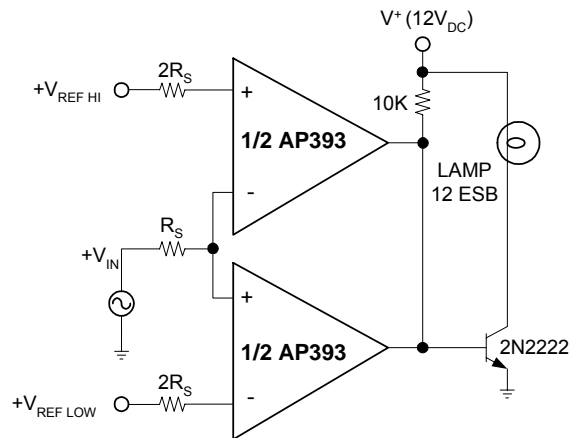

Limit Comparator

Typical Circuit (Continued) ($V_{CC} = 5.0V_{DC}$)

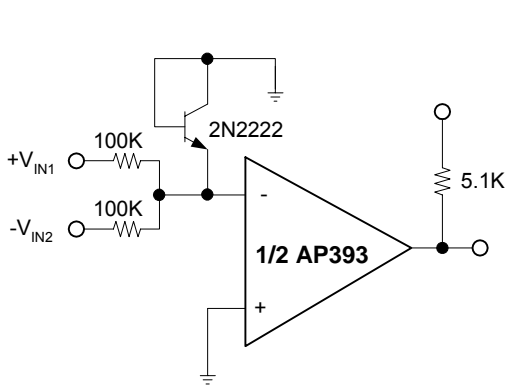

Comparing Input Voltages of Opposite Polarity

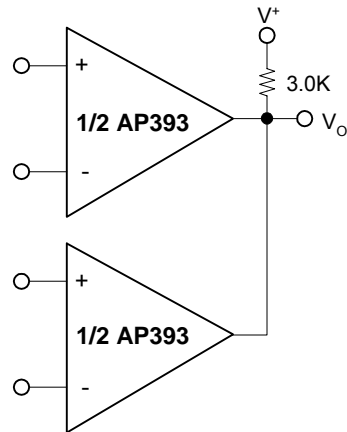

ORing the Outputs

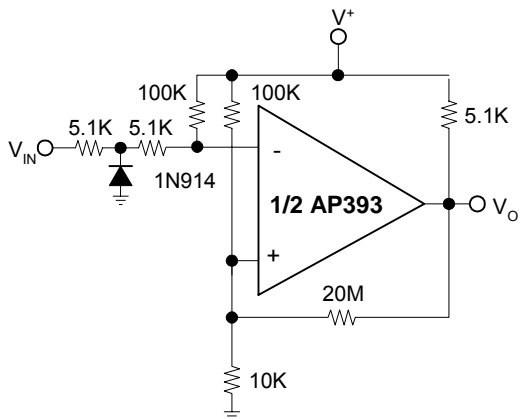

Zero Crossing Detector (Single Power Supply)

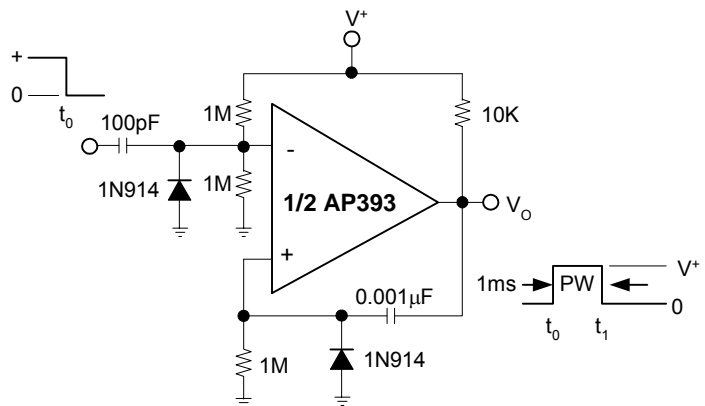

One-Shot Multivibrator

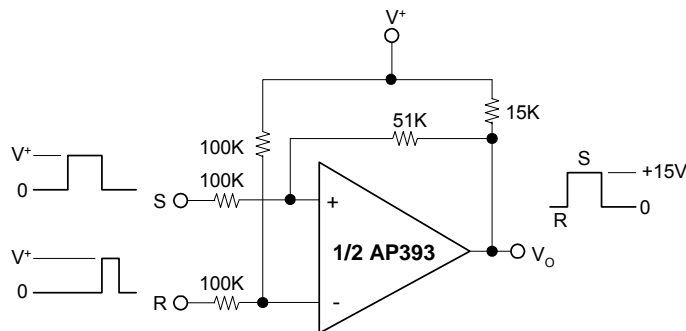

Bi-Stable Multivibrator

Typical Circuit (Continued) ($V_{CC} = 5.0V_{DC}$)

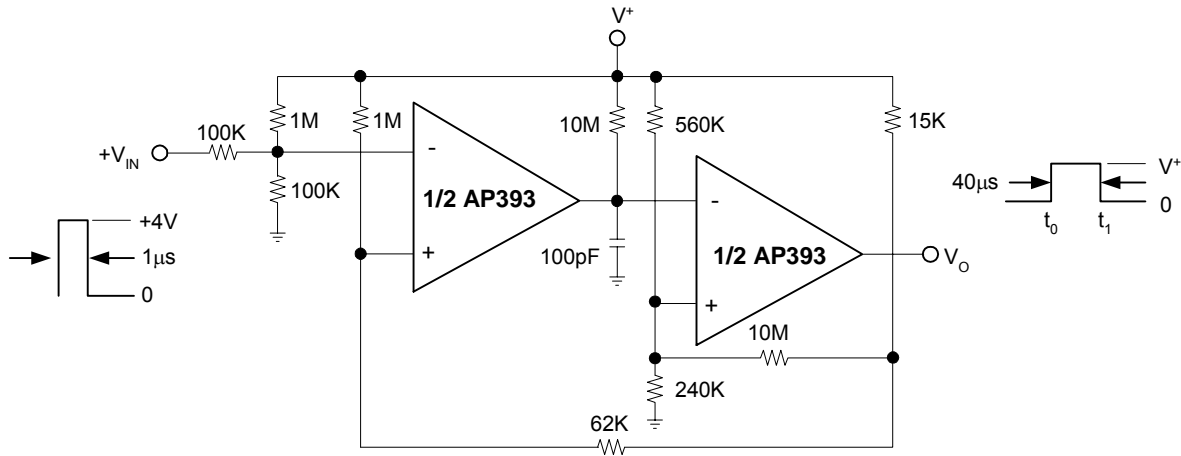

One-Shot Multivibrator with Input Lock Out

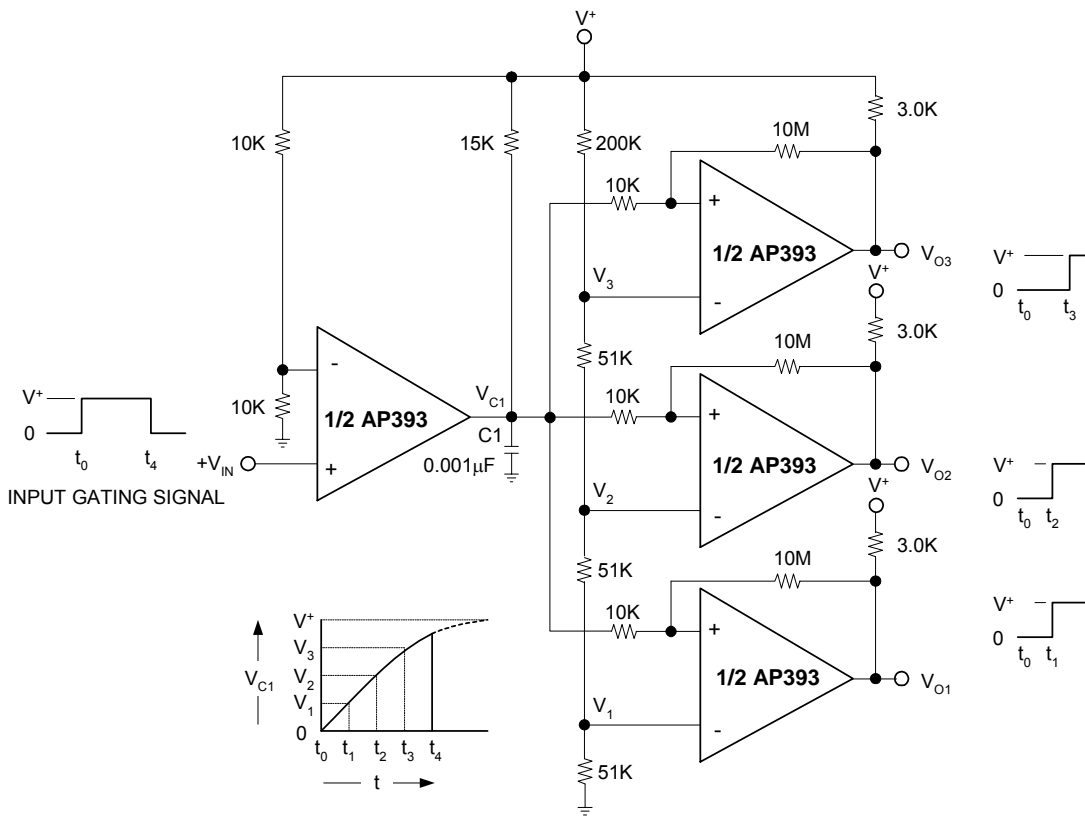

Time Delay Generator

Split-Supply Applications ($V^+ = +15V_{DC}$ and $V^- = -15V_{DC}$)

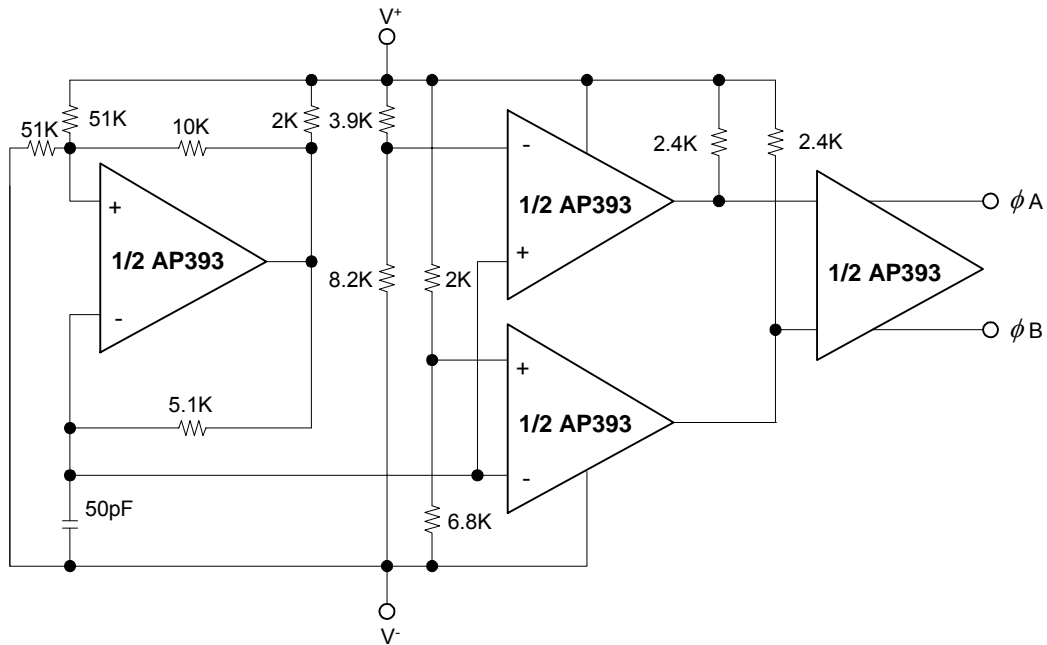

MOS Clock Driver

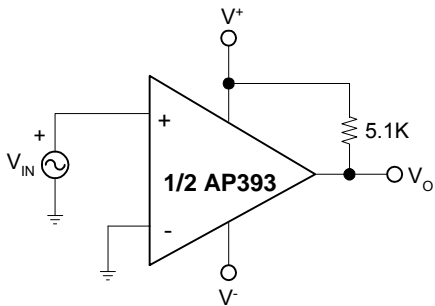

Zero Crossing Detector

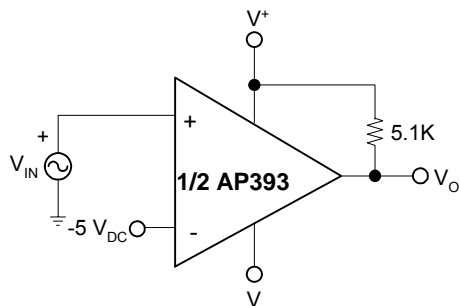

**Comparator With a
Negative Reference**

Typical Characteristics

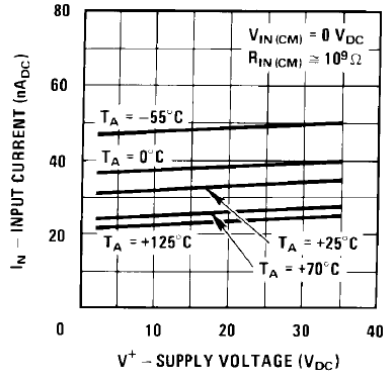

Supply Current

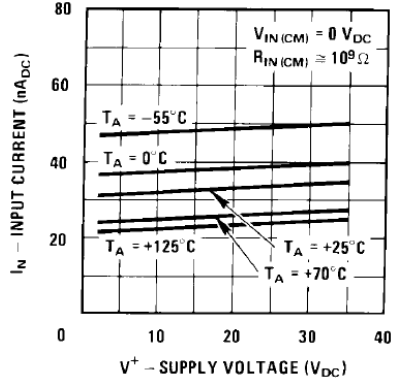

Input Current

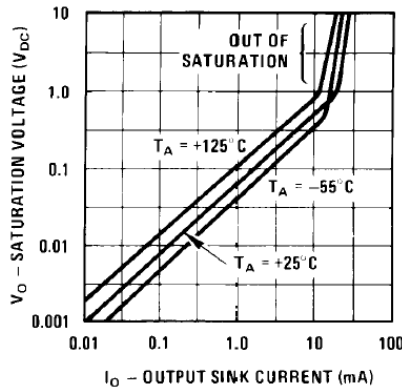

Output Saturation Voltage

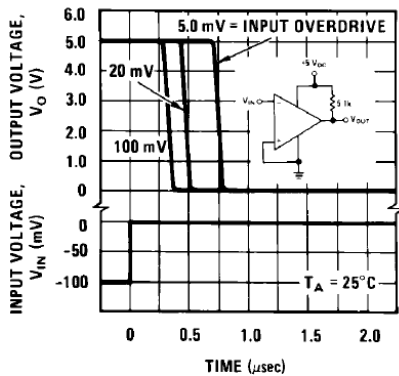

Response Time for Various Input Overdrives—Negative Transition

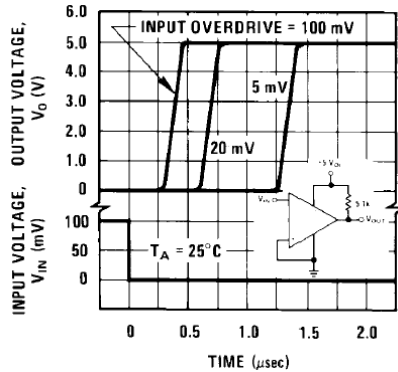

Response Time for Various Input Overdrives—Positive Transition

Application Information

The AP393 are high gain, wide bandwidth devices which, like most comparators, can easily oscillate if the output lead is inadvertently allowed to capacitively couple to the inputs via stray capacitance. This shows up only during the output voltage transition intervals as the comparator change states. Power supply bypassing is not required to solve this problem. Standard PC board layout is helpful as it reduces stray input-output coupling. Reducing the input resistors to $< 10k\Omega$ reduces the feedback signal levels and finally, adding even a small amount (1.0 to 10 mV) of positive feedback (hysteresis) causes such a rapid transition that oscillations due to stray feedback are not possible. Simply socketing the IC and attaching resistors to the pins will cause input-output oscillations during the small transition intervals unless hysteresis is used. If the input signal is a pulse waveform, with relatively fast rise and fall times, hysteresis is not required. All input pins of any unused comparators should be tied to the negative supply.

The bias network of the AP393 establishes a drain current which is independent of the magnitude of the power supply voltage over the range of from $2.0 V_{DC}$ to $30 V_{DC}$. It is usually unnecessary to use a bypass capacitor across the power supply line.

The differential input voltage may be larger than $V+$ without damaging the device (Note 8). Protection should be provided to

prevent the input voltages from going negative more than $-0.3 V_{DC}$ (at $25^{\circ}C$). An input clamp diode can be used as shown in the applications section.

The output of the AP393 is the uncommitted collector of a grounded-emitter NPN output transistor. Many collectors can be tied together to provide an output OR'ing function. An output pull-up resistor can be connected to any available power supply voltage within the permitted supply voltage range and there is no restriction on this voltage due to the magnitude of the voltage which is applied to the $V+$ terminal of the AP393 package. The output can also be used as a simple SPST switch to ground (when a pull-up resistor is not used). The amount of current which the output device can sink is limited by the drive available (which is independent of $V+$) and the β of this device. When the maximum current limit is reached (approximately 16mA), the output transistor will come out of saturation and the output voltage will rise very rapidly. The output saturation voltage is limited by the approximately $60\Omega r_{SAT}$ of the output transistor. The low offset voltage of the output transistor (1.0 mV) allows the output to clamp essentially to ground level for small load currents.

Marking Information

(1) SOP-8L

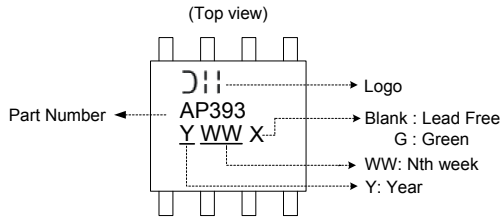

(2) DFN

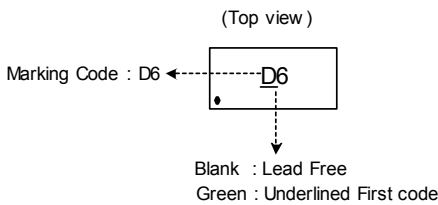

Marking Code Table

Device	Package	Marking Code	Date Code
AP393SM	SOP-8L	AP393	YWW
AP393FE	DFN	D6	-

Date Code Key

Year	2006	2007	2008	2009	2010
Code	T	U	V	W	X

Month	Jan	Feb	March	Apr	May	Jun	Jul	Aug	Sep	Oct	Nov	Dec
Code	1	2	3	4	5	6	7	8	9	O	N	D

IMPORTANT NOTICE

Diodes, Inc. and its subsidiaries reserve the right to make changes without further notice to any product herein to make corrections, modifications, enhancements, improvements, or other changes. Diodes, Inc. does not assume any liability arising out of the application or use of any product described herein; neither does it convey any license under its patent rights, nor the rights of others. The user of products in such applications shall assume all risks of such use and will agree to hold Diodes Incorporated and all the companies whose products are represented on our website, harmless against all damages.

LIFE SUPPORT

The products located on our website at www.diodes.com are not recommended for use in life support systems where a failure or malfunction of the component may directly threaten life or cause injury without the expressed written approval of Diodes Incorporated.