

MAX803 Series, NCP803 Series

Very Low Supply Current 3-Pin Microprocessor Reset Monitor

The MAX803/NCP803 is a cost-effective system supervisor circuit designed to monitor V_{CC} in digital systems and provide a reset signal to the host processor when necessary. No external components are required.

The reset output is driven active within 10 μ sec of V_{CC} falling through the reset voltage threshold. Reset is maintained active for a timeout period which is trimmed by the factory after V_{CC} rises above the reset threshold. The MAX803/NCP803 has an open drain active-low $\overline{\text{RESET}}$ output. Both devices are available in SOT-23 and SC-70 packages.

The MAX803/NCP803 is optimized to reject fast transient glitches on the V_{CC} line. Low supply current of 0.5 μ A ($V_{CC} = 3.2$ V) make these devices suitable for battery powered applications.

Features

- Precision V_{CC} Monitor for 1.5 V, 2.5 V, 3.0 V, 3.3 V, and 5.0 V Supplies
- Precision Monitoring Voltages from 1.2 V to 4.9 V Available in 100 mV Steps
- Four Guaranteed Minimum Power-On Reset Pulse Width Available (1 ms, 20 ms, 100 ms, and 140 ms)
- $\overline{\text{RESET}}$ Output Guaranteed to $V_{CC} = 1.0$ V
- Low Supply Current
- V_{CC} Transient Immunity
- No External Components
- Wide Operating Temperature: -40°C to 105°C
- These Devices are Pb-Free and are RoHS Compliant

Typical Applications

- Computers
- Embedded Systems
- Battery Powered Equipment
- Critical Microprocessor Power Supply Monitoring

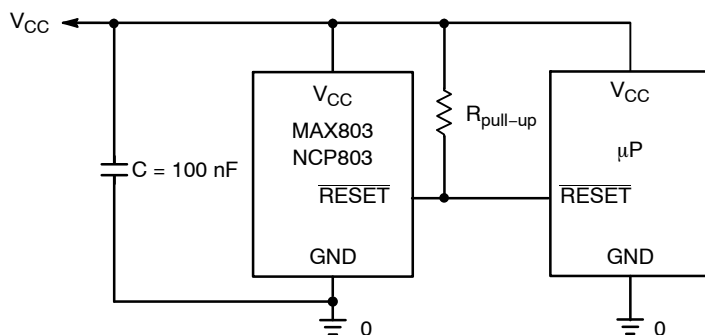

Figure 1. Typical Application Diagram



ON Semiconductor®

<http://onsemi.com>

MARKING DIAGRAM

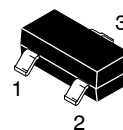

SOT-23
(TO-236)
CASE 318

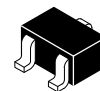
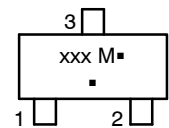

SC-70
(SOT-323)
CASE 419

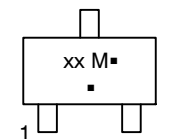

xxx = Specific Device Code
M = Date Code
▪ = Pb-Free Package

(Note: Microdot may be in either location)

PIN CONFIGURATION

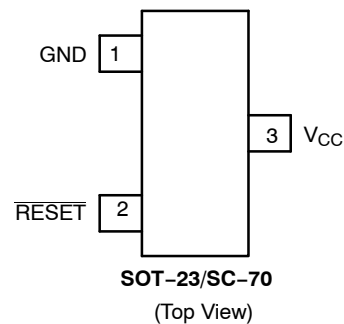

ORDERING INFORMATION

See detailed ordering and shipping information in the package dimensions section on page 8 of this data sheet.

DEVICE MARKING INFORMATION

See general marking information in the device marking section on page 8 of this data sheet.

MAX803 Series, NCP803 Series

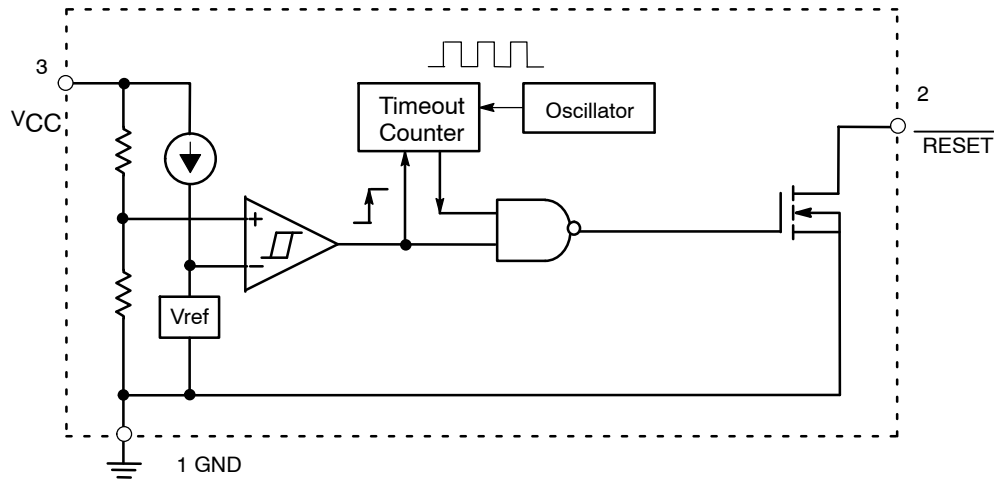

Figure 2. NCP803, MAX803 Series Open-Drain Active-Low Output

PIN DESCRIPTION

Pin No.	Symbol	Description
1	GND	Ground
2	RESET	RESET output remains low while V_{CC} is below the reset voltage threshold, and for a reset timeout period after V_{CC} rises above reset threshold.
3	V_{CC}	Supply Voltage: C = 100 nF is recommended as a bypass capacitor between V_{CC} and GND.

ABSOLUTE MAXIMUM RATINGS

Rating	Symbol	Value	Unit
Power Supply Voltage (V_{CC} to GND)	V_{CC}	-0.3 to 6.0	V
RESET Output Voltage (CMOS)		-0.3 to ($V_{CC} + 0.3$)	V
Input Current, V_{CC}		20	mA
Output Current, RESET		20	mA
dV/dt (V_{CC})		100	V/ μ sec
Thermal Resistance, Junction-to-Air (Note 1)	SOT-23 SC-70 $R_{\theta JA}$	301 314	$^{\circ}$ C/W
Operating Junction Temperature Range	T_J	-40 to +105	$^{\circ}$ C
Storage Temperature Range	T_{stg}	-65 to +150	$^{\circ}$ C
Lead Temperature (Soldering, 10 Seconds)	T_{sol}	+260	$^{\circ}$ C
ESD Protection			V
Human Body Model (HBM): Following Specification JESD22-A114		2000	
Machine Model (MM): Following Specification JESD22-A115		200	
Latchup Current Maximum Rating: Following Specification JESD78 Class II	$I_{Latchup}$		mA
Positive		200	
Negative		200	

Stresses exceeding Maximum Ratings may damage the device. Maximum Ratings are stress ratings only. Functional operation above the Recommended Operating Conditions is not implied. Extended exposure to stresses above the Recommended Operating Conditions may affect device reliability.

- This is based on a 35x35x1.6mm FR4 PCB with 10mm² of 1 oz copper traces under natural convection conditions and a single component characterization.
- The maximum package power dissipation limit must not be exceeded.

$$P_D = \frac{T_{J(max)} - T_A}{R_{\theta JA}} \quad \text{with } T_{J(max)} = 150^{\circ}\text{C}$$

MAX803 Series, NCP803 Series

ELECTRICAL CHARACTERISTICS $T_A = -40^{\circ}\text{C}$ to $+105^{\circ}\text{C}$ unless otherwise noted. Typical values are at $T_A = +25^{\circ}\text{C}$. (Note 3)

Characteristic	Symbol	Min	Typ	Max	Unit
V_{CC} Range $T_A = 0^{\circ}\text{C}$ to $+70^{\circ}\text{C}$ $T_A = -40^{\circ}\text{C}$ to $+105^{\circ}\text{C}$		1.0 1.2	– –	5.5 5.5	V
Supply Current $V_{CC} = 3.3\text{ V}$ $T_A = -40^{\circ}\text{C}$ to $+85^{\circ}\text{C}$ $T_A = 85^{\circ}\text{C}$ to $+105^{\circ}\text{C}$ $V_{CC} = 5.5\text{ V}$ $T_A = -40^{\circ}\text{C}$ to $+85^{\circ}\text{C}$ $T_A = 85^{\circ}\text{C}$ to $+105^{\circ}\text{C}$	I_{CC}	– – – –	0.5 – 0.8 –	1.2 2.0 1.8 2.5	μA
Reset Threshold (V_{in} Decreasing) (Note 4) MAX803SQ463/NCP803SN463 $T_A = +25^{\circ}\text{C}$ $T_A = -40^{\circ}\text{C}$ to $+85^{\circ}\text{C}$ $T_A = +85^{\circ}\text{C}$ to $+105^{\circ}\text{C}$ MAX803SQ438/NCP803SN438 $T_A = +25^{\circ}\text{C}$ $T_A = -40^{\circ}\text{C}$ to $+85^{\circ}\text{C}$ $T_A = +85^{\circ}\text{C}$ to $+105^{\circ}\text{C}$ NCP803SN400 $T_A = +25^{\circ}\text{C}$ $T_A = -40^{\circ}\text{C}$ to $+85^{\circ}\text{C}$ $T_A = +85^{\circ}\text{C}$ to $+105^{\circ}\text{C}$ MAX803SQ308/NCP803SN308 $T_A = +25^{\circ}\text{C}$ $T_A = -40^{\circ}\text{C}$ to $+85^{\circ}\text{C}$ $T_A = +85^{\circ}\text{C}$ to $+105^{\circ}\text{C}$ MAX803SQ293/NCP803SN293 $T_A = +25^{\circ}\text{C}$ $T_A = -40^{\circ}\text{C}$ to $+85^{\circ}\text{C}$ $T_A = +85^{\circ}\text{C}$ to $+105^{\circ}\text{C}$ NCP803SN263 $T_A = +25^{\circ}\text{C}$ $T_A = -40^{\circ}\text{C}$ to $+85^{\circ}\text{C}$ $T_A = +85^{\circ}\text{C}$ to $+105^{\circ}\text{C}$ NCP803SN232 $T_A = +25^{\circ}\text{C}$ $T_A = -40^{\circ}\text{C}$ to $+85^{\circ}\text{C}$ $T_A = +85^{\circ}\text{C}$ to $+105^{\circ}\text{C}$ NCP803SN160 $T_A = +25^{\circ}\text{C}$ $T_A = -40^{\circ}\text{C}$ to $+85^{\circ}\text{C}$ $T_A = +85^{\circ}\text{C}$ to $+105^{\circ}\text{C}$ MAX803SN120, MAX803SQ120 $T_A = +25^{\circ}\text{C}$ $T_A = -40^{\circ}\text{C}$ to $+85^{\circ}\text{C}$ $T_A = +85^{\circ}\text{C}$ to $+105^{\circ}\text{C}$	V_{TH}	4.56 4.51 4.40 4.31 4.27 4.16 3.94 3.90 3.80 3.04 3.00 2.92 2.89 2.85 2.78 2.59 2.55 2.50 2.29 2.26 2.20 1.58 1.56 1.52 1.18 1.17 1.14	4.63 – – 4.38 – – 4.00 – – 3.08 – – 2.93 – – 2.63 – – 2.32 – – 1.60 – – 1.20 – –	4.70 4.75 4.88 4.45 4.49 4.60 4.06 4.10 4.20 3.11 3.15 3.23 2.96 3.00 3.08 2.66 2.70 2.76 2.35 2.38 2.45 1.62 1.64 1.68 1.22 1.23 1.26	V
Detector Voltage Threshold Temperature Coefficient		–	30	–	ppm/ $^{\circ}\text{C}$
V_{CC} to Reset Delay $V_{CC} = V_{TH}$ to $(V_{TH} - 100\text{ mV})$		–	10	–	μsec
Reset Active TimeOut Period (Note 5) MAX803SN(Q)293D1 MAX803SN(Q)293D2/MAX803SN(Q)308D2 MAX803SN(Q)293D3 MAX803SN(Q)293	t_{RP}	1.0 20 100 140	– – – –	3.3 66 330 460	msec
RESET Output Voltage Low $V_{CC} = V_{TH} - 0.2\text{ V}$ $1.6\text{ V} \leq V_{TH} \leq 2.0\text{ V}$, $I_{SINK} = 0.5\text{ mA}$ $2.1\text{ V} \leq V_{TH} \leq 4.0\text{ V}$, $I_{SINK} = 1.2\text{ mA}$ $4.1\text{ V} \leq V_{TH} \leq 4.9\text{ V}$, $I_{SINK} = 3.2\text{ mA}$	V_{OL}	–	–	0.3	V
RESET Leakage Current $V_{CC} > V_{TH}$, RESET De-asserted	I_{LEAK}	–	–	1	μA

3. Production testing done at $T_A = 25^{\circ}\text{C}$, over temperature limits guaranteed by design.

4. Contact your ON Semiconductor sales representative for other threshold voltage options.

5. Contact your ON Semiconductor sales representative for timeout options availability for other threshold voltage options.

MAX803 Series, NCP803 Series

TYPICAL OPERATING CHARACTERISTICS

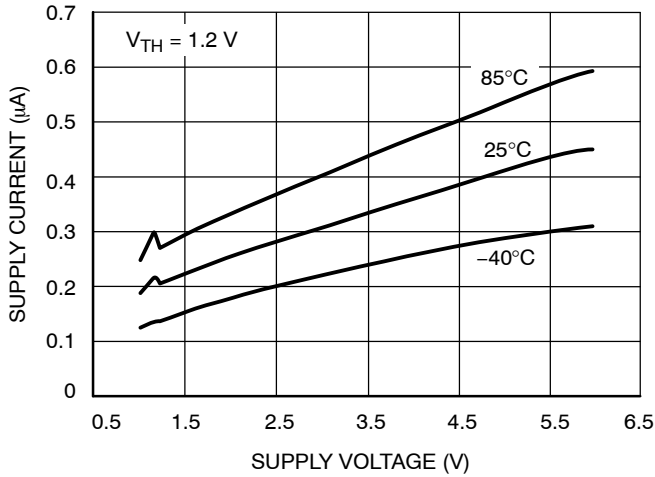

Figure 3. Supply Current vs. Supply Voltage

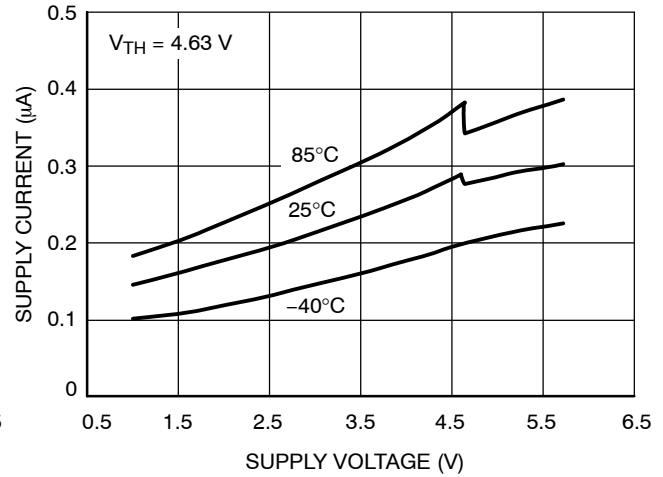

Figure 4. Supply Current vs. Supply Voltage

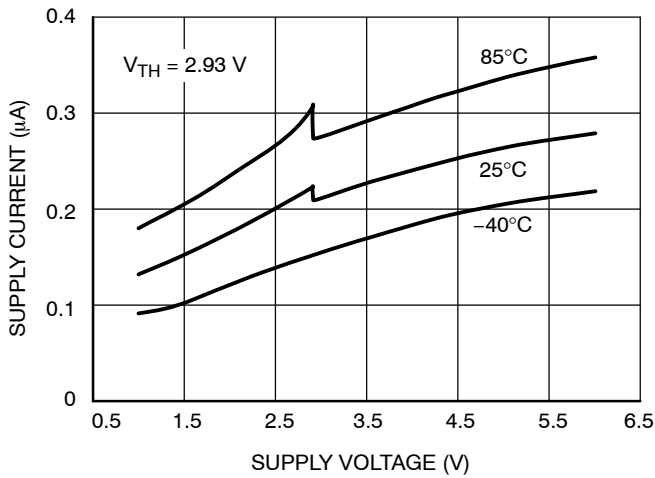

Figure 5. Supply Current vs. Supply Voltage

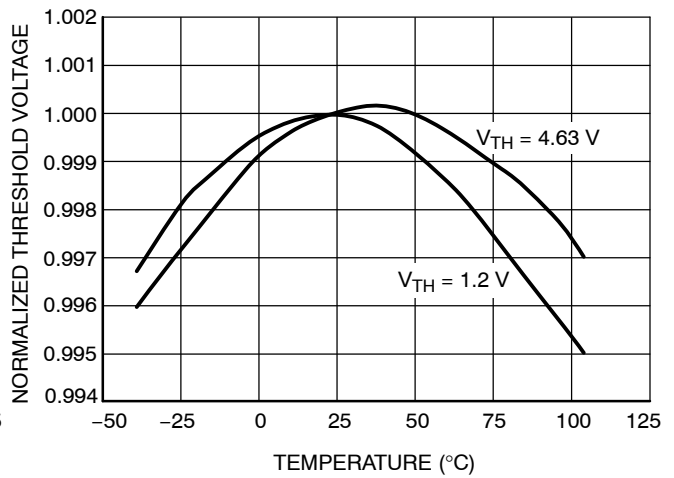

Figure 6. Normalized Reset Threshold Voltage vs. Temperature

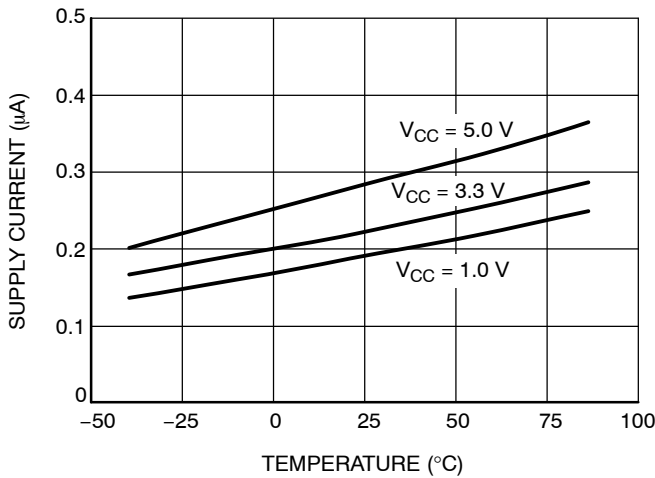

Figure 7. Supply Current vs. Temperature

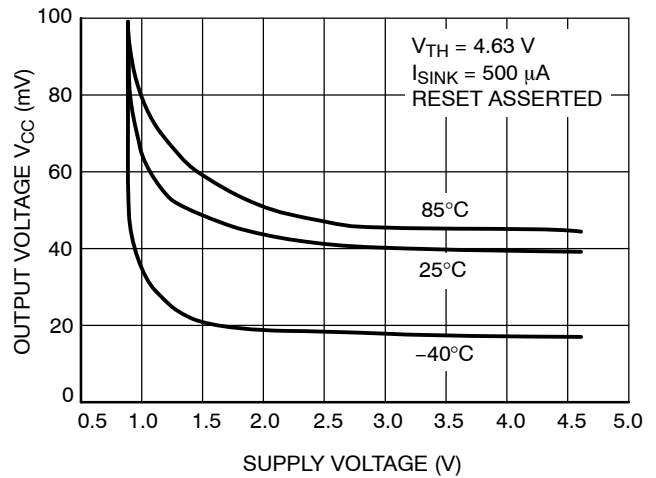

Figure 8. Output Voltage Low vs. Supply Voltage

MAX803 Series, NCP803 Series

TYPICAL OPERATING CHARACTERISTICS

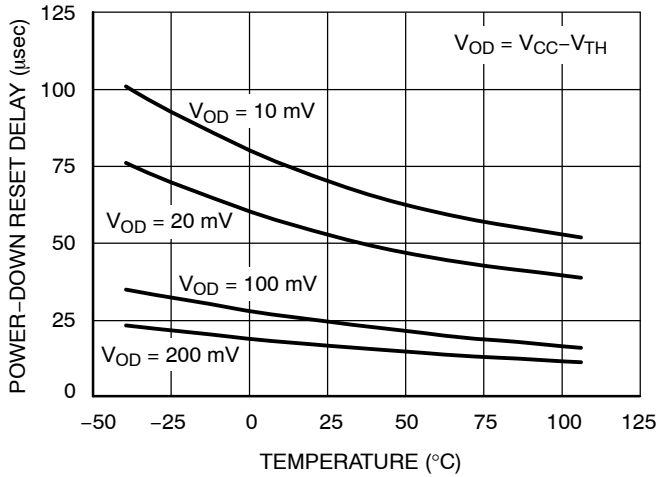

Figure 9. Power-Down Reset Delay vs. Temperature and Overdrive ($V_{TH} = 1.2\text{ V}$)

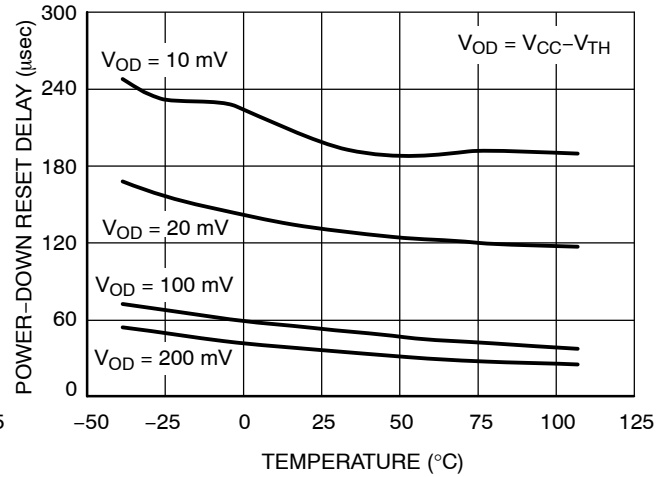

Figure 10. Power-Down Reset Delay vs. Temperature and Overdrive ($V_{TH} = 4.63\text{ V}$)

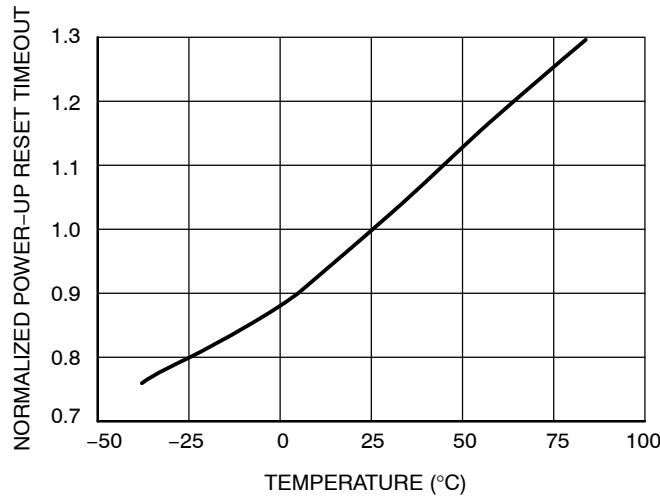

Figure 11. Normalized Power-Up Reset vs. Temperature

MAX803 Series, NCP803 Series

Detail Operation Description

The MAX803, NCP803 series microprocessor reset supervisory circuits are designed to monitor the power supplies in digital systems and provide a reset signal to the processor without any external components. Figure 2 shows the timing diagram and a typical application below. Initially consider that input voltage V_{CC} is at a nominal level greater than the voltage detector upper threshold (V_{TH}). And the $\overline{\text{RESET}}$ (RESET) output voltage (Pin 2) will be in the high state for MAX803 and NCP803 devices. If there is an input

power interruption and V_{CC} becomes significantly deficient, it will fall below the lower detector threshold (V_{TH-}). This event causes the RESET output to be in the low state for the MAX803 and NCP803 devices. After completion of the power interruption, V_{CC} will rise to its nominal level and become greater than the V_{TH} . This sequence activates the internal oscillator circuitry and digital counter to count. After the count of the timeout period, the reset output will revert back to the original state.

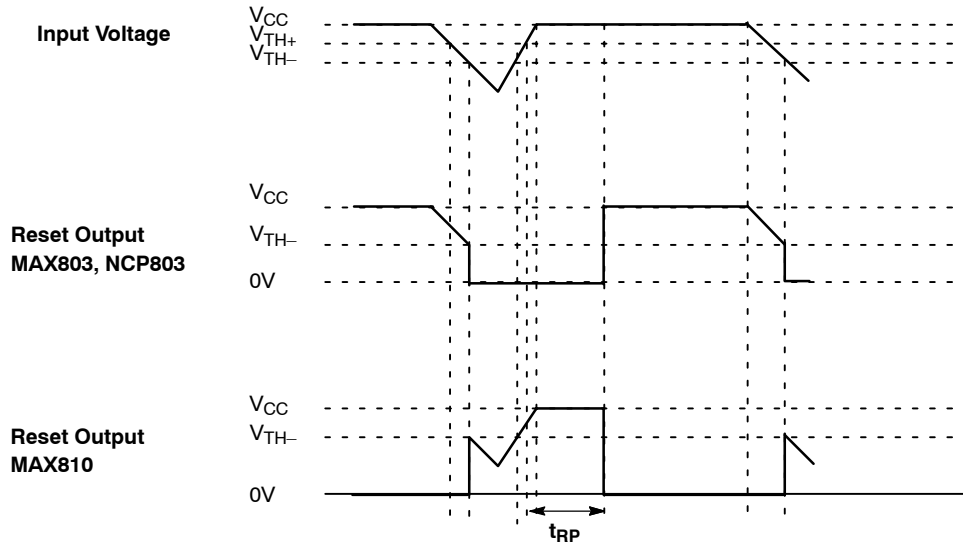

Figure 12. Timing Waveforms

APPLICATIONS INFORMATION

V_{CC} Transient Rejection

The MAX803/NCP803 series provides accurate V_{CC} monitoring and reset timing during power-up, power-down, and brownout/sag conditions, and rejects negative-going transients (glitches) on the power supply line. Figure 13 shows the maximum transient duration vs. maximum negative excursion (overdrive) for glitch rejection. Any combination of duration and overdrive which lies under the curve will not generate a reset signal. Combinations above the curve are detected as a brownout or power-down. Typically, transient that goes 100 mV below the reset threshold and lasts 5.0 μs or less will not cause a reset pulse. Transient immunity can be improved by adding a capacitor in close proximity to the V_{CC} pin of the MAX803.

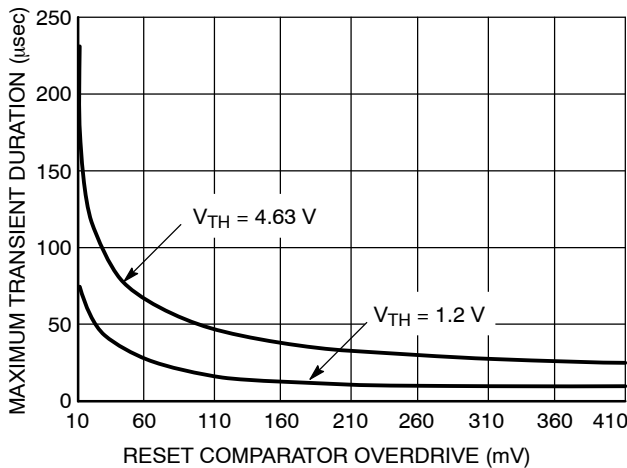
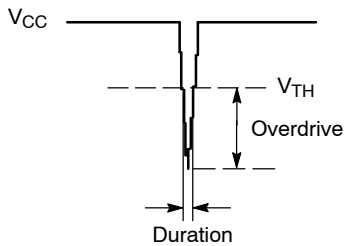
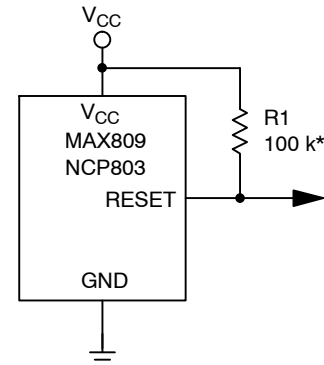

Figure 13. Maximum Transient Duration vs. Overdrive for Glitch Rejection at 25°C

RESET Signal Integrity During Power-Down

The MAX803/NCP803 RESET output is valid to V_{CC} = 1.0 V. Below this voltage the output becomes an “open circuit” and does not sink current. This means CMOS logic inputs to the Microprocessor will be floating at an undetermined voltage. Most digital systems are completely shutdown well above this voltage. However, in situations where RESET must be maintained valid to V_{CC} = 0 V, since

the NCP803/MAX803 has Open-Drain and active-low output, it typically uses a pullup resistor. With this device, RESET will most likely not maintain an active condition, but will drift to a non-active level due to the pullup resistor and the reduced sinking capability of the open-drain device. Therefore, this device is not recommended for applications where the RESET pin is required to be valid down to V_{CC} = 0 V.



*Assume High-Z Reset Input to Microprocessor

Figure 14. RESET Signal Integrity

MAX803 RESET Output Allows Use With Two Power Supplies

In numerous applications the pullup resistor place on the RESET output is connected to the supply voltage monitored by the IC. Nevertheless, a different supply voltage can also power this output and so level-shift from the monitored supply to reset the microprocessor. However, if the NCP803/MAX803's supply goes below 1 V, the RESET output ability to sink current will decrease and the result is a high state on the pin even though the supply's IC is under the threshold level. This occurs at a V_{CC} level that depends on the R_{pullup} value and the voltage which is connected.

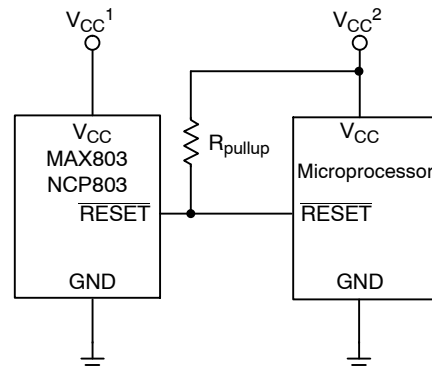

Figure 15. MAX803 RESET Output with Two Supplies

MAX803 Series, NCP803 Series

ORDERING, MARKING AND THRESHOLD INFORMATION

Part Number	Vth** (V)	Time out*** (ms)	Description	Marking	Package	Shipping
NCP803SN160T1G	1.60	140-460	Open Drain $\overline{\text{RESET}}$	SCQ	SOT23-3 (Pb-Free)	3000 / Tape & Reel
NCP803SN232T1G	2.32	140-460		SQR	SOT23-3 (Pb-Free)	
NCP803SN263T1G	2.63	140-460		SQC	SOT23-3 (Pb-Free)	
NCP803SN293T1G	2.93	140-460		SQD	SOT23-3 (Pb-Free)	
NCP803SN308T1G	3.08	140-460		SQE	SOT23-3 (Pb-Free)	
NCP803SN400T1G	4.00	140-460		RAD	SOT23-3 (Pb-Free)	
NCP803SN438T1G	4.38	140-460		SQF	SOT23-3 (Pb-Free)	
NCP803SN463T1G	4.63	140-460		SQG	SOT23-3 (Pb-Free)	
NCP803SN120T1G	1.20	140-460		SSW	SOT23-3 (Pb-Free)	
NCP803SN293D1T1G	2.93	1-3.3		SSX	SOT23-3 (Pb-Free)	
NCP803SN293D2T1G	2.93	20-66		SSY	SOT23-3 (Pb-Free)	
NCP803SN293D3T1G	2.93	100-330		SSZ	SOT23-3 (Pb-Free)	
MAX803SQ120T1G	1.20	140-460		ZV	SC70-3 (Pb-Free)	
MAX803SQ263T1G	2.63	140-460		SX	SC70-3 (Pb-Free)	
MAX803SQ293T1G	2.93	140-460		ZW	SC70-3 (Pb-Free)	
MAX803SQ308T1G	3.08	140-460		ZX	SC70-3 (Pb-Free)	
NCV803SQ308T1G*		140-460		ZA	SC70-3 (Pb-Free)	
MAX803SQ438T1G	4.38	140-460		ZY	SC70-3 (Pb-Free)	
MAX803SQ463T1G	4.63	140-460		ZZ	SC70-3 (Pb-Free)	
MAX803SQ293D1T1G	2.93	1-3.3		YA	SC70-3 (Pb-Free)	
MAX803SQ293D2T1G	2.93	20-66		YB	SC70-3 (Pb-Free)	
MAX803SQ308D2T1G	3.08	20-66		SY	SC70-3 (Pb-Free)	
NCV803SQ308D2T1G*		20-66		CY	SC70-3 (Pb-Free)	
MAX803SQ293D3T1G	2.93	100-330		YC	SC70-3 (Pb-Free)	

*NCV Prefix for Automotive and Other Applications Requiring Unique Site and Control Change Requirements; AEC-Q100 Qualified and PPAP Capable.

**Contact your ON Semiconductor sales representative for other threshold voltage options.

***Contact your ON Semiconductor sales representative for timeout options availability for other threshold voltage options.

MAX803 Series, NCP803 Series

PACKAGE DIMENSIONS

SOT-23 (TO236)
CASE 318-08
ISSUE AP

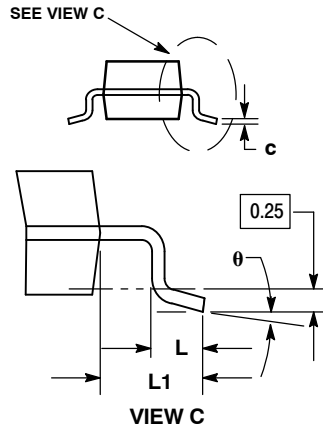
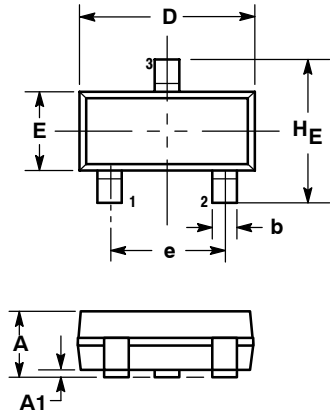

NOTES:

1. DIMENSIONING AND TOLERANCING PER ANSI Y14.5M, 1982.
2. CONTROLLING DIMENSION: INCH.
3. MAXIMUM LEAD THICKNESS INCLUDES LEAD FINISH THICKNESS. MINIMUM LEAD THICKNESS IS THE MINIMUM THICKNESS OF BASE MATERIAL.
4. DIMENSIONS D AND E DO NOT INCLUDE MOLD FLASH, PROTRUSIONS, OR GATE BURRS.

DIM	MILLIMETERS			INCHES		
	MIN	NOM	MAX	MIN	NOM	MAX
A	0.89	1.00	1.11	0.035	0.040	0.044
A1	0.01	0.06	0.10	0.001	0.002	0.004
b	0.37	0.44	0.50	0.015	0.018	0.020
c	0.09	0.13	0.18	0.003	0.005	0.007
D	2.80	2.90	3.04	0.110	0.114	0.120
E	1.20	1.30	1.40	0.047	0.051	0.055
e	1.78	1.90	2.04	0.070	0.075	0.081
L	0.10	0.20	0.30	0.004	0.008	0.012
L1	0.35	0.54	0.69	0.014	0.021	0.029
HE	2.10	2.40	2.64	0.083	0.094	0.104
θ	0°	---	10°	0°	---	10°

SOLDERING FOOTPRINT

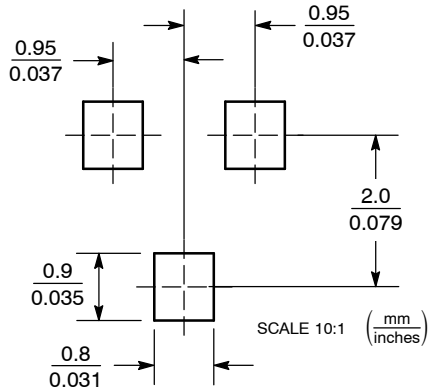

MAX803 Series, NCP803 Series

PACKAGE DIMENSIONS

SC-70 (SOT-323)
CASE 419-04
ISSUE N

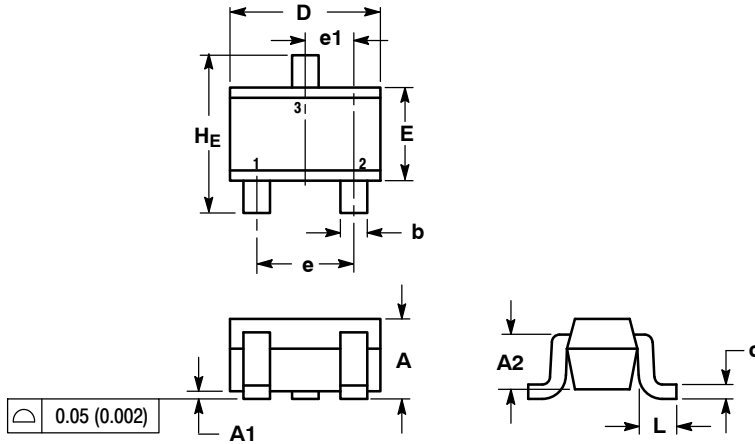

NOTES:

1. DIMENSIONING AND TOLERANCING PER ANSI Y14.5M, 1982.
2. CONTROLLING DIMENSION: INCH.

DIM	MILLIMETERS			INCHES		
	MIN	NOM	MAX	MIN	NOM	MAX
A	0.80	0.90	1.00	0.032	0.035	0.040
A1	0.00	0.05	0.10	0.000	0.002	0.004
A2	0.70 REF			0.028 REF		
b	0.30	0.35	0.40	0.012	0.014	0.016
c	0.10	0.18	0.25	0.004	0.007	0.010
D	1.80	2.10	2.20	0.071	0.083	0.087
E	1.15	1.24	1.35	0.045	0.049	0.053
e	1.20	1.30	1.40	0.047	0.051	0.055
e1	0.65 BSC			0.026 BSC		
L	0.20	0.38	0.56	0.008	0.015	0.022
HE	2.00	2.10	2.40	0.079	0.083	0.095

SOLDERING FOOTPRINT*

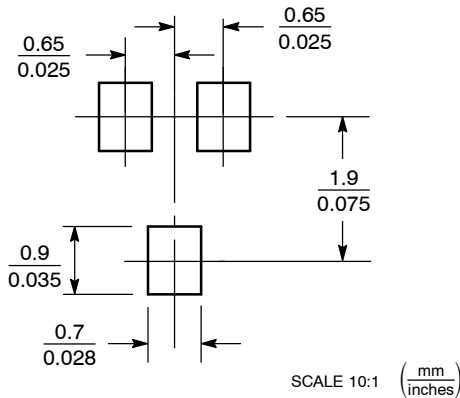

*For additional information on our Pb-Free strategy and soldering details, please download the ON Semiconductor Soldering and Mounting Techniques Reference Manual, SOLDERRM/D.

ON Semiconductor and  are registered trademarks of Semiconductor Components Industries, LLC (SCILLC). SCILLC owns the rights to a number of patents, trademarks, copyrights, trade secrets, and other intellectual property. A listing of SCILLC's product/patent coverage may be accessed at www.onsemi.com/site/pdf/Patent-Marking.pdf. SCILLC reserves the right to make changes without further notice to any products herein. SCILLC makes no warranty, representation or guarantee regarding the suitability of its products for any particular purpose, nor does SCILLC assume any liability arising out of the application or use of any product or circuit, and specifically disclaims any and all liability, including without limitation special, consequential or incidental damages. "Typical" parameters which may be provided in SCILLC data sheets and/or specifications can and do vary in different applications and actual performance may vary over time. All operating parameters, including "Typicals" must be validated for each customer application by customer's technical experts. SCILLC does not convey any license under its patent rights nor the rights of others. SCILLC products are not designed, intended, or authorized for use as components in systems intended for surgical implant into the body, or other applications intended to support or sustain life, or for any other application in which the failure of the SCILLC product could create a situation where personal injury or death may occur. Should Buyer purchase or use SCILLC products for any such unintended or unauthorized application, Buyer shall indemnify and hold SCILLC and its officers, employees, subsidiaries, affiliates, and distributors harmless against all claims, costs, damages, and expenses, and reasonable attorney fees arising out of, directly or indirectly, any claim of personal injury or death associated with such unintended or unauthorized use, even if such claim alleges that SCILLC was negligent regarding the design or manufacture of the part. SCILLC is an Equal Opportunity/Affirmative Action Employer. This literature is subject to all applicable copyright laws and is not for resale in any manner.

PUBLICATION ORDERING INFORMATION

LITERATURE FULFILLMENT:
Literature Distribution Center for ON Semiconductor
P.O. Box 5163, Denver, Colorado 80217 USA
Phone: 303-675-2175 or 800-344-3860 Toll Free USA/Canada
Fax: 303-675-2176 or 800-344-3867 Toll Free USA/Canada
Email: orderlit@onsemi.com

N. American Technical Support: 800-282-9855 Toll Free
USA/Canada
Europe, Middle East and Africa Technical Support:
Phone: 421 33 790 2910
Japan Customer Focus Center
Phone: 81-3-5817-1050

ON Semiconductor Website: www.onsemi.com
Order Literature: <http://www.onsemi.com/orderlit>

For additional information, please contact your local Sales Representative