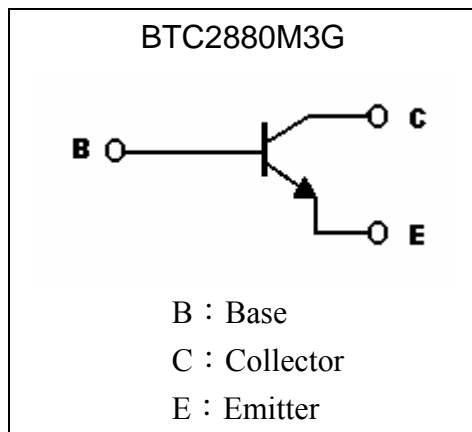
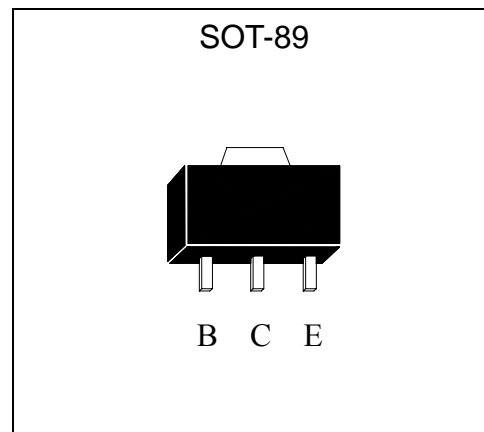

General Purpose NPN Epitaxial Planar Transistor

BTC2880M3G

Features

- High breakdown voltage, $BV_{CEO} \geq 120V$
- Large continuous collector current capability
- Low collector saturation voltage
- RoHS compliant and Halogen-free package

Symbol

Outline

Absolute Maximum Ratings ($T_a=25^\circ C$)

Parameter	Symbol	Limits	Unit
Collector-Base Voltage	V_{CBO}	180	V
Collector-Emitter Voltage	V_{CEO}	120	V
Emitter-Base Voltage	V_{EBO}	7	V
Collector Current	I_C	1	A
Base Current	I_B	2	A
Power Dissipation	P_d	0.6	W
		1 (Note 1)	W
		2 (Note 2)	W
Junction Temperature	T_j	150	$^\circ C$
Storage Temperature	T_{stg}	-55~+150	$^\circ C$

 Note : 1. When mounted on FR-4 PCB with area measuring $10 \times 10 \times 1$ mm

 2. When mounted on ceramic with area measuring $40 \times 40 \times 1$ mm

**Characteristics (Ta=25°C)**

Symbol	Min.	Typ.	Max.	Unit	Test Conditions
BV _{CBO}	180	-	-	V	I _C =50μA
BV _{CEO}	120	-	-	V	I _C =1mA
BV _{EBO}	7	-	-	V	I _E =50μA
I _{CBO}	-	-	100	nA	V _{CB} =180V
I _{EBO}	-	-	100	nA	V _{EB} =6V
*V _{CE(sat)}	-	0.1	0.2	V	I _C =500mA, I _B =50mA
*V _{CE(sat)}	-	0.2	0.5	V	I _C =1A, I _B =50mA
*V _{BE(sat)}	-	-	1	V	I _C =500mA, I _B =50mA
*V _{BE(on)}	-	-	0.9	V	V _{CE} =5V, I _C =500mA
*h _{FE 1}	100	-	-	-	V _{CE} =5V, I _C =50mA
*h _{FE 2}	100	-	270	-	V _{CE} =5V, I _C =100mA
*h _{FE 3}	80	-	-	-	V _{CE} =5V, I _C =800mA
f _T	50	-	-	MHz	V _{CE} =10V, I _C =50mA, f=100MHz
C _{ob}	-	-	20	pF	V _{CB} =10V, I _E =0A, f=1MHz

*Pulse Test: Pulse Width ≤380μs, Duty Cycle ≤2%

Classification Of hFE 2

Rank	P	Q
Range	100~200	120~270

Ordering Information

Device	Package	Shipping	Marking
BTC2880M3G	SOT-89 (RoHS Compliant and Halogen-free package)	1000 pcs / Tape & Reel	CB

Characteristic Curves

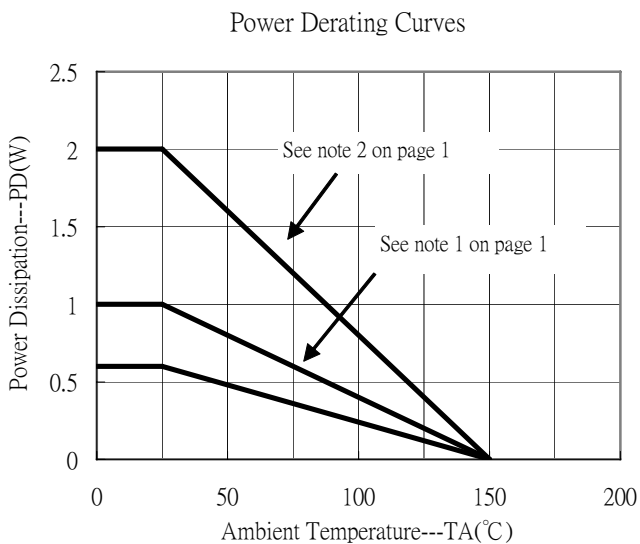
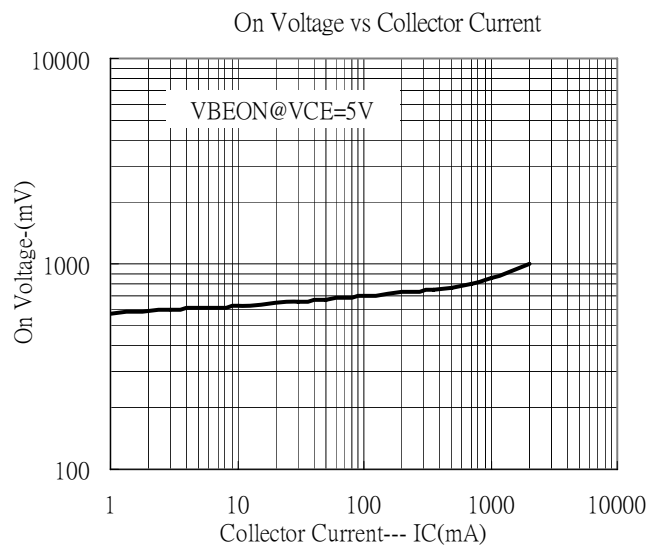
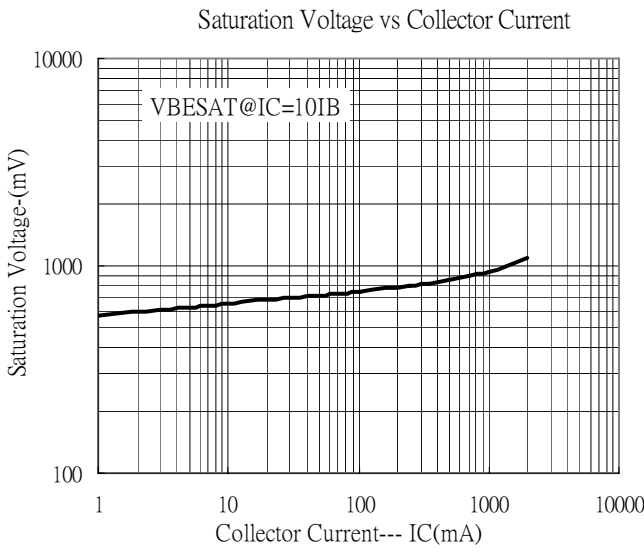
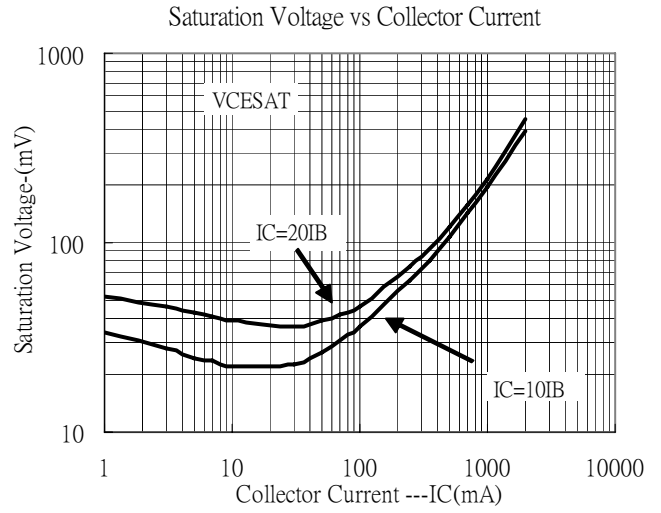
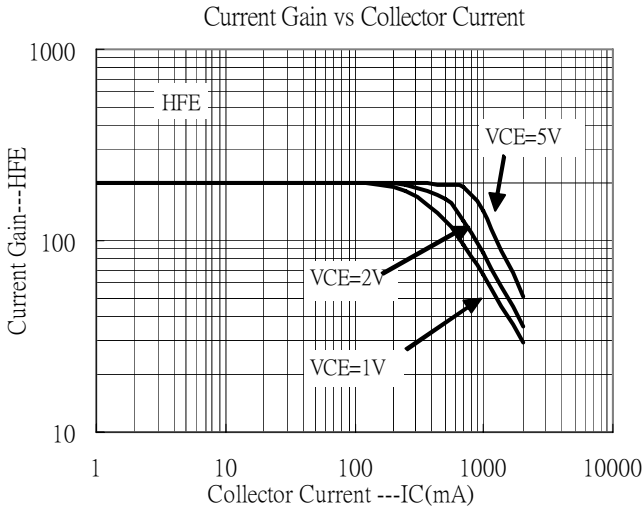

Reel Dimension

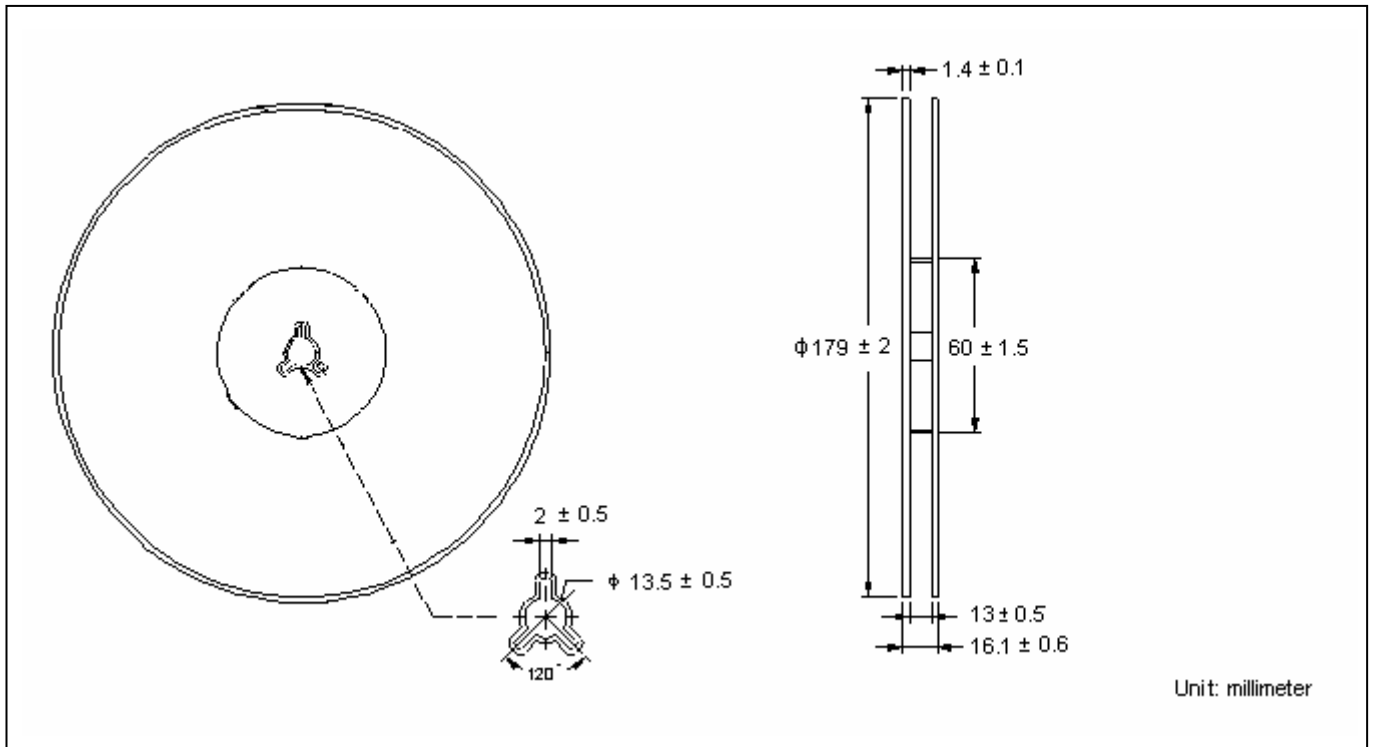

Carrier Tape Dimension

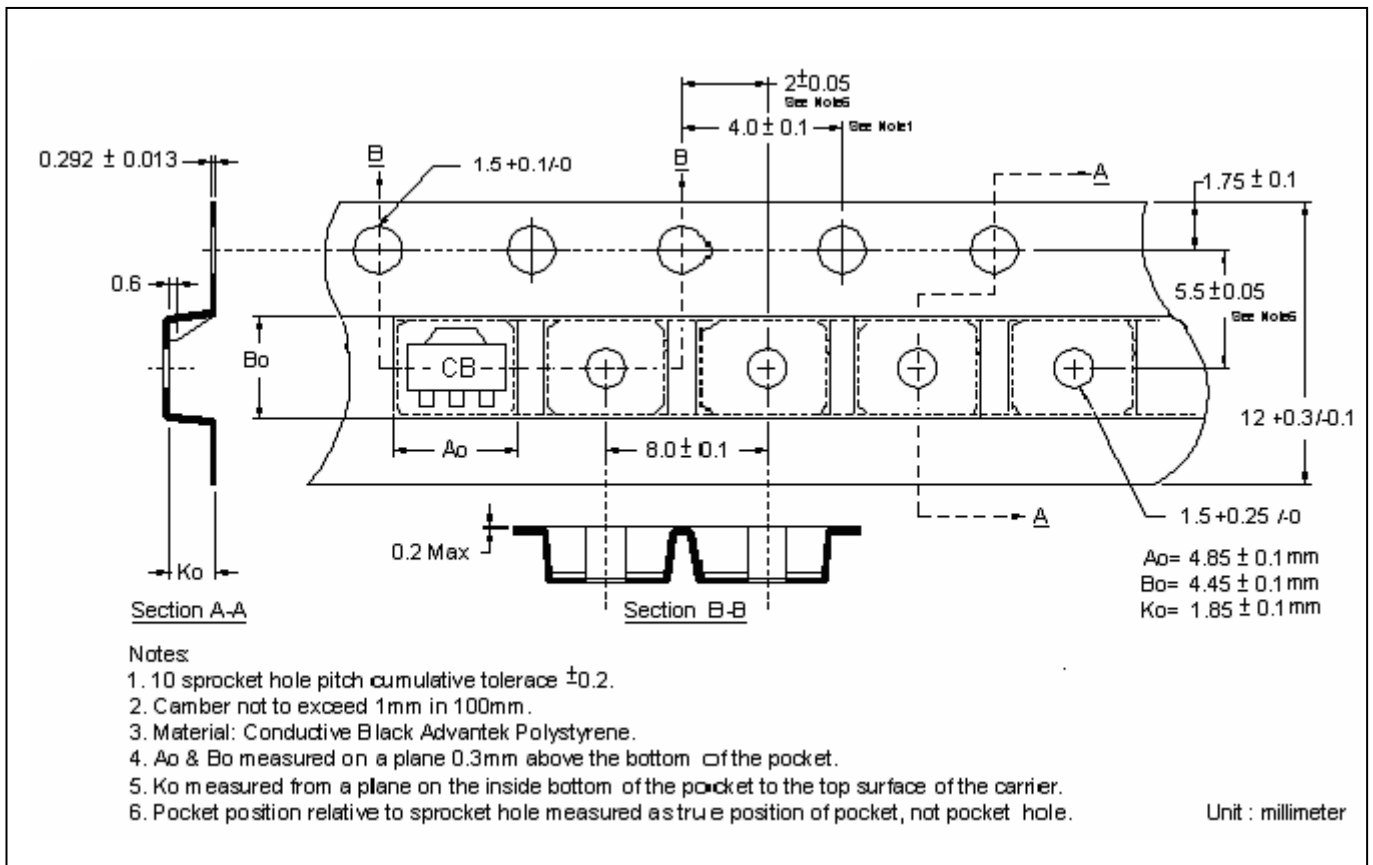

SOT-89 Dimension

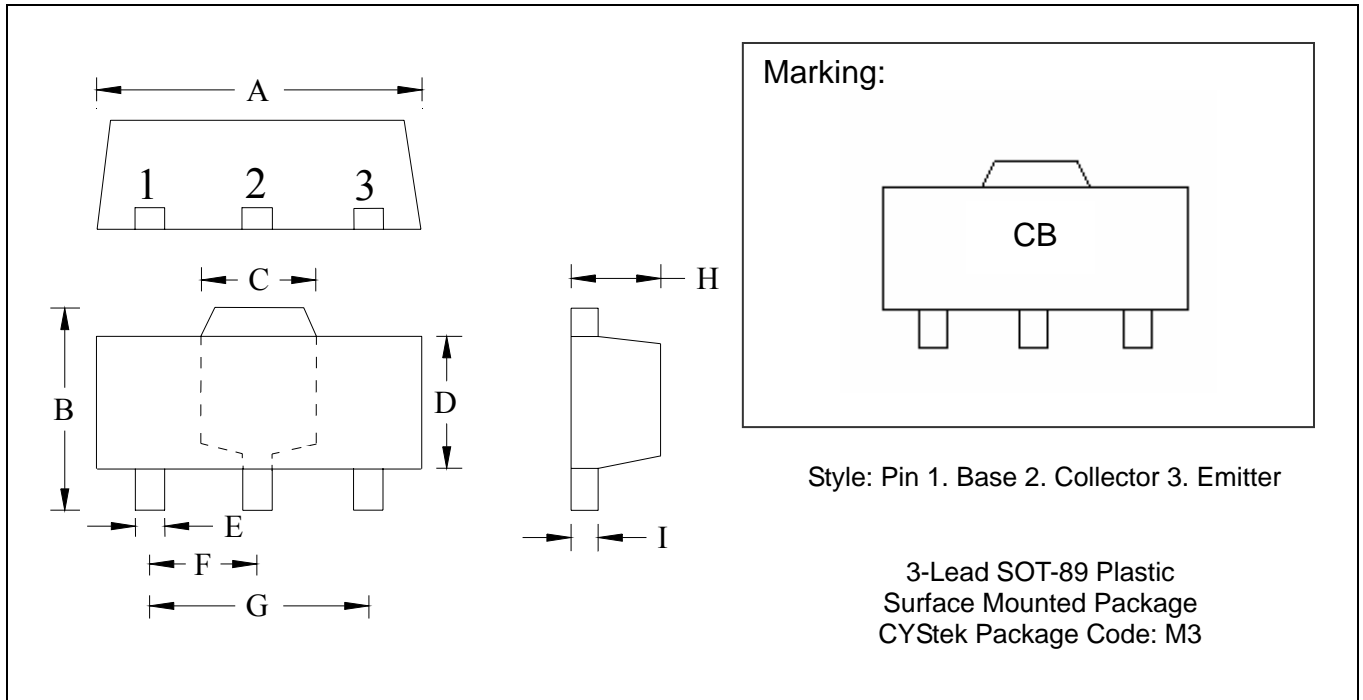

*: Typical

DIM	Inches		Millimeters		DIM	Inches		Millimeters	
	Min.	Max.	Min.	Max.		Min.	Max.	Min.	Max.
A	0.1732	0.1811	4.40	4.60	F	0.0583	0.0598	1.48	1.527
B	0.1594	0.1673	4.05	4.25	G	0.1165	0.1197	2.96	3.04
C	0.0591	0.0663	1.50	1.70	H	0.0551	0.0630	1.40	1.60
D	0.0945	0.1024	2.40	2.60	I	0.0138	0.0161	0.35	0.41
E	0.01417	0.0201	0.36	0.51					

Notes: 1.Controlling dimension: millimeters.
 2.Maximum lead thickness includes lead finish thickness, and minimum lead thickness is the minimum thickness of base material.
 3.If there is any question with packing specification or packing method, please contact your local CYStek sales office.

Material:

- Lead: KFC ; pure tin plated
- Mold Compound: Epoxy resin family, flammability solid burning class: UL94V-0

Important Notice:

- All rights are reserved. Reproduction in whole or in part is prohibited without the prior written approval of CYStek.
- CYStek reserves the right to make changes to its products without notice.
- CYStek **semiconductor products are not warranted to be suitable for use in Life-Support Applications, or systems.**
- CYStek assumes no liability for any consequence of customer product design, infringement of patents, or application assistance.