

### Features

- **Single 12V Power Supply Required**
- **Fast Transient Response**  
- 0~90% Duty Ratio
- **0.8V Reference with 1% Accuracy**
- **Shutdown Function by Controlling COMP Pin Voltage**
- **Internal Soft-Start (1.7ms) Function**
- **Voltage Mode PWM Control Design**
- **Under-Voltage Protection**
- **Over-Current Protection**  
- Sense Low Side MOSFET's  $R_{DS(ON)}$
- **300kHz Fixed Switching Frequency**
- **SOP-8 Package**
- **Lead Free and Green Devices Available (RoHS Compliant)**

### Simplified Application Circuit

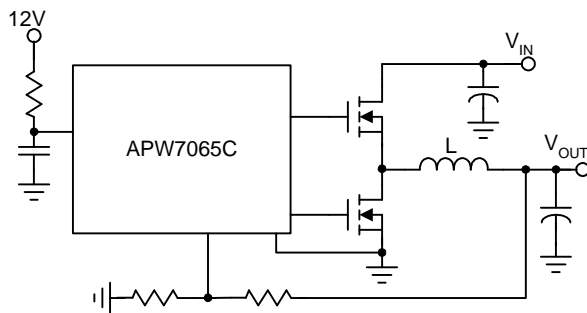

### Pin Configuration

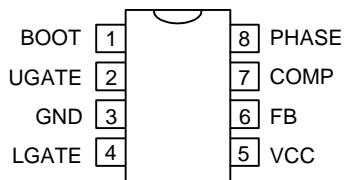

SOP-8  
(APW7065C)

### General Description

The APW7065C uses fixed 300kHz switching frequency, voltage mode, synchronous PWM controller which drives dual N-channel MOSFETs. The device integrates the control, monitoring and protection functions into a single package, provides one controlled power output with under-voltage and over-current protections.

The APW7065C provides excellent regulation for output load variation. The internal 0.8V temperature-compensated reference voltage is designed to meet the requirement of low output voltage applications. An built-in digital soft-start with fixed soft-start interval prevents the output voltage from overshoot as well as limiting the input current.

The APW7065C with excellent protection functions: POR, OCP and UVP. The Power-On-Reset (POR) circuit can monitor VCC supply voltage exceeds its threshold voltage while the controller is running, and a built-in digital soft-start provides output with controlled voltage rise. The Over-Current Protection (OCP) monitors the output current by using the voltage drop across the lower MOSFET's  $R_{DS(ON)}$ , comparing with internal  $V_{OCP}$  (0.29V), when the output current reaches the trip point, the IC shuts off the converter and initiates a new soft-start process. After two over-current events are counted, the device turns off both high-side and low-side MOSFETs and the converter's output is latched to be floating. It requires a POR of VCC to restart. The Under-Voltage Protection (UVP) monitors the voltage of FB pin for short-circuit protection, when the  $V_{FB}$  is less than 50% of  $V_{REF}$  (0.4V), the controller will shutdown the IC directly.

### Applications

- **Graphics Card**
- **Mother Board**

ANPEC reserves the right to make changes to improve reliability or manufacturability without notice, and advise customers to obtain the latest version of relevant information to verify before placing orders.

## Ordering and Marking Information

<p>APW7065C □□□-□□□</p> <div style="margin-left: 40px;"> <p>└─ Assembly Material</p> <p>└─ Handling Code</p> <p>└─ Temp. Range</p> <p>└─ Package Code</p> </div>	<p>Package Code K : SOP-8</p> <p>Operating Ambient Temp. Range E : -20 to 70°C</p> <p>Handling Code TR : Tape &amp; Reel</p> <p>Assembly Material L : Lead Free Device    G : Halogen and Lead Free Device</p>
<p>APW7065C K :</p> <div style="border: 1px solid black; padding: 2px; display: inline-block;"> <p>APW7065 XXXXX C</p> </div>	<p>XXXXX - Date Code</p>

Note: ANPEC lead-free products contain molding compounds/die attach materials and 100% matte tin plate termination finish; which are fully compliant with RoHS. ANPEC lead-free products meet or exceed the lead-free requirements of IPC/JEDEC J-STD-020C for MSL classification at lead-free peak reflow temperature. ANPEC defines "Green" to mean lead-free (RoHS compliant) and halogen free (Br or Cl does not exceed 900ppm by weight in homogeneous material and total of Br and Cl does not exceed 1500ppm by weight).

## Absolute Maximum Ratings (Note 1)

Symbol	Parameter	Rating	Unit
$V_{CC}$	VCC to GND	-0.3 ~ 16	V
$V_{BOOT}$	BOOT to PHASE	-0.3 ~ 16	V
$V_{UGATE}$	UGATE to PHASE <400ns pulse width >400ns pulse width	-5 ~ $V_{BOOT}+5$ -0.3 ~ $V_{BOOT}+0.3$	V
$V_{LGATE}$	LGATE to GND <400ns pulse width >400ns pulse width	-5 ~ $V_{CC}+5$ -0.3 ~ $V_{CC}+0.3$	V
$V_{PHASE}$	PHASE to GND <200ns pulse width >200ns pulse width	-10 ~ 30 -0.3 ~ 16	V
$V_{COMP}, V_{FB}$	COMP, FB to GND	-0.3 ~ 7	V
$T_J$	Junction Temperature Range	-20 ~ 150	°C
$T_{STG}$	Storage Temperature Range	-65 ~ 150	°C
$T_{SDR}$	Maximum Lead Soldering Temperature, 10 Seconds	260	°C

Note 1: Absolute Maximum Ratings are those values beyond which the life of a device may be impaired. Exposure to absolute maximum rating conditions for extended periods may affect device reliability.

## Thermal Characteristics

Symbol	Parameter	Value	Unit
$\theta_{JA}$	Junction-to-Ambient Thermal Resistance in Free Air SOP-8	160	°C/W

## Recommended Operating Conditions

Symbol	Parameter	Range	Unit
V <sub>CC</sub>	VCC Supply Voltage	10.8 ~ 13.2	V
V <sub>OUT</sub>	Converter Output Voltage	0.8 ~ 5	V
V <sub>IN</sub>	Converter Input Voltage	2.9 ~ 13.2	V
I <sub>OUT</sub>	Converter Output Current	0 ~ 25	A
T <sub>A</sub>	Ambient Temperature Range	-20 ~ 70	°C
T <sub>J</sub>	Junction Temperature Range	-20 ~ 125	°C

## Electrical Characteristics

Unless otherwise specified, these specifications apply over V<sub>CC</sub>=12V, and T<sub>A</sub> = -20~70°C. Typical values are at T<sub>A</sub>=25°C.

Symbol	Parameter	Test Conditions	APW7065C			Unit
			Min	Typ	Max	
<b>SUPPLY CURRENT</b>						
I <sub>VCC</sub>	VCC Nominal Supply Current	UGATE and LGATE Open	-	5	10	mA
	VCC Shutdown Supply Current	UGATE, LGATE = GND	-	1	2	mA
<b>POWER-ON-RESET</b>						
	Rising VCC Threshold		9	9.5	10	V
	Falling VCC Threshold		7.5	8	8.5	V
	COMP Shutdown Threshold		-	1.2	-	V
	COMP Shutdown Hysteresis		-	0.1	-	V
<b>OSCILLATOR</b>						
F <sub>OSC</sub>	Free Running Frequency		270	300	345	kHz
ΔV <sub>OSC</sub>	Ramp Amplitude		-	1.6	-	V <sub>P-P</sub>
<b>REFERENCE VOLTAGE</b>						
V <sub>REF</sub>	Reference Voltage	Measured at FB Pin	-	0.8	-	V
	Accuracy	T <sub>A</sub> = -20~70°C	-1.0	-	+1.0	%
<b>ERROR AMPLIFIER</b>						
Gain	Open Loop Gain	R <sub>L</sub> =10K, C <sub>L</sub> =10pF <sup>(Note2)</sup>	-	88	-	dB
GBWP	Open Loop Bandwidth	R <sub>L</sub> =10K, C <sub>L</sub> =10pF <sup>(Note2)</sup>	-	15	-	MHz
SR	Slew Rate	R <sub>L</sub> =10K, C <sub>L</sub> =10pF <sup>(Note2)</sup>	-	6	-	V/μs
	FB Input Current	V <sub>FB</sub> = 0.8V <sup>(Note2)</sup>	-	0.1	1	μA
V <sub>COMP</sub>	COMP High Voltage		-	5.5	-	V
V <sub>COMP</sub>	COMP Low Voltage		-	0	-	V
I <sub>COMP</sub>	COMP Source Current	V <sub>COMP</sub> =2V	-	5	-	mA
I <sub>COMP</sub>	COMP Sink Current	V <sub>COMP</sub> =2V	-	5	-	mA

## Electrical Characteristics (Cont.)

Unless otherwise specified, these specifications apply over  $V_{CC} = 12V$ , and  $T_A = -20 \sim 70^\circ C$ . Typical values are at  $T_A = 25^\circ C$ .

Symbol	Parameter	Test Conditions	APW7065C			Unit
			Min	Typ	Max	
<b>GATE DRIVERS</b>						
$I_{UGATE}$	Upper Gate Source Current	$V_{BOOT} = 12V, V_{UGATE} - V_{PHASE} = 2V$	-	2.6	-	A
$I_{UGATE}$	Upper Gate Sink Current	$V_{BOOT} = 12V, V_{UGATE} - V_{PHASE} = 2V$	-	1.05	-	A
$I_{LGATE}$	Lower Gate Source Current	$V_{CC} = 12V, V_{LGATE} = 2V$	-	4.9	-	A
$I_{LGATE}$	Lower Gate Sink Current	$V_{CC} = 12V, V_{LGATE} = 2V$	-	1.4	-	A
$R_{UGATE}$	Upper Gate Source Impedance	$V_{BOOT} = 12V, I_{UGATE} = 0.1A$	-	2	3	$\Omega$
$R_{UGATE}$	Upper Gate Sink Impedance	$V_{BOOT} = 12V, I_{UGATE} = 0.1A$	-	1.6	2.4	$\Omega$
$R_{LGATE}$	Lower Gate Source Impedance	$V_{CC} = 12V, I_{LGATE} = 0.1A$	-	1.3	1.95	$\Omega$
$R_{LGATE}$	Lower Gate Sink Impedance	$V_{CC} = 12V, I_{LGATE} = 0.1A$	-	1.25	1.88	$\Omega$
$T_D$	Dead Time		-	20	-	ns
<b>PROTECTIONS</b>						
$V_{OCP}$	Over-Current Reference Voltage	$T_A = -20 \sim 70^\circ C$	0.27	0.29	0.31	V
$V_{UVP}$	Under-Voltage Threshold Trip Point	Percent of $V_{REF}$	45	50	55	%
<b>SOFT-START</b>						
$T_{SS}$	Soft-Start Interval		1	1.7	2.6	ms
$T_{delay}$	Delay Time <sup>(Note 2)</sup>		1.1	1.6	2.1	ms

Note 2: Guaranteed by design.

## Typical Operating Characteristics

Switching Frequency vs. Junction Temperature

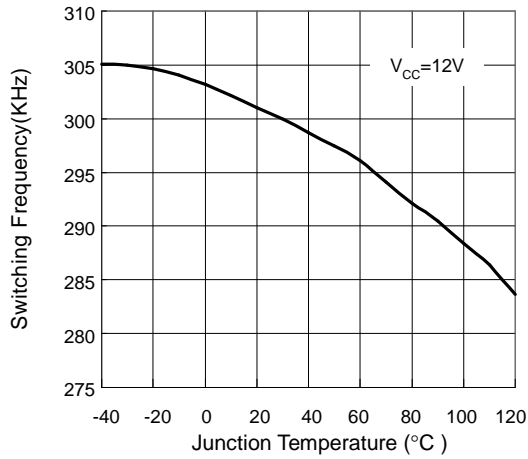

Reference Voltage vs. Junction Temperature

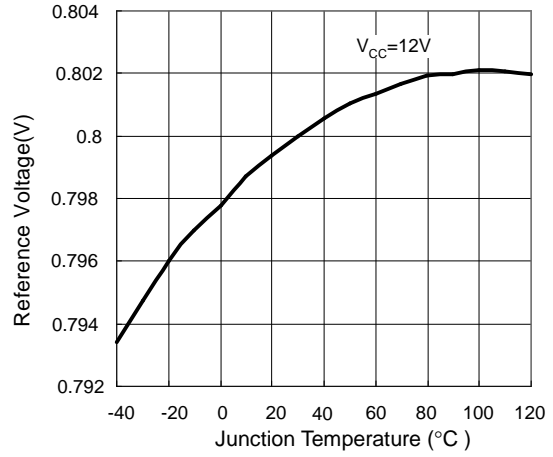

## Operating Waveforms

Power On

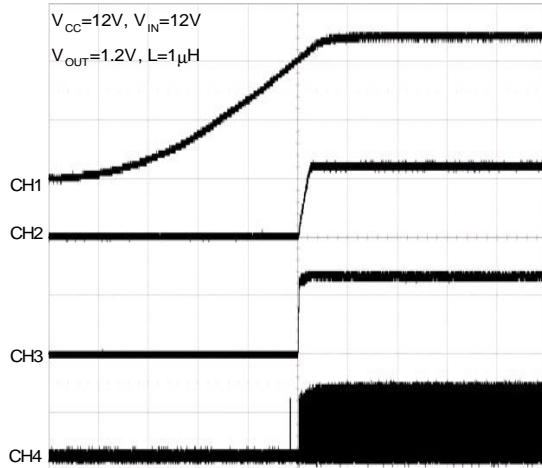

CH1:  $V_{CC}$  (5V/div)  
 CH2:  $V_{OUT}$  (1V/div)  
 CH3:  $V_{COMP}$  (1V/div)  
 CH4:  $V_{UGATE}$  (20V/div)  
 Time: 10ms/div

Power Off

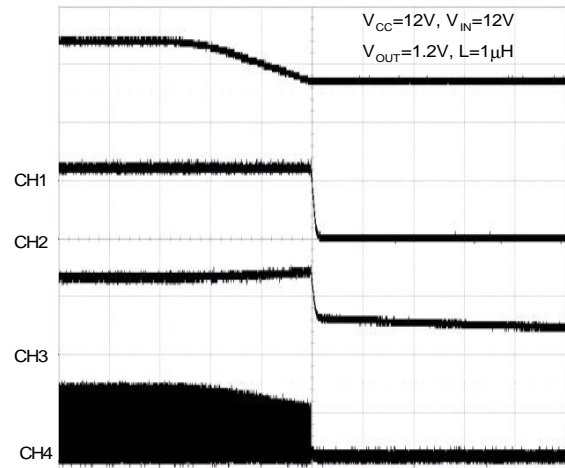

CH1:  $V_{CC}$  (5V/div)  
 CH2:  $V_{OUT}$  (1V/div)  
 CH3:  $V_{COMP}$  (1V/div)  
 CH4:  $V_{UGATE}$  (20V/div)  
 Time: 10ms/div

## Operating Waveforms

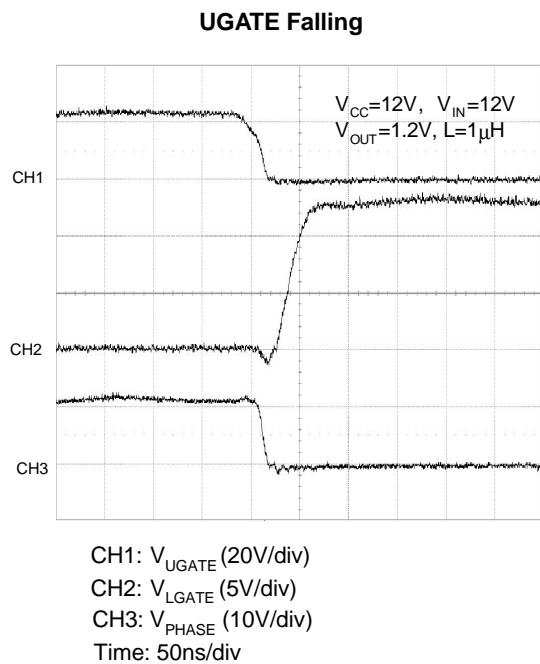
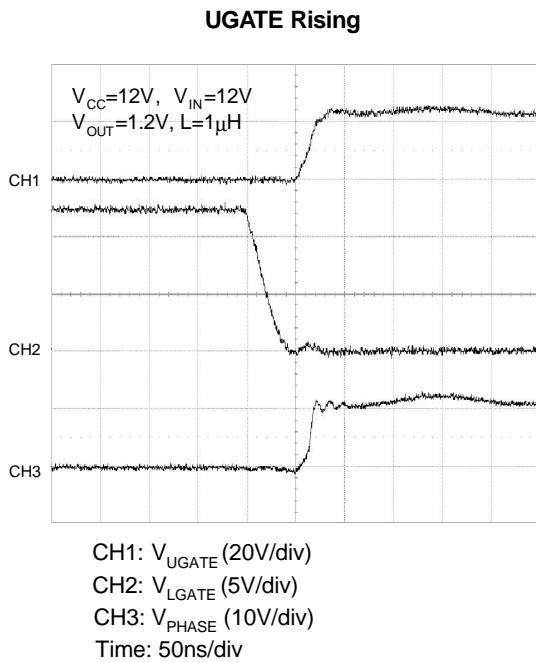
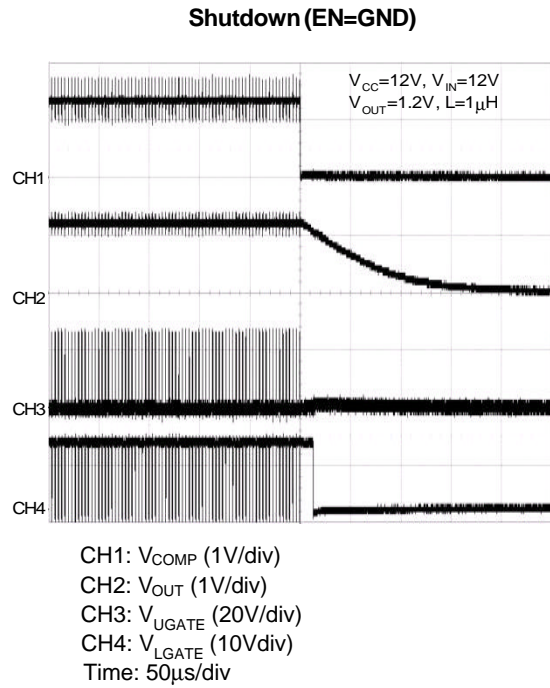
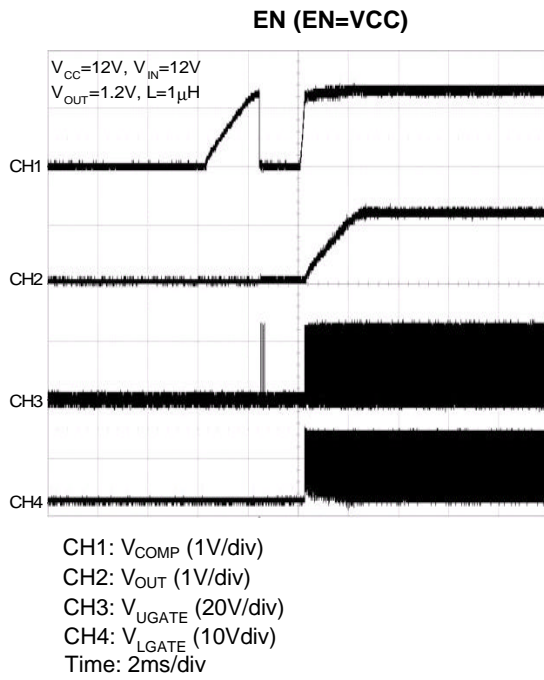

Operating Waveforms (Cont.)

Load Transient Response

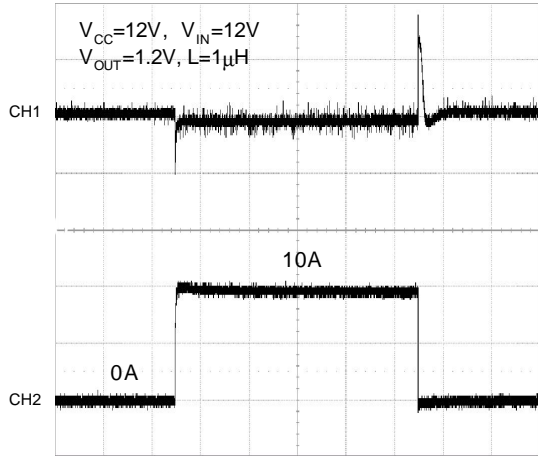

CH1:  $V_{OUT}$  (500mV/div)  
 CH2:  $I_{OUT}$  (5A/div)  
 Time: 200µs/div

Under Voltage Protection

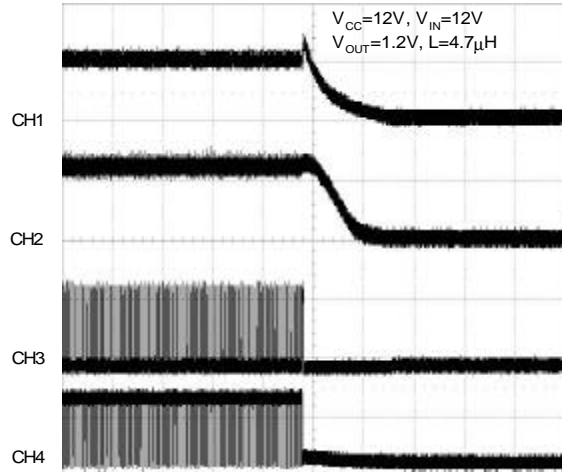

CH1:  $I_L$  (10A/div)  
 CH2:  $V_{OUT}$  (1V/div)  
 CH3:  $V_{UGATE}$  (20V/div)  
 CH3:  $V_{LGATE}$  (10V/div)  
 Time: 100µs/div

Over Current Protection

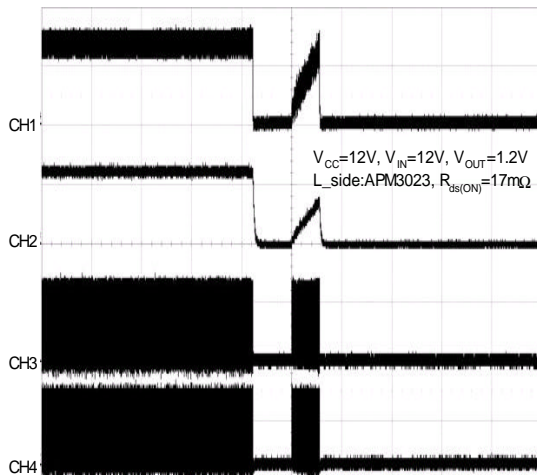

CH1:  $I_L$  (10A/div)  
 CH2:  $V_{OUT}$  (1V/div)  
 CH3:  $V_{UGATE}$  (20V/div)  
 CH3:  $V_{LGATE}$  (10V/div)  
 Time: 2ms/div

Short Test

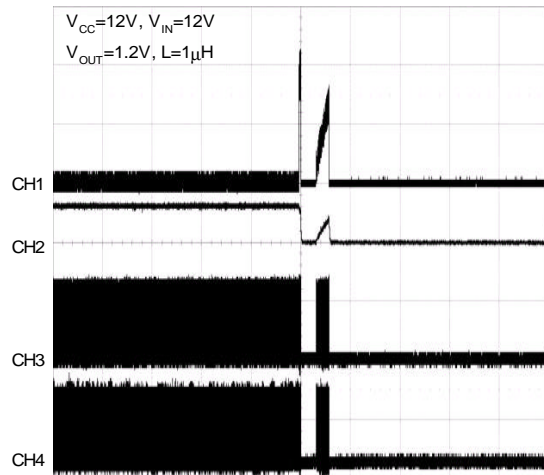

CH1:  $I_L$  (10A/div)  
 CH2:  $V_{OUT}$  (2V/div)  
 CH3:  $V_{UGATE}$  (20V/div)  
 CH3:  $V_{LGATE}$  (10V/div)  
 Time: 5ms/div

## Function Description

### BOOT (Pin 1)

A bootstrap circuit with a diode connected to VCC is used to create a voltage suitable to drive a logic-level N-channel MOSFET.

### UGATE (Pin 2)

Connect this pin to the high-side N-channel MOSFET's gate. This pin provides gate drive for the high-side MOSFET.

### GND (Pin 3)

The GND terminal provides return path for the IC's bias current and the low-side MOSFET driver's pull-low current. Connect the pin to the system ground via very low impedance layout on PCBs.

### LGATE (Pin 4)

Connect this pin to the low-side N-channel MOSFET's gate. This pin provides gate drive for the low-side MOSFET.

### VCC (Pin 5)

Connect this pin to a 12V supply voltage. This pin provides bias supply for the control circuitry and the low-side MOSFET driver. The voltage at this pin is monitored for the Power-On-Reset (POR) purpose. It is recommended that a decoupling capacitor (1 to 10 $\mu$ F) be connected to GND for noise decoupling.

### FB (Pin 6)

This pin is the inverting input of the internal error amplifier. Connect this pin to the output ( $V_{OUT}$ ) of the converter via an external resistor divider for closed-loop operation. The output voltage set by the resistor divider is determined using the following formula :

$$V_{OUT} = 0.8 \times \left( 1 + \frac{R1}{R2} \right)$$

where R1 is the resistor connected from  $V_{OUT}$  to FB , and R2 is the resistor connected from FB to GND. The FB pin is also monitored for under voltage events.

### COMP (Pin 7)

This pin is the output of PWM error amplifier. It is used to set the compensation components. In addition, if the pin is pulled below 1.2V, it will disable the device.

### PHASE (Pin 8)

This pin is the return path for the upper gate driver. Connect this pin to the upper MOSFET source. This pin is also used to monitor the voltage drop across the MOSFET for over-current protection.



Block Diagram

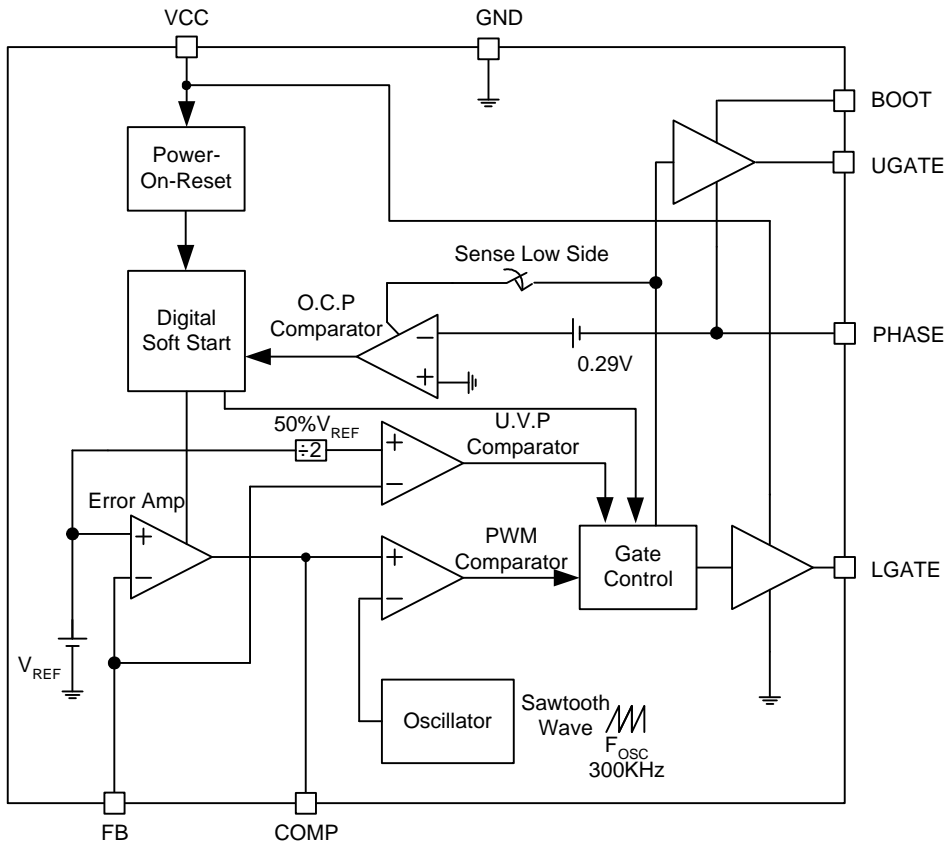

Typical Application Circuit

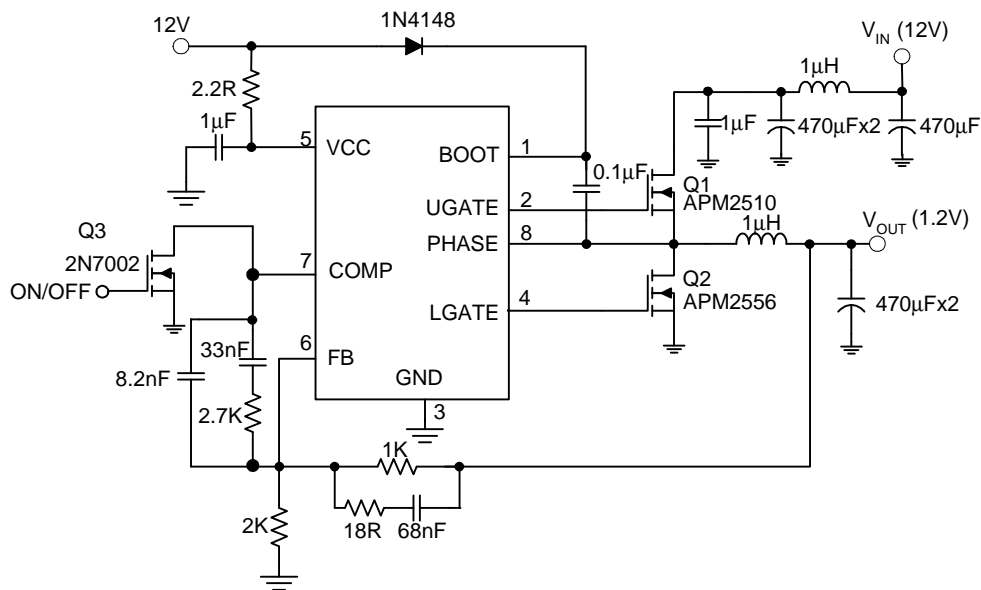

## Function Description

### Power-On-Reset (POR)

The Power-On-Reset (POR) function of APW7065C continually monitors the input supply voltage ( $V_{CC}$ ) and the COMP pin. The supply voltage ( $V_{CC}$ ) must exceed its rising POR threshold voltage. The POR function initiates soft-start operation after  $V_{CC}$  and COMP voltages exceed their POR thresholds. For operation with a single +12V power source,  $V_{IN}$  and  $V_{CC}$  are equivalent and the +12V power source must exceed the rising  $V_{CC}$  threshold. The POR function inhibits operation at disabled status ( $V_{COMP}$  is less than 1.2V). With both input supplies above their POR thresholds, the device initiates a soft-start interval.

### Soft-Start

The APW7065C has a built-in digital soft-start to control the output voltage rise and limit the current surge during the start-up. In Figure 1, when  $V_{CC}$  exceeds rising POR threshold voltage, the delay time is counted from  $t_1$  to  $t_2$  and then soft-start will be enabled. During soft-start, an internal ramp connected to the one of the positive inputs of the Gm amplifier rises up from 0V to 2V to replace the reference voltage (0.8V) until the ramp voltage reaches the reference voltage. The soft-start interval is decided by the oscillator frequency (300KHz). The formulation is given by:

$$T_{\text{soft-start}} = t_3 - t_2 = 512/F_{\text{OSC}} = 1.7\text{ms}$$

Figure 2. shows more details of the FB voltage ramp. The FB voltage soft-start ramp is formed with many small steps of voltage. The voltage of one step is about 12.5mV in FB, and the period of one step is about  $8/F_{\text{OSC}}$ . This method provides a controlled voltage rise and prevents the large peak current to charge output capacitor.

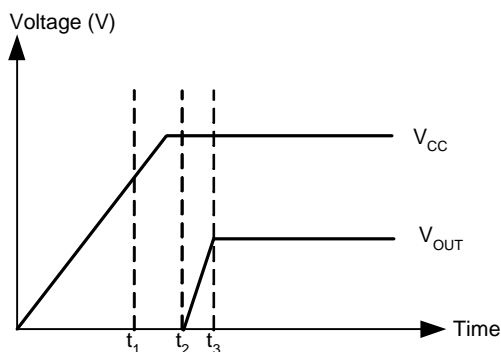

Figure 1. Soft Start Interval

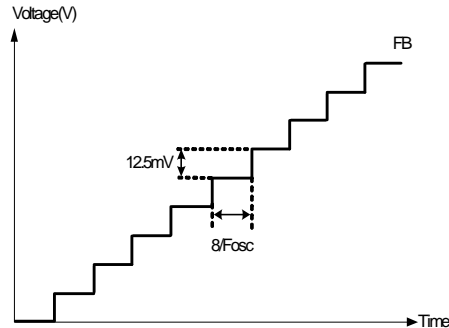

Figure 2. The Controlled Stepped FB Voltage during Soft Start

### Over-Current Protection

The over-current protection monitors the output current by using the voltage drop across the lower MOSFET's  $R_{DS(ON)}$  and this voltage drop will be compared with the internal 0.29V reference voltage. If the voltage drop across the lower MOSFET's  $R_{DS(ON)}$  is larger than 0.29V, an over-current condition is detected. The IC shuts off the converter and initiates a new soft-start process. After two over-current events are counted, the device turns off both high-side and low-side MOSFETs and the converter's output is latched to be floating. It requires a POR of  $V_{CC}$  to restart. The threshold of the over current limit is given by:

$$I_{\text{Limit}} = \frac{0.29}{R_{DS(ON)}}$$

For the over-current is never occurred in the normal operating load range; the variation of all parameters in the above equation should be determined.

- The MOSFET's  $R_{DS(ON)}$  is varied by temperature and gate to source voltage, the user should determine the maximum  $R_{DS(ON)}$  in manufacturer's datasheet.
- The minimum  $V_{ocset}$  should be used in the above equation.
- Note that the  $I_{\text{LIMIT}}$  is the current flow through the lower MOSFET;  $I_{\text{LIMIT}}$  must be greater than maximum output current and add the half of inductor ripple current.

---

## Function Description (Cont.)

### Shutdown and Enable

Pulling the COMP voltage to GND by an open drain transistor, as shown in Typical Application Circuit, shutdowns the APW7065C PWM controller. In shutdown mode, the UGATE and LGATE turn off and pull to PHASE and GND respectively.

### Under Voltage Protection

The FB pin is monitored during converter operation by the internal Under Voltage (UV) comparator. If the FB voltage drops below 50% of the reference voltage (50% of  $0.8V = 0.4V$ ), a fault signal is internally generated, and the device turns off both high-side and low-side MOSFET and the converter's output is latched to be floating.

## Application Information

### Output Voltage Selection

The output voltage can be programmed with a resistive divider. Using 1% or better resistors for the resistive divider is recommended. The FB pin is the inverter input of the error amplifier, and the reference voltage is 0.8V. The output voltage is determined by:

$$V_{OUT} = 0.8 \times \left( 1 + \frac{R_{OUT}}{R_{GND}} \right)$$

where  $R_{OUT}$  is the resistor connected from  $V_{OUT}$  to FB and  $R_{GND}$  is the resistor connected from FB to GND.

### Output Inductor Selection

The inductor value determines the inductor ripple current and affects the load transient response. Higher inductor value reduces the inductor's ripple current and induces lower output ripple voltage. The ripple current and ripple voltage can be approximated by:

$$I_{RIPPLE} = \frac{V_{IN} - V_{OUT}}{F_s \times L} \times \frac{V_{OUT}}{V_{IN}}$$

$$\Delta V_{OUT} = I_{RIPPLE} \times ESR$$

where  $F_s$  is the switching frequency of the regulator.

Although increase of the inductor value reduces the ripple current and voltage, a tradeoff will exist between the inductor's ripple current and the regulator load transient response time.

A smaller inductor will give the regulator a faster load transient response at the expense of higher ripple current. The maximum ripple current occurs at the maximum input voltage. A good starting point is to choose the ripple current to be approximately 30% of the maximum output current. Once the inductance value has been chosen, select an inductor that is capable of carrying the required peak current without going into saturation. In some types of inductors, especially core that is made of ferrite, the ripple current will increase abruptly when it saturates. This will result in a larger output ripple voltage.

### Output Capacitor Selection

Higher capacitor value and lower ESR reduce the output ripple and the load transient drop. Therefore, selecting high performance low ESR capacitors is intended for switching regulator applications. In some applications, multiple capacitors have to be parallel to achieve the desired ESR value. A small decoupling capacitor in parallel for bypassing the noise is also recommended, and the voltage rating of the output capacitors also must be considered. If tantalum capacitors are used, make sure they have been done surge test by the manufactures. If in doubt, consult the capacitors manufacturer.

### Input Capacitor Selection

The input capacitor is chosen based on the voltage rating and the RMS current rating. For reliable operation, select the capacitor voltage rating to be at least 1.3 times higher than the maximum input voltage. The maximum RMS current rating requirement is approximately  $I_{OUT}/2$ , where  $I_{OUT}$  is the load current. During power up, the input capacitors have to handle large amount of surge current. If tantalum capacitors are used, make sure they are surge tested by the manufactures. If in doubt, consult the capacitors manufacturer. For high frequency decoupling, a ceramic capacitor 1 $\mu$ F can be connected between the drain of upper MOSFET and the source of lower MOSFET.

### MOSFET Selection

The selection of the N-channel power MOSFETs are determined by the  $R_{DS(ON)}$ , which reverses transfer capacitance ( $C_{RSS}$ ) and maximizes output current requirement. There are two components of loss in the MOSFETs: conduction loss and transition loss. For the upper and lower MOSFET, the losses are approximately given by the following:

$$P_{UPPER} = I_{OUT}^2 (1 + TC) (R_{DS(ON)}) D + (0.5) (I_{OUT}) (V_{IN}) (t_{SW}) F_s$$

$$P_{LOWER} = I_{OUT}^2 (1 + TC) (R_{DS(ON)}) (1 - D)$$

Where  $I_{OUT}$  is the load current

TC is the temperature dependency of  $R_{DS(ON)}$

$F_s$  is the switching frequency

**Application Information (Cont.)**

**MOSFET Selection (Cont.)**

$t_{sw}$  is the switching interval  
 D is the duty cycle

Note that both MOSFETs have conduction loss while the upper MOSFET, including an additional transition loss. The switching interval,  $t_{sw}$ , is a function of the reverse transfer capacitance  $C_{RSS}$ . The (1+TC) term is to factor in the temperature dependency of the  $R_{DS(ON)}$  and can be extracted from the “ $R_{DS(ON)}$  vs. Temperature” curve of the power MOSFET.

**PWM Compensation**

The output LC filter of a step down converter introduces a double pole, which contributes with -40dB/decade gain slope and 180 degrees phase shift in the control loop. A compensation network among COMP, FB and  $V_{OUT}$  should be added. The compensation network is shown in Figure 6. The output LC filter consists of the output inductor and output capacitors. The transfer function of the LC filter is given by:

$$GAIN_{LC} = \frac{1 + s \times ESR \times C_{OUT}}{s^2 \times L \times C_{OUT} + s \times ESR \times C_{OUT} + 1}$$

The poles and zero of this transfer functions are:

$$F_{LC} = \frac{1}{2 \times \pi \times \sqrt{L \times C_{OUT}}}$$

$$F_{ESR} = \frac{1}{2 \times \pi \times ESR \times C_{OUT}}$$

The  $F_{LC}$  is the double poles of the LC filter, and  $F_{ESR}$  is the zero introduced by the ESR of the output capacitor.

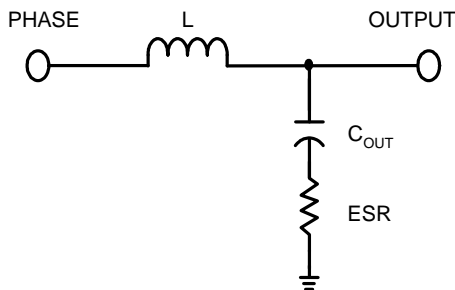

Figure 3. The Output LC Filter

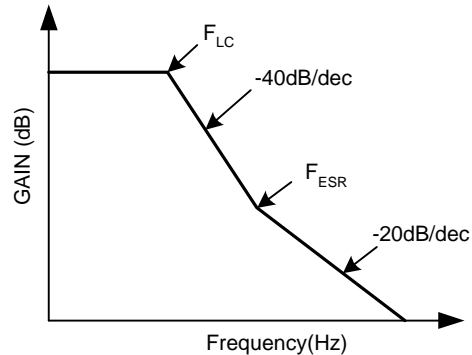

Figure 4. The LC Filter GAIN and Frequency

The PWM modulator is shown in Figure 5. The input is the output of the error amplifier and the output is the PHASE node. The transfer function of the PWM modulator is given by:

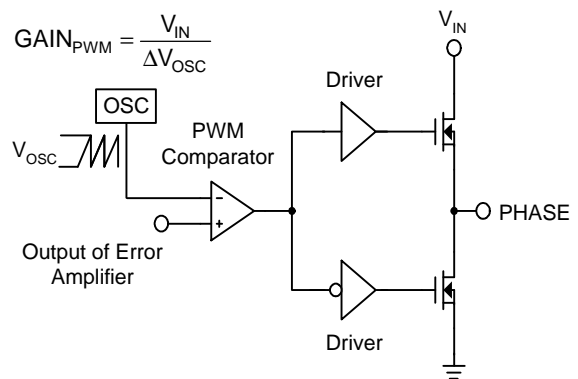

Figure 5. The PWM Modulator

The compensation network is shown in Figure 6. It provides a close loop transfer function with the highest zero crossover frequency and sufficient phase margin. The transfer function of error amplifier is given by:

$$GAIN_{AMP} = \frac{V_{COMP}}{V_{OUT}} = \frac{1}{sC1} // \left( R2 + \frac{1}{sC2} \right) / \left( R1 // \left( R3 + \frac{1}{sC3} \right) \right)$$

$$= \frac{R1+R3}{R1 \times R3 \times C1} \times \left( s + \frac{1}{R2 \times C2} \right) \times \left( s + \frac{1}{(R1+R3) \times C3} \right) / \left( s + \frac{C1+C2}{R2 \times C1 \times C2} \right) \times \left( s + \frac{1}{R3 \times C3} \right)$$

## Application Information (Cont.)

### PWM Compensation (Cont.)

The poles and zeros of the transfer function are:

$$F_{Z1} = \frac{1}{2 \times \pi \times R2 \times C2}$$

$$F_{Z2} = \frac{1}{2 \times \pi \times (R1 + R3) \times C3}$$

$$F_{P1} = \frac{1}{2 \times \pi \times R2 \times \left( \frac{C1 \times C2}{C1 + C2} \right)}$$

$$F_{P2} = \frac{1}{2 \times \pi \times R3 \times C3}$$

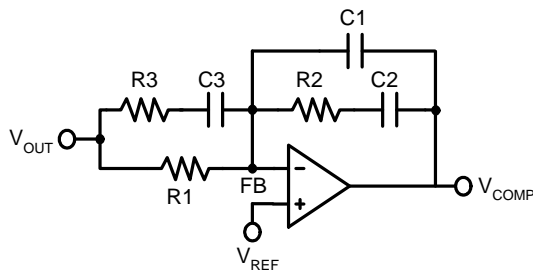

Figure 6. Compensation Network

The closed loop gain of the converter can be written as:

$$GAIN_{LC} \times GAIN_{PWM} \times GAIN_{AMP}$$

Figure 7. shows the asymptotic plot of the closed loop converter gain, and the following guidelines will help to design the compensation network. Using the below guidelines should give a compensation similar to the curve plotted. A stable closed loop has a -20dB/decade slope and a phase margin greater than 45 degree.

1. Choose a value for R1, usually between 1K and 5K.

2. Select the desired zero crossover frequency  $F_o$ :

$$(1/5 \sim 1/10) \times F_s > F_o > F_{ESR}$$

Use the following equation to calculate R2:

$$R2 = \frac{\Delta V_{OSC}}{V_{IN}} \times \frac{F_o}{F_{LC}} \times R1$$

3. Place the first zero  $F_{Z1}$  before the output LC filter double pole frequency  $F_{LC}$ .

$$F_{Z1} = 0.75 \times F_{LC}$$

Calculate the C2 by the equation:

$$C2 = \frac{1}{2 \times \pi \times R2 \times F_{LC} \times 0.75}$$

4. Set the pole at the ESR zero frequency  $F_{ESR}$ :

$$F_{P1} = F_{ESR}$$

Calculate the C1 by the equation:

$$C1 = \frac{C2}{2 \times \pi \times R2 \times C2 \times F_{ESR} - 1}$$

5. Set the second pole  $F_{P2}$  at the half of the switching frequency and also set the second zero  $F_{Z2}$  at the output LC filter double pole  $F_{LC}$ . The compensation gain should not exceed the error amplifier open loop gain, check the compensation gain at  $F_{P2}$  with the capabilities of the error amplifier.

$$F_{P2} = 0.5 \times F_s$$

$$F_{Z2} = F_{LC}$$

Combine the two equations will get the following component calculations:

$$R3 = \frac{R1}{\frac{F_s}{2 \times F_{LC}} - 1}$$

$$C3 = \frac{1}{\pi \times R3 \times F_s}$$

## Application Information (Cont.)

### PWM Compensation (Cont.)

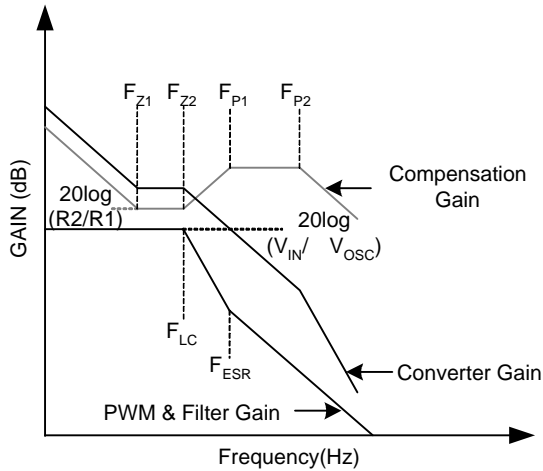

Figure 7. Converter Gain and Frequency

### Layout Consideration

In any high switching frequency converter, a correct layout is important to ensure proper operation of the regulator. With power devices switching at 300kHz, the resulting current transient will cause voltage spike across the interconnecting impedance and parasitic circuit elements. As an example, consider the turn-off transition of the PWM MOSFET. Before turn-off, the MOSFET is carrying the full load current. During turn-off, current stops flowing in the MOSFET and is free-wheeling by the lower MOSFET and parasitic diode. Any parasitic inductance of the circuit generates a large voltage spike during the switching interval. In general, using short, wide printed circuit traces should minimize interconnecting impedances and the magnitude of voltage spike. In addition, signal and power grounds are to be kept separate till combined using ground plane construction or single point grounding. Figure 8. illustrates the layout, with bold lines indicating high current paths; these traces must be short and wide. Components along the bold lines should be placed close together. Below is a checklist for your layout:

- Keep the switching nodes (UGATE, LGATE and PHASE) away from sensitive small signal nodes since these nodes are fast moving signals. Therefore,

keep traces to these nodes as short as possible.

- The traces from the gate drivers to the MOSFETs (UG, LG) should be short and wide.

- Place the source of the high-side MOSFET and the drain of the low-side MOSFET as close as possible. Minimizing the impedance with wide layout plane between the two pads reduces the voltage bounce of the node.

- Decoupling capacitor, compensation component, the resistor dividers, and boot capacitors should be close their pins. (For example, place the decoupling ceramic capacitor near the drain of the high-side MOSFET as close as possible. The bulk capacitors are also placed near the drain).

- The input capacitor should be near the drain of the upper MOSFET; the output capacitor should be near the loads. The input capacitor GND should be close to the output capacitor GND and the lower MOSFET GND.

- The drain of the MOSFETs ( $V_{IN}$  and PHASE nodes) should be a large plane for heat sinking.

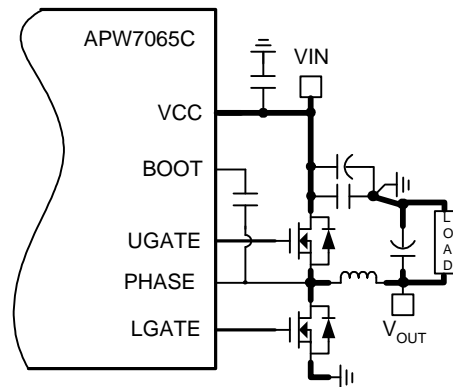
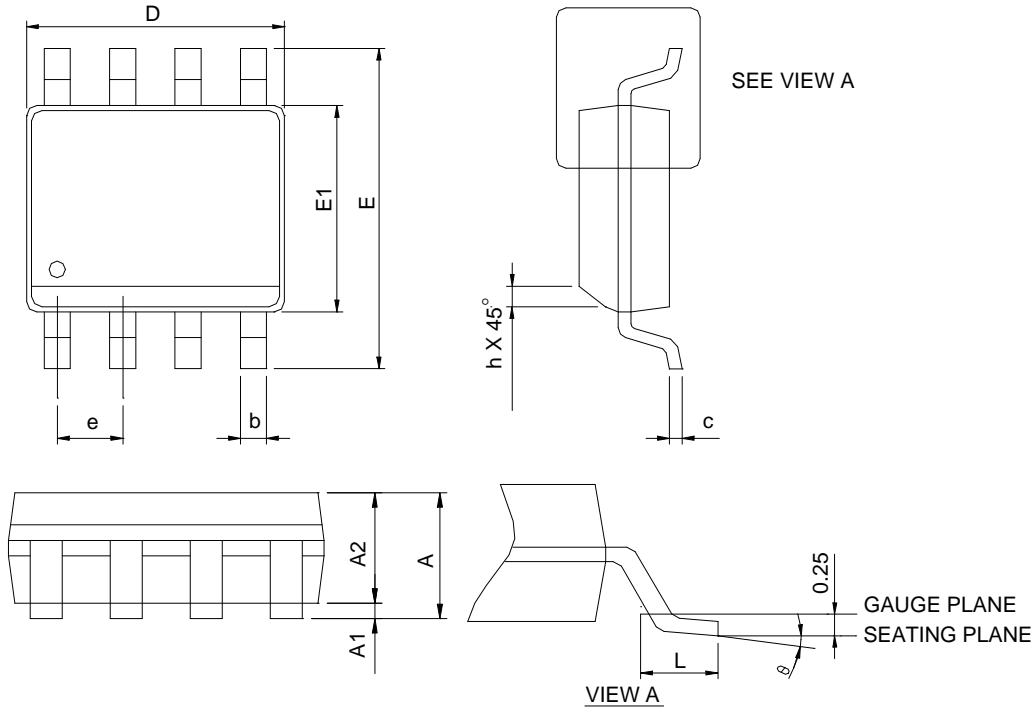

Figure 8. Layout Guidelines

Package Information

SOP-8



SYMBOL	SOP-8			
	MILLIMETERS		INCHES	
	MIN.	MAX.	MIN.	MAX.
A		1.75		0.069
A1	0.10	0.25	0.004	0.010
A2	1.25		0.049	
b	0.31	0.51	0.012	0.020
c	0.17	0.25	0.007	0.010
D	4.80	5.00	0.189	0.197
E	5.80	6.20	0.228	0.244
E1	3.80	4.00	0.150	0.157
e	1.27 BSC		0.050 BSC	
h	0.25	0.50	0.010	0.020
L	0.40	1.27	0.016	0.050
θ	0°	8°	0°	8°

- Note: 1. Follow JEDEC MS-012 AA.  
 2. Dimension "D" does not include mold flash, protrusions or gate burrs. Mold flash, protrusion or gate burrs shall not exceed 6 mil per side.  
 3. Dimension "E" does not include inter-lead flash or protrusions. Inter-lead flash and protrusions shall not exceed 10 mil per side.



Carrier Tape & Reel Dimensions

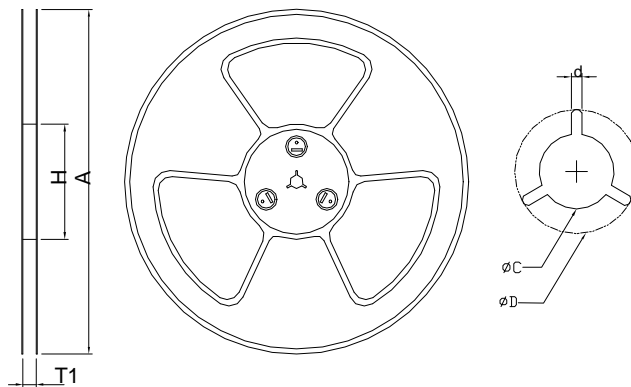
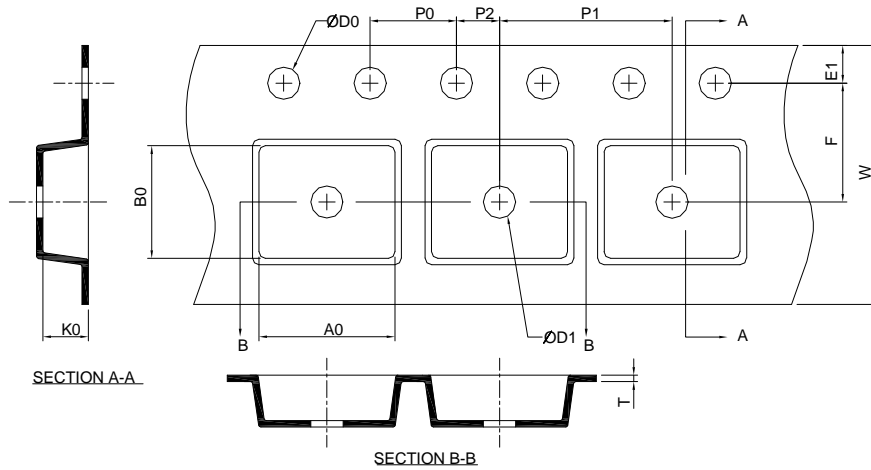

Application	A	H	T1	C	d	D	W	E1	F
SOP-8	330.0 ± 2.00	50 MIN.	12.4+2.00 -0.00	13.0+0.50 -0.20	1.5 MIN.	20.2 MIN.	12.0 ±0.30	1.75 ±0.10	5.5 ±0.05
	P0	P1	P2	D0	D1	T	A0	B0	K0
	4.0 ±0.10	8.0 ±0.10	2.0 ±0.05	1.5+0.10 -0.00	1.5 MIN.	0.6+0.00 -0.40	6.40 ±0.20	5.20 ±0.20	2.10 ±0.20

(mm)

Devices Per Unit

Package Type	Unit	Quantity
SOP-8	Tape & Reel	2500

**Reflow Condition (IR/Convection or VPR Reflow)**

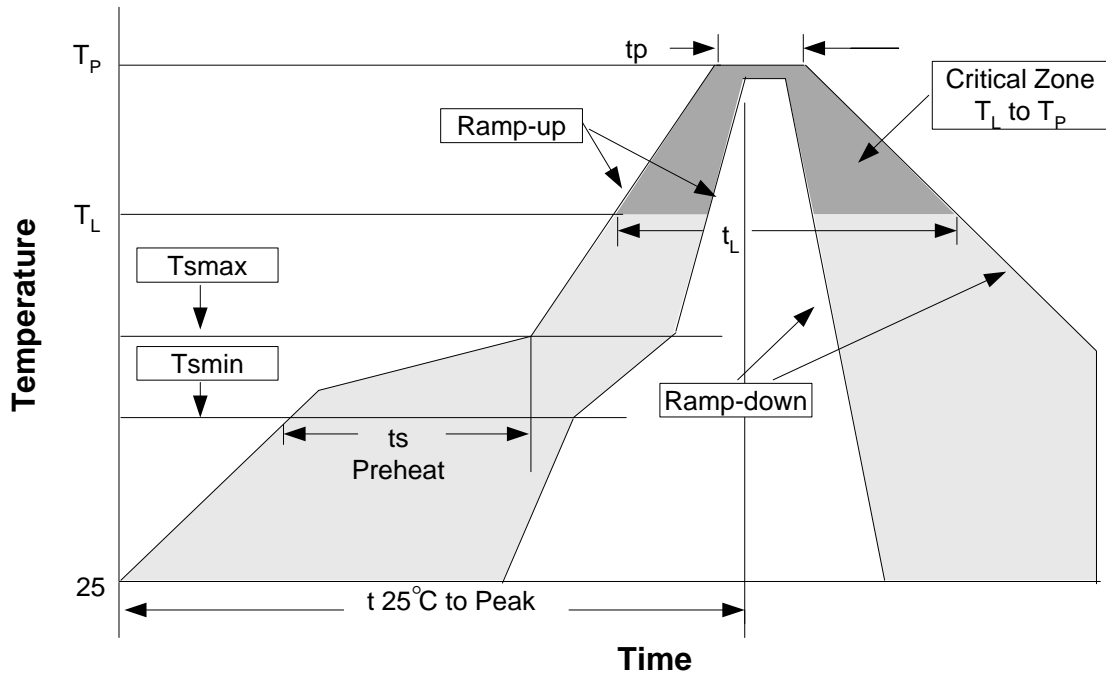

**Reliability Test Program**

Test item	Method	Description
SOLDERABILITY	MIL-STD-883D-2003	245°C, 5 sec
HOLT	MIL-STD-883D-1005.7	1000 Hrs Bias @ 125°C
PCT	JESD-22-B, A102	168 Hrs, 100%RH, 121°C
TST	MIL-STD-883D-1011.9	-65°C~150°C, 200 Cycles
ESD	MIL-STD-883D-3015.7	VHBM > 2KV, VMM > 200V
Latch-Up	JESD 78	10ms, 1 <sub>tr</sub> > 100mA

**Classification Reflow Profiles**

Profile Feature	Sn-Pb Eutectic Assembly	Pb-Free Assembly
Average ramp-up rate (T <sub>L</sub> to T <sub>P</sub> )	3°C/second max.	3°C/second max.
Preheat		
- Temperature Min (T <sub>smin</sub> )	100°C	150°C
- Temperature Max (T <sub>smax</sub> )	150°C	200°C
- Time (min to max) (t <sub>s</sub> )	60-120 seconds	60-180 seconds
Time maintained above:		
- Temperature (T <sub>L</sub> )	183°C	217°C
- Time (t <sub>L</sub> )	60-150 seconds	60-150 seconds
Peak/Classification Temperature (T <sub>p</sub> )	See table 1	See table 2
Time within 5°C of actual Peak Temperature (t <sub>p</sub> )	10-30 seconds	20-40 seconds
Ramp-down Rate	6°C/second max.	6°C/second max.
Time 25°C to Peak Temperature	6 minutes max.	8 minutes max.

Note: All temperatures refer to topside of the package. Measured on the body surface.

**Classification Reflow Profiles (Cont.)**

Table 1. SnPb Eutectic Process – Package Peak Reflow Temperatures

Package Thickness	Volume mm <sup>3</sup> <350	Volume mm <sup>3</sup> ≥350
<2.5 mm	240 +0/-5°C	225 +0/-5°C
≥2.5 mm	225 +0/-5°C	225 +0/-5°C

Table 2. Pb-free Process – Package Classification Reflow Temperatures

Package Thickness	Volume mm <sup>3</sup> <350	Volume mm <sup>3</sup> 350-2000	Volume mm <sup>3</sup> >2000
<1.6 mm	260 +0°C*	260 +0°C*	260 +0°C*
1.6 mm – 2.5 mm	260 +0°C*	250 +0°C*	245 +0°C*
≥2.5 mm	250 +0°C*	245 +0°C*	245 +0°C*

\*Tolerance: The device manufacturer/supplier **shall** assure process compatibility up to and including the stated classification temperature (this means Peak reflow temperature +0°C. For example 260°C+0°C) at the rated MSL level.

**Customer Service**

**Anpec Electronics Corp.**

Head Office :

No.6, Dusing 1st Road, SBIP,  
Hsin-Chu, Taiwan  
Tel : 886-3-5642000  
Fax : 886-3-5642050

Taipei Branch :

2F, No. 11, Lane 218, Sec 2 Jhongsing Rd.,  
Sindian City, Taipei County 23146, Taiwan  
Tel : 886-2-2910-3838  
Fax : 886-2-2917-3838