

ZMD31050 RB^{IC} series

Advanced Differential Sensor Signal Conditioner

Datasheet

PRELIMINARY

Features

- Digital compensation of sensor offset, sensitivity, temperature drift and non-linearity
- Accommodates nearly all bridge sensors by PGA and programmable ADC
- Capable with sensor signals from 1 up to 275mV/V span
- Sensor connections check and aging detection
- Selectable temperature compensation reference: bridge, thermistor, internal diode or external diode
- Output options: voltage (0...5V), current (4...20mA), PWM, I²C, SPI, ZACwire™ (one-wire-interface), alarm
- Adjustable output resolution (up to 15 bits) versus sampling rate (up to 3.9kHz)
- Selectable bridge excitation: ratiometric voltage, constant voltage or constant current
- Input channel for separate temperature sensor
- Operation temperature -40...+125°C (-50...+150°C derated)
- Supply voltage +2.7V...+5.5V
- Available in SSOP16 or as die

Benefits

- No external trimming components required
- PC-controlled configuration and calibration via digital bus interface - simple, low cost
- High accuracy ($\pm 0.1\%$ FSO @ -25...85°C; $\pm 0.25\%$ FSO @ -40...125°C)

Application Circuit (Examples)

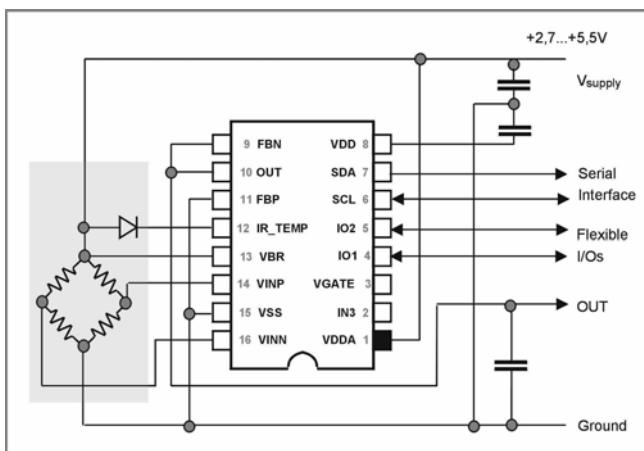

Fig. 1: Ratiometric measurement with voltage output, temperature compensation via external diode

Brief Description

The ZMD31050 is a CMOS integrated circuit that belongs to ZMD's RB^{IC} series. It performs highly-accurate amplification/scaling and sensor-specific correction of bridge sensor signals.

Digital compensation of sensor offset, sensitivity, temperature drift and non-linearity is accomplished via a 16-bit RISC micro-controller running a correction algorithm with calibration coefficients stored in non-volatile EEPROM.

The ZMD31050 accommodates virtually any bridge sensor (e.g. piezo-resistive, ceramic-thickfilm or steel membrane based). In addition, the IC can interface a separate temperature sensor.

The bi-directional digital interfaces (I²C, SPI, ZACwire™) can be used for a simple PC-controlled calibration, in order to program a set of calibration coefficients into an on-chip EEPROM. Thus a specific sensor and a ZMD31050 are mated digitally: fast, precise and without the cost overhead associated with laser trimming, or mechanical potentiometer methods.

- Application kit available (SSOP16 samples, calibration PCB, calibration software, technical documentation)
- Support for industrial mass calibration available
- Quick circuit customization possible for large production volumes

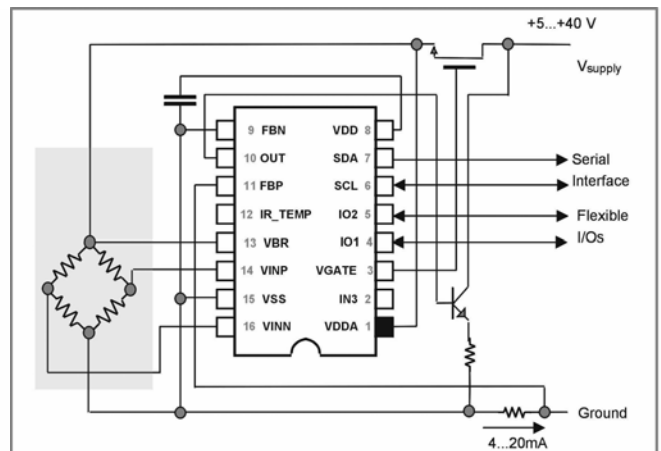

Fig. 2: Two wire 4...20mA (5...40V) configuration. Temperature compensation via internal diode

ZMD31050 RB^{IC} series

Advanced Differential Sensor Signal Conditioner

Datasheet

PRELIMINARY

Contents

| | | |
|------------|--|-----------|
| 1. | CIRCUIT DESCRIPTION | 3 |
| 1.1 | SIGNAL FLOW | 3 |
| 1.2 | APPLICATION MODES | 4 |
| 1.3 | ANALOG FRONT END (AFE) | 5 |
| 1.3.1. | <i>Programmable Gain Amplifier</i> | 5 |
| 1.3.2. | <i>Measurement Cycle Realized by Multiplexer</i> | 5 |
| 1.3.3. | <i>Analog Offset Compensation</i> | 6 |
| 1.3.4. | <i>Analog-to-Digital Converter</i> | 6 |
| 1.4 | SYSTEM CONTROL | 8 |
| 1.5 | OUTPUT STAGE | 9 |
| 1.5.1. | <i>Serial Digital Interface</i> | 10 |
| 1.5.2. | <i>ZACwire™ Single Wire Digital Interface</i> | 10 |
| 1.5.3. | <i>Analog Output</i> | 12 |
| 1.5.4. | <i>Comparator Module (ALARM Output)</i> | 13 |
| 1.6 | VOLTAGE REGULATOR | 13 |
| 1.7 | ERROR DETECTION | 14 |
| 2. | APPLICATION CIRCUIT EXAMPLES | 15 |
| 3. | ESD/LATCH-UP-PROTECTION | 15 |
| 4. | PIN CONFIGURATION AND PACKAGE | 16 |
| 5. | IC CHARACTERISTICS | 17 |
| 5.1 | ABSOLUTE MAXIMUM RATINGS | 17 |
| 5.2 | OPERATING CONDITIONS (VOLTAGES RELATED TO VSS) | 17 |
| 5.3 | BUILD IN CHARACTERISTICS | 18 |
| 5.3.8 | <i>Cycle Rate versus A/D-Resolution</i> | 19 |
| 5.3.9 | <i>PWM Frequency</i> | 19 |
| 5.4 | ELECTRICAL PARAMETERS (VOLTAGES RELATED TO VSS) | 20 |
| 5.5 | INTERFACE CHARACTERISTICS | 21 |
| 6. | TEST | 22 |
| 7. | RELIABILITY | 22 |
| 8. | CUSTOMIZATION | 22 |
| 9. | RELATED DOCUMENTS | 22 |
| 10. | ORDERING INFORMATION | 23 |

ZMD31050 RB^{IC} series

Advanced Differential Sensor Signal Conditioner

Datasheet

PRELIMINARY

1. Circuit Description

1.1 Signal Flow

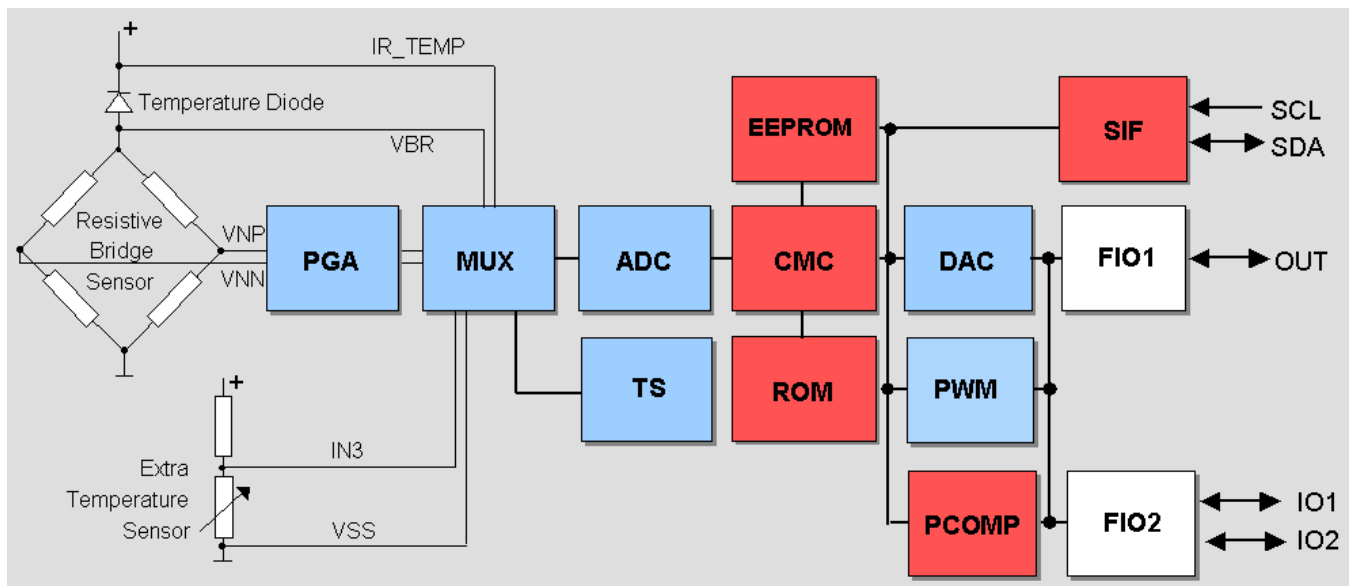

Fig.3: Block diagram of ZMD31050

| | |
|--------|---|
| PGA | programmable gain amplifier |
| MUX | multiplexer |
| ADC | analog-to-digital converter |
| CMC | calibration microcontroller |
| DAC | digital-to-analog converter |
| FIO1 | flexible I/O 1: analog out (voltage/current), PWM2, ZACwire™ (one-wire-interface) |
| FIO2 | flexible I/O 2: PWM1, SPI data out, SPI slave select, Alarm1, Alarm2 |
| SIF | serial interface: I2C data I/O, SPI data in, clock |
| PCOMP | programmable comparator |
| EEPROM | for calibration parameters and configuration |
| TS | on-chip temperature sensor (pn-junction) |
| ROM | for correction formula and -algorithm |
| PWM | PWM module |

The ZMD31050's signal path is partly analog (blue) and partly digital (red).

The differential signal from the bridge sensor is pre-amplified by the programmable gain amplifier (PGA). The Multiplexer (MUX) transmits the signals from bridge sensor, external diode or separate temperature sensor to the ADC in a certain sequence (instead of the temp. diode the internal pn-junction (TS) can be used optionally). Afterwards the ADC converts these signals into digital values. The digital signal correction takes place in the calibration micro-controller (CMC). It is based on a special correction formula located in the ROM and on sensor-specific coefficients (stored into the EEPROM during calibration).

ZMD31050 RB^{IC} series

Advanced Differential Sensor Signal Conditioner

Datasheet

PRELIMINARY

Dependent on the programmed output configuration the corrected sensor signal is output as analog value, as PWM signal or in digital format (SPI, I²C, ZACwire™). The output signal is provided at 2 flexible I/O modules (FIO) and at the serial interface (SIF). The configuration data and the correction parameters can be programmed into the EEPROM via the digital interfaces.

The modular circuit concept enables fast custom designs varying these blocks and, as a result, functionality and die size.

1.2 Application Modes

For each application a configuration set has to be established (generally prior to calibration) by programming the on-chip EEPROM regarding to the following modes:

- Sensor channel
 - Sensor mode: ratiometric voltage or current supply mode.
 - Input range: The gain of the analog front end has to be chosen with respect to the maximum sensor signal span and the zero point of the ADC has to be set with respect to the possible input voltage range
 - Additional offset compensation: The extended analog offset compensation has to be enabled if required, e.g. if the sensor offset voltage is near to or larger than the sensor span.
 - Resolution/response time: The A/D converter has to be configured for resolution and converting scheme (first or second order). These settings influence the sampling rate, signal integration time and this way the noise immunity
 - Sample order: The order and interval of multiplexed measurements (pressure, temperature, auto zero) has to be set
- Analog output
 - Choice of output method (voltage value, current loop, PWM) for output register 1.
 - Optional choice of additional output register 2: PWM module via IO1 or alarm out module via IO1/2.
- Digital communication: The preferred protocol and its parameter have to be set.
- Temperature
 - The temperature measure channel for the temperature correction has to be chosen.
 - Optional: the temperature measure channel as the second output has to be chosen.
- Supply voltage : For non-ratiometric output the voltage regulation has to be configured.

Note: *Not all possible combinations of settings are allowed (see section 1.5).*

The calibration procedure must include

- the set of coefficients of calibration calculation
- and depending on configuration,
- the adjustment of the extended offset compensation,
 - the zero compensation of temperature measurement,
 - the adjustment of the bridge current
- and if necessary
- the set of thresholds and delays for the alarms,
 - the reference voltage.

ZMD31050 RB^{IC} series**Advanced Differential Sensor Signal Conditioner**

Datasheet

PRELIMINARY

1.3 Analog Front End (AFE)

The analog front end consists of the programmable gain amplifier (PGA), the multiplexer (MUX) and the analog-to-digital converter (ADC).

1.3.1. Programmable Gain Amplifier

The following table shows the adjustable gains and the processable sensor signal spans.

| No. | PGA Gain | Max. span in mV/V |
|-----|----------|-------------------|
| 1 | 420 | 2 |
| 2 | 300 | 2.8 |
| 3 | 210 | 4 |
| 4 | 150 | 5.6 |
| 5 | 105 | 8 |
| 6 | 75 | 11.2 |
| 7 | 52.5 | 16 |
| 8 | 37.5 | 22.4 |
| 9 | 21.75 | 32 |
| 10 | 14 | 45 |
| 11 | 10 | 64 |
| 12 | 7 | 90 |
| 13 | 3 | 275 |

Table 1: Adjustable gains and processable sensor signal spans

1.3.2. Measurement Cycle Realized by Multiplexer

The Multiplexer selects, depending on EEPROM settings, the following inputs in a certain sequence.

- Pre-amplified bridge sensor signal
- Bridge temperature signal measured by external diode
- Bridge temperature signal measured by internal pn-junction
- Bridge temperature signal measured by bridge resistors
- Separate temperature signal measured by external thermistor
- Internal offset of the input channel measured by input short circuiting

ZMD31050 RB^{IC} series

Advanced Differential Sensor Signal Conditioner

Datasheet

PRELIMINARY

The complete measurement cycle is controlled by the CMC. The cycle diagram at the right shows its principle structure.

The EEPROM adjustable parameters are:

- Pressure measurement count, $n = \langle 1, 2, 4, 8, 16, 32, 64, 128 \rangle$
- Enable temperature measurement 2, $e2 = \langle 0, 1 \rangle$

After Power ON the start routine is called. It contains the pressure and auto zero measurement. When enabled it measures the temperature and its auto zeros.

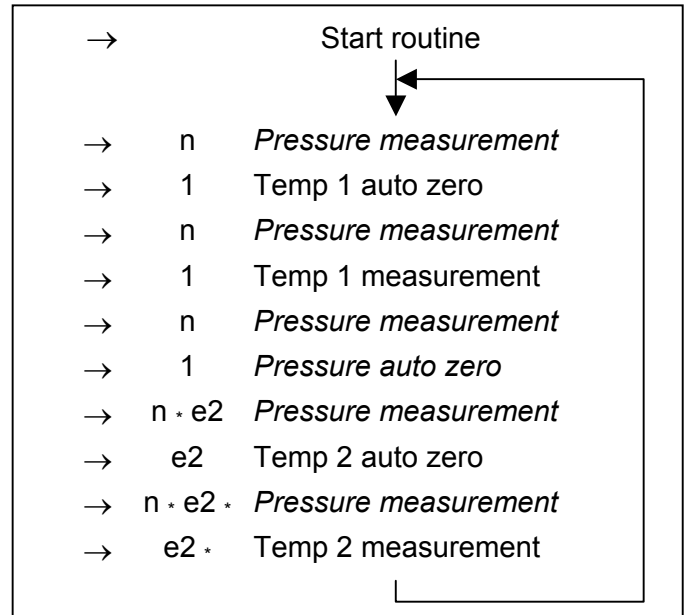

Fig. 4: Measurement cycle ZMD31050

1.3.3. Analog Offset Compensation

The bridge sensor offset is cancelled by the analog offset compensation in the AFE (coarse offset removal) and by the digital correction in the CMC (offset fine tuning). The analog offset compensation in the AFE can be adjusted by 6 EEPROM bits. It allows a zero point shift up to 300% of the processable signal span. The zero point shift of the temperature measurements can also be adjusted by 6 EEPROM bits.

1.3.4. Analog-to-Digital Converter

The ADC is a charge balancing converter in full differential switched capacitor technique. It can be used as first or second order converter:

In the **first order** mode it is inherently monotone and insensitive against short and long term instability of the clock frequency. The conversion time depends on the desired resolution and can be roughly calculated by:

$$t_c = 2^R \mu s$$

The available resolutions are $R = \langle 9, 10, 11, 12, 13, 14, 15 \rangle$.

ZMD31050 RB^{IC} series

Advanced Differential Sensor Signal Conditioner

Datasheet

PRELIMINARY

The result of the AD conversion is a relative counter result corresponding to the following equation:

$$VIN / VREF = ZOUT/N - ZS$$

| | |
|-------|---|
| ZOUT: | number of counts (result of the conversion) |
| N: | total number of counts (=2 ^R) |
| VIN: | differential input voltage of ADC |
| VREF: | differential reference voltage |
| ZS: | zero point shift (ZS=1/16, 1/8, 1/4, 1/2, controlled by the EEPROM content) |

With the ZS value a sensor input signal can be shifted in the optimal input range of the ADC.

In the **second order** mode two conversions are stacked with the advantage of much shorter conversion time and the drawback of a lower noise immunity caused by the shorter signal integration period. The conversion time at this mode is roughly calculated by:

$$t_c = 2^{(R+3)/2} \mu s$$

The available resolutions are R=<10,11,12,13,14,15>. The result of the AD conversion is a relative counter result corresponding to the following equations:

$$VIN / VREF = ZOUT/N - ZS$$

$$ZOUT = Z1 * (N2/2) + Z2$$

$$N = N1 * N2$$

| | |
|-------|--|
| Z1: | number of counts (result of the 1 st conversion) |
| Z2: | number of counts (result of the 2 nd conversion) |
| N1: | total number of counts 1 st conversion (=2 ^{(R+1)/2}) |
| N2: | total number of counts 2 nd conversion (=2 ^{(R+1)/2}) |
| VIN: | differential input voltage of ADC |
| VREF: | differential reference voltage |
| ZS: | zero point shift (RS=1/16, 1/8, 1/4, 1/2, controlled by the CMC) |

Note: The AD conversion time is only a part of a whole sample cycle. Thus the sample rate is lower than the AD conversion rate.

ZMD31050 RB^{IC} series

Advanced Differential Sensor Signal Conditioner

Datasheet

PRELIMINARY

| Order | ADC | Max. Output Resolution | | | Sample Rate |
|-------|-------------|------------------------|--------|-----|-------------|
| | Resolution* | Digital | Analog | PWM | |
| | Bit | Bit | Bit | Bit | Hz |
| 1 | 9 | 9 | 9 | 9 | 1302 |
| | 10 | 10 | 10 | 10 | 781 |
| | 11 | 11 | 11 | 11 | 434 |
| | 12 | 12 | 11 | 12 | 230 |
| | 13 | 13 | 11 | 12 | 115 |
| | 14 | 14 | 11 | 12 | 59 |
| | 15 | 15 | 11 | 12 | 30 |
| 2 | 10 | 10 | 10 | 10 | 3906 |
| | 11 | 11 | 11 | 11 | 3906 |
| | 12 | 12 | 11 | 12 | 3906 |
| | 13 | 13 | 11 | 12 | 1953 |
| | 14 | 14 | 11 | 12 | 1953 |
| | 15 | 15 | 11 | 12 | 977 |

Table 2: Output resolution versus sample rate

*ADC Resolution should be 1 or 2 Bits higher then applied Output Resolution

1.4 System Control

The system control has the following features:

- Control of the I/O relations and of the measurement cycle regarding to the EEPROM-stored configuration data
- 16 bit correction calculation for each measurement signal using the EEPROM stored calibration coefficients and ROM-based algorithms
- Started by internal POC, internal clock - generator or external clock
- For safety improvement the EEPROM data are proved with a signature within initialization procedure, the registers of the CMC are steadily observed with a parity check. Once an error is detected, the error flag of the CMC is set and the outputs are driven to a diagnostic value

Note: *The conditioning includes up to third order sensor input correction. The available adjustment ranges depend on the specific calibration parameters, a detailed description will be issued later. To give a rough idea: Offset compensation and linear correction are only limited by the loose of resolution it will cause, the second order correction is possible up to about 30% full scale difference to straight line, third order up to about 20%. The temperature calibration includes first and second order correction and should be fairly sufficient in all relevant cases.*

ZMD31050 RB^{IC} series

Advanced Differential Sensor Signal Conditioner

Datasheet

PRELIMINARY

1.5 Output Stage

| No. | Used serial IF | | Used I/O pins | | | |
|-----|------------------|-----|---------------|-----------------|----------------|-----------|
| | I ² C | SPI | OUT | IO1 | IO2 | SDA |
| 1 | X | | | | | Data I/O |
| 2 | X | | | ALARM1 | | Data I/O |
| 3 | X | | | | ALARM2 | Data I/O |
| 4 | X | | | ALARM1 | ALARM2 | Data I/O |
| 5 | X | | | PWM1 | | Data I/O |
| 6 | X | | | PWM1 | ALARM2 | Data I/O |
| 7 | X | | Analog | | | Data I/O |
| 8 | X | | Analog | ALARM1 | | Data I/O |
| 9 | X | | Analog | | ALARM2 | Data I/O |
| 10 | X | | Analog | ALARM1 | ALARM2 | Data I/O |
| 11 | X | | Analog | PWM1 | | Data I/O |
| 12 | X | | Analog | PWM1 | ALARM2 | Data I/O |
| 13 | X | | PWM2 | | | Data I/O |
| 14 | X | | PWM2 | ALARM1 | | Data I/O |
| 15 | X | | PWM2 | | ALARM2 | Data I/O |
| 16 | X | | PWM2 | ALARM1 | ALARM2 | Data I/O |
| 17 | X | | PWM2 | PWM1 | | Data I/O |
| 18 | X | | PWM2 | PWM1 | ALARM2 | Data I/O |
| 19 | | X | | Data out | Slave select | Data in |
| 20 | | X | | Data out ALARM1 | Slave select - | Data in - |
| 21 | | X | | Data out PWM1 | Slave select - | Data in - |
| 22 | | X | Analog | Data out | Slave select | Data in |
| 23 | | X | Analog | Data out ALARM1 | Slave select - | Data in - |
| 24 | | X | Analog | Data out PWM1 | Slave select - | Data in - |
| 25 | | X | PWM2 | Data out | Slave select | Data in |
| 26 | | X | PWM2 | Data out ALARM1 | Slave select - | Data in - |
| 27 | | X | PWM2 | Data out PWM1 | Slave select - | Data in - |

Table 3: Output configurations overview

The ZMD31050 provides the following I/O pins: OUT, IO1, IO2 and SDA.

Via these pins the following signal formats can be output: Analog (voltage/current), PWM, Data (SPI/I²C), Alarm.

The following values can be provided at the O/I pins: bridge sensor signal, temperature signal 1, temperature signal 2, alarm.

Note:

The Alarm signal only refers to the bridge sensor signal, but never to a temperature signal.

Due to the necessary pin sharing there are restrictions to the possible combinations of outputs and interface connections.

The table beside gives an overview about possible combinations.

Note:

In the SPI mode the pin IO2 is used as Slave select. Thus no Alarm 2 can be output in this mode.

ZMD31050 RB^{IC} series

Advanced Differential Sensor Signal Conditioner

Datasheet

PRELIMINARY

1.5.1. Serial Digital Interface

The ZMD31050 includes a serial digital interface which is able to communicate in three different communication protocols – I²CTM, SPITM and ZACwireTM (one wire communication). In the SPI mode the pin IO2 operates as slave select input, the pin IO1 as data output.

Initializing Communication

After power-on the interface is for about 20ms (start window) in the state ZACwire. During the start window it is possible to communicate via the one wire interface (pin OUT).

Detecting a proper request inside the start window the interface stays in the state ZACwire. This state can be left by certain commands or a new power-on.

If no request happens during the start window then the serial interface switches to I²C or SPI mode (depending on EEPROM settings) and the OUT pin is used as analog output or as PWM output (also depending on EEPROM settings).

The start window can generally be disabled (or enabled) by a special EEPROM setting.

1.5.2. ZACwireTM Single Wire Digital Interface

The ZMD31050 employs ZMD's ZACwireTM single wire digital interface concept. It combines a simple and easy protocol adaptation with a cost saving pin sharing.

Both the analog voltage output and digital interface (calibration and/or digital output value) occur over the same pin. An advantage of ZMD's ZACwireTM output signal capability is, that it enables "end of manufacture" calibration – no additional pins are required to digitally calibrate a finished assembly. This reduces cost and complexity.

The ZACWIRE interface is intended for calibration use only although the calibrated output signal is also available via this interface. The master slave configuration is shown below.

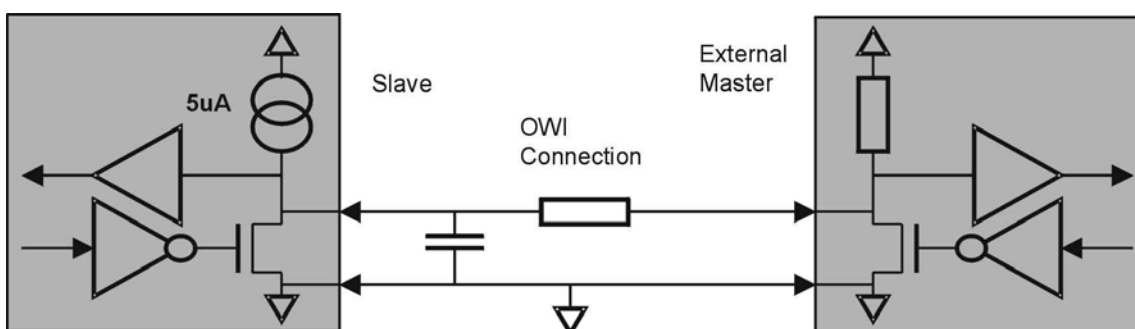

Fig. 6 Block scheme of ZACWIRE - connection

ZMD31050 RB^{IC} series

Advanced Differential Sensor Signal Conditioner

Datasheet

PRELIMINARY

Protocol Description

Both devices are peers, however only the external device starts communication and requests data, in this sense it is referred to as master and the ZMD31050 as slave.

Though ZACwire™ is designed as bilateral protocol, it is necessary for reasons of compatibility to use an address in the communication. After the start condition the master has to send an address-byte, consisting of a 7 bit slave address and a read/write-bit (0 – write, 1 – read). The slave-address of the ZMD31050 is 78hex, additionally 127 free programmable addresses (00hex to 7Fhex) are available.

General properties & Timing

BUS not busy: ZACWIRE line is pulled to HIGH in idle period.

Start - condition (START): A START will be recognized if a LOW-impulse on ZACWIRE follows a power on.

Stop- condition (STOP): A STOP will be recognized when no transition on ZACWIRE happens for at least about 250µs or twice the BIT – time of the last valid data bit, i.e. the time distance between the last two LOW-HIGH transitions. The master finishes every transmission by going back to HIGH (pull up). It can interrupt slave in read mode by holding down the ZACWIRE potential for the stop time.

Valid data: Data will be recognized whenever two LOW-HIGH transitions follow a start condition, when the length of the pulse is longer than 1/8 and shorter than 7/8 of the distance inbetween these LOW-HIGH transitions (t_{Bit}). Pulses of 1/8 to 3/8 t_{Bit} are defined as LOW, pulses of 5/8 to 7/8 t_{Bit} as HIGH.

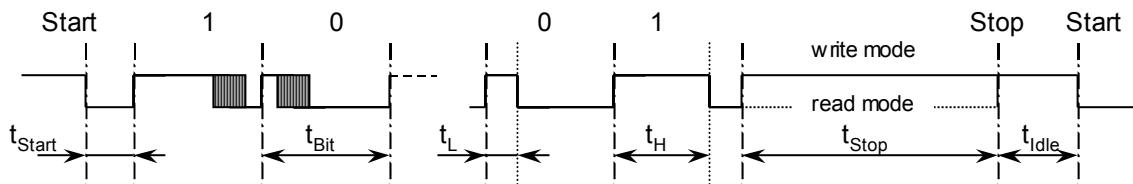

Fig. 7 Protocol Structure

Write operation: During transmission from master to slave (WRITE) the address byte follows a command byte. Depending on the transmitted command optional 2 data bytes are possible. The internal microprocessor evaluates the received command and processes the related routine.

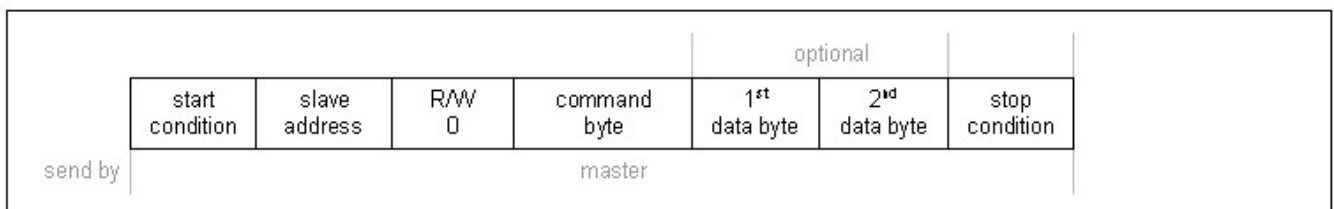

Fig. 8 Write operation

ZMD31050 RB^{IC} series

Advanced Differential Sensor Signal Conditioner

Datasheet

PRELIMINARY

Read operation: After a data request from master to slave (by sending an address byte including a set data direction bit) the slave answers by sending data from the activated interface output registers. The slave generates the data bits with a bit period equal to the last received bit (R/W bit). The master has to generate a stop condition after receiving the requested data.

A data request is answered by the interface module itself and does consequently not interrupt the current process of the internal microprocessor.

The data in the activated registers is sent continuously until a stop condition is detected. After transmitting all available data the slave starts repeating the data.

During running measurement cycle data is incessantly updated with conditioning results. To get other data from slave (e.g. EEPROM content) usually a certain command has to be sent before the data request to initiate the transfer of this data to the interface output registers. This command does interrupt the current process of the internal microprocessor and consequently also a running measurement cycle.

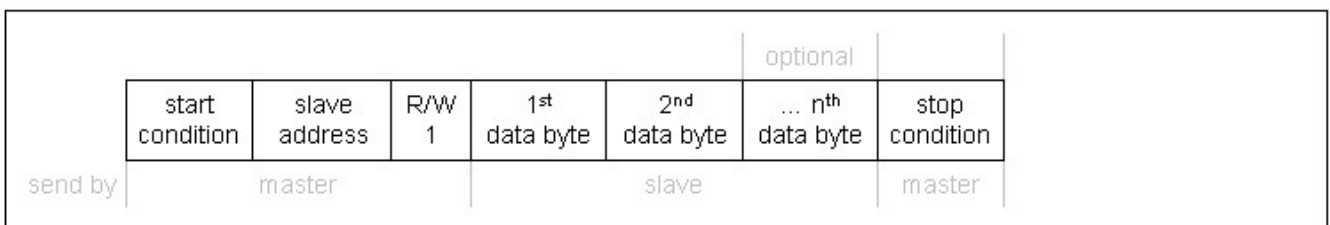

Fig. 9 Read operation - data request

1.5.3. Analog Output

For the analog output 3 registers of 12 bit depth are available, which can store the actual pressure and the results of temperature measurement 1 and 2. Each register can be independently switched to one of two output slots connected to the Pin OUT and IO1 respectively. In these output slots different output modules are available according to the following table:

| Output slot: | OUT | IO1 |
|--------------|-----|-----|
| Voltage | x | |
| PWM | x | x |

Table 5: Analog output configuration

The Voltage module consists of an 11bit resistor string - DAC with buffered output and a subsequent inverting amplifier with class AB rail-to-rail OPAMP. The two feedback nets are connected to the Pins FBN and FBP. This structure offers wide flexibility for the output configuration, for example voltage output and 4 to 20 mA current loop output.

The PWM module provides pulse streams with signal dependent duty cycle. The PWM - frequency depends on resolution and clock divider. The maximum resolution is 12 bit, the maximum PWM - frequency is 4 kHz (9 bit). If both, second PWM and SPI protocol are activated, the output pin IO1 is shared between the PWM output and the SPI_SDO output of the serial interface (Interface communication interrupts the PWM output).

ZMD31050 RB^{IC} series

Advanced Differential Sensor Signal Conditioner

Datasheet

PRELIMINARY

1.5.4. Comparator Module (ALARM Output)

The comparator module consists of two comparator channels connectable to IO1 and IO2 respectively. Each of them can be independently programmed referring to the parameters threshold, hysteresis, switching direction and on/off – delay, additional a window comparator mode is available.

1.6 Voltage Regulator

For ratiometric applications 3V to 5V (+/- 10%) the external supply voltage can be used for sensor element biasing. If an absolute analog output is desired then the internal voltage regulator with external power regulation element (FET) can be used. It is bandgap reference based and designed for an external supply range from $V_{dda} + 2V$ to 40V. With the voltage regulator the internal supply and sensor bridge voltage can be varied between 3V and 5V.

ZMD31050 RB^{IC} series

Advanced Differential Sensor Signal Conditioner

Datasheet

PRELIMINARY

1.7 Error Detection

A check of the sensor bridge for broken wires which is done permanently by two comparators watching the input voltage of each input (between 0.5V ... VDDA-0.5V).

This error states as well as the digital errors (CRC, parity) are indicated by forcing the output voltage into the diagnostic region, which is above 97.5% and below 2.5% of the VDDA supply. The following table shows the system response for different faults.

| Detected fault | Diagnostic level on analog out | Delay of detection |
|--------------------------------|--------------------------------|--------------------|
| Signature error of EEPROM | lower | 1ms |
| Parity error of RAM | lower | 1ms |
| Lost of bridge positive supply | upper | 1ms |
| Lost of bridge negative supply | upper | 1ms |
| Open bridge connection | upper | 1ms |

Table 6: System response for different diagnostic faults

The ZMD31050 detects various possible errors. A detected error is signaled by changing into a diagnostic mode. In this case the analog output is set to High or Low (maximum or minimum possible output value) and the output registers of the digital serial interface are set to a significant error code (see Table 7). Note that the error detection functionality (except the CRC-check regarding the EEPROM content) has to be enabled by configuration words.

| Detectable Error | Description | Sets SIF-Out to | Sets Analog Out to Diagnostic Mode |
|-----------------------------------|--|--|------------------------------------|
| CRC-Error | CRC-Check during read out of EEPROM after Power On or after SIF-Command COPY_EEP2RAM | CAAA | Low |
| RAM Parity Error | Parity-Check at every RAM access (Enabled by CFGAPP:SCCD) | CF0F | Low |
| Register Parity Error | Permanent Parity-Check of Configuration Registers (Enabled by CFGAPP:SCCD) | CE38 | Low |
| Sensor Connection | Connection-Check of Sensor Bridge (Enabled by CFGAPP:SCCD) | CFCF | High |
| Common Mode Voltage out of limits | Check if Bridge Common Mode Voltage is complies the programmed limits (Enabled by CFGCYC:ECMV) | E000 + V _{CM,13bit} V _{CM,13bit} : Measured Common Mode Voltage (13 significant Bits) | High |

Table 7: Error Codes

ZMD31050 RB^{IC} series

Advanced Differential Sensor Signal Conditioner

Datasheet

PRELIMINARY

2. Application Circuit Examples

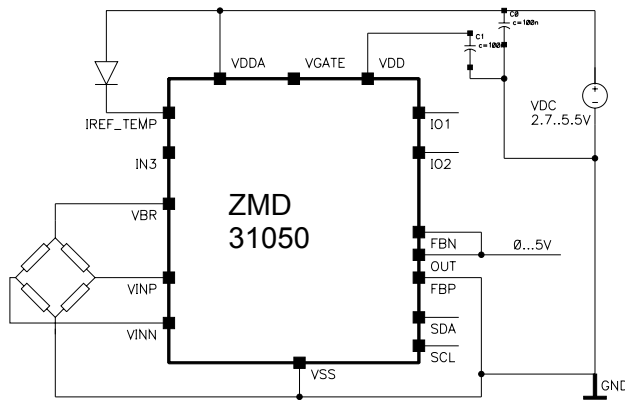

Example 1

Typical ratiometric measurement with voltage output, temperature compensation via external diode, internal vdd regulator and supply lost diagnosis (bridge must not be at Vdda) is used

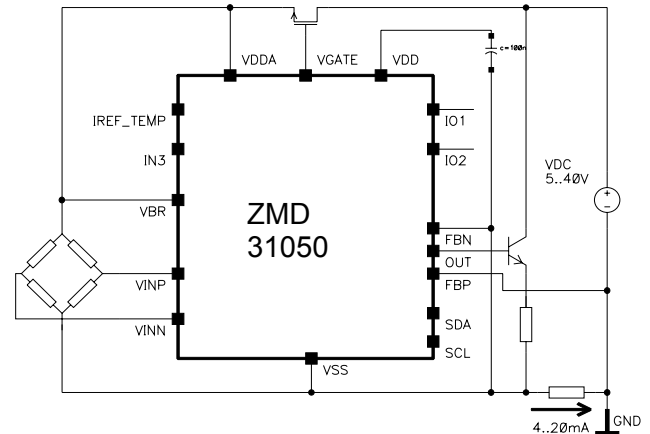

Example 2

True two wire 4...20mA (5...40V) configuration, voltage regulation using external JFET, internal temperature measurement, internal Vdd regulator is used

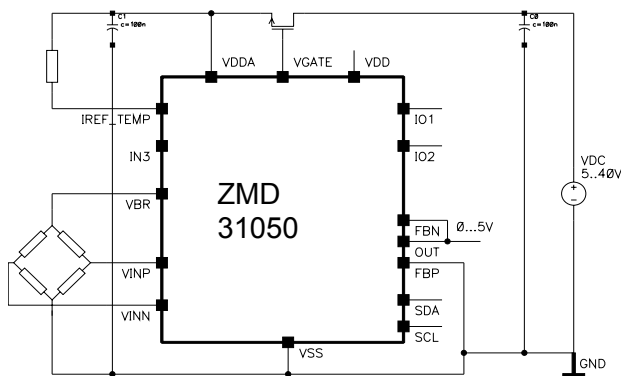

Example 3

Absolute voltage output, constant current biasing of the sensor bridge, temperature compensation by bridge voltage drop measurement

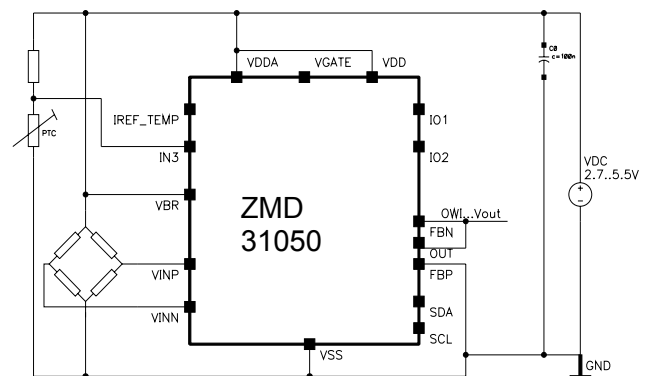

Example 4

Ratiometric measurement, 3-wire connection for end of line calibration of the sensor module, temperature measurement with external voltage divider incl. thermistor

3. ESD/Latch-Up-Protection

All Pins have an ESD Protection of >2000V (except the Pins INN,INP,FBP with > 1200V) and a Latch-up protection of $\pm 100\text{mA}$ or of +8V/ -4V (to VSS/VSSA).

ESD Protection referred to the human body model is tested with devices in SSOP16 packages during product qualification. The ESD test follows the human body model with 1.5kOhm/100pF based on MIL 883, Method 3015.7.

ZMD31050 RB^{IC} series

Advanced Differential Sensor Signal Conditioner

Datasheet

PRELIMINARY

4. Pin Configuration and Package

| Pin-No. | Name | Description | Remarks |
|---------|---------|--|---|
| 10 | OUT | Analog output & PWM1/Frequ. Output & one wire interface i/o | Analog output & dig. out after power on |
| 11 | FBP | Positive feedback connection output stage | Analog input/output |
| 9 | FBN | Negative feedback connection output stage & crystal connection pin for Frequ. Output | Analog input/output |
| 1 | VDDA | Positive analog supply voltage | Supply |
| 8 | VDD | Positive digital supply voltage | Supply |
| 15 | VSS | Negative supply voltage | Ground |
| 6 | SCL | I ² C clock & SPI clock | Digital input, pull-up |
| 7 | SDA | Data i/o for I ² C & data in for SPI | Digital input, pull-up |
| 14 | VINP | Positive input sensor bridge | Analog input |
| 16 | VINN | Negative input sensor bridge | Analog input |
| 13 | VBR | Bridge top sensing in bridge current out | Analog input/output |
| 2 | IN3 | Resistive temperature sensor input & external clock input | Analog input |
| 12 | IR_TEMP | Current source resistor i/o & temp. diode in | Analog in/out |
| 3 | VGATE | Gate voltage for external regulator FET | Analog output |
| 4 | IO1 | SPI data out & ALARM1 & PWM2 Output | Digital IO |
| 5 | IO2 | SPI chip select & ALARM2 | Digital IO |

The standard package of the ZMD31050 is a SSOP16 (5.3mm body width) with lead-pitch 0.65mm:

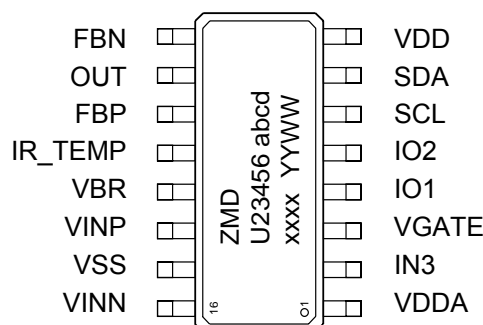

ZMD31050 RB^{IC} series

Advanced Differential Sensor Signal Conditioner

Datasheet

PRELIMINARY

5. IC Characteristics

5.1 Absolute Maximum Ratings

| No. | Parameter | Symbol | min | typ | max | Unit | Conditions |
|-------|--|---------------------|------|-----|-----------------|------|-----------------------|
| 5.1.1 | Digital Supply Voltage | V_{DDAMR} | -0.3 | | 6.5 | V | to VSS |
| 5.1.2 | Analog Supply Voltage | V_{DDAAMR} | -0.3 | | 6.5 | V | to VSS |
| 5.1.3 | Voltage at all analog and digital I/O - Pins | V_{INA}, V_{OUTA} | -0.3 | | $V_{DDA} + 0.3$ | V | Exception s. 5.1.4 |
| 5.1.4 | Voltage at Pin FBP | $V_{FBP,AMR}$ | -1.2 | | $V_{DDA} + 0.3$ | V | 4 .. 20mA – Interface |
| 5.1.5 | Storage temperature | T_{STG} | -45 | | 150 | °C | |

5.2 Operating Conditions

(Voltages related to VSS)

| No. | Parameter | Symbol | min | typ | max | Unit | Conditions |
|-------|--|--------------|----------------|-----|-----------|------------|---|
| 5.2.1 | Ambient temperature | T_{AMB} | -40 | | 125 | °C | |
| 5.2.2 | Ambient temperature advanced performance | T_{ADV} | -25 | | 85 | °C | |
| 5.2.3 | Analog Supply Voltage | V_{DDA} | 2.7 | | 5.5 | V | Ratiometric mode |
| 5.2.4 | Digital Supply Voltage | V_{DD} | .95 | | 1.05 | V_{DDA} | Uncontrolled Vdd mode |
| 5.2.5 | External Supply Voltage | V_{SUPP} | $V_{DDA} + 2V$ | | 40 | V | In voltage regulator mode with external JFET |
| 5.2.6 | Common mode input range | V_{INCM} | 0.25 | | 0.65 | V_{DDA} | absolute ratings in temperature range |
| 5.2.7 | Input Voltage Pin FBP | $V_{IN,FBP}$ | -1 | | V_{DDA} | V | |
| 5.2.8 | Sensor Bridge Resistance | R_{BR} | 3.0 5.0 | | 25.0 | k Ω | full temperature range 4 .. 20mA - Interface |
| 5.2.9 | Reference Resistor for Bridge Current Source | R_{REF} | 0.07 | | | R_{BR} | (leads to $I_{BR} = V_{DDA} / (16 \cdot R_{REF})$) |

ZMD31050 RB^{IC} series

Advanced Differential Sensor Signal Conditioner

Datasheet

PRELIMINARY

| | | | | | | | |
|--------|-----------------------------------|------------|----|-----|-----|------------|--|
| 5.2.10 | Stabilization Capacitor | C_{VDDA} | 50 | 100 | 470 | nF | between VDDA and VSS, extern |
| 5.2.11 | Optional Stabilization Capacitor | C_{VDD} | 0 | 100 | 470 | nF | between VDD and VSS, extern |
| 5.2.12 | Maximum allowed load capacitance* | C_{Lout} | | | 50 | nF | Voltage mode |
| 5.2.13 | Minimum allowed load resistance | R_{Lout} | 5 | | | k Ω | Voltage mode |
| 5.2.14 | Minimum allowed load resistance | R_{Lout} | 2 | | | k Ω | 0.5...4.5V mode, without supply voltage lost diagnosis |

5.3 Build In Characteristics

| No. | Parameter | Symbol | min | typ | max | Unit | Conditions |
|--------|---|-------------|-------|------|-------|----------------|-----------------------------------|
| 5.3.1. | Selectable Input Span, Pressure Measurement | V_{INSP} | 1 | | 275 | mV/V | (4 Bit setting s. 3.3.1) |
| 5.3.2 | Selectable AnalogOffset Compensation Range | | -300% | | +300% | V InputSpan | (6 Bit Settling in 10% Steps) |
| 5.3.3 | A/D Resolution | RES_{AD} | 9 | | 15 | Bit | (3 Bit setting) |
| 5.3.4 | D/A Resolution | RES_{DA} | | 11 | | Bit | Voltage or Current Output |
| 5.3.5 | PWM - Resolution | RES_{PWM} | 9 | | 12 | Bit | |
| 5.3.6 | Reference current for external temperature diodes | I_{TSE} | 12 | 16 | 25 | μ A | |
| 5.3.7 | Sensitivity internal temperature diode | $S_{T,TSI}$ | 2800 | 3200 | 3600 | ppm f.s. /K | Raw values - without conditioning |

* if used, consider special requirements of OWI single wire interface stated in Appendix A

ZMD31050 RB^{IC} series

Advanced Differential Sensor Signal Conditioner

Datasheet

PRELIMINARY

5.3.8 Cycle Rate versus A/D-Resolution

(linear related to master clock frequency* - values calculated at exact 2 MHz)

| ADC Order | Resolution | Conversion Cycle f_{con} |
|-----------|------------|----------------------------|
| | Bit | Hz |
| 1 | 9 | 1302 |
| | 10 | 781 |
| | 11 | 434 |
| | 12 | 230 |
| | 13 | 115 |
| | 14 | 59 |
| 2 | 15 | 30 |
| | 11 | 3906 |
| | 12 | 3906 |
| | 13 | 1953 |
| | 14 | 1953 |
| | 15 | 977 |

5.3.9 PWM Frequency

| PWM | PWM Freq./Hz at 2 MHz Dig. Clock* | | | |
|------------|-----------------------------------|------|------|-------|
| Resolution | Clock Divider | | | |
| Bit | 1 | 0,5 | 0,25 | 0,125 |
| 9 | 3906 | 1953 | 977 | 488 |
| 10 | 1953 | 977 | 488 | 244 |
| 11 | 977 | 488 | 244 | 122 |
| 12 | 488 | 244 | 122 | 61 |

- Internal RC – Oszillator programmable with 1,2,4 MHz +/- 25% , external clock is also possible

ZMD31050 RB^{IC} series

Advanced Differential Sensor Signal Conditioner

Datasheet

PRELIMINARY

5.4 Electrical Parameters

(Voltages related to VSS)

| No. | Parameter | Symbol | min | typ | max | Unit | Conditions |
|--|--|-----------------|-----------|--------|---------|---------------|--|
| 5.4.1 Supply / Regulation | | | | | | | |
| 5.4.1.1 | Supply current | I_{SUM} | | 2.2 | 2.5 | mA | without bridge current and without load current, $f_{clk} \leq 2.2\text{MHz}$ |
| 5.4.1.2 | Temperature Coeff. Voltage Reference 1 | TC_{REF} | -200 | +/- 50 | 200 | ppm/K | |
| 5.4.2 Analog Front End | | | | | | | |
| 5.4.2.1 | Parasitic differential input offset current1 | I_{IN} | -2 -10 | | 2 10 | nA | temp. range 5.2.2., T_{ADV} |
| 5.4.3 DAC & Analog Output (Pin OUT) | | | | | | | |
| 5.4.3.1 | Signal output range | V_{OUT} | 0.025 | | 0.975 | V_{DDA} | Voltage mode |
| 5.4.3.2 | Slew rate ¹ | SR_{OUT} | 0.1 | | | V/ μ s | Voltage mode, $C_L < 20\text{nF}$ |
| 5.4.3.3 | Short circuit current limitation | $I_{max_{OUT}}$ | 5 | 10 | 20 | mA | |
| No. | Parameter | Symbol | min | typ | max | Unit | Conditions |
| 5.4.4 PWM Output (Pin OUT, IO1) | | | | | | | |
| 5.4.4.1 | PWM high voltage | PWM_{VH} | 0.9 | | | V_{DDA} | $R_L > 10\text{ k}\Omega$ |
| 5.4.4.2 | PWM low voltage | PWM_{VL} | | | 0.1 | V_{DDA} | $R_L > 10\text{ k}\Omega$ |
| 5.4.4.3 | PWM output slope ¹ | PWM_{SL} | 15 | | | V/ μ s | $C_L < 1\text{nF}$ |
| 5.4.5 Temperature Sensors (Output IRT) | | | | | | | |
| 5.4.5.1 | Sensitivity external diode or resistor meas. | ST_{TSE} | 1450 | 1520 | 1590 | ppm f.s. / mV | Raw values - without conditioning |
| 5.4.6 Digital Outputs (IO1, IO2, OUT in digital mode) | | | | | | | |
| 5.4.6.1 | Output-High-Level | $V_{OUTP,H}$ | 0.9 | | | V_{DDA} | |
| 5.4.6.2 | Output-Low-Level | $V_{OUTP,L}$ | | | 0.1 | V_{DDA} | |
| 5.4.6.3 | Output Current ¹ | I_{OUTP} | 4 | | | mA | |

¹ no measurement in serial production, parameter is guaranteed by design and/or quality observation

ZMD31050 RB^{IC} series

Advanced Differential Sensor Signal Conditioner

Datasheet

PRELIMINARY

| 5.4.7 System Response | | | | | | | |
|-----------------------|---------------------------|-----------|-------------|--|---------------|-----|--|
| 5.4.7.1 | Setup time* ¹ | t_{IN} | 2 | | 5 | ms | Power up to first measure result at output, without OWI – start window |
| 5.4.7.2 | Response time | t_{RES} | $2/f_{CON}$ | | $3/f_{CON}$ | | |
| 5.4.7.2 | Overall accuracy | OA | | | 0.1% 0.25% | | Deviation from ideal line including INL, gain and offset errors -25...+85°C oper. temp. -40...+125°C op. temp. |
| 5.4.7.3 | Peak-to-Peak-Noise@output | | | | 5 | mV | shorted inputs, bandwidth ≤ 2 kHz |
| 5.4.7.4 | Ratiometricity Error | RE | | | 500 | ppm | ratiometric input signals |

* Depends on resolution and configuration - start routine begins approximately 0.8ms after power on

5.5 Interface Characteristics

| 5.5.1 Multiport Serial Interfaces (I ² C, SPI) | | | | | | | |
|---|---------------------------|----------------|------|--|------|------------------------|--------------------------------|
| 5.5.1 | Input-High-Level | V_{IH} | 0.7 | | 1 | V_{DDA} | |
| 5.5.2 | Input-Low-Level | V_{IL} | 0 | | 0.3 | V_{DDA} | |
| 5.5.3 | Output-Low-Level | V_{OL} | | | 0.1 | V_{DDA} | Open-Drain, $I_{OL} = -3$ mA |
| 5.5.4 | LO SDA | $C_{L,SDA}$ | | | 400 | pF | |
| 5.5.5 | Clock frequency SCL | f_{SCL} | | | 400 | kHz | |
| 5.5.2 One Wire Serial Interface (ZACwire) | | | | | | | |
| 5.5.1 | Pull up resistance master | $R_{OWI,pu}$ | 330 | | | Ω | |
| 5.5.2 | OWI line resistance | $R_{OWI,line}$ | | | 0.05 | $R_{OWI,pu}$ | |
| 5.5.3 | OWI load capacitance | $C_{OWI,load}$ | | | 0.08 | $t_{BIT} / R_{OWI,pu}$ | $20\mu s < t_{BIT} < 100\mu s$ |
| 5.5.4 | Voltage level Low | $V_{OWI,low}$ | | | 0.2 | V_{DD} | |
| 5.5.5 | Voltage level High | $V_{OWI,high}$ | 0.75 | | | V_{DD} | |

ZMD31050 RB^{IC} series

Advanced Differential Sensor Signal Conditioner

Datasheet

PRELIMINARY

6. Test

Parameters given in this specification are design objectives. Final parameters which will be tested during series production will be specified by ZMD after investigations in the engineering samples. The resulting data sheet includes all parameters which will be tested by ZMD. The test program is based on this data sheet. The fulfillment of the test specification is obligatory to deliver and obligates to purchase.

Measurements at corner temperatures (-40°C, 125°C) cannot be taken. The ASIC will be tested at room temperature in mass production.

7. Reliability

A reliability investigation according to the in-house non-automotive standard will be performed.

8. Customization

For high-volume applications, which require an up- or downgraded functionality compared to the ZM31050, ZMD can customize the circuit design by adding or removing certain functional blocks. For it ZMD has a considerable library of sensor-dedicated circuitry blocks. Thus ZMD can provide a custom solution quickly. Please contact ZMD for further information.

9. Related Documents

- ZMD31050 Feature Sheet
- ZMD31050 Functional Description

ZMD31050 RB^{IC} series

Advanced Differential Sensor Signal Conditioner

Datasheet

PRELIMINARY

10. Ordering Information

| Ordering Code | Description | Operating Temperature Range | Package Type | Device Marking | Shipping Form |
|---------------|---|-----------------------------|-------------------|----------------|--|
| ZMD31050AB | Dice on tested unsawn wafer | -40 ... +125°C** | die | | 6" wafer |
| ZMD31050AC | Dice on tested sawn wafer | -40 ... +125°C** | die | | 6" wafer on frame |
| ZMD31050AD | Dice in waffle tray | -40 ... +125°C** | die | | Waffle tray * (100 dice / tray) |
| ZMD31050AF-T | Finished parts in tube | -40 ... +125°C | SSOP16 (5.3mm) | ZMD31050AF | Tube * (77 parts / tube) |
| ZMD31050AF-R | Finished parts in tape on reel | -40 ... +125°C | SSOP16 (5.3mm) | ZMD31050AF | Tape on reel * (2000 parts / reel) |
| ZMD31050AF-S | Finished parts in sample box | -40 ... +125°C | SSOP16 (5.3mm) | ZMD31050AF | Sample box * (5 parts / box) |
| ZMD31050AK | Application kit for sensor calibration and evaluation | | | | Box, containing calibration board, CD-ROM, 5 samples (SSOP16) |

* The quantity ordered should be a multiple of the quantity / packing unit as specified

** -50...+150°C derated

The information furnished here by ZMD is believed to be correct and accurate. However, ZMD shall not be liable to any licensee or third party for any damages, including, but not limited to, personal injury, property damage, loss of profits, loss of use, interruption of business or indirect, special, incidental, or consequential damages of any kind in connection with or arising out of the furnishing, performance, or use of this technical data. No obligation or liability to any licensee or third party shall result from ZMD's rendering of technical or other services.

For further information:

ZMD Stuttgart Office
 Nord-West-Ring 34
 70974 Filderstadt - Bernhausen
 Tel.: +49 (0)711.674.517-0
 Fax: +49 (0)711.674.517-99
 sales@zmd.de
 www.zmd.biz

ZMD AG
 Grenzstrasse 28
 01109 Dresden, Germany
 Tel.: +49 (0)351.8822.310
 Fax: +49 (0)351.8822.337
 sales@zmd.de
 www.zmd.biz

ZMD America Inc.
 201 Old Country Road, Suite 204
 Melville, NY 11747
 Tel.: (631) 549-2666
 Fax: (631) 549-2882
 sensors@zmda.com
 www.zmd.biz