

Actual Size = 5 x 7mm



Product Features

- 3.3V or 5V AC MOS/TTL compatible logic levels
- Very tight frequency stability available
- Fast clock edge rate
- Pin-compatible with standard 5x7mm packages
- Designed for standard reflow and washing techniques
- Pb-free and RoHS/Green compliant

Product Description

The S19xx Series is a 3.3V or 5V crystal clock oscillator that achieves superb stability and fast rise/fall edges over a broad range of operating conditions and frequencies. The output clock signal, generated internally with a PLL oscillator design, is compatible with AC MOS/TTL logic levels. The device, available on tape and reel, is contained in a 5x7mm surface-mount ceramic package.

Applications

The S19xx Series is an ideal reference clock for high-speed applications requiring tight stability, including:

- T1 / E1 line cards
- T3 / E3 line cards
- Network processors
- Industrial controls



Packaging Outline

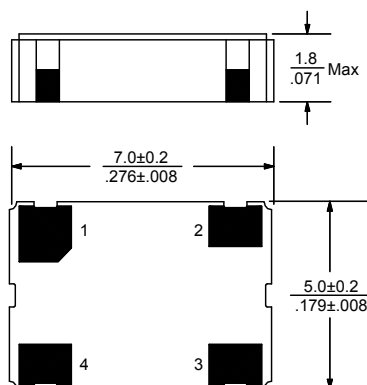

Pin Functions

Pin	Function
1	OE Function
2	Ground
3	Clock Output
4	V _{DD}

Common Frequencies

Contact SaRonix for additional frequencies

32.7680 MHz	49.1520 MHz	80.0000 MHz
35.3280 MHz	54.0000 MHz	90.0000 MHz
38.8800 MHz	60.0000 MHz	98.3040 MHz
40.0000 MHz	61.4400 MHz	108.0000 MHz
44.7360 MHz	66.0000 MHz	120.0000 MHz
45.0000 MHz	76.8000 MHz	122.8800 MHz
48.0000 MHz	77.7600 MHz	

Ordering Information

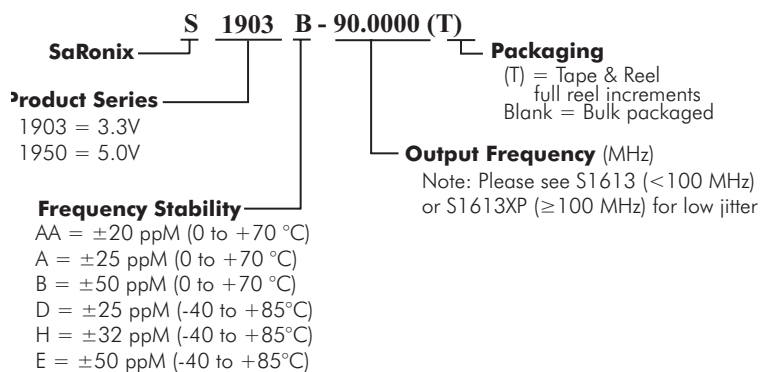

Electrical Performance

Parameter	Min.	Typ.	Max.	Units	Notes
Output frequency (S1903)	32		125	MHz	As specified
Output frequency (S1950)	80		125	MHz	As specified
Supply voltage	+2.97	+3.3	+3.63	V	
Supply current (S1903)			35	mA	
Supply current (S1950)		35	50	mA	
Frequency stability			±20 to ±50	ppM	See Note 1 below
Operating temperature	-40		+85	°C	As specified
Output logic 0, VOL (S1903)			20% V _{DD}	V	
Output logic 0, VOL (S1950)			10% V _{DD}	V	
Output logic 1, VOH	80% V _{DD}			V	
Output load (S1903)			95	Ω	AC (ACMOS)
Output load (S1950)			50	Ω	AC (ACMOS)
Duty cycle (S1903)	45		55	%	-40 to +85°C measured 50%VDD
Duty cycle (S1950)	40		60	%	-40 to +85°C measured 50%VDD or 1.5V
Duty cycle (S1950)	45		55	%	0 to +70°C measured 50%VDD
Rise and fall time			2	ns	measured 20/80% of waveform
Jitter, total			80	ps pk-pk	up to 72 MHz
Jitter, total			120	ps pk-pk	>72 MHz 0 to 70°C
Jitter, total			150	ps pk-pk	>72 MHz -40 to +85°C

Notes:

- As specified. Stability includes all combinations of operating temperature, load changes, rated input (supply) voltage changes, initial calibration tolerance (25°C), aging (1 year at 25°C average effective ambient temperature), shock and vibration.

Output Enable / Disable Function

Parameter	Min.	Typ.	Max.	Units	Notes
Input Voltage (pin 1), Output Enable	2.2			V	or open
Input voltage (pin 1), Output Disable			0.8	V	Output is Hi-Z
Internal pullup resistance	50			kΩ	
Output disable delay			100	ns	
Output enable delay			100	ns	

Typical Phase Noise

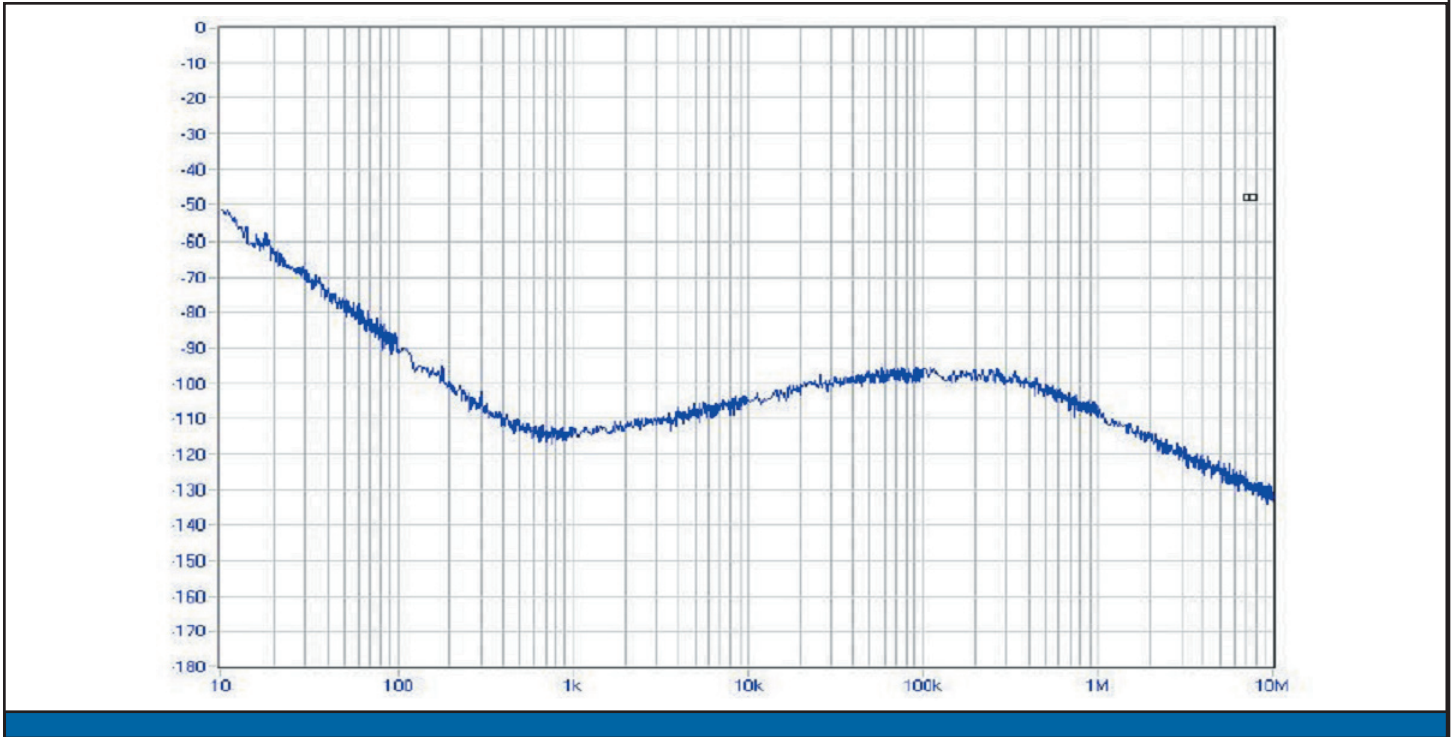

Absolute Maximum Ratings

Parameter	Min.	Typ.	Max.	Units	Notes
Storage temperature	-55		+125	°C	
Supply Voltage			+7	V	

Test Circuit

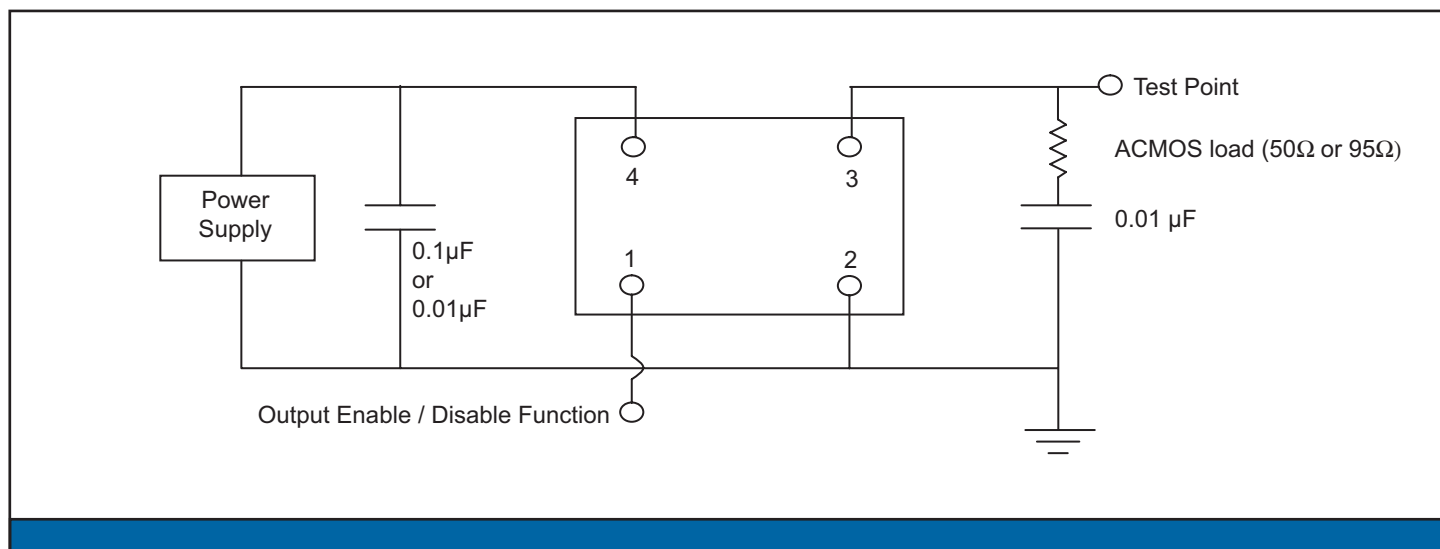

Reliability Test Ratings

This product is rated to meet the following test conditions:

Type	Parameter	Test Condition
Mechanical	Shock	MIL-STD-883, Method 2002, Condition B
Mechanical	Solderability	JESD22-B102-D Method 2 (Preconditioning E)
Mechanical	Terminal strength	MIL-STD-883, Method 2004, Condition D
Mechanical	Gross leak	MIL-STD-883, Method 1014, Condition C
Mechanical	Fine leak	MIL-STD-883, Method 1014, Condition A2 ($R_1 = 2 \times 10^{-8}$ atm cc/s)
Mechanical	Solvent resistance	MIL-STD-202, Method 215
Environmental	Thermal shock	MIL-STD-883, Method 1011, Condition A
Environmental	Moisture resistance	MIL-STD-883, Method 1004
Environmental	Vibration	MIL-STD-883, Method 2007, Condition A
Environmental	Resistance to soldering heat	J-STD-020C Table 5-2 Pb-free devices (2 cycles max)

Output Waveform

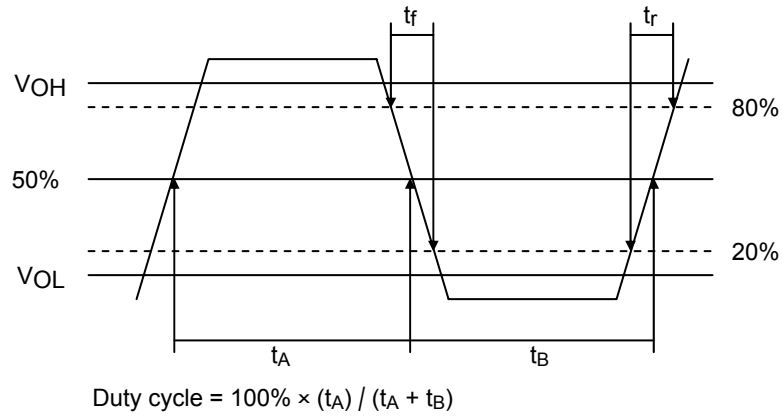

Reflow Soldering Profile

As per IPC/JEDEC J-STD-020C

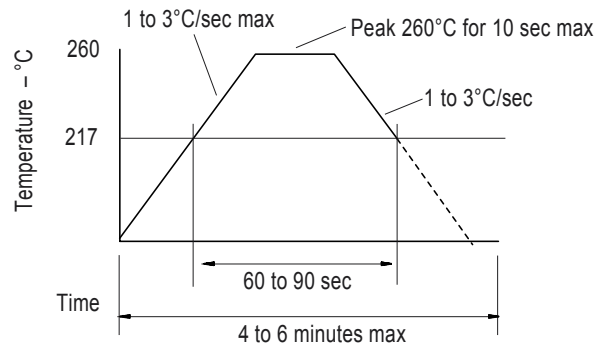

Mechanical Drawings

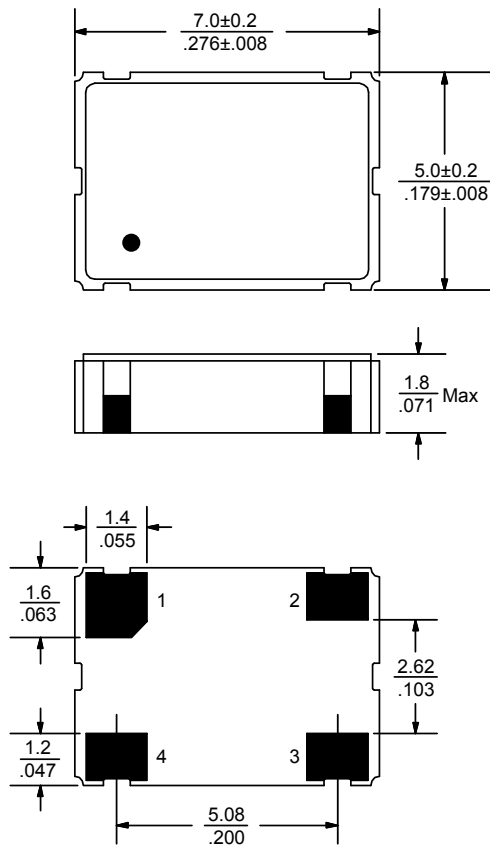

Recommended Land Pattern*

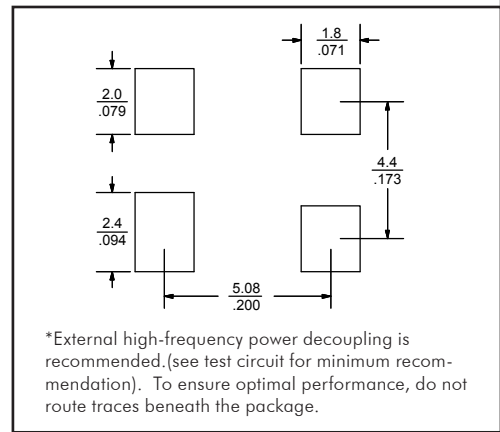

Scale: None. Dimensions are in mm/inches.

Marking LINE 1: S X X (SaRonix, Model (D=S1903, H=S1950), Stability code)
Marking LINE 2: Frequency (Frequency code)
Marking LINE 3: ● YY WW X (Pin 1, Year, Week, Origin)

**Exact location of markings may vary.