

Improved Industry Standard CMOS 12-Bit Multiplying DAC

FEATURES

- Improved Direct Replacement for AD7541A and AD7541
- 4-Quadrant Multiplication
- **12-Bit End-Point Linearity: $\pm 0.5\text{LSB}$ DNL and INL Over Temperature**
- All Grades Guaranteed Monotonic
- **Maximum Gain Error: $\pm 1\text{LSB}$**
- Single 5V to 15V Supply
- TTL and CMOS Logic Compatible
- Reduced Sensitivity to Op Amp Offset
- Low Power Consumption
- Virtually Latch-Up Proof
- Low Cost

APPLICATIONS

- Motion Control Systems
- Microprocessor-Controlled Calibration
- Automatic Test Equipment
- Programmable Gain Amplifiers
- Digitally Controlled Filters

DESCRIPTION

The LTC[®]7541A is a 12-bit resolution multiplying digital-to-analog converter (DAC).

Laser-trimmed thin-film resistors provide excellent absolute accuracy. Precision matched resistors and CMOS circuitry result in remarkable stability with temperature and supply variations.

The LTC7541A is a superior pin compatible replacement for the industry standard AD7541A/AD7541. Improvements include better accuracy and stability and reduced sensitivity to output amplifier offset. The LTC7541A is also very resistant to latch-up.

In addition to 2-quadrant and 4-quadrant multiplying configurations, the LTC7541A performs well in digitally programmable gain and noninverting voltage output applications. Low cost, improved performance and versatility make the LTC7541A the best choice for many new designs and for upgrading existing systems. Parts are available in 18-pin PDIP and 18-pin SO Wide packages.

LT, LTC and LT are registered trademarks of Linear Technology Corporation.

TYPICAL APPLICATION

**2-Quadrant Multiplying DAC Has Less Than
0.5LSB (Typ) Total Unadjusted Error**

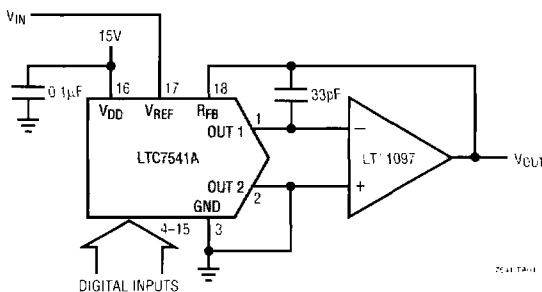

Integral Nonlinearity Over Temperature

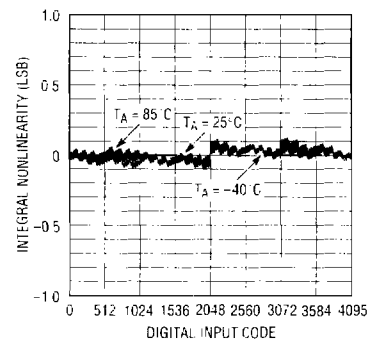

9241F-02

ABSOLUTE MAXIMUM RATINGS

V _{DD} to GND	-0.5V to 17V
V _{REF} to GND	±25V
R _{FB} to GND	±25V
Digital Inputs to GND	-0.5V to (V _{DD} + 0.5V)
OUT 1, OUT 2 to GND	-0.5V to (V _{DD} + 0.5V)
Power Dissipation	450mW
(Derate 6mW/°C Above 75°C)	
Maximum Junction Temperature	-65°C to 125°C
Operating Temperature Range	
Commercial (J, K Versions)	0°C to 70°C
Industrial (B Version)	-40°C to 85°C
Storage Temperature Range	-65°C to 150°C
Lead Temperature (Soldering, 10 sec)	300°C

PACKAGE/ORDER INFORMATION

	ORDER PART NUMBER LTC7541ABN LTC7541ABSW LTC7541AJN LTC7541AKN LTC7541AJSW LTC7541AKSW
N PACKAGE 18-LEAD PDIP T _{JMAX} = 150°C, θ _{JA} = 100°C/W (N) T _{JMAX} = 150°C, θ _{JA} = 130°C/W (SW)	SW PACKAGE 18-LEAD PLASTIC SO WIDE T _{JMAX} = 150°C, θ _{JA} = 100°C/W (N) T _{JMAX} = 150°C, θ _{JA} = 130°C/W (SW)

Consult factory for Military grade parts.

ELECTRICAL CHARACTERISTICS

V_{DD} = 15V, V_{REF} = 10V, OUT 1 = OUT 2 = GND = 0V, T_A = T_{MIN} to T_{MAX}, unless otherwise specified.

SYMBOL	PARAMETER	CONDITIONS	LTC7541AJ			LTC7541AK/LTC7541AB			UNITS	
			MIN	TYP	MAX	MIN	TYP	MAX		
Accuracy										
	Resolution		●	12		12			Bits	
INL	Integral Nonlinearity (Relative Accuracy)	(Note 1)	●		±1		±0.5		LSB	
DNL	Differential Nonlinearity	Guaranteed Monotonic. T _{MIN} to T _{MAX}	●		±1		±0.5		LSB	
GE	Gain Error	(Note 2) T _A = 25°C T _{MIN} to T _{MAX}	●		±6		±1		LSB	
			●		±8		±2		LSB	
	Gain Temperature Coefficient	(Note 3)	●	1	5		1	5	ppm/°C	
I _{LKG}	Output Leakage Current	(Note 4) T _A = 25°C T _{MIN} to T _{MAX}	●		±5		±5		nA	
			●		±10		±10		nA	
PSRR	Power Supply Rejection	V _{DD} = 15V ±5%	●		±0.002		±0.002		%/%	
Reference Input										
R _{REF}	V _{REF} Input Resistance		●	7	11	15	7	11	15	kΩ
	V _{REF} Input Resistance Temperature Coefficient				-100		-100		ppm/°C	
Power Supply										
V _{DD}	Operating Supply Range		●	5	15	16	5	15	16	V
I _{DD}	Supply Current	Digital Inputs = V _{IH} or V _{IL}	●			2		2		mA
		Digital Inputs = 0V or V _{DD}	●			100		100		µA
Digital Inputs										
V _{IH}	Digital Input High Voltage		●	2.4		2.4			V	
V _{IL}	Digital Input Low Voltage		●		0.8		0.8		V	
I _{IN}	Digital Input Current		●	0.001	±1		0.001	±1	µA	
C _{IN}	Digital Input Capacitance	(Note 3), V _{IN} = 0V	●		8		8		pF	

6

ELECTRICAL CHARACTERISTICS

$V_{DD} = 15V$, $V_{REF} = 10V$, $OUT\ 1 = OUT\ 2 = GND = 0V$, $T_A = T_{MIN}$ to T_{MAX} , unless otherwise specified.

SYMBOL	PARAMETER	CONDITIONS	ALL GRADES			UNIT
			MIN	TYP	MAX	
AC Performance						
	Propagation Delay	(Notes 5, 6)		100		ns
	Digital-to-Analog Glitch Impulse	(Notes 5, 7)		1000		nV-sec
	Multiplying Feedthrough Error	$V_{REF} = \pm 10V$, 10kHz Sine Wave		1.0		mV _{P-P}
	Output Current Settling Time	(Note 5), To 0.01% for Full-Scale Change		0.6		μ s
C_{OUT}	Output Capacitance (Note 3)	Digital Inputs = V_{IH}	C_{OUT1}	●	200	ρ F
			C_{OUT2}	●	70	ρ F
		Digital Inputs = V_{IL}	C_{OUT1}	●	70	ρ F
			C_{OUT2}	●	200	ρ F

The ● denotes specifications which apply over the full operating temperature range.

Note 1: $\pm 0.5LSB = \pm 0.012\%$ of full scale.

Note 2: Using internal feedback resistor.

Note 3: Guaranteed by design, not subject to test.

Note 4: I_{OUT1} with all digital inputs = 0V or I_{OUT2} with all digital inputs = V_{DD} .

Note 5: OUT 1 load = 100Ω in parallel with $13pF$.

Note 6: Measured from digital input change to 90% of final analog value. Digital inputs = 0V to V_{DD} or V_{DD} to 0V.

Note 7: $V_{REF} = 0V$. All digital inputs 0V to V_{DD} or V_{DD} to 0V. Measured using LT1363 as output amplifier.

TYPICAL APPLICATIONS

Unipolar Operation (2-Quadrant Multiplication)

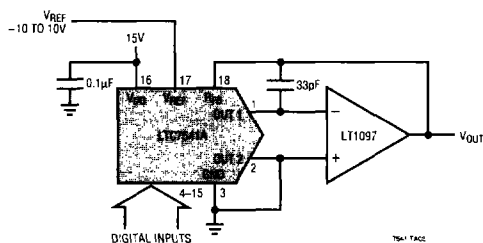

Table 1. Unipolar Binary Code Table

DIGITAL INPUT			ANALOG OUTPUT
MSB	LSB		V_{OUT}
1111	1111	1111	$-V_{REF}$ (4095/4096)
1000	0000	0000	$-V_{REF}$ (2048/4096) = $-V_{REF}/2$
0000	0000	0001	$-V_{REF}$ (1/4096)
0000	0000	0000	0V

Bipolar Operation (4-Quadrant Multiplication)

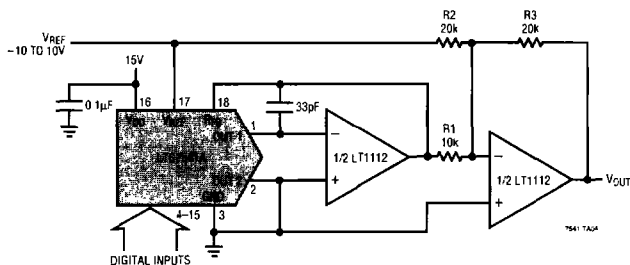
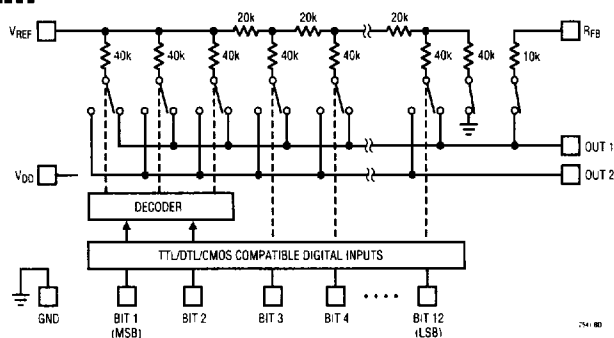

Table 2. Bipolar Offset Binary Code Table

DIGITAL INPUT			ANALOG OUTPUT
MSB	LSB		V_{OUT}
1111	1111	1111	V_{REF} (2047/2048)
1000	0000	0001	V_{REF} (1/2048)
1000	0000	0000	0V
0111	1111	1111	$-V_{REF}$ (1/2048)
0000	0000	0000	$-V_{REF}$

BLOCK DIAGRAM



RELATED PARTS

PART NUMBER	DESCRIPTION	COMMENTS
LTC1257	Complete Serial I/O V_{OUT} 12-Bit DAC	5V to 15V Single Supply in 8-Pin SO and PDIP
LTC1451/LTC1452/LTC1453	Complete Serial I/O V_{OUT} 12-Bit DACs	Rail-to-Rail V_{OUT} . 3V/5V Single Supply in 8-Pin SO and PDIP
LTC7543/LTC8143	Serial I/O Multiplying I_{OUT} 12-Bit DACs	Clear Pin, Serial Data Output (LTC8143)
LTC8043	Serial I/O Multiplying I_{OUT} 12-Bit DAC	8-Pin SO and PDIP