

**SIMATIC S5**

**IP 267  
Stepper Motor Controller**

**Manual**

**EWA 4NEB 812 6061-02a**

[www.DataSheet4U.net](http://www.DataSheet4U.net)

SIMATIC® and STEP ® are registered trademarks of Siemens AG.

Copyright © Siemens AG 1989

Subject to change without prior notice.

The reproduction, transmission or use of this document or its contents is not permitted without express written authority.

Offenders will be liable for damages. All rights including rights created by patent grant or registration of a utility model or design, are reserved.

**Preface**

---

**Introduction**

---

**System Overview**

**1**

**Driving Stepper Motors with the IP 267**

**2**

**Module Description**

**3**

**Addressing and Programming**

**4**

**Notes on Operation**

**5**

**Application Examples**

**6**

**Function block for assigning parameters to the IP 267**

**7**

**Index**

---

## Preface

The IP 267 intelligent I/O module generates programmable pulse trains for driving the power sections of stepper motors. The IP 267 has separate digital inputs for controlling positioning movements and signalling certain events to the CPU. The IP 267 can only be used in conjunction with programmable controllers of the S5-100U range. It operates with the following CPUs:

- CPU 100 (6ES5 100 - 8MA02 only)
- CPU 102 (without restrictions)
- CPU 103 (without restrictions).

The IP 267 processes all the input and output signals necessary for approaching the required positions autonomously in an application-specific integrated circuit (ASIC). The CPU can, in the meantime, scan all signals present and communicate with the I/O modules. The control actions in the IP 267 do not load the CPU.

Since the IP 267 is only used in conjunction with the S5-100U, this manual presupposes you are familiar with the manual of the programmable controller. The basics of STEP 5 programming and the principles of program execution are therefore not described here.

The application examples in Chapter 6 are intended to help you familiarize yourself with the module. However, the IP 267 is used in a wide range of applications so that it is impossible to discuss all the problems that might occur in day-to-day use. Should you have problems, please contact your nearest SIEMENS representative.

## Introduction

The following pages contain information which will help you to use this manual.

### Description of contents

The manual covers the following topics:

- System Overview  
(functional description, schematic diagram)
- Driving Stepper Motors with the IP 267  
(fundamental terms of stepper motor control, description of the configuration data)
- Module Description  
(technical specifications, power supply, input and output signals, terminal assignments, status displays, connecting cables for power sections)
- Addressing and Programming  
(address assignment of the configuration message frames, positioning message frames and feedback message frames, flowchart)
- Notes on Operation  
(preparing the module, system startup, determining reference points, motor selection, diagnostics sheet)
- Application Examples  
(program examples for various applications)
- FB for assigning parameters to the IP 267

At the end of the book, you will find correction forms. Please enter any suggestions you may have in the way of improvements or corrections in this form and send it to us. Your comments will help us to improve the next edition.

## Courses

Siemens provide SIMATIC S5 users with extensive opportunities for training. For more information, please contact your Siemens representative.

## Reference literature

This manual is a comprehensive description of the IP 267 stepper motor controller. Other topics of the SIMATIC® S5 range are only briefly dealt with. You will find more detailed information in the following literature:

- **Programming primer for the SIMATIC® S5-100U**

Practical Exercises with the PG 615 Programmer

Siemens AG, Berlin and Munich, 1988

Contents:

- Design and installation of the S5-100U programmable controller
- Introduction to programming with the PG 615

Order No.: ISBN 3-8009-1528-6

- **Speicherprogrammierbare Steuerungen SPS** (available in Germany only)

Volume1: Logic and sequential controls, from the control problem to the control program.

Günter Wellenreuther, Dieter Zastrow  
Braunschweig 1987

Contents:

- How a programmable controller works
- The theory of logic control using the STEP 5 programming language for SIMATIC S5 programmable controllers.

Order No.: ISBN 3-528-04464-0

- **Automating with the S5-115U**  
SIMATIC S5 programmable controllers

Hans Berger  
Siemens AG, Berlin and Munich 1987

Contents:

- STEP 5 programming language
- Program processing
- Integral program blocks
- Interfaces to the peripherals

Order No.: ISBN 3-8009-1484-0

## Conventions

In order to improve the readability of the manual, a menu-style breakdown was used, i.e.:

- The individual chapters can be quickly located by means of a thumb register.
- There is an overview containing the headings of the individual chapters at the beginning of the manual.
- Each chapter is preceeded by a breakdown of its subject matter.  
The individual chapters are subdivided into sections and subsections. **Bold** face type is used for further subdivisions.
- Pages, figures and tables are numbered separately in each chapter. The page following the chapter breakdown contains a list of the figures and tables appearing in that particular chapter.

Certain conventions were observed when writing the manual. These are explained below.

- A number of abbreviations have been used.  
Example: Central processing unit (CPU)
- Cross-references are shown as follows:  
"( 7.3.2)" refers to subsection 7.3.2.  
No references are made to individual pages.

- Information of particular importance appears between two thick gray bars.

**Note:**

Additional information; highlighting a special feature or characteristic.

**CAUTION**

Information you must observe to avoid damage to the hardware or software.

**WARNING**

If this information is not observed, persons will be at risk.

Manuals can only describe the current version of the programmable controller. Should modifications or supplements become necessary in the course of time, a supplement will be prepared and included in the manual the next time it is revised. The relevant version or edition of the manual appears on the cover. In the event of a revision, the edition number will be incremented by "1".



**1**

## **System Overview**

**1.1**

**Block Diagram of the IP 267 Stepper Motor Controller . 1 - 2**

**1**

**Figures**

1-1.	Block Diagram of the IP 267	1	-	2
1-2.	Installing the IP 267 in the Bus Module	1	-	3

# 1 System Overview

As an intelligent input/output module, the IP 267 adds positioning to the repertoire of the S5-100U programmable controller. The IP 267 controls positioning processes independent of the execution times of the user programs in the programmable controller and the CPU is not loaded by current positioning jobs.

You can plug the IP 267 into slots 0 to 7 of the S5-100U where it occupies addresses in the analog address area of the programmable controller (bytes 64 to 127). The IP 267 runs with all CPUs except the CPU 100 (6ES5 100-8MA01).

The IP 267 has the following performance characteristics:

- Serial interface to the S5-100U programmable controller
- Digital inputs for calibrating and limiting traversing ranges
- Status displays for various operating states
- Programmable pulse generator
- Interfaces for commercial stepper motor power sections with 5 V differential inputs or other logic inputs in the range of 5 V to 30 V.



### 1.1 Block Diagram of the IP 267 Stepper Motor Controller

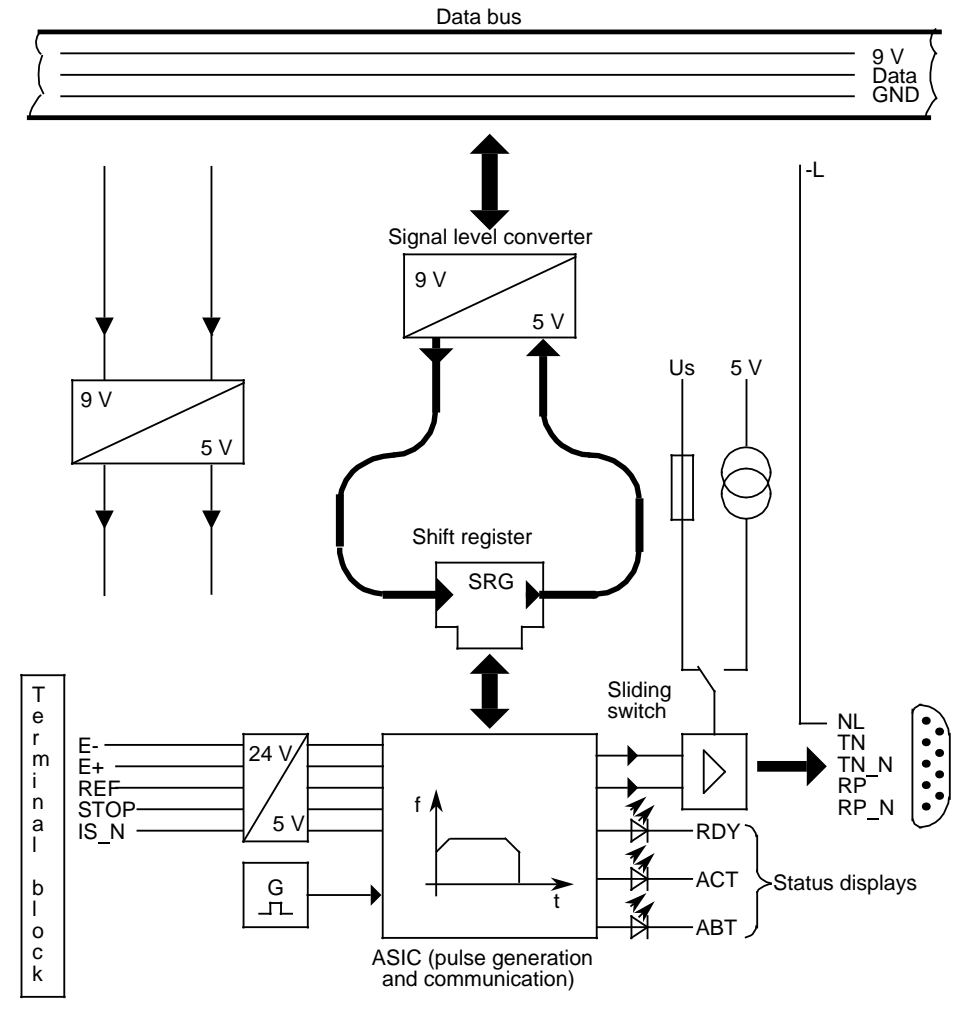

**Figure 1-1. Block Diagram of the IP 267**

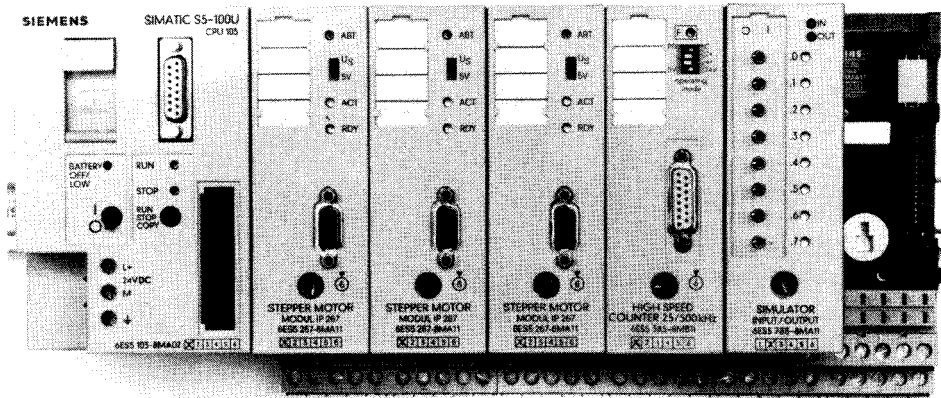

Figure 1-2. installing the IP 267 in the Bus Module

## **2 Driving Stepper Motors with the IP 267**

<b>2.1</b>	<b>Principle of Operation of the IP 267</b>	<b>2</b>	<b>-</b>	<b>1</b>
<b>2.2</b>	<b>Configuration Message Frame</b>	<b>2</b>	<b>-</b>	<b>2</b>
2.2.1	Limit Switch Configuration	2	-	3
2.2.2	Base Value for Frequencies (BV)	2	-	3
2.2.3	Start/Stop Rate	2	-	3
2.2.4	Time Interval for Stepping Rate Increase and Rate Decrease (TI)	2	-	4
<b>2.3</b>	<b>Full-Step or Half-Step Mode</b>	<b>2</b>	<b>-</b>	<b>5</b>

**Figures**

2-1.	Velocity Profile of the IP 267	.....	2	-	2
------	--------------------------------	-------	---	---	---

## 2 Driving Stepper Motors with the IP 267

To aid your understanding of the following chapters, this chapter deals with some fundamental terms and with the principle of operation of the stepper motor controller.

### 2.1 Principle of Operation of the IP 267

The IP 267 generates pulses for the stepper motor power section. The number of output pulses determines the length of the traversing path and the pulse frequency is a measure of the velocity. Each pulse causes the stepper motor shaft to turn through a certain angle. In the case of high-speed pulse trains, this step movement becomes a constant rotational movement. Stepper motors can reproduce all movement sequences exactly as long as no steps are lost. Step losses can be caused when load variations occur or when the programmed pulse trains exceed motor-specific values ( 5.6).

**2**

To enable the IP 267 to generate these pulse trains, the user must enter the following data:

- Configuration data; this data describes the individual traverse jobs and the technical characteristics of the drive system ( 4.1).
- Positioning data; you describe the individual traverse jobs and indicate the velocities, directions and lengths of the configured paths ( 4.2).

The IP exchanges data with the programmable controller via the serial interface ( Figure 1-1.). During the program scans, all necessary information is sent from the process output image (PIQ) to the IP 267 in 4-byte long message frames. The IP 267 cyclically transmits feedback signals on the distance to go and various status bits to the process input image (PII). See 4.1 to 4.3 for more details.



Using the configuration and positioning data settings, the IP 267 generates a symmetrical traverse profile consisting of an acceleration ramp, a constant velocity range and a deceleration ramp.

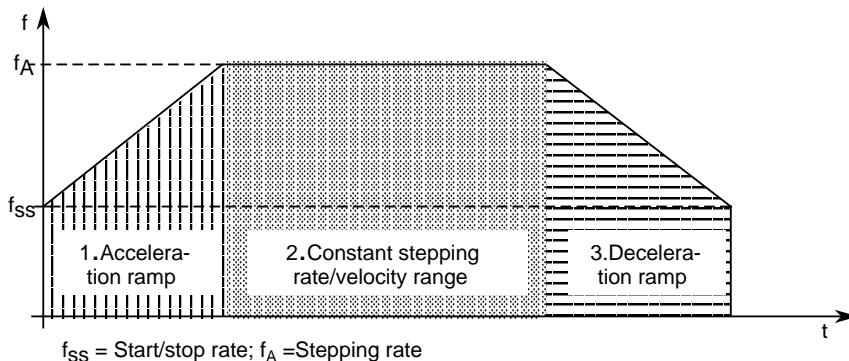

**Figure 2-1. Velocity Profile of the IP 267**

## 2.2 Configuration Message Frame

The configuration message frame data must be sent to the module at startup, after every interruption in the power supply and following response of the emergency limit switch (PD). The module can only accept positioning data if the signals of the emergency limit switch (PD) are present and if they have been configured. The module signals this status with the green "RDY" LED on its frontplate: "RDY" lights up if the IP 267 can accept positioning jobs. See Chapter 6.1 for a programming example for configuration.

The following are details of the information each configuration message frame must contain:

- End switch configuration
- Base value for the stepping rate
- Start/stop rate
- Time interval for stepping rate increase and decrease

The meaning of this information is described in the following pages.

## 2.2.1 Limit Switch Configuration

The IP 267 can monitor the end points of the traversing range and interrupt traverse movements if the permissible range is exceeded. You must connect limit switches to the digital inputs I+ and I- for this purpose. You can use both NC and NO switches here. You can determine the desired signal behaviour with the limit switch configuration ("0" active for NCs or "1" active for NOs.). See Chapter 4.1.3 for further details on this point .

## 2.2.2 Base Value for Frequencies (BV)

You can select frequency ranges by setting a base value for the start/stop rate and for the stepping rate  $f_A$ . The base value multiplied by the SS value (multiplier for  $f_{SS}$  ) gives the start/stop rate: if you multiply BV with V (multiplier for  $f_A$ ) you get the stepping rate  $f_A$  ( 4.1.5). The duration of the output pulses is determined by the frequency range set ( Table 4-4.).

Frequency range: 0.4 Hz to 204 kHz

Relevant pulse duration: 255  $\mu$ s to 1  $\mu$ s

## 2.2.3 Start/Stop Rate

Stepper motors can be driven by the IP 267 from standstill with the start/stop rate  $f_{SS}$  without losing steps or coming to a standstill. The value for  $f_{SS}$  must be found specially for each plant ( 6.6.3). During the deceleration phase, the frequency is continuously reduced from the stepping rate  $f_A$  to the start/stop rate  $f_{SS}$ . The IP 267 cannot generate control pulses lower than the start/stop rate ( Figure 2-1.).

You can set a value between 1 and 255 with bits SS 0 to SS 7. If you multiply this value with the base value (BV) for the stepping rates, you get the start/stop rate.

The following formula applies:

$$f_{ss} \text{ (Hz)} = BV \text{ (Hz)} \cdot SS \cdot R$$

$f_{ss}$  = Start/stop rate

BV = Base value for the frequency

SS = Multiplier for the start/stop rate

R = Reduction factor (1 oder 0.1) for the start/stop rate ( $f_{ss}$ ) and the stepping rate ( $f_A$ )

The reduction factor R is transferred with the positioning job.

Starting from the start/stop rate  $f_{ss}$ , the frequency is incremented by a certain amount after each time interval (TI), until the preset stepping rate is reached. The absolute value for the frequency increase in the stepping rate is linked to the preset base value (BV) for the frequencies.

The number of the pulses output in the acceleration range is acquired by an internal counter and used as a position setting for the deceleration range. The stepping rate is modified by the same amount in the deceleration range as in the acceleration range. This generates a symmetrical velocity profile with equal acceleration and deceleration curves ( Figure 2-1.). This profile is also maintained when the traversing motion is interrupted, e.g. by limit switches (I+, I -), the STOP switch or reference point switch. Only by the emergency limit switch (PD) is a traversing motion immediately interrupted, i.e. without deceleration ramp ( 3.4).

## 2.2.4 Time Interval for Stepping Rate Increase and Rate Decrease (TI)

Starting from the start/stop rate, the acceleration rate is incremented by a quarter of the base value (BV) after each time interval (TI), until the stepping rate is reached. In the deceleration range, the frequency is reduced by the same amount after each time interval. You can determine the time interval TI with bits TI 0 to TI 7 and the value set is multiplied by a basic time of 32  $\mu$ s ( 4.1.4).

### **2.3 Full-Step or Half-Step Mode**

Most power sections can operate stepper motors in half-step mode or in full-step mode. The dynamic torque of a stepper motor increases in half-step mode, but the motor requires double the number of pulses per revolution since the step angle is halved. Path resolution doubles in the case of half-step mode, thus achieving higher positioning accuracy. The acceleration value and the maximum traversing velocity are reduced by half compared to full-step mode.

You can set full-step or half-step mode on almost all stepper motor power sections using DIP switches, etc. You do not have to change anything on the stepper motor itself. However, please follow the relevant power section manufacturer's instructions.

## **3 Module Description**

<b>3.1</b>	<b>General Technical Specifications . . . . .</b>	<b>3 - 1</b>
<b>3.2</b>	<b>Power Supply . . . . .</b>	<b>3 - 2</b>
<b>3.3</b>	<b>Terminal Block Connector Pin Assignments . . . . .</b>	<b>3 - 3</b>
<b>3.4</b>	<b>Technical Specifications of the Digital Inputs . . . . .</b>	<b>3 - 4</b>
<b>3.5</b>	<b>Technical Specifications of the Drive Circuit . . . . .</b>	<b>3 - 6</b>
<b>3.6</b>	<b>Status Displays . . . . .</b>	<b>3 - 8</b>
<b>3.7</b>	<b>Connecting Cables for Power Sections . . . . .</b>	<b>3 - 9</b>

<b>Figures</b>			
3-1.	Terminal Block Assignment Schematic	3 -	3
3-2.	Schematic of the Drive Circuit	3 -	6
3-3.	9-Way Subminiature D Female Connector for Connecting the Stepper Motor Power Sections (Terminal End)	3 -	7
3-4.	Frontplate of the IP 267	3 -	8
<b>Tables</b>			
3-1.	General Technical Specifications (Part 1)	3 -	1
3-2.	General Technical Specifications (Part 2)	3 -	2
3-3.	IP 267 Terminal Block Connector Pin Assignments	3 -	3
3-4.	Digital Inputs	3 -	5
3-5.	Connector Pin Assignments Between the IP 267 Connecting Cable and the Power Section	3 -	9

## 3 Module Description

This chapter will give you an overview of the technical specifications of the IP 267, the power supply, terminal assignments of the terminal block, input and output signals, status displays on the frontplate and a list of the connecting cables for the power sections.

### 3.1 General Technical Specifications

**Table 3-1. General Technical Specifications (Part 1)**

Climatic Environmental Conditions		Mechanical Environmental Conditions	
<b>Temperature</b> Operation - Horizontal arrangement    0 to +60° C - Vertical arrangement        0 to +40° C (Intake air temperature measured at the bottom of the modules)  Storage/shipping                -40° C to +70° C  Temperature change - Operation                        max. 10° C / h - Storage/shipping                max. 20° C / h  Relative humidity                to DIN 40040 15 ... 95% (indoor) Noncondensing  Atmospheric pressure - Operation                        860 to 1060 hPa - Storage/shipping                660 to 1060 hPa		Vibration - tested with  to IEC 68-2-6 10 to 57 Hz, (constant amplitude 0.15 mm/0.006 in. )  57 to 500 Hz, (constant acceleration 2 g)  Shock - tested with  to IEC 68-2-27 12 shocks (semisinusoidal 15 g / 11 ms)  Free-fall - tested with  to IEC 68-2-32 Height of fall 1 m/3.3ft.	

**Table 3-2. General Technical Data (Part 2)**

Electromagnetic Compatibility (EMC) Noise Immunity	Specifications on IEC/VDE Safety
<b>Damped oscillatory wave test (1 MHz)</b> to IEC 255-4  Digital input/output modules 1 kV	Degree of protection IP 20 to IEC 529  - class I to IEC 536
<b>Radiated electromagnetic field test</b> to IEC 801-3 Field intensity 3 V / m  <b>Fast transient burst test</b> to IEC 801-4	Insulation rating - Between electrically independent circuits and - circuits connected to a central ground point to VDE 0160
Digital input/output modules 1 kV  <b>Static electricity test</b> to IEC 801-2 Discharge onto all parts accessible to the user in normal operation 3 kV	Test voltage Sinusoidal 50 Hz for a rated voltage $V_e$ of the AC or DC circuits of $V_e=0$ to 50 V 500 V

### 3.2 Power Supply

Supply voltage from the bus  
Current consumption

9 V  
approx. 150 mA

Special voltage  $V_s$

5 V to 30 V



### 3.3 Terminal Block Connector Pin Assignments

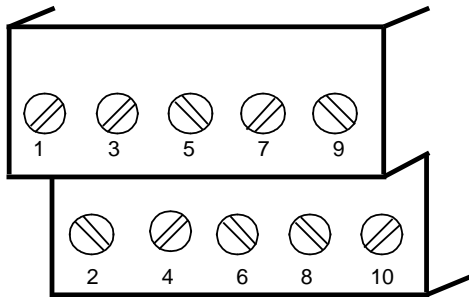

Figure 3-1. Terminal Block Assignment Schematic

**CAUTION:**

Always connect the zero voltage reference for NL (pin 2 of the terminal block) to the ground of the PC. Only this will guarantee problem-free operation of the module.

3

Table 3-3. IP 267 Terminal Block Connector Pin Assignments

Pin	Meaning	
1	---	
2	NL	Reference potential to $V_S$ and the digital inputs
3	EPLUS	Digital input for limit switch I+
4	EMINUS	Digital input for limit switch I -
5	REF	Digital input for reference switch
6	STOP	Digital input for external stop
7	IS	Digital input for emergency limit switch (pulse inhibit)
8	---	
9	$V_S$	Special voltage $V_S$ (input)
10	---	

### 3.4 Technical Specifications of the Digital Inputs

The IP 267 can calibrate and limit the traversing range via five digital inputs (24 V). Limit switches for initiating deceleration can be connected to the inputs I - and I +. You can set the method of signal evaluation ("0"-active or "1"-active) when configuring the module. The STOP input terminates the traversing movement and also initiates deceleration; it always has the same signal evaluation as inputs I - and I+. Reference switches (BEROs, etc.) can be connected to the REF input. The PD input is for connecting emergency limit switches and the input is always "0"-active (NC). Pulse output is inhibited immediately when the emergency limit switch (PD) responds. The red "ABT" LED on the frontplate of the IP 267 lights up. You must proceed as follows if the IP is to accept new positioning jobs:

- The emergency limit switch must be enabled again.
- The configuration data on the IP 267 must be deleted, causing the "ABT" and "RDY" LEDs to go out.
- The configuration data must be transferred back to the IP 267. The green "RDY" LED lights up when the module is configured.

**Note:**

The IP 267 is disabled when the emergency limit switch responds and it can only accept new positioning jobs if you delete the old configuration data and then reconfigure the module.







### 3.6 Status Displays

After you have switched on the power supply and connected the emergency limit switch (PD), you must transfer the user-specific configuration data (frequency range, start/stop rate, time interval for acceleration and deceleration, operating mode, selector signal for limit switch configuration) to the IP 267. The module can only accept positioning jobs when it has received a valid configuration message frame. This is indicated by the green "RDY" LED on the frontplate ( Figure 3-4.) and in the status bit of the feedback message frame. Another green "ACT" LED signals pulse output in the case of a positioning job. The red "ABT" LED lights up when positioning jobs have been interrupted e.g by the emergency limit switch (PD).

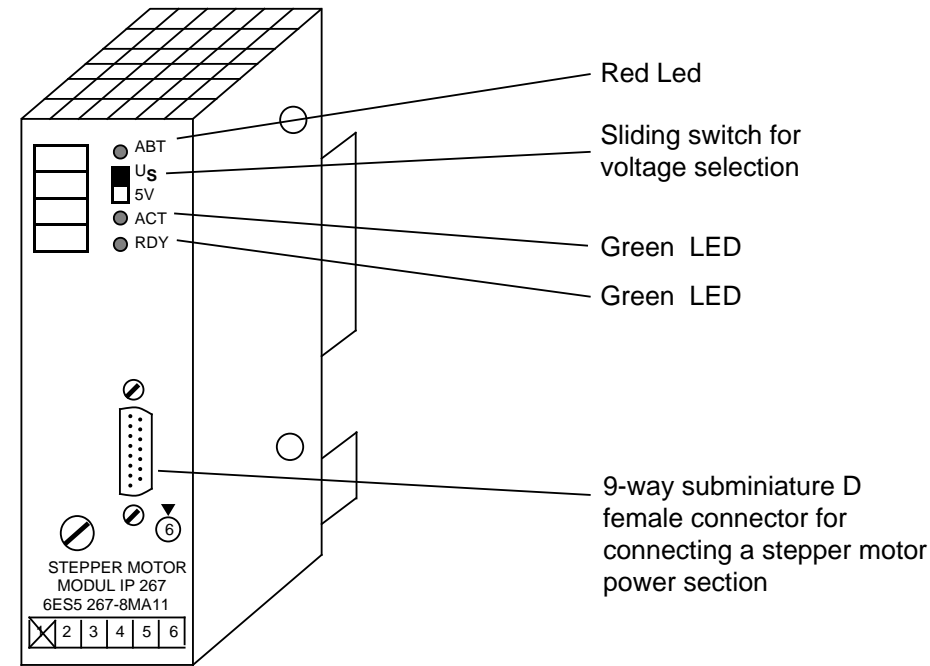

**Figure 3-4. Frontplate of the IP 267**

### 3.7 Connecting Cables for Power Sections

To make the connection of power sections easier, there are connecting cables with open cable ends available for the user.

5 m long: Order No.: 6ES5 736-6BF00  
 10 m long: Order No.: 6ES5 736-6CB00  
 16 m long: Order No.: 6ES5 736-6CB60  
 ( Catalog ST 52.3)

**Table 3-5. Connector Pin Assignments Between the IP 267 Connecting Cable and the Power Section**

Pin	Core colour	Meaning	
2	White	TN	Clock
4	Brown	TN_N	Clock inverted
7	Green	RP	Direction level
8	Yellow	RP_N	Direction level inverted
9	Grey	NL	Ground

The cable shielding is connected to the connector shell.

#### IP 267 connector set (6ES5 750-2AA11)

There is a connector set for connecting power sections available for those users who do not favor prefabricated cable assemblies. This set consists of a pin connector insert (for soldered connection), the upper and lower shell sections with assembled shields, cable clamps and screws.

## 4 Addressing and Programming

<b>4.1</b>	<b>Configuring the IP 267</b> .....	<b>4</b>	<b>-</b>	<b>3</b>
4.1.1	Address Assignment of the Configuration Message Frames (PC to IP) .....	4	-	4
4.1.2	Byte 0: Multiplier for the Start/Stop Rate (SS) .....	4	-	5
4.1.3	Byte 1: Limit Switch Configuration (LSC) and Operating Modes .....	4	-	5
4.1.4	Byte 2: Time Interval (TI) for Rate Increase/Decrease ...	4	-	5
4.1.5	Byte 3: Base Value for the Frequencies (BV) .....	4	-	6
4.1.6	Deleting the Configuration .....	4	-	7
<b>4.2</b>	<b>Positioning Message Frames (PC to IP)</b> .....	<b>4</b>	<b>-</b>	<b>8</b>
4.2.1	Address Assignment of the Positioning Message Frames .....	4	-	9
4.2.2	Byte 0: Multiplier for the Velocity (V) .....	4	-	10
4.2.3	Byte 1: Path/Operating Mode .....	4	-	11
4.2.4	Byte 2: Path .....	4	-	14
4.2.5	Byte 3: Path .....	4	-	14
<b>4.3</b>	<b>Feedback Message Frames (IP 267 to PC)</b> .....	<b>4</b>	<b>-</b>	<b>15</b>
4.3.1	Address Assignment of the Feedback Message Frames .	4	-	16
4.3.2	Byte 0: Status Bits .....	4	-	17
4.3.3	Byte 1: Status Bits and Distance to Go .....	4	-	18
4.3.4	Byte 2: Distance to Go .....	4	-	20
4.3.5	Byte 3: Distance to Go .....	4	-	20
<b>4.4</b>	<b>Combining the Message Frame Assignments and the Most Important Formulas</b> .....	<b>4</b>	<b>-</b>	<b>21</b>



<b>Figures</b>		
4-1.	Velocity Profile of the IP 267	4 - 2
4-2.	Operating Modes Diagram	4 - 14
4-3.	Flowchart for Job Monitoring with the "IJE" Bit	4 - 19
<b>Tables</b>		
4-1.	Address Assignment of the Modules	4 - 1
4-2.	Addressing the Configuration Message Frames	4 - 3
4-3.	Address Assignment of the Configuration Message Frames	4 - 4
4-4.	Selecting the Frequency Range	4 - 6
4-5.	Addressing the Positioning Message Frames	4 - 8
4-6.	Address Assignment of the Positioning Message Frames	4 - 9
4-7.	Operating Mode Bits	4 - 11
4-8.	Addressing Feedback Message Frames	4 - 15
4-9.	Address Assignment of the Feedback Message Frames	4 - 16
4-10.	Address Assignment of the Configuration Message Frames (PC to IP 267)	4 - 21
4-11.	Address Assignment of the Positioning Message Frames (PC to IP 267)	4 - 20
4-12.	Address Assignment of the Feedback Message Frames (PC to IP 267)	4 - 22
4-13.	Frequency Ranges	4 - 23

## 4 Addressing and Programming

The IP 267 can be plugged into slots 0 to 7 of the S5-100U programmable controller. There are eight bytes reserved for each slot in both the process input image (PII) and the process output image (PIQ) and data exchange is via the first four bytes of the PII and the PIQ. The last four bytes of the PII and the PIQ remain free but they cannot be reserved for other uses. The IP 267 is accessed via the process I/O images (PII, PIQ) with the same input addresses and output addresses (address overlap).

**Table 4-1. Address Assignment of the Modules**

PS	CPU	Slots									
		0	1	2	3	4	5	6	7	8	9
Analog addresses		64 to 71	72 to 79	80 to 87	88 to 95	96 to 103	104 to 111	112 to 119	120 to 127	Not permissible from slot 8 onward	

4

The permissible address area ranges from 64 to 127. The IP 267 is accessed with byte or word load and transfer operations just like analog input/output modules.

**Example:** Data exchange between the CPU and the IP 267 (on slot 3)

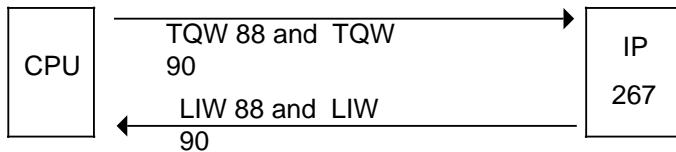

The IP 267 exchanges data with the CPU of the programmable controller via the serial interface. The user writes configuration data and positioning jobs into the process output image (PIQ). From there this data is transferred once in every data cycle to the IP 267. A disable in the IP 267 prevents the same jobs being executed repeatedly.

The IP 267 generates symmetrical velocity profiles from the configuration and positioning data. These profiles have equal acceleration and deceleration ramps ( Figure 4-1.).

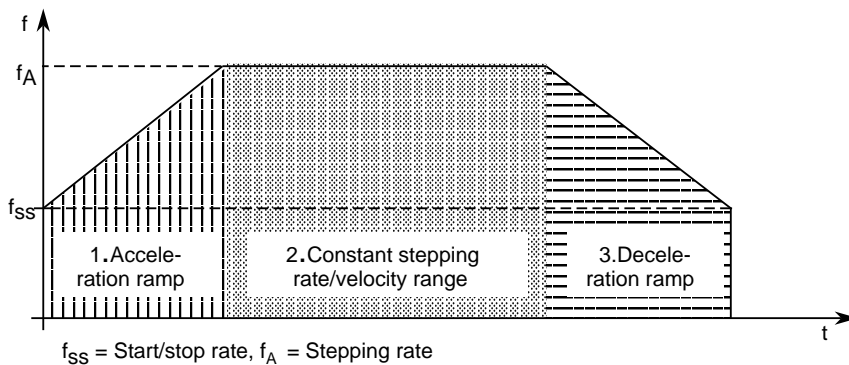

**Figure 4-1. Velocity Profile of the IP 267**

Data from the IP 267 (feedback messages, distance to go, status) is stored in the process input image (PII) cyclically and can be transferred cyclically from there to the user program.

## 4.1 Configuring the IP 267

The IP 267 must always be configured after commissioning or after deleting valid configuration data. The data is transferred to the IP 267 only after applying the emergency limit switches (PDs). The first data set transferred from the PC to the IP is interpreted as the configuration message frame, provided the multiplier for the start/stop rate is not zero and the configuration bits are reset (KB0=0 and KB1=0).

**Note:**

The CPU cannot read the currently valid configuration data direct from the IP 267. It is therefore advisable to store the configuration data additionally in two flag words or in a data block on the CPU when you configure the module. You can then access this data at any time.

**Table 4-2. Addressing the Configuration Message Frames**

Slot No.	BYTE			
	0	1	2	3
0	QB64	QB65	QB66	QB67
1	72	73	74	75
2	80	81	82	83
3	88	89	90	91
4	96	97	98	99
5	104	105	106	107
6	112	113	114	115
7	120	121	122	123

4

### 4.1.1 Address Assignment of the Configuration Message Frames (PC to IP)

**Table 4-3. Address Assignment of the Configuration Message Frames**

<b>Byte 0</b>	7 6 5 4 3 2 1 0	} Multiplier for the start/stop rate 1 SS 255
<b>Byte 1</b>	7 6 5 4 3 2 1 0	} Unassigned KB1 Configuration bits KB0 } Unassigned LSC Limit switch configuration Unassigned
<b>Byte 2</b>	7 6 5 4 3 2 1 0	} Time interval (TI) for stepping rate increase/decrease 1 TI 255
<b>Byte 3</b>	7 6 5 4 3 2 1 0	} Unassigned FB2 Base value for FB1 the rates FB0

### 4.1.2 Byte 0: Multiplier for the Start/Stop Rate (SS)

Bit 0 to 7: The process output image (PIQ) has "0" default after resetting. You must enter a value between 1 and 255 in byte 0, otherwise the configuration message frame will be ignored.

$$f_{ss} \text{ (Hz)} = \text{BV(Hz)} * \text{SS} * \text{R}$$

- $f_{ss}$  = Start/stop rate
- BV = Base value for the rate ( Table 4-4.)
- SS = Multiplier for the start/stop rate (1 to 255)
- R = Reduction factor (1 or 0.1). This factor is determined during the current positioning job.

### 4.1.3 Byte 1: Limit Switch Configuration (LSC) and Operating Modes

- Bit 1= 0: Inputs I+, I- (external STOP) "0"-active (NC)
- Bit 1= 1: Inputs I+, I- (external STOP) "1"-active (NO)



Bit 4 to 5: Both configuration bits KB0 and KB1 must be "0" for the configuration message frame to be accepted. This is always the case during startup or when switching on the power.

### 4.1.4 Byte 2: Time Interval (TI) for Rate Increase/Decrease

You determine the values for TI with bits TI 0 to TI 7. During the acceleration phase, the rate is incremented from the start/stop rate  $f_{ss}$ . It is incremented in each time interval by a quarter of the base value (BV) until the stepping rate  $f_A$  is reached. The stepping rate is decremented in the same way in the deceleration phase.

Bit 0 to 7: You must enter a value for the multiplier TI between 1 and 255 in byte 2 of the configuration message frame. The value "0" disables pulse generation. During cold restart or on power up, the value "0" for TI is entered in the PIQ.

$$a \text{ (Hz/ms)} = \frac{\text{BV (Hz)} * R}{4 * 0.032 \text{ ms} * \text{TI}}$$

- a = Frequency increase or decrease
- BV = Base value for the frequency ( Table 4-4.)
- TI = Multiplier for the time interval TI (1 to 255)
- R = Reduction factor (1 or 0.1). This factor is determined in the current positioning job.

#### 4.1.5 Byte 3: Base Value for the Frequencies (BV)

Bit 0 to 2: You can select the eight possible frequency ranges for BV with the three bits FB 0 to FB 2. If you do not enter a value, the module has a default value of BV = 800 Hz on cold restart or on power up.

**Table 4-4. Selecting the Frequency Range**

FB2	FB1	FB0	Base value (Hz)	Accel./decel. (Hz/ms) TI = 1 to 255	Max. freq. in kHz where V = 255	Pulse duration $\mu$ s)
0	0	0	800	6250 to 24.5	204	2
0	0	1	400	3125 to 12.25	102	3
0	1	0	200	1560 to 6.12	51	7
0	1	1	80	625 to 2.45	20.4	15
1	0	0	40	312 to 1.22	10.2	31
1	0	1	20	156 to 0.61	5.1	63
1	1	0	8	62.5 to 0.25	2.04	127
1	1	1	4	31.2 to 0.12	1.02	255

The values for frequency and acceleration/deceleration in Table 4-4. only apply if you set reduction factor 1 in the positioning job (bit R="0"). Divide the values given by 10 (bit R="1") for reduction factor 0.1. The pulse duration is not affected by this.

#### **4.1.6 Deleting the Configuration**

An existing IP 267 configuration can be deleted by sending a new job with the velocity 0 and operating mode "STOP" to the IP 267 following transmission of a positioning job (Bit IQA = 0). The module then switches over to the "Non-configured" state; the LEDs on the front darken. The IP needs to be reconfigured before it can process any positioning jobs.



## 4.2 Positioning Message Frames (PC to IP)

You must transfer the configuration data to the IP 267 ( 4.1) before you send positioning jobs. When the IP has been configured, the green "RDY" LED on the frontplate lights up and the status bit ILCN in the feedback message frame is reset ( 4.3.2).

A positioning job consists of the path definition (number of pulses to be executed), the multiplier for the velocity, the reduction factor for the velocity, the operating mode (forwards, backwards etc.) and an identifier bit for the reference point approach ( 5.4).

**Table 4-5. Addressing the Positioning Message Frames**

Slot No.	BYTE			
	0	1	2	3
0	QB 64	QB 65	QB 66	QB 67
1	72	73	74	75
2	80	81	82	83
3	88	89	90	91
4	96	97	98	99
5	104	105	106	107
6	112	113	114	115
7	120	121	122	123

### 4.2.1 Address Assignment of the Positioning Message Frames

**Table 4-6. Address Assignment of the Positioning Message Frames**

<b>Byte 0</b>	7 6 5 4 3 2 1 0	<p>} Multiplier for the velocity 1 V 255</p>
<b>Byte 1</b>	7 6 5 4 3 2 1 0	<p>Reduction factor R (1 or 0.1) Reference point approach RPA OM0    Operating modes OM1 <math>2^{19}</math> <math>2^{18}</math>    Step pulses for the path (binary coded) <math>2^{17}</math> <math>2^{16}</math></p>
<b>Byte 2</b>	7 6 5 4 3 2 1 0	<p><math>2^{15}</math> } <math>2^{14}</math> } <math>2^{13}</math> } <math>2^{12}</math> }    Step pulses for the path (binary coded) <math>2^{11}</math> } <math>2^{10}</math> } <math>2^9</math> } <math>2^8</math> }</p>
<b>Byte 3</b>	7 6 5 4 3 2 1 0	<p><math>2^7</math> } <math>2^6</math> } <math>2^5</math> } <math>2^4</math> }    Step pulses for the path (binary coded) <math>2^3</math> } <math>2^2</math> } <math>2^1</math> } <math>2^0</math> }</p>

## 4.2.2 Byte 0: Multiplier for the Velocity (V)

Bit 0 to 7: You must enter a binary value between 1 and 255 in byte 0. You can calculate the stepping rate according to the following formula:

$$f_A \text{ (Hz)} = BV(\text{Hz}) * V * R$$

- $f_A$  = Stepping rate of the motor
- $BV$  = Base value for the frequency ( Table 4-4.)
- $V$  = Multiplier for the velocity (1 to 255)
- $R$  = Reduction factor (1 or 0.1). The factor is determined in the current positioning job

### Note:

You can enter values from 1 to 255 for the multiplier. The maximum stepping rate with a base value of  $BV = 800$  Hz is then 204 kHz. The IP 267 cannot generate stepping rates lower than the preset start/stop rate ( $f_{ss}$ ). Lower stepping rates are corrected to the value of  $f_{ss}$ .

### 4.2.3 Byte 1: Path / Operating Mode

The path is specified as the number of step pulses to be executed. Bits P16 to P19 are the higher-order bits of the 20 bit address. The path can consist of a maximum of 1,048,575 pulses per job.

Bit 0 to 3: Path P 16 to P 19

Bit 4 to 5: Operating mode bits OM 0 and OM 1:

The IP 267 offers four basic operating modes each of which can be selected via the two operating mode bits OM0 and OM1 in the positioning job or during configuration ( Table 4-7.).

**Table 4-7. Operating Mode Bits**

OM 1	OM 0	Meaning
0	0	Stop
0	1	Start forwards
1	0	Start backwards
1	1	Neutral (preparation for a new job)

4

#### "STOP" mode

Message frames with the "STOP" mode are interpreted as follows by the IP 267:

1. "STOP" in conjunction with velocity = 0:  
Interruption of current positioning jobs (with deceleration ramp)
2. "STOP" in conjunction with velocity = 0:  
Delete module configuration
3. "STOP" in conjunction with start/stop rate ( $f_{ss}$ ) = 0:  
Reconfigure module, e.g. after power failure

You can abort positioning jobs by sending the "STOP" mode to the IP. Pulse output is not interrupted abruptly in this case but terminated with a deceleration ramp ( Figure 2-1.)

The module is in a "non-configured" state after power failure since all data in the IP is deleted. The first message frame sent by the programmable controller to the IP 267 is interpreted as the configuration message if both operating mode bits signify "STOP" status and if the start/stop rate is not zero. Otherwise the data set is not accepted and the module remains in the "non-configured" state. Valid configuration data can be deleted if the "STOP" mode is sent to the IP in conjunction with the velocity setting zero. In this case, the "Module configured" LED (RDY) goes out.

### **"Start forwards" mode**

The IP 267 can only execute a "Start forwards" job if it is in the "Standstill" state and has previously executed one of the other operating modes ("Start backwards", "STOP" or "Neutral"); otherwise the module ignores the job. In the case of "Start forwards", the IP 267 sets the RP (direction level) output to logic "1" and the RP\_N (inverted direction level) output to logic "0".

### **"Start backwards" mode**

In the case of jobs with the "Start backwards" mode, the levels at outputs RP and RP\_N are exchanged (RP = "0", RP\_N = "1").

The IP 267 does not accept "Start forwards" or "Start backwards" positioning jobs with the path set to 0.

### **"Neutral" mode (preparation for a new job)**

The process output image PIQ is output to the modules connected each time the programmable controller program is scanned. A positioning job can therefore be sent to the IP 267 on several occasions but the IP only executes the first job. The IP will only execute a subsequent job if it receives a different operating mode to the previous one.

If you allocate two traversing jobs with the same direction, you must remove the disable after the start of the first job by transferring "Neutral" mode to the module. However, you should first scan the status message "Job executing" (IJE) to determine that the first job has been executed. If IJE = 0, you can start a new job in the same direction. Subsequent jobs with a different direction to the previous job can be started without first activating the "STOP" or "Neutral" modes ( 6.2.1).

Bit 6:           Reference point approach RPA  
The reference point marks a system zero point for the IP 267 from which it starts traversing jobs. You can calculate reference points if you connect a separate switch (BERO, etc.) to the REF digital input. If you set bit RPA, a positive edge at the REF digital input initiates deceleration ( 5.4).

Bit 7:           Reduction factor R  
You can reduce the frequency range of the stepping rate and the start/stop rate by a factor of 10 using R. The pulse duration is unaffected by this.

R="0"       :    Reduction factor 1  
R="1"       :    Reduction factor 0.1



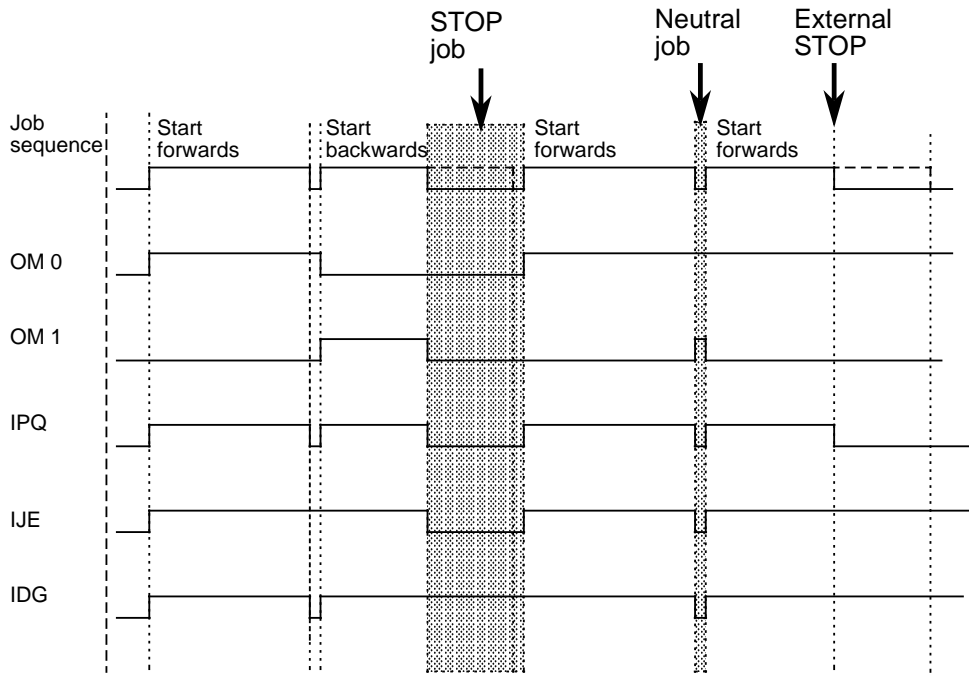

**Figure 4-2. Operating Modes Diagram**

Status bits of the feedback message frame (IP 267 to PC)

IPQ = Pulse output active

IJE = Job executing

IDG = Distance to go

See 4.3.2 for further information on the feedback message frame.

#### 4.2.4 Byte 2: Path

Bit 0 to 7: Paths P 8 to P 15

#### 4.2.5 Byte 3: Path

Bit 0 to 7: Paths P 0 to P 7

### 4.3 Feedback Message Frames (IP 267 to PC)

Information on the distance to go and the status bits of the IP 267 are sent in the feedback message frame to the addresses in the process input image (PII) ( Table 4-8.). The process I/O images (PII and PIQ) are updated after every scan of OB 1. The contents of the PIQ are transferred to the IP 267 at the same time as the feedback messages of the IP 267 are transferred to the PII. The feedback messages of the IP 267 are therefore always delayed by one OB cycle. The feedback message for a particular positioning job can therefore be evaluated after the next OB cycle.

The distance to go and the status bits are stored until the IP 267 receives a new positioning job or the configuration is deleted. Bits "IPQ" (pulse output), "IPD" (pulse disable), "ILCN" (configuration executed) and "IJE" (job executing) are exceptions to this. IPQ is only set for the duration of pulse output; "IPD" is set when the digital input PD (emergency limit switch) is active. You can only reset "IPD" when PD is no longer active (limit switch not activated) and the configuration of the module is deleted.

**Table 4-8. Addressing Feedback Message Frames**

Slot No.	BYTE			
	0	1	2	3
0	QB 64	QB 65	QB 66	QB 67
1	72	73	74	75
2	80	81	82	83
3	88	89	90	91
4	96	97	98	99
5	104	105	106	107
6	112	113	114	115
7	120	121	122	123





### 4.3.1 Address Assignment of the Feedback Message Frames

**Table 4-9. Address Assignment of the Feedback Message Frames**

<b>Byte 0</b>	7	IP 267 not configured	ILCN
	6	Pulse disable	IPD
	5	Pulse output	IPQ
	4	Distance to go	IDG
	3	Limit switch end	ILSE
	2	Limit switch start	ILSS
	1	Reference point	IRP
	0	External stop	IES
<b>Byte 1</b>	7	Distance to go < 0	DGS
	6	Job executing	IJE
	5	} Unassigned	
	4		
	3		
	2	} Step pulses of the distance to go (binary coded)	$2^{19}$
	1		$2^{18}$
	0		$2^{17}$
<b>Byte 2</b>	7	} Step pulses of the distance to go (binary coded)	$2^{15}$
	6		$2^{14}$
	5		$2^{13}$
	4		$2^{12}$
	3		$2^{11}$
	2		$2^{10}$
	1		$2^9$
	0		$2^8$
<b>Byte 3</b>	7	} Step pulses of the distance to go (binary coded)	$2^7$
	6		$2^6$
	5		$2^5$
	4		$2^4$
	3		$2^3$
	2		$2^2$
	1		$2^1$
	0		$2^0$

### 4.3.2 Byte 0: Status Bits

- Bit 0: External stop - "IES"  
The "IES" bit is set if the digital input STOP has been activated. The bit is reset by a new, valid job.
- Bit 1: Reference point - "IRP"  
The "IRP" bit is set if input REF has been activated during traversing movements with bit RPA set. The bit is reset by a new, valid job.
- Bit 2: Limit switch start - "ILSS"  
The "ILSS" bit is set if input I - has been activated during traversing movements with operating "Start backwards" mode. The bit is reset by a job with operating "Start forwards" mode even if the limit switch is still active.
- Bit 3: Limit switch end - "ILSE"  
The "ILSE" bit is set if input I+ has been activated during traversing movements with operating "Start forwards" mode. The bit is reset by a job with operating "Start backwards" mode even if the limit switch is still active.
- Bit 4: Distance to go - "IDG"  
The "IDG" bit is set if the IP 267 does not supply the specified number of pulses for a positioning job. The bit is reset after the complete number of pulses have been output.
- Bit 5: Pulse output - "IPQ"  
The "IPQ" bit is set as long as the module outputs step pulses. The bit is reset after the last pulse and the relevant pause has been output (period duration of the step frequency).

- Bit 6: Pulse disable - "IPD"  
The "IPD" bit is set if input PD is active. The IP 267 resets the "IPD" bit only when input PD is inactive and the module is reconfigured.
- Bit 7: IP 267 not configured - "ILCN"  
The "ILCN" bit is reset if valid configuration data is transferred to the module during the configuration run. The bit is set by a job with zero velocity and "STOP" mode.

### 4.3.3 Byte 1: Status Bits and Distance to Go

- Bit 0 to 3: Distance to go DV 16 to DV 19  
The distance to go indicates the number of (output) step pulses still to be executed. This number is stored in a 20-bit address as a binary value. P 16 to P 19 are the higher-order bits.
- Bit 4 to 5: Unassigned
- Bit 6: Job executing - "IJE"  
The "IJE" bit "Job executing" is set as soon as a "Start forwards" or "Start backwards" job is transferred to the IP 267 and executed. The "IJE" bit is reset if the operating mode changes to neutral or STOP and pulse output of the current job is complete (both conditions must be met). You can use "IJE" as an acknowledgement bit if you execute positioning jobs with extremely short paths: if the duration of pulse output is shorter than the PC scan time, you cannot use the status feedback message "IPQ" to check if a job has already been executed. By contrast, "IPQ" remains set even after pulse output ( Figure 4-2.).

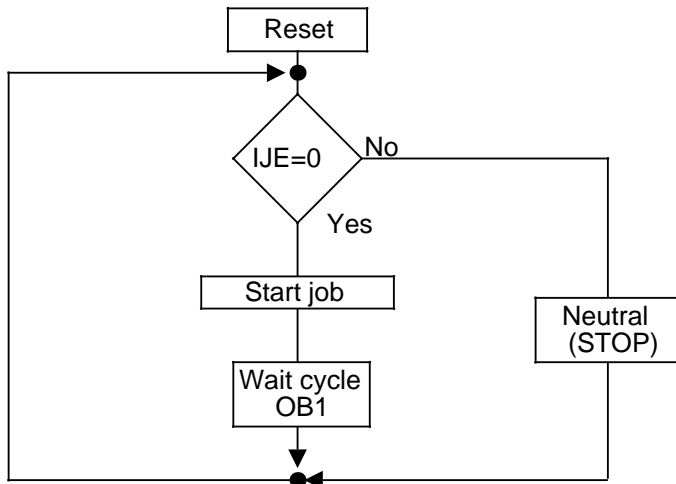

**Figure 4-3. Flowchart for Job Monitoring with the "IJE" Bit**

Bit 7: Sign of the distance to go DGS  
 "0"=positive  
 "1"=negative

4

The IP 267 can abort positioning jobs with external signals, e.g. with the limit switches EPLUS or EMINUS. After abort signals in the acceleration phase, the IP continues sending pulses for another 50 ms at the rate already reached. After expiration of these 50 ms, it will initiate the deceleration phase. This procedure avoids sudden rate changes which could result in step losses.

**Note:**

In the case of an abort in the acceleration phase, the IP 267 outputs more pulses than provided for under the following conditions:

- 33% to 37.5% of all pulses have already been output
- The velocity reached at job abort was so high that, during the period of 50 ms, the same number of pulses was output as during the acceleration phase.

Since exactly the same number of pulses are output in the deceleration phase as in the acceleration phase, the IP 267 outputs a maximum of 112.5% (3 x 37.5%) of the specified pulses. The distance to go has a negative sign in this case and the "DGS" bit is set. You can interrupt your program at this point, if necessary, and take suitable measures, e.g. start a reference point approach.

#### **4.3.4 Byte 2: Distance to Go**

Bit 0 to 7: Distance to go DV 8 to DV 15

#### **4.3.5 Byte 3: Distance to Go**

Bit 0 to 7: Distance to go DV 0 to DV 7

### 4.4 Combining the Message Frame Assignments and the Most Important Formulas

**Table 4-1. Address Assignment of the Configuration Message Frames (PC to IP 267)**

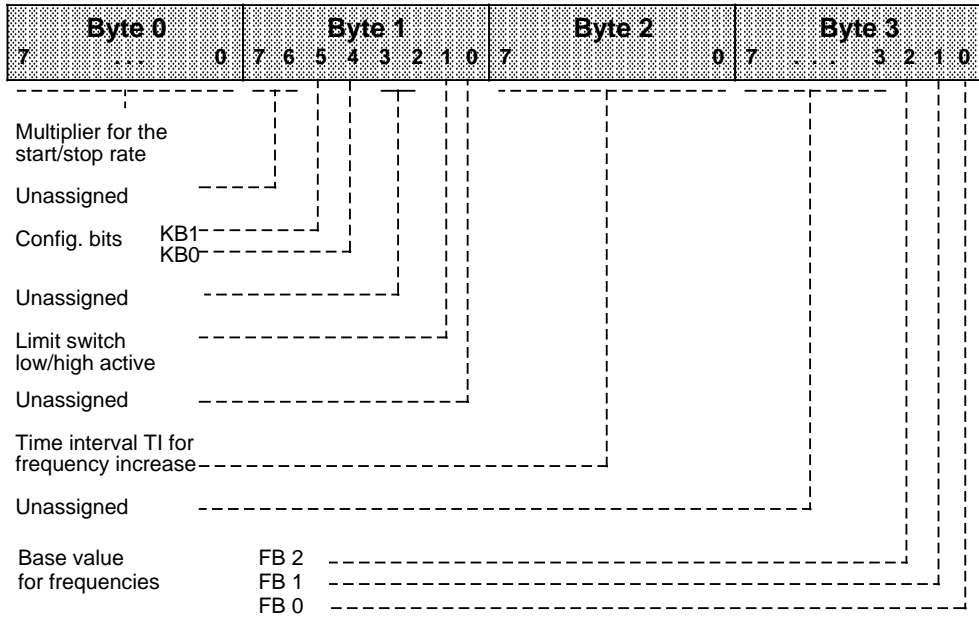

4

**Table 4-11. Address Assignment of the Positioning Message Frames (PC to IP 267)**

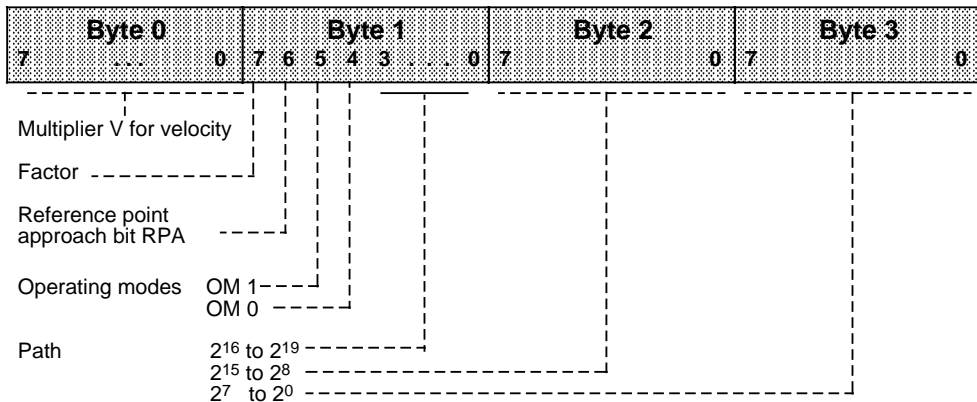

**Table 4-12. Address Assignment of the Feedback Message Frames (PC to IP 267)**

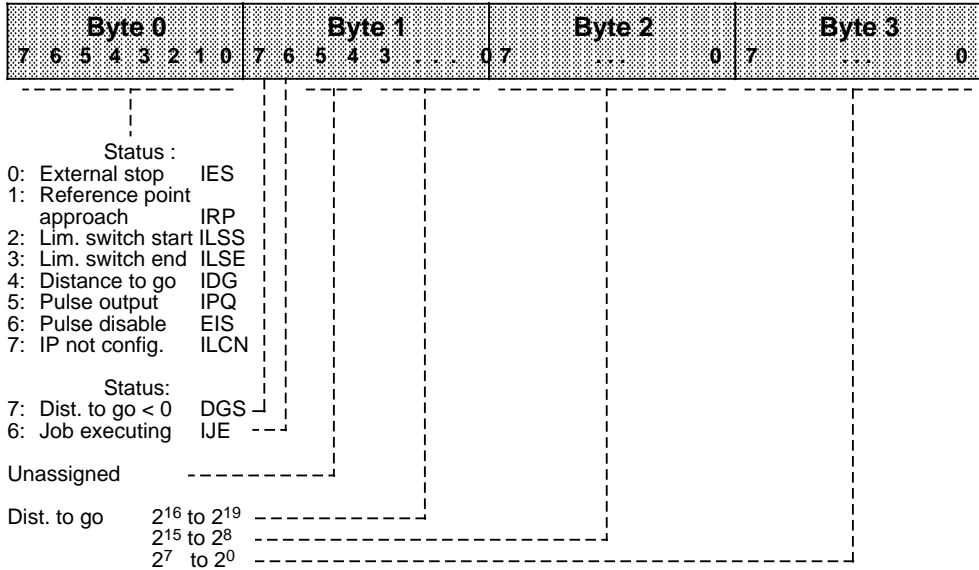

**Table 4-13. Frequency Ranges**

FB 2	FB 1	FB 0	Base value (Hz)	Accel./decel. (Hz/ms) TI=1 to 255	Max. freq. in kHz at V=255	Pulse duration (µs)
0	0	0	800	6250 to 24.50	204	2
0	0	1	400	3125 to 12.25	102	3
0	1	0	200	1560 to 6.12	51	7
0	1	1	80	625 to 2.45	20.40	15
1	0	0	40	312 to 1.22	10.20	31
1	0	1	20	156 to 0.61	5.10	63
1	1	0	8	62.5 to 0.25	2.04	127
1	1	1	4	31.2 to 0.12	1.02	255

4

**Formulas for frequency calculation and frequency modification:**

**Start/stop rate (f<sub>ss</sub>):**

$$f_{ss} \text{ (Hz)} = BV(\text{Hz}) * SS * R$$

**Frequency increase/decrease:**

$$a \text{ (Hz/ms)} = \frac{BV \text{ (Hz)} * R}{4 * 0.032 \text{ ms} * TI}$$

**Stepping rate (f<sub>A</sub>):**

$$f_A \text{ (Hz)} = BV(\text{Hz}) * V * R$$

SS= Multiplier for the start/stop rate (1 to 255)

TI = Multiplier for the time interval TI (1 to 255)

V= Multiplier for the velocity (1 to 255)

BV = Base value for frequencies  
 R = Reduction factor (1 or 0.1). This factor is determined in the current positioning job.



## **5 Notes on Operation**

<b>5.1</b>	<b>Safety Concept</b> .....	<b>5 -</b>	<b>1</b>
<b>5.2</b>	<b>Preparing the IP 267</b> .....	<b>5 -</b>	<b>2</b>
5.2.1	Which Signals are Required for the Power Section? ....	5 -	2
5.2.2	Which Addresses are Assigned? .....	5 -	3
5.2.3	Preparing the Power Section .....	5 -	4
<b>5.3</b>	<b>Startup of the Plant</b> .....	<b>5 -</b>	<b>5</b>
<b>5.4</b>	<b>Determining a Reference Point</b> .....	<b>5 -</b>	<b>8</b>
5.4.1	Determining a Reference Point with Separate Switch ..	5 -	8
5.4.2	Determining a Reference Point with Limit Switches ....	5 -	9
<b>5.5</b>	<b>Notes for Direct Data Entry with Programmers or Operator Panels</b> .....	<b>5 -</b>	<b>10</b>
<b>5.6</b>	<b>Motor Selection</b> .....	<b>5 -</b>	<b>12</b>
5.6.1	Determining the Motor Identification Data .....	5 -	13
5.6.2	Selecting the Power Section .....	5 -	14
<b>5.7</b>	<b>Diagnostics Sheet</b> .....	<b>5 -</b>	<b>16</b>

<b>Figures</b>		
5-1.	Typical Data Exchange Between the CPU and the IP 267 (in Slot 3) .....	5 - 3
5-2.	Arrangement of Limit Switches and Emergency Limit Switches .....	5 - 5
5-3.	Distances Between Limit Switches and Emergency Limit Switches .....	5 - 7
5-4.	Reference Point Calculation with the REF Switch .....	5 - 10
5-5.	Determining a Reference Point with the I+ Switch .....	5 - 10
5-6.	Typical Torque Characteristic as a Function of the Frequency of a Stepper Motor .....	5 - 14
<b>Tables</b>		
5-1.	Addressing the Modules .....	5 - 3
5-2.	Connector Assignments IP 267 (6ES5 267-8MA 11) .....	5 - 4
5-3.	Output Signals of the IP 267 .....	5 - 15

## 5 Notes on Operation

Please ensure that your programmable controller meets the following requirements:

- The S5-100U is properly installed and wired;
- The power supply unit is connected according to regulations ( S5-100U Manual);
- The CPU of the S5-100U can work with the IP 267 ( Preface).

You require a programmer (PG 605/615/635/675/685/695 or 750) with the STEP 5 programming package for configuring and programming the IP 267.

### 5.1 Safety Concept

The following switching elements are indispensable to the safety concept of the system and must therefore be installed with great care and adapted to the conditions of the system:

- Emergency OFF switches, with which you can switch off the whole system ( Caution block on the next page).
- Limit switches, with which you limit the traversing range. These switches initiate programmed deceleration and can be connected to the digital inputs I + and I - as NCs or NOs.
- Two emergency limit switches, which only respond after a limit switch has responded. The input PD is always "0" active, i.e. this circuit is closed-circuit protected. You can only use NCs as emergency limit switches (PDs) and combinations of emergency limit switches (PDs) must always be connected in series. These switches disable pulse output immediately and they must be connected to the digital input PD of the IP 267. When making these connections, please observe the required clearances between PD and I + and I - ( Figure 5-3.).

**WARNING**

The IP 267 safety switches (limit switches, emergency limit switches, STOP switches) can stop the stepper motor but the motor windings are not then completely free of current. The residual current still flowing holds the motor in position. You may not be able to move the drive out of the danger zone in emergencies.

For this reason, you should install an emergency OFF switch to switch off the power section.

## 5.2 Preparing the IP 267

The IP 267 offers a variety of connections so please make sure which signals and signal levels you require for your system and tick the marked fields where required.

### 5.2.1 Which Signals are Required for the Power Section?

- 5 V differential inputs or 5 V optocoupler inputs. ( )  
Set the sliding switch on the frontplate of the IP 267 to "5 V".
- 5 V to 20 V inputs, special voltage  $V_S$ . ( )  
Set the sliding switch on the frontplate of the IP 267 to " $V_S$ ".

### 5.2.2 Which Addresses are Assigned?

- The IP 267 assigns addresses in the analog range of the S5-100U. The module addresses are preset by the fixed slot addressing of the programmable controller. You can operate the IP 267 in slots 0 to 7 ( Table 5-1.). Eight bytes are reserved per slot and the first four of these bytes are assigned.

**Table 5-1. Addressing the Modules**

PS	CPU	Slot							
		0	1	2	3	4	5	6	7
Analog addresses		64	72	80	88	96	104	112	120
		to 71	to 79	to 87	to 95	to 103	to 111	to 119	to 127

- If you use the IP 267 in slot 3 of the programmable controller, for example, bytes 88 to 91 in the process output image (PIQ) and the process input image (PII) are used for communication between the CPU and the IP 267. The other four bytes remain unused. You can reference these addresses with the STEP 5 load and transfer operations ( Figure 5-1.), to exchange input/output messages between the CPU of the programmable controller and the IP 267.

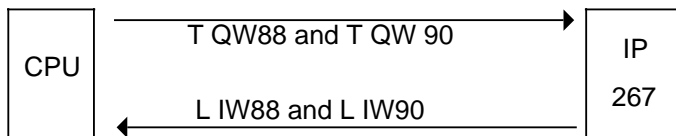

**Figure 5-1. Typical Data Exchange Between the CPU and the IP 267 (in Slot**

**Slot used :** .....

**First address byte :** .....

### 5.2.3 Preparing the Power Section

Connect the signal cables to the power section. Observe the manufacturer's instructions. Tick the connections used one after the other in the "Power section" field, where required.

**Table 5-2. Connector Assignments IP 267 (6ES5 267 8-MA11)**

9-way subminiature D connector	Colour code	Power section
1 : ---		
2 : Clock	white	( )
3 : ---		
4 : Clock inverted	brown	( )
5 : ---		
6 : ---		
7 : Direction level	green	( )
8 : Direction level inverted	yellow	( )
9 : NL ground	grey	( )

The cable shielding is connected to the connector shell.

- Set the desired operating mode (full-step or half-step) on the power section.
- Wire the enable signals for the power section if required (current drop, boost, etc.).
- Connect the cables to the IP 267.
- Connect the limit switches, emergency limit switches, BEROs etc. with the digital inputs on the IP 267 terminal block.
- If you use the special voltage  $V_s$  for the signals to the power section, you must connect the negative pole of  $V_s$  to the ground of the programmable controller (terminal block, terminal 2). The plus pole of  $V_s$  is connected to terminal 9 of the terminal block.
- All connections must be screwed tight for safety reasons.

### 5.3 Startup of the Plant

Check once more the function of your emergency OFF facility as well as the limit switches and the emergency limit switches (PD) before you switch the plant on. The emergency limit switches must always be connected in series. The limit switch actuators (on machine slides, etc.) must be located on axes within the switching range ( Figure 5.2.). If this is not the case, you must rotate the axes manually to within the desired range.

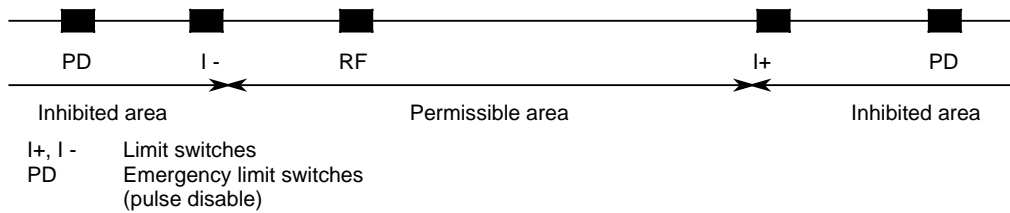

**Figure 5-2. Arrangement of Limit Switches and Emergency Limit Switches**

After checking all connecting cables, you can switch on the individual power sources, observing the following order:

- Switch on the programmable controller, no LEDs should light up on the IP 267 until it is configured.
- If you are using special voltage  $V_s$ , switch  $V_s$  on.
- Now switch on the power section.

Connect the programmer to the CPU and load the STEP 5 package into the programmable controller.

The green "RDY" LED on the frontplate of the IP 267 lights up after it has received the data.

**Note:**

If you send the output message frames to the IP 267 with the "FORCE VAR" programmer function during startup, there are important points you must note ( 5.5 ).

**WARNING**

When carrying out the following steps, make sure that the motors can be switched off at all times (emergency OFF switches or limit switches must be within easy reach). Assign only traversing jobs with low velocity steps at first.

- Transfer a "Forwards" or "Backwards" job with a short path and low velocity. The drive must move smoothly.
- Check the function of the emergency limit switches (PD) acting directly on the pulse disable.
- Check the correct execution of the "Forwards" and "Backwards" modes and, if necessary, interchange the RP and RP-N signal wires at the power section.
- Test both limit switches (I +, I -) acting on the IP 267. Limit switch I + must respond at the end of the forwards approach and I - must respond at the end of the backwards approach, otherwise you must change over the EPLUS and EMINUS connections at the digital inputs of the IP 267 ( 3.3 ).
- The input "External STOP" must be connected as specified in the configuration data ("0" active or "1" active).



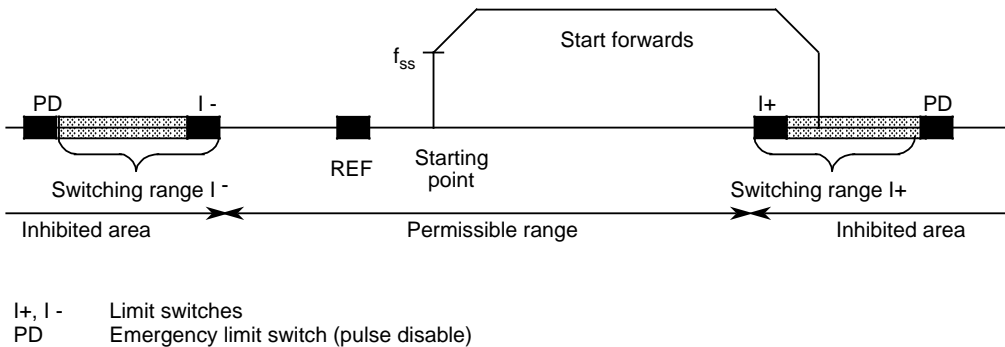

**Figure 5-3. Distances Between Limit Switches and Emergency Limit Switches**

- Make sure there is a sufficient distance between the limit switches and the emergency limit switches. This distance depends on the particular application. If the drive approaches the I + or I - switching points at (normal) maximum velocity, it must come to a standstill before reaching the emergency limit switch (PD). If an emergency limit switch responds, the IP 267 is disabled. You must reconfigure the IP 267 before it can accept further positioning jobs.
- Execute a reference point approach ( 5.4.)
- Test the external STOP function ( 3.4.)

5

### CAUTION

When a limit switch is operated, the IP 267 aborts the positioning procedures and disables all further jobs with the same direction of approach. The disable is only cancelled when a positioning job is executed in the opposite direction or if "STOP"/"Neutral" is programmed. If the axis does not leave the "inhibited" traversing range during this approach and if the limit switch gives no contact, an approach in the direction of PD would then be possible ( Figure 5-3.). To make sure that no positioning job can be started from the "inhibited" range (i.e. between limit switches and emergency limit switches PD) in the direction of PD, the switching range of the limit switches must be as wide as the total inhibited range ( Figure 5-3.).

## 5.4 Determining a Reference Point

Reference points calibrate the drive system and determine a system zero point for the following positioning jobs. To calculate the reference point, you can install a separate switch (position switch, BERO, etc.) within the traversing range that will send a signal to the REF reference input when triggered. You can, however, also use one of the limit switches for this purpose. In this case, the REF input remains unassigned. The IP 267 evaluates a REF signal only if the RPA bit in the positioning message frame is set. A reference point will exactly be reproduced each time it is approached from the same direction. The direction need only be laid down once.

The reference point approach must always be executed during commissioning, after power failure or after operation of the emergency limit switch (PD).

The reference point approach is calculated in three steps:

- Search for reference switch
- Overtravel reference switch
- Approach reference switch (slowly)

### 5.4.1 Determining a Reference Point with Separate Switch

To calculate the reference point start by initiating a positioning job in any direction. Set, for example, "Start forwards" mode with high velocity. The RPA bit is set and the maximum path is transferred.

When the module detects the reference switch (REF input activated), it stops with a slight delay. If the reference point is not found in this direction, the traversing path ends for the time being at limit switch I+.

In both cases, you must then assign a positioning job with the same parameters but with "Start backwards". This traversing movement is aborted with the reference switch. The contact of the reference switch should not be blocked at the end of the traversing movement. You will otherwise have to program an auxiliary approach section with the same direction of travel and RPA = 0 to enable the switch contact again ( 6.4.1).

Then you assign a "Start forwards" job setting a start/stop rate. Pulse output immediately stops when the reference switch is detected. The position reached is the reference point for further positioning jobs.

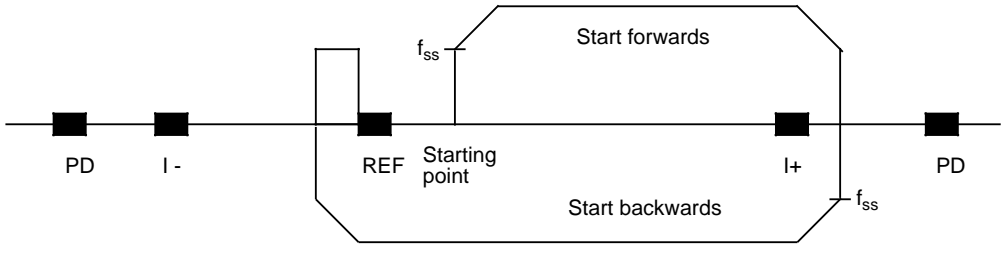

Figure 5-4. Reference Point Calculation with the REF Switch

### 5.4.2 Determining a Reference Point with Limit Switches

If you select limit switch I+, for example, as the reference switch, start a positioning job with high velocity, "Start forwards" and maximum path. The traversing movement is ended with the deceleration ramp at the limit switch.

The limit switch is then left at low velocity with the "Start backwards" job.

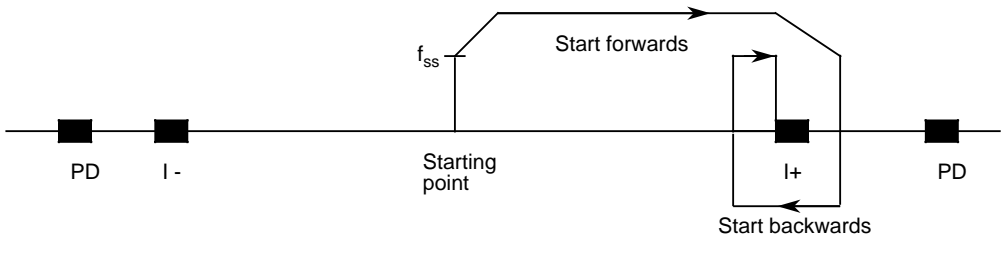

Figure 5-5. Determining a Reference Point with the I+ Switch

You then continue to the limit switch with "Start forwards" and at the start/stop rate. The traversing movement stops immediately when the limit switch is reached. You can re-establish this reference point at any time with step accuracy if you approach it with the same pulse frequency from the same direction.

**Note:**

Contact bounce at the REF, EMINUS and EPLUS inputs are compensated for by the module. This delays signal processing. To enable the IP 267 to reproduce reference points exactly, the periode of the step frequency must be greater than the signal delay. You must therefore approach the reference points with step frequencies of less than 100 Hz. In the case of start/stop rates greater than 100 Hz, you can decrease the relevant step frequency by the reduction factor R in the current positioning job - i.e. without reconfiguring.

## 5.5 Notes for Direct Data Entry with Programmers or Operator Panels

You can transfer data from programmers or operator panels (OPs) to the PC. When the transfer command is entered in the "FORCE VAR" mode of the programmer or from the operator panel, the interface transfers data byte-wise to the CPU at a baud rate of 9600 bits/s (=1 byte per 850  $\mu$ s).

When the first byte has been completely transferred to the CPU, the processor in the CPU initiates an interrupt. Cyclic processing of the program is interrupted and the transferred byte is written into the PIQ. Cyclical processing of the program is then continued until the second byte has been completely transferred by the interface. As soon as the second byte has been completely transferred to the CPU, the processor in the CPU initiates a further interrupt in order to transfer the second byte to the PIQ, and so on.

The various interrupts are separated by a delay of approximately 850  $\mu$ s during which the cyclic program is processed. This corresponds to approximately 10 statements in the case of the CPU 100. Processing of an output message can lead to errors under certain circumstances if a new "Start forwards" command is transferred from the PIQ to the IP 267 and is already being processed even though the relevant new path is not yet available, e.g. because an OB1 scan was completed during the interrupt sequence.

**Note:**

Configuring messages and positioning message frames must be transferred from the programmer/OP to the PIQ in one scan, otherwise the desired IP 267 response is not guaranteed.

You can use the following programming mode to ensure that output messages are only processed en bloc, i.e. they are only transferred to the IP 267 when they are complete in the PIQ.

OB 1		PB 1	
:			
:		R	F 0.0
:		L	FW 10
A	F 0.0	T	QW 88
JC	PB1	L	FW 12
:		T	QW 90
:		BE	

The data (QW88, QW90) is not written direct into the PIQ from the operator panel but in data words (DW10, DW12). Only then can you set flag F 0.0 on the operator panel. By doing so you make sure that PB1 can only be called if all the data is valid. The data is then transferred en bloc by PB1 to the PIQ and, consequently, to the IP.

If F 0.0 is set immediately in the operator panel display, the conditional jump to PB1 can take place before data words DW 10 and DW 12 contain the desired data.

Configuring message frames must also be transferred from the programmer/OP to the PIQ within one scan. If this is not the case, the IP 267 receives message frames which are only partly updated. If these configuring message frames are recognized by the IP 267 (multiplier for the start/stop rate not zero and "STOP" mode in the PIQ), the following errors can occur under certain circumstances:

- The time interval is interpreted by the IP 267 with the old value of the relevant byte
- Wrong frequency range
- Wrong limit switch configuration
- ...

## 5.6 Motor Selection

Please note the following points when selecting a motor:

- Can the stepper motor develop the required torque?
- Can load variations occur that might lead to step losses (load torque temporarily greater than motor torque)?
- Does the actual position have to be checked using an additional position encoder? (e.g. using a stepper motor with integral encoder and with a 25/500 kHz counter module, Order No. 6ES5 385-8MB11)
- Would it be advisable to use a drive unit capable of detecting and correcting step losses?

If a stepper motor meets the above requirements, there are still the following selection criteria to be taken into account (mechanical dimensions and designs are ignored here):

- How great is the maximum load torque?
- Up to what pulse frequency can the motor develop the required torque?
- How great must the number of steps of the motor be to reach the required path resolution?

### 5.6.1 Determining the Motor Identification Data

Required path resolution  $k = \dots\dots\dots \mu\text{m/pulse}$

Required traversing velocity  $V_{\text{max}} = \dots\dots\dots \text{mm/min}$

Max. load torque at the motor shaft  $M_{\text{max}} = \dots\dots\dots \text{Ncm}$

The ratio  $\ddot{u}$  of the shaft and the number of pulses per revolution  $m$  of the motor must be selected so that their quotient results in the required resolution  $k$ :

$$\ddot{u} = m * k \qquad m = \dots\dots\dots \text{pulses/rev}$$

$$k = \ddot{u} / m \qquad \ddot{u} = \dots\dots\dots \text{mm/rev}$$

The maximum pulse frequency  $f_{\text{max}}$  is calculated as follows:

$$f_{\text{max}} \text{ [kHz]} = \frac{V_{\text{max}} \text{ (mm/min)}}{k * 60 \text{ (mm/pulse)}}$$

A type must now be selected from the characteristic curves of the motors capable of developing the required torque, without step loss, at the calculated frequency  $f_{\text{max}}$ .



Figure 5-6. shows a typical stepper motor curve. See 6.6 for an application example.

**Note:**  
 If the desired torque characteristic can be implemented with the selected motor only in half-step mode, you must double the frequency in order to achieve the same velocity in full-step mode. The resolution doubles in this case since only half the path is covered with each pulse.

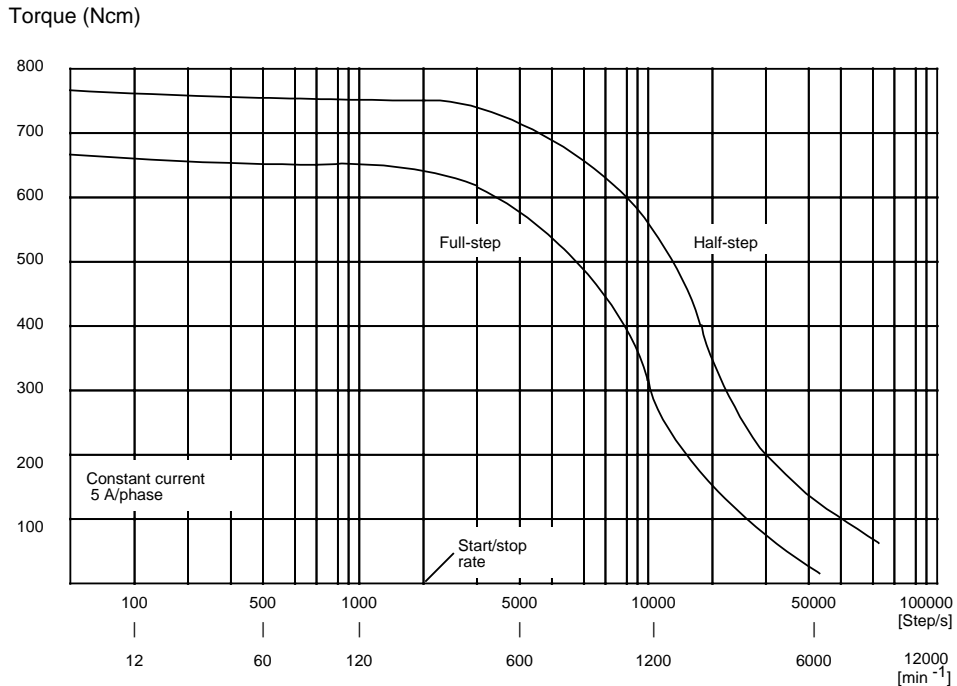

**Figure 5-6. Typical Torque Characteristic as a Function of the Frequency of a Stepper Motor**

## 5.6.2 Selecting the Power Section

The IP 267 sends the signals listed in Table 5-3 as 5 V differential signals (standard). A special voltage of 5 V to 30 V can also be used. This voltage must apply externally to the IP 267 terminal block. Select your power section so that it can also process the highest pulse frequency  $f_{\max}$ .



**Table 5-3. Output Signals of the IP 267**

Signal	Signal	IP 267 Pulse duration µs	Power section requires:		
			Signal	Level V	Duration µs
Clock pulse TN	TN	1 - 3 - 7 15 - 31 - 63			
	TN\*	127 - 255			
Direction level	RP	Voltage level for forwards or backwards motion			
	RP\*				

\* inverted signals

You can enter the required signal configuration for the power section in the right-hand column of Table 5-3.

## 5.7 Diagnostics sheet

Description of error/fault	Possible sources of error
Module cannot be configured	<ul style="list-style-type: none"> <li>- Module addressing incorrect</li> <li>- IP 267 has been configured using a programmer with the "Force variable" function or using an OP ( Notes 5.5)</li> <li>- Old configuration has not been deleted</li> </ul>
Module parameters can be set but module signals "Abort" (red "ABT" LED lights up).	<ul style="list-style-type: none"> <li>- External STOP, limit switch or emergency limit switch (PD) active</li> <li>- IP267 has been configured using a programmer with the "Force variable" function or using an OP ( Notes 5.5)</li> </ul>
Motor "howls" but does not move.	Start/stop rate or acceleration too high
Motor jerks and remains still.	Frequency increase too high (time intervals too small). Note resonant frequencies of drive
Motor accelerates and then remains still and howls.	Output frequency or load torque too high. Voltage for operating motor is too low
The signals are present at the output of the IP but the motor does not move.	<ul style="list-style-type: none"> <li>- Signal cables to IP connector have been crossed.</li> <li>- Does the power section need a separate enable signal?</li> </ul>
No output signals can be measured although the distance to go has been counted.	<ul style="list-style-type: none"> <li>- Special voltage <math>V_S</math> not connected correctly.</li> </ul>
The module does not switch to the "Pulse output" status in the case of "Forwards" or "Backwards" mode.	<ul style="list-style-type: none"> <li>- External limit switch (PD) active</li> <li>- External STOP active</li> <li>- REF input active and the RPA (reference point approach) set</li> <li>- Limit switch start (I -) or end (I+) has already been actuated in backwards or forwards mode</li> <li>- Time interval (TI) has been set equal to zero in the configuring data</li> <li>- "Forwards" or "Backwards" mode has already been selected so that the module now receives no valid traversing command.</li> </ul>

## 6 Application Examples

<b>6.1</b>	<b>Configuring and Reconfiguring the IP 267</b> .....	<b>6 - 2</b>
6.1.1	Programming Example "Reconfiguring the IP 267" .....	6 - 3
<b>6.2</b>	<b>Fixed Positions</b> .....	<b>6 - 6</b>
6.2.1	Program Example "Transferring Positioning Jobs to the IP 267" .....	6 - 7
<b>6.3</b>	<b>Parameter Transfer Using Digital Input Modules</b> .....	<b>6 - 11</b>
6.3.1	Program Example "Positioning Job" .....	6 - 11
<b>6.4</b>	<b>Determining Reference Points with Separate Switch</b> ...	<b>6 - 14</b>
6.4.1	Program Example "Reference Point Approach with Separate Switch" .....	6 - 15
<b>6.5</b>	<b>Reference Point Approach with Limit Switch</b> .....	<b>6 - 20</b>
6.5.1	Program Example: "Reference Point Approach with Limit Switch" .....	6 - 21
<b>6.6</b>	<b>Loading and Unloading a Waggon</b> .....	<b>6 - 25</b>
6.6.1	Selecting the Motor .....	6 - 26
6.6.2	Setting the Configuration Data .....	6 - 26
6.6.3	Configuration Data for the Path C to A .....	6 - 27
6.6.4	Configuration Data for the Paths A to B and B to C .....	6 - 31
6.6.5	Positioning Job C to A .....	6 - 34
6.6.6	Positioning Job A to B .....	6 - 35
6.6.7	Positioning Job B to C .....	6 - 37
6.6.8	Linking to the User Program .....	6 - 38
6.6.9	Program Example "Loading and Unloading a Waggon"	6 - 39

<b>Figures</b>		
6-1.	Flowchart for Programming Example "Reconfiguring"	6 - 3
6-2.	Flowchart "Transferring Positioning Jobs"	6 - 7
6-3.	Flowchart "Reference Point Approach with Separate Switch"	6 - 15
6-4.	Flowchart for Programming Example "Reference Point Approach with Limit Switch"	6 - 21
6-5.	Arrangement of the Silos Along the Path	6 - 25
6-6.	Example of Moment of Inertia as a Function of $f_{ss}$	6 - 28
6-7.	Structure of the User Program "Loading and Unloading a Waggon"	6 - 38
<b>Tables</b>		
6-1.	Path Breakdown	6 - 25
6-2.	Configuration Message Frame for the Path C to A	6 - 30
6-3.	Configuration Message Frame for the Paths A to B and B to C	6 - 33
6-4.	Positioning Job for the Path C to A	6 - 35
6-5.	Positioning Job for the Path A to B	6 - 36
6-6.	Positioning Job for Path B to C	6 - 37

## 6 Application Examples

The IP 267 occupies slot 3 of the programmable controller in all examples. The input/output message frames are therefore written into byte addresses 88 to 91. All program examples can run on all CPUs (CPU 100, 102 and 103) of the S5-100U. Examples 1 to 5 are based on the block principle, i.e. certain program sections (FBs and OBs) of the previous example are used in the subsequent examples. The examples are structured as follows:

Example 1 ( 6.1) covers: Configuring/reconfiguring the IP 267

Example 2 ( 6.2) covers: Example 1 and fixed positioning jobs

Example 3 ( 6.3) covers: Example 2 and starting of positioning jobs via digital I/Os

Example 4 ( 6.4) covers: Example 3 and reference point approach with separate switch

Example 5 ( 6.5) covers: Example 4 and reference point approach with limit switch

Example 6 contains only autonomous program sections. You can start this program without loading the other example programs into the PC memory.

The examples are designed only to illustrate the principle involved in programming the IP 267. They are therefore extensively documented and the statement lists contain comments. Each programming example represents only one of several possible solutions.

## 6.1 Configuring and Reconfiguring the IP 267

In the following example, the IP 267 is configured with new data at each cold restart or warm restart.

A configuration always requires two subsequent message frames. The first message frame deletes the current IP 267 configuration data and the second reconfigures the IP 267.

Data is exchanged between the IP 267 and the CPU exclusively via the process I/O images (PII and PIQ). The PIQ must contain the complete message frame and the first OB 1 scan must be complete before the second message frame is then transferred to output words QW 88 and QW 90 in the next program scan. Otherwise the IP 267 receives only the second message frame. If the old data is still available in the IP 267, the second message frame is interpreted as a positioning job with the "STOP" mode and not as the configuration message frame.

Please note the following when programming warm restart routines in OB 21 or OB 22:

- After switching on the CPU, the configuration message frame at the end of the first OB 1 scan is transferred to the IP. The message frame may not be changed during the first OB1 processing.
- Overall reset of the IP 267 occurs after power failure and can be reconfigured with OB 22.
- The PIQ is reset in the case of manual cold restart and the IP configuration data is still available. This configuration data can only be deleted if the contents of the PIQ are still reset after the first cyclic scan of OB 1. Otherwise the IP 267 interprets a configuration message frame in OB 21 as being a positioning job with "STOP" mode ( 6.1.1).

### 6.1.1 Programming Example "Reconfiguring the IP 267"

The IP 267 can be reconfigured with function block FB 50. FB 50 is executed twice when flag F 101.6 is set (see OB1). The present configuration data is deleted during the first run and then the IP 267 is reconfigured. Flag F 101.6 can be set in the warm restart OBs (OB 21 and OB 22).

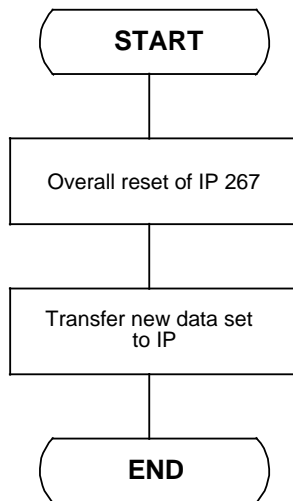

**Figure 6-1. Flowchart for Programming Example "Reconfiguring"**



FB 50

LEN=42

ABS

PAGE 1

SEGMENT 1 0000

NAME :PARAMETR

0005 :A F 101.7

0006 :JC =M001

0007 :

0008 :

0009 :S F 101.7

000A :L KH 0000

000C :T QW 88

000D :BEC

000E :

000F :

0010 M001 :L KH 0402

0012 :T QW 88

0013 :L KH 2005

0015 :T QW 90

0016 :

0017 :

0018 :

0019 :

ACTIVE

001A :

001B :

001C :

001D :

001E :

001F :R F 101.7

0020 :R F 101.6

0021 :S F 101.5

0022 :

0023 :

0024 :BE

FIRST FB50 CALL :

THE EXISTING CONFIGURATION DATA

IS DELETED

SECOND FB50 CALL :

NEW CONFIGURATION DATA

IS TRANSFERRED COMPLETE :

QB91 = 05H ----&gt; BASE VALUE = 20 HZ

QB90 = 20H ----&gt; TIME INTERVAL

QB89 = 02H ----&gt; OPERATING MODE = STOP

FULL STEP OPERATION

LIM. SWITCH "1"

QB88 = 04H ----&gt; SSF = BB \* 4

= 80 HZ

SECOND FB50 CALL :

RESET AUXILIARY FLAG F101.7

RESET CONTROL FLAG F101.6

SET AUXILIARY FLAG F101.5



```

OB 1                                     LEN=22      ABS
SEGMENT 1      0000
0000          :
0001          :A  F   101.6      FLAG F101.6 CAN BE RESET
0002          :JC FB 50          IN THE WARM RESTART OBS,
                                FOR EXAMPLE
0003 NAME :PARAMETR
0004          :
0005          :O  F   101.5      BOTH RECONFIGURATION
0006          :O  F   101.6      MESSAGE FRAMES CAN BE SENT
0007          :R  F   101.5      TO THE IP 267 DIRECT
0008          :BEC              WITH THIS BEC
0009          :
000A          :
000B          :
000C          :                .... THEN USER PROGRAM ...
000D          :
000E          :
000F          :
0010          :BE

```

```

OB 21                                     LEN=9      ABS
SEGMENT 1      0000
0000          :AN  F   101.6
0001          :S  F   101.6
0002          :
0003          :BE

```

```

OB 22                                     LEN=9      ABS
SEGMENT 1      0000
0000          :AN  F   101.6
0001          :S  F   101.6
0002          :
0003          :BE

```

## 6.2 Fixed Positions

The IP 267 is already configured in this example. The program example shows how to start a positioning program with four jobs automatically at the press of a button. In this example, the feedback messages "Pulse output" and "Job executing" after a positioning job are not set in the PII till one scan later ( 4.3).

## 6.2.1 Program Example "Transferring Positioning Jobs to the IP 267"

In this example, four positioning jobs are transferred one after the other to the IP 267 by function block FB 51.

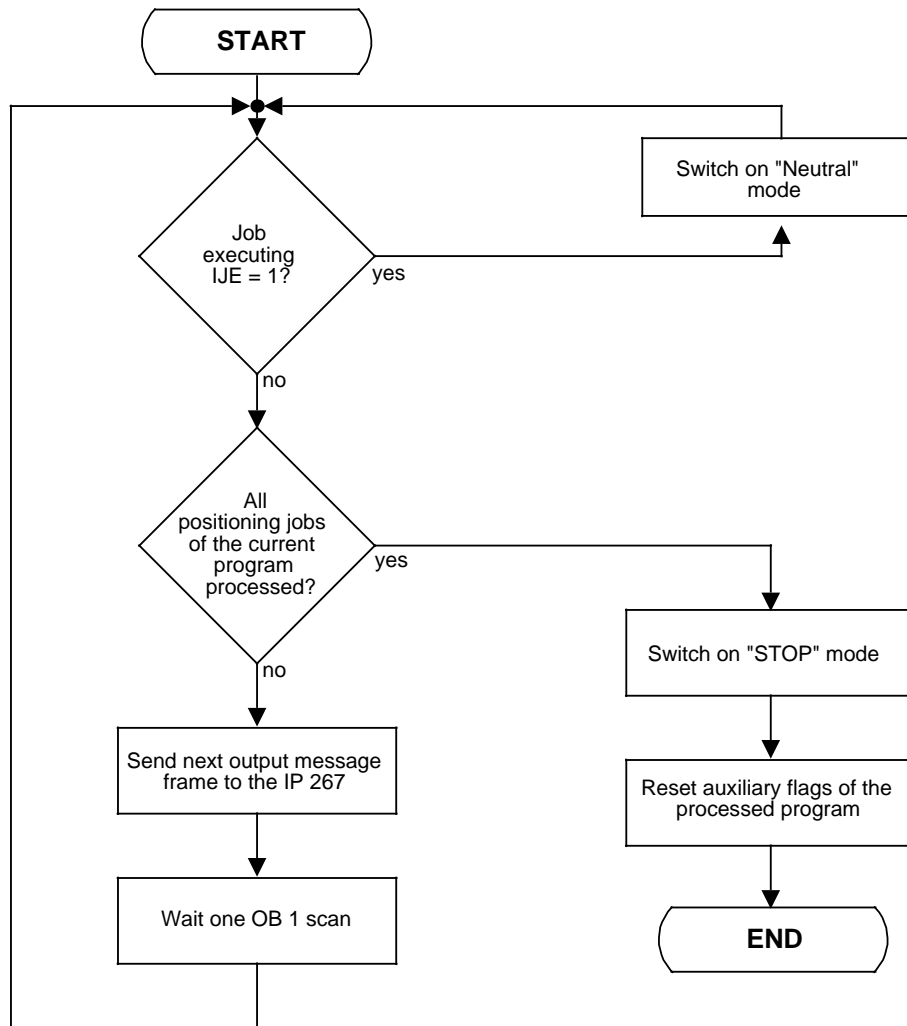

Figure 6-2. Flowchart "Transferring Positioning Jobs"

```

                                0024      :
FB 51                            LEN=77      ABS      0025      :
                                PAGE 1

```

```
SEGMENT 1      0000
```

FOUR POSITIONING JOBS CAN BE PROCESSED ONE AFTER THE OTHER AUTOMATICALLY WITH FB51 :

```

FIRST JOB  ----->  FORWARDS,   SPEED A,  TARGET A
SECOND JOB ----->  BACKWARDS,  SPEED B,  TARGET B
THIRD JOB  ----->  FORWARDS,   SPEED C,  TARGET C
FOURTH JOB ----->  FORWARDS,   SPEED D,  TARGET D

```

THE PROGRAM IS STARTED BY WITH A POSITIVE EDGE AT I0.0 (SEE OBI).

THE LIMIT SWITCHES MUST NOT BE ACTUATED IN THIS PROGRAM, OTHERWISE THE POSITIONING VALUES WILL BE CORRUPTED. THE RESPONSE OF A DRIVE TO THE OPERATION OF A LIMIT SWITCH SHOULD BE PROGRAMMED BY THE USER.

NAME :FEST-VP

```

0005      :
0006      :A  I  89.6           SWITCH ON "NEUTRAL" MODE
0007      :S  Q  89.4           AS SOON AS THE CURRENT
0008      :S  Q  89.5           POSITIONING JOB IS
0009      :BEC                 EXECUTED
000A      :
000B      :
000C      :A  F  103.0          THE FIRST POSITIONING JOB
000D      :JC =M001            IS TRANSFERRED TO THE PIQ
000E      :S  F  103.0          WITH THIS SEQUENCE
000F      :S  F  103.7
0010      :L  KH 2010           FLAGS F103.X ARE THE
0012      :T  QW 88             AUXILIARY FLAGS
0013      :L  KH 2000
0015      :T  QW 90
0016      :BEU
0017      :
0018      :
0019 M001 :A  F  103.1
001A      :SPB =M002
001B      :S  F  103.1
001C      :S  F  103.7          THE SECOND POSITIONING JOB
001D      :L  KH 3020          IS TRANSFERRED TO THE PIQ
001F      :T  QW 88             WITH THIS SEQUENCE
0020      :L  KH 4000
0022      :T  QW 90
0023      :BEU

```

```

0026 M002 :A F 103.2
0027      :JC =M003
0028      :S F 103.2
0029      :S F 103.7
002A     :L KH 1010
002C     :T QW 88
002D     :L KH 0800
002F     :T QW 90
0030     :BEU
0031     :
0032     :
0033 M003 :A F 103.3
0034      :JC =M004
0035      :S F 103.3
0036      :S F 103.7
0037      :L KH 4010
0039      :T QW 88
003A     :L KH 1800
003C     :T QW 90
003D     :BEU
003E     :
003F     :
0040 M004 :R F 101.0AT
0041      :R Q 89.4
0042      :R Q 89.5
0043      :L KB 0
0044      :T FY 103
0045     :
0046     :
0047     :BE

```

THE THIRD POSITIONING JOB  
IS TRANSFERRED TO THE PIQ  
WITH THIS SEQUENCE

THEFOURTH POSITIONING JOB  
IS TRANSFERRED TO THE PIQ  
WITH THIS SEQUENCE

THE END OF THE POSITIONING PROGRAM,  
THE AUXILIARY FLAGS ARE RESET AND  
THE "STOP" MODE IS SWITCHED ON

6

```

OB 1
SEGMENT 1 0000
0000      :
0001      :A F 101.6
0002      :JC FB 50
0003 NAME :PARAMETR
0004      :
0005      :O F 101.5
0006      :O F 101.6
0007      :R F 101.5
0008      :BEC
0009      :
000A     :

```

LEN=36 ABS

FLAG F 101.6 CAN BE SET IN  
THE WARM RESTART OBS,  
FOR EXAMPLE

BOTH CONFIGURATION MESSAGE FRAMES  
CAN BE TRANSFERRED DIRECT TO THE  
IP 267 WITH THIS BEC

```
000B      :A  I   0.0          ROUTINE FOR FIXED
000C      :S  F  101.0        POSITIONING JOBS
000D      :
000E      :
000F      :A  F  101.7        FLAG F 103.7 REMAINS SET UNTIL THE
0010      :R  F  101.7        CURRENT POSITIONING JOB HAS BEEN
0011      :BEC                EXECUTED. "NEUTRAL" MODE IS THEN
0012      :                    SWITCHED ON. (CPU WAIT CYCLE)
0013      :
0014      :A  F  101.0
0015      :JC FB  51
0016 NAME :FEST-VP
0017      :
0018      :
0019      :                    .... THEN USER PROGRAM ...
001A      :BE
```

```
OB 21                                LEN=9      ABS
SEGMENT 1      0000
0000          :AN  F  101.6
0001          :S  F  101.6
0002          :
0003          :BE
```

```
OB 22                                LEN=9      ABS
SEGMENT 1      0000
0000          :AN  F  101.6
0001          :S  F  101.6
0002          :
0003          :BE
```

### 6.3 Parameter Transfer Using Digital Input Modules

In this example, the parameters for the positioning job are transferred to the PIQ using digital input modules. The complete output message frame is to be transferred to the PIQ in one scan. If this principle cannot be followed, it is important to transfer the "Forwards" or "Backwards" mode to the IP 267 as the last parameter of the output message frame in the case of preset positioning jobs, as otherwise the IP 267 will start the positioning job immediately, i.e. with an old velocity factor or a wrong path.

#### 6.3.1 Program Example "Positioning Job"

```

PB 52                                LEN=16      ABS
                                         PAGE  1
SEGMENT 1      0000

PB 52 TRANSFERS A POSITIONING JOB TO THE IP 267 :
-----> THE COMPLETE OUTPUT MESSAGE FRAME IS TO BE ENTERED VIA
          DIGITAL I/O (HERE IW4 AND IW6)
-----> THE JOB IS STARTED BY WITH A POSITIVE EDGE AT I 0.1 (TRANSFER
          OPERATION) (SEE OB1)

0000      :
0001      :R   F  101.1
0002      :
0003      :
0004      :L   IW   4
0005      :T   QW  88
0006      :L   IW   6
0007      :T   QW  90
0008      :
0009      :
000A      :BE
    
```



```

OB 1                                     LEN=42      ABS
SEGMENT 1      0000
0000      :
0001      :A  F  101.6      FLAG F 101.6 CAN BE SET
0002      :JC FB  50      IN THE WARM RESTART OBS,
                                FOR EXAMPLE
0003 NAME :PARAMETR
0004      :
0005      :O  F  101.5      BOTH RECONFIGURATION MESSAGE
0006      :O  F  101.6      FRAMES CAN BE TRANSFERRED
0007      :R  F  101.5      DIRECT TO THE IP 267
0008      :BEC      WITH THIS BEC
0009      :
000A      :
000B      :A  I   0.0      ROUTINE FOR FIXED
000C      :S  F  101.0      POSITIONING JOBS
000D      :
000E      :
000F      :      WITH FLAG F 103.7 THE PROGRAM
                                WAITS FOR THE POSITIONING JOB
0010      :A  F  103.7      TO BE EXECUTED BEFORE
0011      :R  F  103.7      SWITCHING TO "NEUTRAL" MODE
0012      :BEC      (CPU WAIT CYCLE).
0013      :
0014      :A  F  101.0
0015      :JC FB  51
0016 NAME :FEST-VP
0017      :
0018      :
0019      :A  I   0.1      ROUTINE FOR POSITIONING JOBS
001A      :S  F  101.1      THAT CAN BE SET VIA DIGITAL
001B      :A  F  101.1      INPUTS
001C      :JC PB  52
001D      :
001E      :
001F      :
0020      :      .... THEN USER PROGRAM ...
0021      :
0022      :
0023      :
0024      :BE

```



```
OB 21                                LEN=9      ABS
SEGMENT 1      0000
0000      :AN  F  101.6
0001      :S   F  101.6
0002      :
0003      :BE
```

```
OB 22                                LEN=9      ABS
SEGMENT 1      0000
0000      :AN  F  101.6
0001      :S   F  101.6
0002      :
0003      :BE
```

## 6.4 Determining Reference Points with Separate Switch

A reference point is always determined in three approach sections (search for reference point switch, overtravel reference point switch and approach reference point switch slowly). Additional auxiliary approach jobs are required, for example, if the reference switch is blocked by the drive.

At startup, the IP controls the drive forwards as far as the reference switch. In doing so, the IP can approach one of the two limit switches and change direction there. As soon as the reference point switch has been detected, the drive stops with the normal deceleration ramp. If the deceleration distance is shorter than the switching range of the reference point switch, the drive stops at the switch. In this case, the next approach section could not be executed because the RPA reference point bit is set and there is a "1" signal at the REF digital input.

In this case, an auxiliary approach section is required in order to leave the reference point switch. The path of such auxiliary approach sections must be calculated specifically for the plant in question. The auxiliary approach section must also be executed with reset RPA reference point bit ( 6.3).

To make program execution easier, the "Backwards auxiliary approach section" is executed in example program 4 even if the reference point switch has already been overtravelled (BERO, etc.).

The reference point can also be approached backwards, in which case the directions shown in the flowchart are reversed.

### 6.4.1 Program Example "Reference Point Approach with Separate Switch"

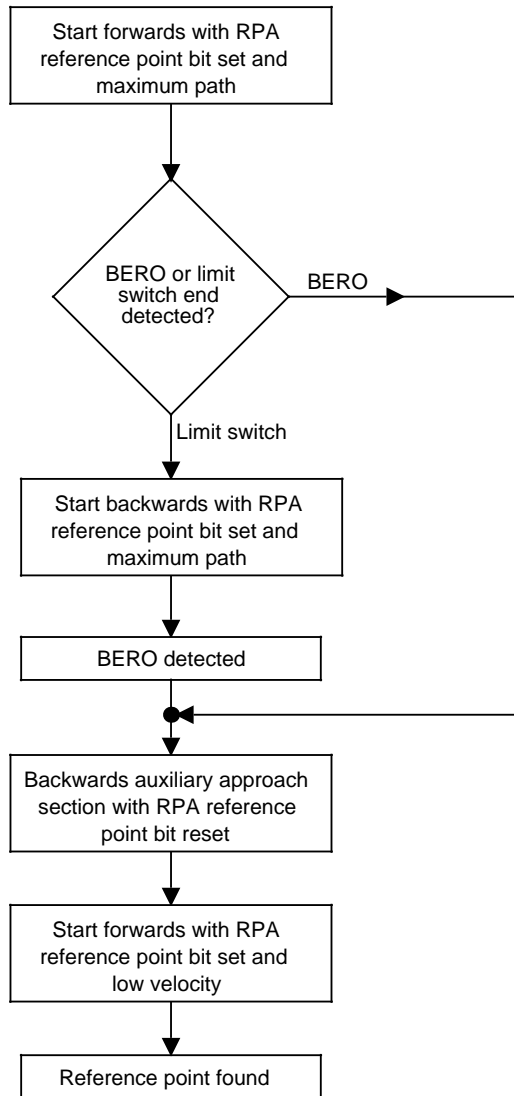

Figure 6-3. Flowchart "Reference Point Approach with Separate Switch"

FB 53

LEN=81

ABS

PAGE 1

SEGMENT 1 0000

FB53 EXECUTES THE REFERENCE POINT APPROACH USING A REFERENCE POINT SWITCH. THE POSITIONING JOBS ARE SET IN THE PIQ VIA DIRECT ACCESSES. THIS ROUTINE IS STARTED BY A POSITIVE EDGE AT I 0.2 (SEE OBL)

MEANING OF THE FLAGS USED :

F 104.0 FLAG BIT FOR THE FIRST APPROACH SECTION ( START FORWARDS )  
 F 104.1 FLAG BIT FOR THE SECOND APPROACH SECTION ( START BACKWARDS )  
 F 104.2 FLAG BIT FOR THE BACKWARDS AUXILIARY APPROACH SECTION  
 F 104.3 FLAG BIT FOR THE THIRD APPROACH SECTION ( START FORWARDS WITH LOW VELOCITY )  
 F 104.7 AUXILIARY FLAG TO ALLOW THE CPU DELAY CYCLE TO RUN

THE IP 267 IS INSTALLED IN SLOT 3 OF THE S5-100U IN THIS EXAMPLE  
 ( ADDRESS BYTES 88-89-90-91 )

I 88.1 REFERENCE POINT ( ERP )  
 I 88.5 PULSE OUTPUT ( EIA )

NAME :RPKT

0005	:A	I	88.5	IF PULSES ARE OUTPUT,
0006	:S	Q	89.4	SWITCH ON "NEUTRAL" MODE
0007	:S	Q	89.5	AND DO NOT PROCESS
0008	:BEC			THE FB
0009	:			
000A	:			
000B	:A	F	104.0	
000C	:JC	=M001		
000D	:S	F	104.0	
000E	:S	F	104.7	
000F	:L	KH	585F	FIRST APPROACH SECTION: FORW.
0011	:T	QW	88	WITH REFERENCE POINT BIT SET
0012	:L	KH	FFFF	AND MAXIMUM PATH
0014	:T	QW	90	
0015	:BEU			
0016	:			
0017	:			
0018	M001	:AN	F 104.1	OMIT THE 2ND APPROACH SECTION
0019	:A	I	88.1	IF THE BERO IS DETECTED
001A	:S	F	104.1	DURING THE FIRST APPROACH SECTION
001B	:JC	=M002		
001C	:			
001D	:			

```

001E      :A  F  104.1
001F      :JC =M002
0020      :S  F  104.1
0021      :S  F  104.7
0022      :L  KH 586F
0024      :T  QW  88
0025      :L  KH FFFF
0027      :T  QW  90
0028      :BEU
0029      :
002A      :
002B M002 :A  F  104.2
002C      :JC =M003
002D      :S  F  104.2
002E      :S  F  104.7
002F      :L  KH 2820
0031      :T  QW  88
0032      :L  KH 0300
0034      :T  QW  90
0035      :BEU
0036      :
0037      :
0038 M003 :A  F  104.3
0039      :JC =M004
003A      :S  F  104.3
003B      :S  F  104.7
003C      :L  KH 0150
003E      :T  QW  88
003F      :L  KH 4000
0041      :T  QW  90
0042      :BEU
0043      :
0044      :
0045 M004 :L  KB  0
0046      :T  FY  104
0047      :S  F  101.4
0048      :R  Q   89.5
0049      :R  Q   89.6
004A      :R  Q   89.8
004B      :
004C      :BE

```

SECOND APPROACH SECTION: BACKW.  
WITH REFERENCE POINT BIT SET  
AND MAXIMUM PATH

AUXILIARY APPROACH SECTION BACKW.  
WITHOUT REFERENCE POINT BIT TO  
MAKE SURE THAT THE DRIVE IS  
NO LONGER AT THE BERO. FOR THIS  
PURPOSE THE PATH MUST BE ADAPTED  
DEPENDING ON THE DRIVE.

THIRD APPROACH SECTION: FORW.  
WITH REFERENCE POINT BIT SET  
AND LOW VELOCITY

IF THE REFERENCE POINT APPROACH  
IS COMPLETE, RESET AUXILIARY FLAG  
AND SWITCH ON "STOP" MODE  
FLAG 101.4 IS NOT USED IN THIS  
EXAMPLE.

```

OB 1                                LEN=53      ABS
SEGMENT 1      0000
0000          :
0001          :A  F  101.6          FLAG F 101.6 CAN BE SET
0002          :JC FB  50          IN THE WARM RESTART OBS,
                                FOR EXAMPLE
0003 NAME :PARAMETR
0004          :
0005          :O  F  101.5          BOTH RECONFIGURATION MESSAGE
0006          :O  F  101.6          FRAMES CAN BE TRANSFERRED
0007          :R  F  101.5          DIRECT TO THE IP 267
0008          :BEC          WITH THIS BEC
0009          :
000A          :
000B          :A  I   0.0          ROUTINE FOR FIXED
000C          :S  F  101.0          POSITIONING JOBS
000D          :
000E          :
000F          :
0010          :A  F  103.7          WITH FLAG F 103.7 THE PROGRAM
0011          :R  F  103.7          WAITS FOR THE POSITIONING
0012          :BEC          JOB TO BE EXECUTED BEFORE
                                SWITCHING TO "NEUTRAL" MODE
0013          :
                                (CPU WAIT CYCLE)
0014          :A  F  101.0
0015          :JC FB  51
0016 NAME :FEST-VP
0017          :
0018          :
0019          :A  E   0.1          ROUTINE FOR POSITIONING
001A          :S  F  101.1          JOBS WHICH CAN BE SET VIA
001B          :A  F  101.1          DIGITAL INPUTS
001C          :JC PB  52
001D          :
001E          :
001F          :A  F  104.7
0020          :R  M  104.7
0021          :BEC          ROUTINE FOR REFERENCE POINT
0022          :
                                DETERMINATION WITH SEPARATE
0023          :A  I   0.2          BERO
0024          :S  F  104.6
0025          :A  F  104.6
0026          :JC FB  53
0027 NAME :RPKT
0028          :
0029          :
002A          :
                                .... THEN USER PROGRAM ...
002B          :
002C          :
002D          :
002E          :
002F          :BE

```

```
OB 21                                LEN=13      ABS
SEGMENT 1      0000
0000          :AN  F  101.6
0001          :S  F  101.6
0002          :
0003          :L  KF +0
0005          :T  FW 104
0006          :
0007          :BE
```

```
OB 22                                LEN=13      ABS
SEGMENT 1      0000
0000          :AN  F  101.6
0001          :S  F  101.6
0002          :
0003          :L  KF +0
0005          :T  FW 104
0006          :
0007          :BE
```

## 6.5 Reference Point Approach with Limit Switch

This method of determining the reference point also consists of three approach sections ( 5.4). A separate reference point switch is not required. The REF input on the terminal block remains unassigned and the RPA reference bit in the positioning message frame is not set. The path of the second approach section (switch overtravel) should be long enough to enable the limit switch contacts again.

You can execute a reference point approach with limit switch I+ using FB 54. A separate reference point switch is not required in this example. The positioning job data is written direct into the PIQ. The program is started by a positive edge at input I 0.3 (see OB 1).



### 6.5.1 Program Example: "Reference Point Approach with Limit Switch"

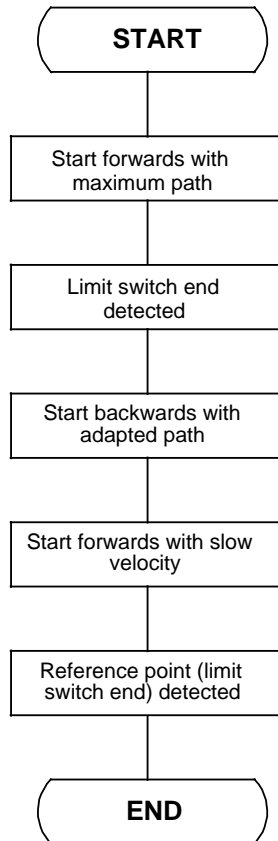

6

**Figure 6-4. Flowchart for Programming Example "Reference Point Approach with Limit Switch"**

FB 54

LEN=61

ABS

PAGE 1

MEANING OF THE FLAGS USED:

F 105.0 FLAG BIT FOR THE FIRST APPROACH SECTION ( START FORWARDS )  
 F 105.1 FLAG BIT FOR THE SECOND APPROACH SECTION ( START BACKWARDS )  
 F 105.2 FLAG BIT FOR THE THIRD APPROACH SECTION ( START FORWARDS WITH  
 LOW VELOCITY )  
 F 105.7 AUXILIARY FLAG TO ALLOW THE CPU DELAY CYCLE TO RUN  
  
 I 88.3 LIMIT SWITCH END ( ILSE )  
 I 88.5 PULSE OUTPUT ( IPQ )

NAME :EPKT

0005	:A	I	88.5	IF PULSES ARE OUTPUT,
0006	:S	Q	89.4	SWITCH ON "NEUTRAL" MODE
0007	:S	Q	89.5	AND DO NOT PROCESS
0008	:BEC			THE FB
0009	:			
000A	:			
000B	:A	F	105.0	
000C	:JC	=M001		
000D	:S	F	105.0	
000E	:S	F	105.7	
000F	:L	KH	581F	
0011	:T	QW	88	FIRST APPROACH SECTION: FORW.,
0012	:L	KH	FFFF	WITH MAXIMUM PATH
0014	:T	QW	90	
0015	:BEU			
0016	:			
0017	:			
0018	M001 :A	F	105.1	
0019	:JC	=M002		
001A	:S	F	105.1	
001B	:S	F	105.7	
001C	:L	KH	2820	
001E	:T	QW	88	SECOND APPROACH SECTION: BACKW.
001F	:L	KH	0380	WITH SHORT PATH
0021	:T	QW	90	
0022	:BEU			
0023	:			
0024	:			

```
0025 M002 :A F 105.2
0026      :JC =M003
0027      :S F 105.2
0028      :S F 105.7
0029      :L KH 0110
002B      :T QW 88
002C      :L KH 1000
002E      :T QW 90
002F      :BEU
0030      :
0031      :
0032 M003 :L KB 0
0033      :T FY 105
0034      :R Q 89.4
0035      :R Q 89.5
0036      :
0037      :BE
```

THIRD APPROACH SECTION: FORW.  
WITH LOW VELOCITY

IF THE REFERENCE POINT (LIMIT  
SWITCH END) HAS BEEN FOUND,  
RESET ALL AUXILIARY FLAGS  
AND SWITCH ON "STOP" MODE.

```

OB 1                                     LEN=63      ABS

SEGMENT 1      0000
0000          :
0001          :A  F  101.6      FLAG F 101.6 CAN BE SET
0002          :JC FB  50      IN THE WARM RESTART OBS,
0003 NAME     :PARAMETR      FOR EXAMPLE
0004          :
0005          :O  F  101.5      BOTH RECONFIGURATION MESSAGE
0006          :O  F  101.6      FRAMES CAN BE TRANSFERRED
0007          :R  F  101.5      DIRECT TO THE IP 267
0008          :BEC      WITH THIS BEC
0009          :
000A          :
000B          :A  I   0.0      ROUTINE FOR FIXED
000C          :S  F  101.0      POSITIONING JOBS
000D          :
000E          :      WITH FLAG F 103.7 THE PROGRAM
000F          :      WAITS FOR THE POSITIONING
0010          :A  F  103.7      JOB TO BE EXECUTED BEFORE
0011          :R  F  103.7      SWITCHING TO "NEUTRAL" MODE
0012          :BEC      (CPU WAIT CYCLE).
0013          :
0014          :A  F  101.0
0015          :JC FB  51
0016 NAME     :FEST-VP
0017          :
0018          :
0019          :A  I   0.1      ROUTINE FOR POSITIONING
001A          :S  F  101.1      JOBS WHICH CAN BE SET VIA
001B          :A  F  101.1      DIGITAL INPUTS
001C          :JC PB  52
001D          :
001E          :
001F          :A  F  104.7
0020          :R  F  104.7
0021          :BEC
0022          :
0023          :A  I   0.2      ROUTINE DETERMINING REFE-
0024          :S  F  104.6      RENCE POINT WITH SEPARATE
0025          :A  F  104.6      BERO
0026          :JC FB  53
0027 NAME     :RPKT
0028          :
0029          :A  F  105.7
002A          :R  F  105.7
002B          :BEC
002C          :
002D          :A  I   0.3      ROUTINE FOR DETERMINING
002E          :S  F  105.6      REFERENCE POINT WITH
002F          :A  F  105.6      LIMIT SWITCH END
0030          :JC FB  54
0031 NAME     :EPKT
0032          :
0033          :
0034          :
0035          :
0036          :      ... THEN USER PROGRAM ...
0037          :
0038          :
0039          :BE

```

## 6.6 Loading and Unloading a Waggon

In this example, a waggon travels from silo C to silos A and B one after the other and is loaded there, subsequently bringing the load back to silo C ( Figure 6-5.).

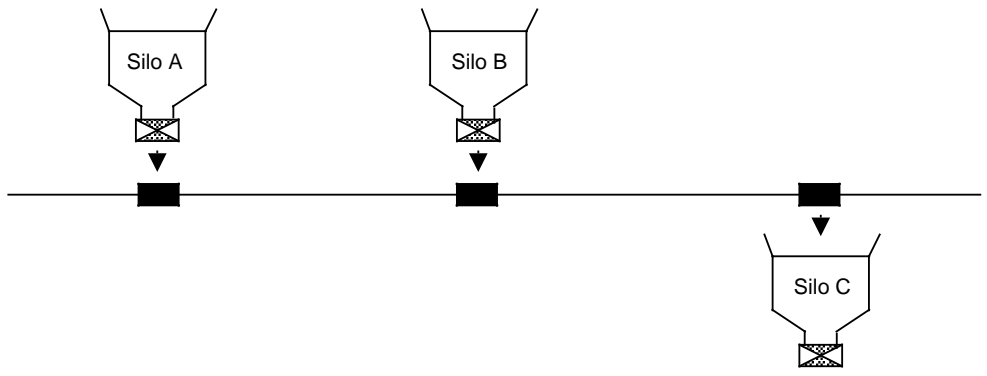

**Figure 6-5. Arrangement of the Silos Along the Path**

The path is divided into three sections and section C to A is to be traversed with increased velocity since the waggon travels this section unloaded ( Table 6-1.). Path resolution is fixed at 20  $\mu\text{m}/\text{pulse}$ .

**Table 6-1. Path Breakdown**

Subpath	A B	B C	C A
Paths	200 mm	400 mm	600 mm
Velocity	100 mm/s	100 mm/s	200 mm/s

### 6.6.1 Selecting the Motor

We have selected a spindle with a ratio of 4 mm (0.15 in.)/rev and a stepper motor with 200 pulses per revolution for the application illustrated.

The drive selected permits a maximum positioning range of:

$$1,048,575 \text{ pulses} * 20 \text{ } \mu\text{m/pulse} = 20,971,500 \text{ } \mu\text{m} \quad 21 \text{ m}$$

The positioning jobs can therefore be implemented with the drive selected.

Both positioning velocities correspond to the following stepping rates:

- 100 mm/s    25 revs/s    25 revs/s \* 200 pulses/rev = 5000 Hz
- 200 mm/s    50 revs/s    50 revs/s \* 200 pulses/rev = 10 kHz

The motor is to be used in full-step mode.

### 6.6.2 Setting the Configuration Data

Acceleration is to be increased during phase C to A in order to speed up the process. The IP 267 must therefore receive two configuration message frames in order to generate the different acceleration ramps. The following values must be calculated or determined for the configuration data:

- Limit switch configuration and "STOP" mode
- The base value BV for the stepping rate and the start/stop rate
- The multiplier for the start/stop rate (SS)
- The time interval for frequency increase/decrease (TI)

You will find the calculations in this order on the next page.

### 6.6.3 Configuration Data for the Path C to A

The configuration data is stored as 4-byte message frames in output bytes QB 88 to QB 91 of the PIQ. You should define the limit switch configuration first. The power section has been set to full-step mode, e.g by jumpers. You must set the "STOP" mode so that the configuration data is accepted by the IP 267. This data must be written into QB 89 of the PIQ as byte 1 ( Table 6-2.).

**The following applies for this example: QB 89 = 00000010 = 02<sub>H</sub>**

The base value (BV) for the stepping rate and the start/stop rate must then be calculated. Select as small a base value for both frequencies as possible so that you can set a discrete stepping rate and start/stop rate. However, the base value must be large enough to achieve the desired maximum stepping rate. Calculate the base value according to the following formula in order to achieve the stepping rate ( $f_A$ ) of 10 kHz:

$$\begin{aligned} f_A &= BV * G * R \\ 10\,000\text{ Hz} &= BV * 250 * 1 \\ BV &= 40\text{ Hz} \end{aligned}$$

V is the multiplier for the velocity and for R you can select the reduction factor 1 or 0.1.

The value calculated for BV is coded with bits FB 0 and FB 2 and written into QB 91 of the PIQ as byte 3 of the configuration message frame ( Table 6-2.).

**The following applies for this example: QB91 = 00000100 = 04<sub>H</sub>**

You must take account of the "Moment of inertia as a function of the permissible start/stop rate" curve in order to be able to configure the correct start/stop rate ( Figure 6-6.). For this purpose, you must take account of the moment of inertia of all moving parts in your drive (linear and rotary including the stepper motor rotor). The configured value for the start/stop rate must be in the lower part of the curve.

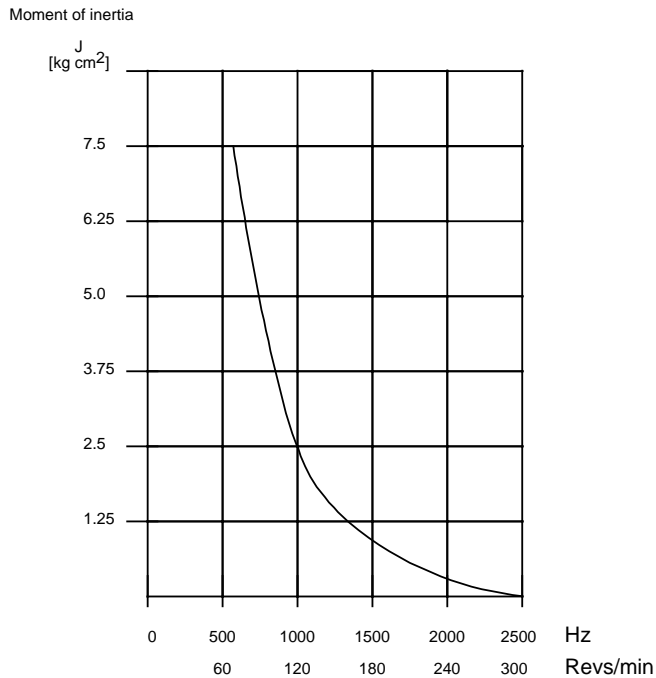

**Figure 6-6. Example of Moment of Inertia as a Function of  $f_{SS}$**

A start/stop rate of  $f_{SS} = 320$  Hz was selected for this example. The following therefore applies:

$$f_{SS} = BV * SS * R$$

$$320 \text{ Hz} = 40 * SS * 1$$

$$SS = 8$$

The value calculated for SS is coded with bits 0 to 7 of byte 0 of the configuration message frame and written into QB 88 of the PIQ ( Table 6-2.).

**The following applies for this example: QB 88 = 00001000 = 08<sub>H</sub>**



The suitable interval for frequency increase and decrease (TI) must be calculated specifically for each plant. The acceleration and deceleration values with which the motor can be driven without losing steps are to be found in the documentation of the motor manufacturer. The values depend on the moment of inertia of the drive and on the available torque of the motor ( 5.6). In this example, frequency increase and decrease is fixed at 50 Hz/ms. The following therefore applies for calculating the time interval:

$$a = \frac{BV * R}{4 * 0.032 \text{ ms} * TI}$$

$$50 \text{ Hz/ms} = \frac{40 * R}{4 * 0.032 \text{ ms} * TI}$$

$$TI = \frac{40 * 1}{4 * 0.032 \text{ ms} * 50 \text{ Hz/ms}}$$

$$TI = 6.25$$

The time interval may not be less than 7. This then corresponds to the following acceleration ramp:

$$a = \frac{BV * F}{4 * 0.032 \text{ ms} * TI}$$

$$a = \frac{40 * 1}{4 * 0.032 \text{ ms} * 7} = 44.6 \text{ Hz/ms}$$



The value of TI is coded with bits 0 to 7 of byte 2 and written into QB 90 of the PIQ ( Table 6-2.).

**The following applies for this example: QB 90 = 00000111 = 07<sub>H</sub>**

**Table 6-2. Configuration Message Frame for the Path C to A**

Byte	Address	General meaning	Configuration data for the path C to A
0	QB 88	Multiplier for the start/stop rate (SS), SS can assume values from 1 to 255	SS = 8 QB 88 = 00001000 QB 88 = 08 <sub>H</sub>
1	QB 89	Limit switch configuration "STOP" mode	EK = 1 BA1=0, BA0=0 QB 89 = 00000010 QB 89 = 02 <sub>H</sub>
2	QB 90	Time interval (TI) for frequency change TI can assume values from 1 to 255	TI = 7 QB 90 = 00000111 QB 90 = 07 <sub>H</sub>
3	QB 91	Base value (BV) for the frequency	BV = 40 QB 91 = 00000100 QB 91 = 04 <sub>H</sub>

## 6.6.4 Configuration Data for the Paths A to B and B to C

Limit switch configuration remains at "1" active, the motor continues to run in full-step mode and "STOP" mode instructs the IP 267 to transfer the data. Byte 1 of the new configuration message frame is transferred unchanged to output byte QB 89 of the PIQ ( Table 6-3.).

**The following applies for this example: QB 89 = 0000 0010 =02<sub>H</sub>**

The stepping rate  $f_A$  on the paths A to B and B to C is to be halved to 5 kHz in order to reduce the velocity of the loaded waggon. The new stepping rate is reached by halving the base value for the frequency (BV) from 40 to 20 Hz.

$$\begin{aligned} f_A &= BV * V * R \\ 5 \text{ kHz} &= BV * 250 * 1 \\ BV &= 20 \text{ Hz} \end{aligned}$$

The new value for BV is written into output byte QB 91 of the PIQ as byte 3 of the new configuration message frame. ( Table 6-3.).

**The following applies for this example: QB 91 = 0000 0101 =05<sub>H</sub>**

The start/stop rate  $f_{SS}$  for both paths is to be reduced to a maximum of 90 Hz. This compensates for the additional moment of inertia of the loads. The new multiplier for the start/stop rate (SS) is calculated with the following formula:

$$\begin{aligned} f_{SS} &= BV * SS * R \\ 90 \text{ Hz} &= 20 * SS * 1 \\ SS &= 4.5 \end{aligned}$$

SS = 4 has been selected in this example. This corresponds to a start/stop rate of 80 Hz.

The new value for SS is written into QB 88 of the PIQ as byte 0 of the configuration message frame ( Table 6-3.).

**The following applies in this example: QB 88 = 0000 0100 =04<sub>H</sub>**

Frequency change a (acceleration and deceleration) is reduced compared to the previous path section; a is to have a maximum value of 10 Hz/ms on paths A to B and B to C. The value for the time interval of the frequency change (TI) is calculated as follows:

$$a = \frac{BV * R}{4 * 0.032 \text{ ms} * TI}$$

$$TI = \frac{BV * R}{4 * 0.032 \text{ ms} * a}$$

$$TI = \frac{20 * 1}{4 * 0.032 \text{ ms} * 10 \text{ Hz/ms}}$$

$$TI = 15.625$$

So that the condition  $a < 10 \text{ Hz/ms}$  can be adhered to, TI must be  $> 15.625$ . TI=16 results in the following value for a:

$$a = \frac{BV * R}{4 * 0.032 \text{ ms} * 16}$$

$$a = \frac{20 * 1}{4 * 0.032 \text{ ms} * 16}$$

$$a = 9.76 \text{ Hz/ms}$$

The new value is written into QB 90 of the PIQ as byte 2 ( Table 6-3.).

The following applies for this example: QB 90 = 0001 0000 = 10<sub>H</sub>

**Table 6-3. Configuration Message Frame for the Paths A to B and B to C**

Byte	Address	General meaning	Configuration data for paths A to B and B to C
0	QB 88	Multiplier for the start/stop rate (SS), SS can assume values from 1 to 255	SS = 4 QB 88 = 0000 0100 QB 88 = 04 <sub>H</sub>
1	QB 89	Limit switch configuration "STOP" mode	EK = 1 BA1=0, BA0=0 QB 89 = 0000 0010 QB 89 = 02 <sub>H</sub>
2	QB 90	Time interval (TI) for frequency change TI can assume values from 1 to 255	TI = 16 QB 90 = 0001 0000 QB 90 = 10 <sub>H</sub>
3	QB 91	Base value (BV) for the frequency	BV = 20 QB 91 = 0000 0101 QB 91 = 05 <sub>H</sub>

### 6.6.5 Positioning Job C to A

The IP 267 is configured with the first data set for this job.

The path is 600 mm (23.6 in.). The following number of pulses is calculated for a given resolution of 20 μm/pulse:

$$\frac{600 \text{ mm}}{0.020 \text{ mm/pulse}} = 30\,000 \text{ pulses} = 7530_{\text{H}} \text{ pulses}$$

The velocity in this section is to be 200 mm (7.8 in.)/s which corresponds to the following stepping rate  $f_A$ :

$$f_A = \frac{200 \text{ mm/s}}{0.020 \text{ mm/pulse}} = 10 \text{ kHz}$$

The base value is set at 40 Hz from which the following velocity factor  $V$  is calculated:

$$\begin{aligned} 10\,000 \text{ Hz} &= BV * V * R \\ 10\,000 \text{ Hz} &= 40 * V * 1 \\ V &= 250 = FA_{\text{H}} \end{aligned}$$

Direction of travel "Backwards" is entered in the positioning job as the operating mode. The output message frame for the positioning job is represented in Table 6-4.

**Table 6-4 Positioning Job for the Path C to A**

Byte	Address	General meaning	Positioning data for path C to A
0	QB 88	Multiplier for the velocity (V), V can assume values from 1 to 255	V = 250 QB 88 = 1111 1010 QB 88 = FA <sub>H</sub>
1	QB 89	Reduction factor R = 1 Reference point approach (RPA) Operating mode OM 0, OM 1 Path P16 to P19	R=0, RF=0 BA1=1, BA0=0 QB 89 = 0010 0000 QB 89 = 20 <sub>H</sub>
2	QB 90	Path P8 to P15	QB 90 = 0111 0101 QB 90 = 75 <sub>H</sub>
3	QB 91	Path P0 to P7	QB 91 = 0011 0000 QB 91 = 30 <sub>H</sub>



### 6.6.6 Positioning Job A to B

The IP 267 is configured with the second data set for this job.

The path is 200 mm (7.8 in.). The following number of pulses is calculated for a given resolution of 20 μm/pulse:

$$\frac{200 \text{ mm}}{0.020 \text{ mm/pulses}} = 10\,000 \text{ pulses} = 2710_{\text{H}} \text{ pulses}$$

The velocity on this section is to be 100 mm (3.9 in.)/s which corresponds to the following stepping rate  $f_A$ :

$$f_A = \frac{100 \text{ mm/s}}{0.020 \text{ mm/pulse}} = 5 \text{ kHz}$$

The base value is set at 20 Hz from which the following velocity factor  $V$  is calculated:

$$5 \text{ kHz} = BV * V * R$$

$$5 \text{ kHz} = 20 * V * 1$$

$$V = 250 = FA_H$$

The direction of travel "Forwards" is entered in the positioning job as the operating mode. The positioning message for this job is represented in Table 6-5.

**Table 6-5. Positioning Job for the Path A to B**

Byte	Address	General meaning	Positioning data for path A to B
0	QB 88	Multiplier for the velocity ( $V$ ), $V$ can assume values from 1 to 255	$V = 250$ QB 88 = 1111 1010 QB 88 = $FA_H$
1	QB 89	Reduction factor $R = 1$ Reference point approach (RPA) Operating mode OM 0, OM 1 Path P16 to P19	$R = 0, RF = 0$ OM 1=0, OM 0=1 QB 89 = 0001 0000 QB 89 = $10_H$
2	QB 90	Path P8 to P15	QB 90 = 0010 0111 QB 90 = $27_H$
3	QB 91	Path P0 to P7	QB 91 = 0001 0000 QB 91 = $10_H$



### 6.6.7 Positioning Job B to C

This positioning job is the same as that for path A to B ( 6.6.6). You do not have to send new configuration data to the IP 267 for this job. The path in this job is double the length at 20,000 pulses (04E20<sub>H</sub>).

The output message frame contains the following values:

**Table 6-6. Positioning Job for Path B to C**

Byte	Address	General meaning	Positioning data for path B to C
0	QB 88	Multiplier for the velocity (V), V can assume values from 1 to 255	V = 250 QB 88 = 1111 1010 QB 88 = FA <sub>H</sub>
1	QB 89	Reduction factor R = 1 Reference point approach (RPA) Operating mode OM 0, OM 1 Path P16 to P19	R=0, RF=0 OM 1=0, OM 0=1 QB 89 = 0001 0000 QB 89 = 10 <sub>H</sub>
2	QB 90	Path P8 to P15	QB 90 = 0100 1110 QB 90 = 4E <sub>H</sub>
3	QB 91	Path P0 to P7	QB 91 = 0010 0000 QB 91 = 20 <sub>H</sub>

## 6.6.8 Linking to the User Program

The application illustrated in Chapter 6.6 corresponds to the program example 6.6.9. The user program has the following structure:

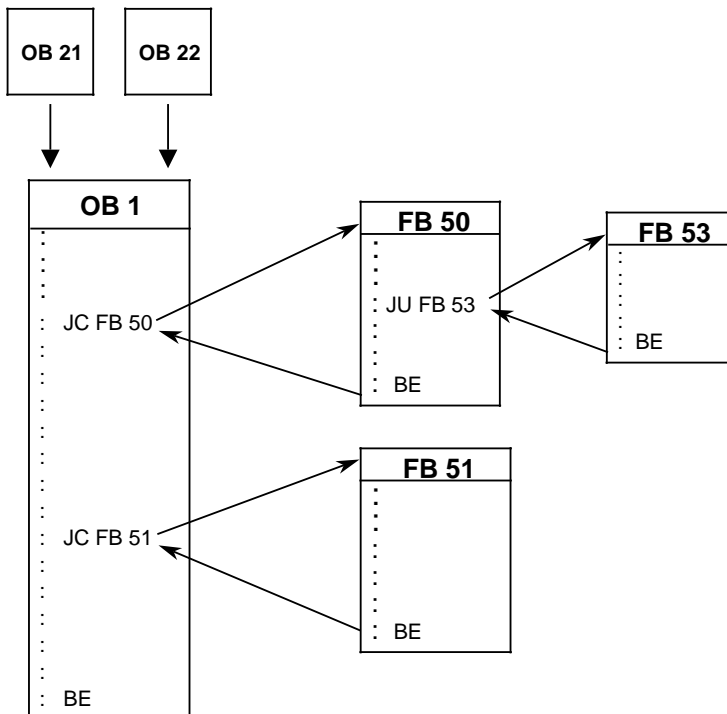

**Figure 6-7. Structure of the User Program "Loading and Unloading a Waggon"**

The IP 267 is configured with a new data set with FB 50. FB 53 then executes a reference point approach to point C. Point C is taken as the reference point in the example program.

Since the reference point is lost whenever the positioning program is interrupted, FB 50 must be called on all cold restarts or warm restarts of the CPU. OB 21 and OB 22 are used for this purpose: they prepare the conditional jump to FB 50.

The positioning program is then started by calling FB 51.

## 6.6.9 Program Example "Loading and Unloading a Waggon"

```

FB 50                               LEN=48       ABS
                                       PAGE 1
SEGMENT 1      0000
  
```

THE IP 267 CAN BE RECONFIGURED WITH DATA SET 2 USING FB50.  
 AN AUTOMATIC REFERENCE POINT APPROACH TO THE REFERENCE SWITCHING POINT IS THEN EXECUTED. THE REFERENCE SWITCHING POINT HAS BEEN SET TO C.

FB50 IS TO BE CALLED ON EACH WARM RESTART OF THE PC. FOR THIS REASON IT IS AUTOMATICALLY CALLED WITH FLAG F 101.6 AT EACH WARM RESTART (SEE OB 21-OB 22-OB 1). HOWEVER, IT CAN ALSO BE STARTED MANUALLY BY A POSITIVE EDGE AT INPUT I 0.7 (SEE OB 1).

CAUTION: IF INPUT I0.7 IS NOT RESET, REFERENCE POINT APPROACHES WILL BE EXECUTED ONE AFTER THE OTHER FOR AN UNSPECIFIED TIME!

NAME :PARAM-RP

```

0005      :A  F 101.7
0006      :JC =M001
0007      :
0008      :
0009      :S  F 101.7
000A      :L  KH 0000
000C      :T  QW 88
000D      :BEC
000E      :
000F      :
0010 M001 :A  F 105.0
0011      :JC =M002
0012      :
0013      :
0014      :S  F 105.0
0015      :L  KH 0402
0017      :T  QW 88
0018      :L  KH 1005
001A      :T  QW 90
001B      :BEC
001C      :
  
```

```

CONFIGURATION MESSAGE FRAME 2
---> FOR PATHS
      A-->B AND B-->C
  
```



```
001D M002 :JU FB 53
001E NAME :RPKT
001F      :
0020     :A  F  104.7
0021     :BEC
0022     :
0023     :A  F  101.4           F 101.4 = REF.POINT APPROACH COMPLETE
0024     :R  F  101.4
0025     :R  F  101.7           RESET ALL AUXILIARY FLAGS
0026     :R  F  101.6           IF THE REFERENCE POINT APPROACH
0027     :R  F  105.0           IS COMPLETE
0028     :
0029     :
002A     :BE
```

FB 51

LEN=111

ABS

SEGMENT 1 0000

THE FOLLOWING JOBS CAN BE PROCESSED ONE AFTER THE OTHER WITH FB51:

```

----> RECONFIGURING THE IP: LOADING OF CONFIGURATION MESSAGE FRAME 1
----> POSITIONING JOB FOR PATH C --> A
----> RECONFIGURING THE IP: LOADING OF CONFIGURATION MESSAGE FRAME 2
----> POSITIONING JOB FOR PATH A --> B
----> POSITIONING JOB FOR PATH B --> C

```

THE PROGRAM IS STARTED BY A POSITIVE EDGE AT I0.0 (SEE OBL).

**CAUTION:** THE TRAVERSING PROGRAM IS REPEATED UNTIL INPUT I0.0 IS RESET.

NAME :VPROG

```

0005      :
0006      :A  I  89.6          SWITCH ON "NEUTRAL" MODE
0007      :S  Q  89.4          AS SOON AS THE POSITIONING JOB
0008      :S  Q  89.5          IS EXECUTED
0009      :BEC
000A      :
000B      :
000C      :A  F 103.0
000D      :JC  =M001
000E      :S  F 103.0
000F      :S  F 103.7          RECONFIGURATION OF THE IP 267:
0012      :T  QW 88
0013      :BEU                  CONFIGURATION MESSAGE FRAME 1
0014      :
0015      :                    FOR PATH C --> A IS LOADED
0016      :
0017 M001 :A  F 103.1
0018      :JC  =M002
0019      :S  F 103.1
001A      :S  F 103.7
001B      :L  KH 0802
001D      :T  QW 88
001E      :L  KH 0704
0020      :T  QW 90
0021      :BEU
0022      :
0023      :

```

```
0024 M002 :A F 103.2
0025      :JC =M003
0026      :S F 103.2
0027      :S F 103.7
0028      :L KH FA20
002A      :T QW 88                POSITIONING JOB
002B      :L KH 7530            FOR PATH C --> A
002D      :T QW 90
002E      :BEU
002F      :
0030      :
0031 M003 :A F 103.3
0032      :JC =M004
0033      :S F 103.3
0034      :S F 103.7            RECONFIGURATION OF THE IP 267:
0035      :L KH 0000
0037      :T QW 88                CONFIGURATION MESSAGE FRAME 2
0038      :BEU
0039      :                FOR PATHS A --> B AND B --> C
003A      :
003B M004 :A F 103.4            IS LOADED
003C      :JC =M005
003D      :S F 103.4
003E      :S F 103.7
003F      :L KH 0402
0041      :T QW 88
0042      :L KH 1005
0044      :T QW 90
0045      :BEU
0046      :
0047      :
0048 M005 :A F 103.5
0049      :JC =M006
004A      :S F 103.5
004B      :S F 103.7
004C      :L KH FA10
004E      :T QW 88                POSITIONING JOB
004F      :L KH 2710            FOR PATH A --> B
0051      :T QW 90
0052      :BEU
0053      :
0054      :
```

```

0055 M006 :A F 103.6
0056      :JC =M007
0057      :S F 103.6
0058      :S F 103.7
0059      :L KH FA10
005B      :T QW 88
005C      :L KH 4E20
005E      :T QW 90
005F      :BEU
0060      :
0061      :
0062 M007 :R F 101.0
0063      :R Q 89.4
0064      :R Q 89.5
0065      :L KB 0
0066      :T FY 3
0067      :
0068      :
0069      :BE

```

POSITIONING JOB  
FOR PATH B --> C

RESET THE AUXILIARY FLAG PARAMETERS  
AND SWITCH ON THE "STOP" MODE  
AT THE END OF THE TRAVERSING PROGRAM  
CONTAINED IN FB51

**FB 53**

LEN=82

ABS

```

SEGMENT 1      0000
NAME          :RPKT

0005          :A E 88.5
0006          :S Q 89.4
0007          :S Q 89.5
0008          :BEC
0009          :
000A          :
000B          :A F 104.0
000C          :JC =M001
000D          :S F 104.0
000E          :S F 104.7
000F          :L KH 585F
0011          :T QW 88
0012          :L KH FFFF
0014          :T QW 90
0015          :BEU
0016          :
0017          :
0018 M001 :AN F 104.1
0019          :A E 88.1
001A          :S F 104.1
001B          :JC =M002
001C          :

```

IF PULSES ARE OUTPUT, SWITCH ON  
"NEUTRAL" MODE AND DO NOT PROCESS THE  
FB.

FIRST APPROACH SECTION: FORWARDS,  
WITH REFERENCE POINT BIT SET AND  
MAXIMUM PATH

IF THE BERO HAS BEEN DETECTED IN THE  
FIRST APPROACH SECTION, SKIP THE  
SECOND SECTION

```

001D      :
001E      :A   F  104.1
001F      :JC  =M002
0020      :S   F  104.1
0021      :S   F  104.7
0022      :L   KH 586F
0024      :T   QW  88
0025      :L   KH FFFF
0027      :T   QW  90
0028      :BEU
0029      :
002A      :
002B M002 :A   F  104.2
002C      :JC  =M003
002D      :S   F  104.2
002E      :S   F  104.7
002F      :L   KH 2820
0031      :T   QW  88
0032      :L   KH 0300
0034      :T   QW  90
0035      :BEU
0036      :
0037      :
0038 M003 :A   F  104.3
0039      :JC  =M004
003A      :S   F  104.3
003B      :S   F  104.7
003C      :L   KH 0150
003E      :T   QW  88
003F      :L   KH 4000
0041      :T   QW  90
0042      :BEU
0043      :
0044      :
0045 M004 :L   KB  0
0046      :T   PB 104
0047      :S   F  101.4
0048      :R   Q   89.4
0049      :R   Q   89.5
004A      :R   Q   89.6
004B      :
004C      :BE

```

SECOND APPROACH SECTION: BACKWARDS  
WITH REFERENCE POINT BIT SET AND  
MAXIMUM PATH

AUXILIARY APPROACH SECTION BACKWARDS,  
WITHOUT REFERENCE POINT BIT TO MAKE  
SURE THE DRIVE IS NO LONGER AT THE  
BERO. THE PATH MUST THEREFORE BE  
ADJUSTED TO THE DRIVE.

THIRD APPROACH SECTION: FORWARDS  
WITH REFERENCE POINT BIT SET AND  
LOW VELOCITY

WHEN THE REFERENCE POINT APPROACH IS  
COMPLETED, RESET ALL AUXILIARY FLAGS  
AND SWITCH ON "STOP" MODE



```

OB 1                                     LEN=40      ABS
                                           PAGE 1

SEGMENT 1      0000
0000          :A  I   0.7                FLAG F 101.6 CAN ALSO BE SET
0001          :S  F  101.6              IN THE WARM RESTART OBS
0002          :
0003          :A  F  104.7
0004          :R  F  104.7
0005          :BEC
0006          :
0007          :A  F  101.6              "BASIC STATUS" ROUTINE
0008          :JC  FB  50                OF THE IP 267 ON WARM RESTART
0009 NAME     :PARAM-RP
000A          :
000B          :O  F  104.7
000C          :O  F  101.6
000D          :BEC
000E          :
000F          :
0010          :
0011          :
0012          :
0013          :A  I   0.0                ROUTINE FOR STARTING
0014          :S  F  101.0              THE USER PROGRAM
0015          :
0016          :
0017          :A  F  103.7              WITH FLAG F 103.7 THE PROGRAM WAITS
0018          :R  F  103.7              FOR THE POSITIONING JOB
0019          :BEC                       TO BE EXECUTED
001A          :                          BEFORE SWITCHING TO "NEUTRAL" MODE
001B          :A  F  101.0              (CPU WAIT CYCLE)
001C          :JC  FB  51
001D NAME     :VPROG
001E          :
001F          :
0020          :
0021          :
0022          :BE

```

OB 21

LEN=16

ABS

PAGE 1

```
SEGMENT 1      0000
0000      :AN  F  101.6
0001      :S   F  101.6
0002      :
0003      :L   KF +0
0005      :T   FW  103
0006      :
0007      :U   F  101.0
0008      :R   F  101.0
0009      :
000A      :BE
```

OB 22

LEN=16

ABS

PAGE 1

```
SEGMENT 1      0000
0000      :AN  F  101.6
0001      :S   F  101.6
0002      :
0003      :L   KF +0
0005      :T   FW  103
0006      :
0007      :U   F  101.0
0008      :R   F  101.0
0009      :
000A      :BE
```

<b>7</b>	<b>Funktion block for assigning parameters to the IP 267</b>	
7.1	Structure of the program example .....	7 - 1
7.2	Structure of function block 17 .....	7 - 2
7.3	User program for positioning .....	7 - 9
7.4	Description of the user data block.....	7 - 17
7.5	Calling function block 17 .....	7 - 23

## 7 Funktion block for assigning parameters to the IP 267

### 7.1 Structure of the program example

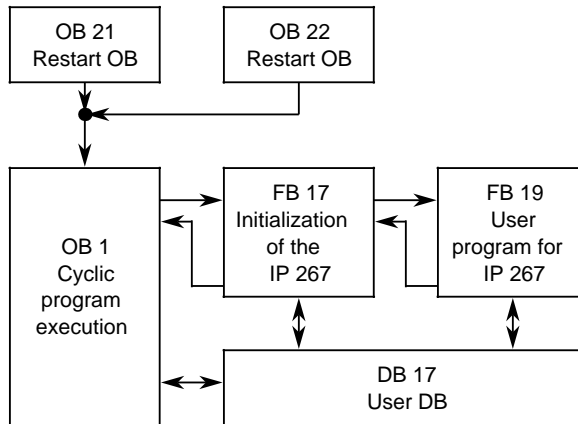

#### Data exchange:

OB 1 - DB 17: Store feedback message frame from PI1  
Transfer positioning or configuration message frame into PIQ

FB 17 - DB 17: Load feedback message frame and parameters from DB  
Transfer feedback message frame after processing to DB  
Transfer positioning or configuration message frame after processing to DB

FB 19 - DB 17: Transfer parameters to DB for positioning or configuring

Flag and data areas used in the function blocks:

Flag words:	FW 100 to FW 106	-	FB 17
	FW 110	-	FB 19
Data words:	DW 0 to DW 23	-	DB 17

7

### **Application of function block FB 17**

This function block supports operator communication and visualization using the IP 267 stepper motor controller in conjunction with the CPU 102 (from 6ES5 102 - 8MA02 onwards) or CPU 103.

To facilitate configuring and positioning, the various parameters can be transferred to different data words of the user data block. The function block has access to this data area and converts the parameters to the required 4-byte format.

Additionally, the traversing path (linear axis) or the angle of rotation (rotary axis) can be entered directly and the residual distance or angle read. This relieves the user of having to convert the distance (angle) to go into the corresponding number of pulses, and vice versa.

### **General note on communications**

As the PII and PIQ are updated simultaneously, the feedback messages are delayed by one OB 1 cycle. To avoid undesirable reactions of the user program to the "old" data, the positioning functions and the output of new positioning or configuration message frames must be deactivated in the user program for every second OB 1 cycle.

## **7.2 Structure of function block 17**

### **General**

Communication between the CPU and the IP 267 is limited to three different types of message frame:

- Configuration message frames
- Positioning message frames
- Feedback message frames.

The FB 17 includes one separate segment for each type of message frame and an additional one for calling the user program.

- Segment 1 - Read feedback message frame
- Segment 2 - Calling user program
- Segment 3 - Transmit configuration message frame
- Segment 4 - Transmit positioning message frame

IP 267 \_\_\_\_\_ Function block for assigning parameters to the IP 267

The user program must be called in segment 2 to enable a fast response to current feedback messages from the IP.

FB 17 Segment 1

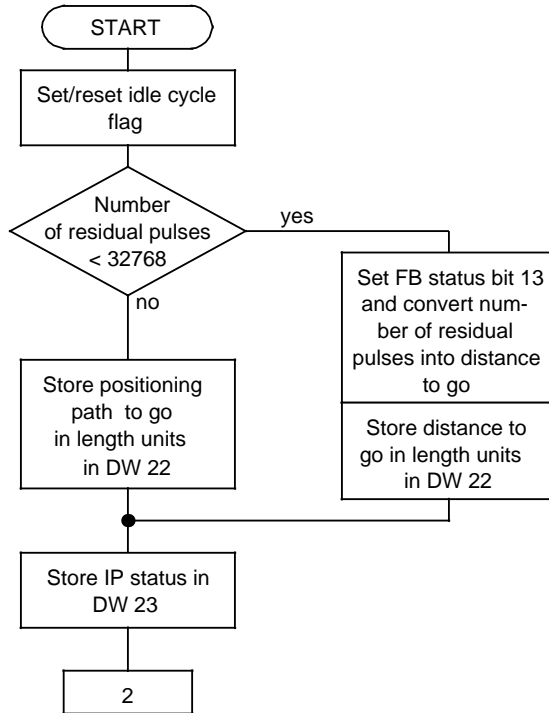

FB 17 Segment 2

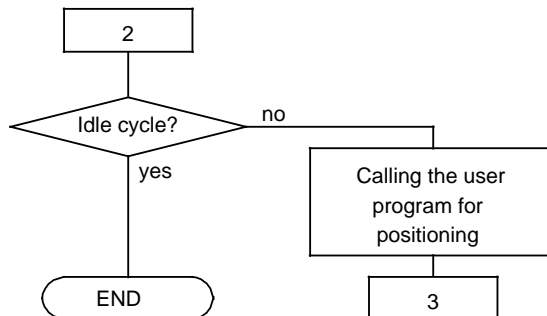

FB 17 Segment 3

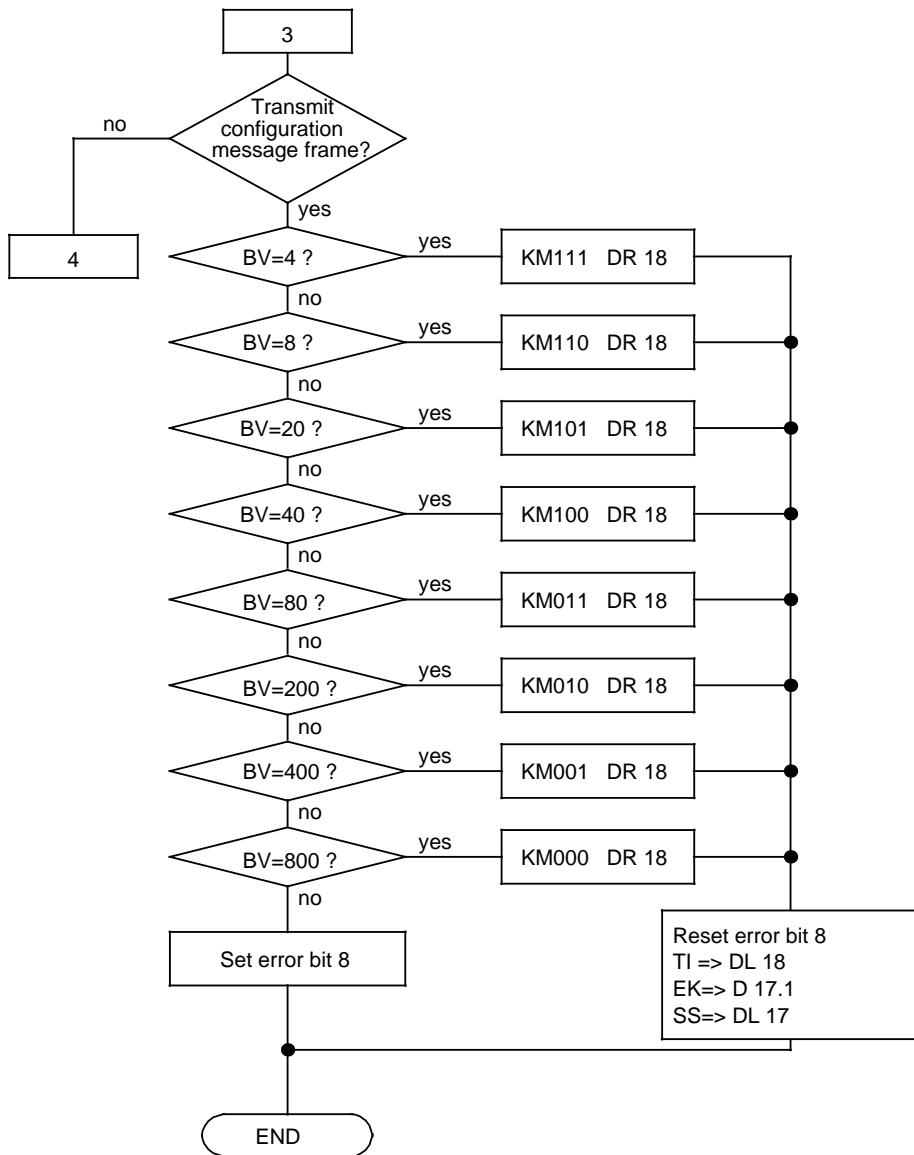

FB 17 Segment 4

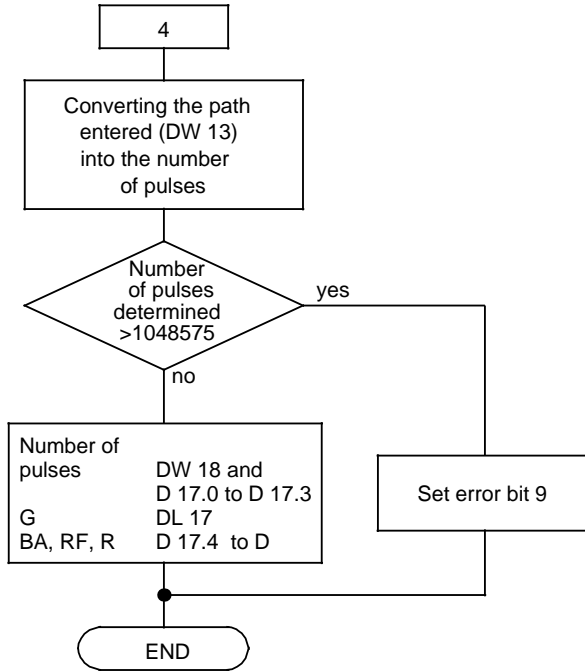



Function block for assigning parameters to the IP 267 \_\_\_\_\_ IP 267

FB 17

LAE=157

NAME :IP-OP

```

0005      :AN  F  100.4      AUXILIARY FLAG FOR IDLE CYCLE
0006      :=   F  100.4
0007      :L   DW  15        DISTANCE TO GO IS SMALLER
0008      :SLW      12      THAN 16 BITS ?
0009      :L   DW  16
000A      :SRW      15
000B      :OW
000C      :L   KF  +0
000E      :!=F
000F      :=   F  100.5
0010      :L   DW  13
0011      :T   DW  22        NO :TOTAL PATH AS
0012      :JC  FB  243      FEEDBACK MESSAGE
0013 NAME :DIV:16
0014 Z1   :   DW  16
0015 Z2   :   DW  8        YES:CONVERTING NUMBER OF RESIDU-
0016 OV   :   F  101.0      AL PULSES INTO DISTANCE TO GO
0017 FEH  :   F  101.1
0018 Z3=0 :   F  101.2
0019 Z4=0 :   F  101.3
001A Z3   :   DW  22
001B Z4   :   FW  102
001C      :L   DW  15
001D      :SRW      6        STORE IP STATUS
001E      :T   DW  23
001F      :T   FW  104
0020      :***

```

```

SEGMENT 2      0021      USER PROGRAM SEGMENT
0021      :AN  F  100.4      IDLE CYCLE
0022      :L   FW  100      STORE FB STATUS
0023      :T   DW  20
0024      :BEC
0025      :JU  FB  19
0026 NAME :ABL.KET
0027      :***

```

IP 267 \_\_\_\_\_ Function block for assigning parameters to the IP 267

SEGMENT 3	0028	CONFIGURATION SEGMENT
0028	:L DW 1	
0029	:T FW 106	CONFIGURING/POSITIONING ?
002A	:A F 107.0	POSITIONING ?
002B	:JC =M001	
002C	:L DW 3	BASE VALUE = 4 ?
002D	:L KF +4	
002F	:><F	
0030	:JC =M002	
0031	:L KF +7	YES : KM 111 -> BYTE 3
0033	:JU =M003	
0034 M002	:L DW 3	BASE VALUE = 8 ?
0035	:L KF +8	
0037	:><F	
0038	:JC =M004	
0039	:L KF +6	YES : KM 110 -> BYTE 3
003B	:JU =M003	
003C M004	:L DW 3	BASE VALUE = 20 ?
003D	:L KF +20	
003F	:><F	
0040	:JC =M005	
0041	:L KF +5	YES : KM 101 -> BYTE 3
0043	:JU =M003	
0044 M005	:L DW 3	BASE VALUE = 40 ?
0045	:L KF +40	
0047	:><F	
0048	:JC =M006	
0049	:L KF +4	YES : KM 100 -> BYTE 3
004B	:JU =M003	
004C M006	:L DW 3	BASE VALUE = 80 ?
004D	:L KF +80	
004F	:><F	
0050	:JC =M007	
0051	:L KF +3	YES : KM 011 -> BYTE 3
0053	:JU =M003	
0054 M007	:L DW 3	BASE VALUE = 200 ?
0055	:L KF +200	
0057	:><F	
0058	:JC =M008	



Function block for assigning parameters to the IP 267 \_\_\_\_\_ IP 267

```

0059      :L   KF +2                YES :  KM 010  ->  BYTE 3
005B      :JU  =M003
005C M008 :L   DW   3                BASE VALUE = 400 ?
005D      :L   KF +400
005F      :><F
0060      :JC  =M009
0061      :L   KF +1                YES :  KM 001  ->  BYTE 3
0063      :JU  =M003
0064 M009 :L   DW   3                BASE VALUE = 800 ?
0065      :L   KF +800
0067      :><F
0068      :JC  =M010
0069      :L   KF +0                YES :  KM 000  ->  BYTE 3
006B      :JU  =M003
006C M010 :S   F 100.0              ERROR NO.1 : BV ILLEGAL
006D      :L   FW 100                STORE FB STATUS
006E      :T   DW  20
006F      :BEU
0070 M003 :R   F 100.0
0071      :T   DR  18                BASE VALUE          ->  BYTE 3
0072      :L   DR   5
0073      :T   DL  18                TIME INTERVAL      ->  BYTE 2
0074      :L   DW   6
0075      :SLW   15
0076      :SRW   14
0077      :T   DR  17                LIMIT SWITCH CON.  ->  BYTE 1
0078      :L   DR   4
0079      :T   DL  17                FACTOR SS-RATE     ->  BYTE 0
007A      :L   FW 100
007B      :T   DW  20                STORE FB STATUS
007C      :BEU
007D M001 :***

```

```

SEGMENT 4      007E      POSITIONING SEGMENT
007E      :JU  FB 242
007F NAME :MUL:16
0080 Z1   :   DW 13      CONVERTING THE PATH
0081 Z2   :   DW 8       INTO NUMBER OF PULSES
0082 Z3=0 :   F 101.4
0083 Z32  :   DW 17
0084 Z31  :   DW 18
0085      :L  DW 17      NUMBER OF PULSES PER AREA
0086      :L  KF +15     <= 20 BITS ?
0088      :>F
0089      :=  F 100.1    NO : ERROR NO. 2
008A      :L  FW 100
008B      :T  DW 20
008C      :BEC
008D      :L  DW 11      YES : REDUCTION FACTOR AND
008E      :SLW 7
008F      :L  DW 12      OPERATING MODE AND
0090      :SLW 4
0091      :OW           NUMBER OF PULSES
                        HIGH-WORD
0092      :L  DW 17
0093      :OW           ->  BYTE 0 AND 1
0094      :T  DW 17
0095      :L  DW 10      VELOCITY FACTOR
0096      :T  DL 17     ->  BYTE 0
0097      :BE

```



### 7.3 User program for positioning

The following program example shall illustrate the basic structure of a possible sequencer taking into account various start conditions (timer or pulse-triggered) of a positioning function. Note that the order in which the jobs are processed is determined by the step flags. The start conditions are only effective after the preceding job has been executed.

The program example is based on the following data:

```

Motor data : 200 pulses/rev.
Axis data  : 1 mm/rev.
Resolution : 200 pulses/mm

```

### Processing sequence

FB 19 Segment 1

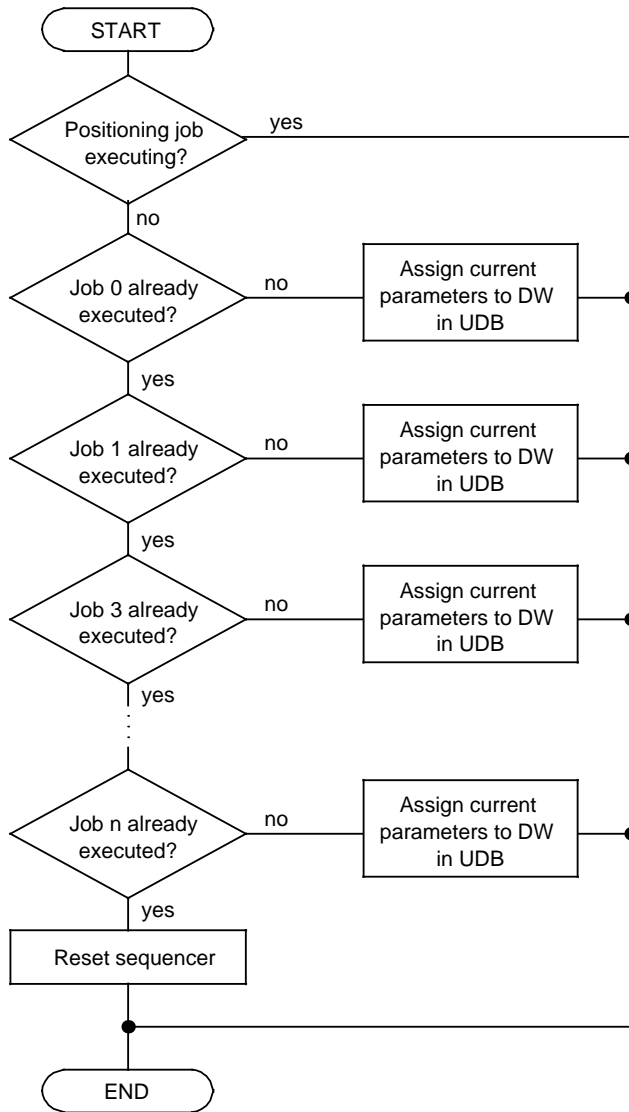

### Notes on the job execution

- Start new positioning job immediately after terminating the previous one  
Execution of this job depends on two conditions:

1. No pulses output by the IP
2. Job has not yet been executed.

For examples see: Jobs 0, 1, 2

- Start new positioning job on expiration of a set time  
Execution of this job depends on three conditions:

1. No pulses output by the IP
2. Job has not yet been executed
3. Expiration of set time.

For examples see: Jobs 3, 4

- Positioning job initiated by binary signal  
Execution of this job depends on three conditions:

1. No pulses output by the IP
2. Job has not yet been executed
3. Change of state of a binary operand

For examples see: Jobs 5, 6

- Disabling various jobs

For disabling individual jobs, the relevant step flags must be set.

For examples see: Jobs 7, 8, 9, 10, 11, 12

In the restart OBs, the step flags are set to ensure that the configuration is deleted, a new configuration transferred and a reference point approach started before processing of the sequencer begins.

Function block for assigning parameters to the IP 267 \_\_\_\_\_ IP 267

FB 19

LAE=258

NAME :SEQCER

0005 :\*\*\*

SEGMENT 2

0006

0006	:A	F	105.7	POSITIONING JOB EXECUTING ?
0007	:BEC			YES : ABORT
0008	:A	F	110.0	STEP FLAG FOR JOB 0
0009	:JC	=A01		
000A	:S	F	110.0	JOB 0:
000B	:L	KF	+1	
000D	:T	DW	1	NEUTRAL
000E	:L	KF	+3	
0010	:T	DW	12	
0011	:BEU			
0012	A01	:A	F 110.1	STEP FLAG FOR JOB 1
0013	:JC	=A02		
0014	:S	F	110.1	
0015	:L	KF	+1	JOB 1 :
0017	:T	DW	1	
0018	:L	KF	+10	IDENTIFIER FOR POSITIONING
001A	:T	DW	10	
001B	:L	KF	+0	VELOCITY FACTOR : 10
001D	:T	DW	11	REDUCTION FACTOR: 1
001E	:L	KF	+1	OPERATING MODE : FORWARDS
0020	:T	DW	12	PATH [LU] : 100mm
0021	:L	KF	+100	
0023	:T	DW	13	
0024	:BEU			
0025	A02	:A	F 110.2	STEP FLAG FOR JOB 2
0026	:JC	=A03		
0027	:S	F	110.2	
0028	:L	KF	+20	
002A	:T	DW	10	JOB 2 :
002B	:L	KF	+0	
002D	:T	DW	11	VELOCITY FACTOR : 20
002E	:L	KF	+2	REDUCTION FACTOR : 1
0030	:T	DW	12	OPERATING MODE : BACKWARDS

IP 267 \_\_\_\_\_ Function block for assigning parameters to the IP 267

```

0031      :L  KF +200                PATH [LU] :                200mm
0033      :T  DW  13
0034      :BEU
0035 A03   :A  F  110.3              STEP FLAG FOR JOB 3
0036      :JC  =A04
0037      :L  KT  050.1              JOB 3 :
0039      :SD  T   10
003A      :AN  T   10                WAITING TIME   :                5.0 s
003B      :BEC
003C      :S  F  110.3
003D      :AN  T   10
003E      :SD  T   10
003F      :L  KF +50
0041      :T  DW  10                VELOCITY FACTOR :                50
0042      :L  KF +1                 REDUCTION FACTOR:                0.1
0044      :T  DW  11                OPERATING MODE  :                FORWARDS
0045      :L  KF +1                 PATH [LU]      :                500mm
0047      :T  DW  12
0048      :L  KF +500
004A      :T  DW  13
004B      :BEU
004C A04   :A  F  110.4              STEP FLAG FOR JOB 4
004D      :JC  =A05
004E      :L  KT  025.1              JOB 4 :
0050      :SD  T   11
0051      :AN  T   11                WAITING TIME   :                2.5 s
0052      :BEC
0053      :S  F  110.4
0054      :AN  T   11
0055      :SD  T   11
0056      :L  KF +100
0058      :T  DW  10                VELOCITY FACTOR :                100
0059      :L  KF +1                 REDUCTION FACTOR:                0.1
005B      :T  DW  11                OPERATING MODE  :                BACKWARDS
005C      :L  KF +2                 PATH [LU]      :                1000mm
005E      :T  DW  12
005F      :L  KF +1000
0061      :T  DW  13
0062      :BEU
0063 A05   :A  F  110.5              STEP FLAG FOR JOB 5

```





Function block for assigning parameters to the IP 267 \_\_\_\_\_ IP 267

```

0064      :JC  =A06
0065      :AN  I    3.0          JOB 5 :
0066      :BEC
0067      :S   F   110.5        START SIGNAL   :   INPUT 3.0
0068      :L   KF  +20
006A      :T   DW   10          VELOCITY FACTOR :           20
006B      :L   KF  +0          REDUCTION FACTOR:           1
006D      :T   DW   11          OPERATING MODE  :   FORWARDS
006E      :L   KF  +1          PATH [LU]           :           250mm
0070      :T   DW   12
0071      :L   KF  +250
0073      :T   DW   13
0074      :BEU
0075 A06  :A   F   110.6        STEP FLAG FOR JOB 6
0076      :JC  =A07
0077      :AN  I    3.1          JOB 6 :
0078      :BEC
0079      :S   F   110.6        START SIGNAL   :   INPUT 3.1
007A      :L   KF  +40
007C      :T   DW   10          VELOCITY FACTOR :           40
007D      :L   KF  +0          REDUCTION FACTOR:           1
007F      :T   DW   11          OPERATING MODE  :   BACKWARDS
0080      :L   KF  +2          PATH [LU]           :           100mm
0082      :T   DW   12
0083      :L   KF  +100
0085      :T   DW   13
0086      :BEU
0087 A07  :A   I    3.2          IF INPUT 3.2 ACTIVE,
0088      :S   F   110.7        JOBS 7 TO 10
0089      :S   F   111.0        ARE NOT PROCESSED !
008A      :S   F   111.1
008B      :S   F   111.2
008C      :A   F   110.7        STEP FLAG FOR JOB 7
008D      :JC  =A08
008E      :S   F   110.7        JOB 7 :
008F      :L   KF  +0
0091      :T   DW   10          DELETE CONFIGURATION
0092      :T   DW   12
0093      :BEU
0094 A08  :A   F   111.0        STEP FLAG FOR JOB 8

```

IP 267 \_\_\_\_\_ Function block for assigning parameters to the IP 267

```

0095      :JC  =A09
0096      :S   F 111.0          JOB 8 :
0097      :L   KF +0
0099      :T   DW  1          RECONFIGURATION
009A      :L   KF +80
009C      :T   DW  3          IDENTIFIER FOR CONFIGURATION
009D      :L   KF +20         BASE VALUE           : 80
009F      :T   DW  4          FACTOR FOR SS-RATE        : 20
00A0      :L   KF +30         TIME INTERVAL           : 30
00A2      :T   DW  5          LIMIT SWITCH CONFIG.     : 1
00A3      :L   KF +1
00A5      :T   DW  6
00A6      :BEU
00A7 A09  :A   F 111.1          STEP FLAG FOR JOB 9
00A8      :JC  =A10          JOBS 9 TO 12 REF. POINT APPR.
00A9      :S   F 111.1          JOB 9 :
00AA      :L   KF +1
00AC      :T   DW  1          APPROACH LIMIT SWITCH
00AD      :L   KF +80
00AF      :T   DW 10          VELOCITY FACTOR :           80
00B0      :L   KF +0          REDUCTION FACTOR:           1
00B2      :T   DW 11          OPERATING MODE  : BACKWARDS
00B3      :L   KF +2          PATH [LU]           : MAX=5242mm
00B5      :T   DW 12
00B6      :L   KF +5242       (HERE MAX.PATH)
00B8      :T   DW 13
00B9      :BEU
00BA A10  :A   F 111.2          STEP FLAG FOR JOB 10
00BB      :JC  =A11
00BC      :S   F 111.2          JOB 10 :
00BD      :L   KF +1
00BF      :T   DW  1          REFERENCE POINT APPROACH
00C0      :L   KF +80
00C2      :T   DW 10          VELOCITY FACTOR :           80
00C3      :L   KF +0          REDUCTION FACTOR:           1
00C5      :T   DW 11          OPERATING MODE  : RPA FORW.
00C6      :L   KF +5          PATH [LU]           : MAX=5242mm
00C8      :T   DW 12
00C9      :L   KF +5242
00CB      :T   DW 13

```

```

00CC      :BEU
00CD A11  :A   F 111.3          STEP FLAG FOR JOB 11
00CE      :JC  =A12
00CF      :S   F 111.3          JOB 11 :
00D0      :L   KF +1
00D2      :T   DW  1          MOVE BACKW. FROM REF. POINT
00D3      :L   KF +80
00D5      :T   DW 10          VELOCITY FACTOR :          80
00D6      :L   KF +0          REDUCTION FACTOR:          1
00D8      :T   DW 11          OPERATING MODE  :  BACKWARDS
00D9      :L   KF +2          PATH [LU]      :          20mm
00DB      :T   DW 12
00DC      :L   KF +30
00DE      :T   DW 13
00DF      :BEU
00E0 A12  :A   F 111.4          STEP FLAG FOR JOB 12
00E1      :JC  =A13
00E2      :S   F 111.4          JOB 12 :
00E3      :L   KF +1
00E5      :T   DW  1          SET REFERENCE POINT
00E6      :L   KF +1
00E8      :T   DW 10          VELOCITY FACTOR :          1
00E9      :L   KF +0          REDUCTION FACTOR:          1
00EB      :T   DW 11          OPERATING MODE  :  RPA FORW.
00EC      :L   KF +5          PATH [LU]      :  MAX=5242mm
00EE      :T   DW 12
00EF      :L   KF +5242
00F1      :T   DW 13
00F2      :BEU
00F3 A13  :L   FW 110          END OF SEQUENCER REACHED ?
00F4      :L   KH FF1F
00F6      :><F
00F7      :BEC                NO --> CONTINUE
00F8      :L   KH 0000
00FA      :T   FW 110          YES --> SET STEP FLAG TO ZERO
00FB      :***

SEGMENT 3      00FC
00FC      :BE

```

## 7.4 Description of the user data block

- DW 0 - Unassigned
- DW 1 - K/P - Used for selecting the parameters to be transferred
- K/P = 0      Configuring  
                 Parameters : SS, EK, ZI, BW
- K/P = 1      Positioning  
                 Parameters : G, R, RF, BA, WS
- DW 2 - Unassigned
- DW 3 - BV - The eight frequency ranges that can be used for the base value must be entered in decimal form. In the case of an incorrect entry, an error bit is set (D 20.8) and the configuration discontinued (see Chapter 4.1.5).
- DW 4 - SS - Multiplier for start/stop rate (see Chapter 4.1.2)
- DW 5 - TI - Time interval for rate increase and decrease (see Chapter 4.1.4)
- DW 6 - EK - Limit switch configuration
- EK = 0 EPLUS, EMINUS, STOP : NC contact
- EK = 1 EPLUS, EMINUS, STOP : NO contact  
(see Chapter 4.1.3)
- DW 7 - Unassigned

- DW 8 - AL - This value describes the required plant sections (stepper motor, gears, leadscrew pitch). The user determines this value by dividing the number of pulses per revolution of the motor by the path (or angle) per revolution of the motor. The ratio of any gearing used must be taken into account.

e.g. linear axis :

Motor data	:	200 pulses/rev.
Axis data	:	1.0 mm/rev.
Resolution (Res.)	:	200 pulses/mm

In this case, the length is measured in mm. The minimum traversing path of a positioning job is therefore 1 mm. The maximum traversing path is the maximum number of pulses divided by the resolution (up to 32767 length units or angular units).

Max. numb. of pulses	:	1,048,575 pulses (20 bits)
Resolution	:	200 pulses/mm
Max. path	:	5242 mm

Many applications demand a higher positioning accuracy, which can be achieved by multiplying the parameter Res. several times by the factor 0.1. In the example above, the user may also enter 20 or 2, instead of 200, for the parameter Res.

The positioning accuracy thus changes from 1 mm to 100  $\mu\text{m}$  or 10  $\mu\text{m}$ ; consequently, the maximum traversing path is reduced from 5242 mm to 3276.7 mm or 327.67 mm. Additionally, the length unit [mm] assigned to the path in DW 13 changes to 100  $\mu\text{m}$  or 10  $\mu\text{m}$ .

If the resolution value is no integer value, a gearing with a suitable ratio should be selected to ensure that the maximum traversing path (angle of rotation) will not exceed the permissible limits.

e.g. rotary axis

Motor data	:	200	pulses/rev.
Axis data	:	360	deg/rev.
Resolution	:	0.55555	or 5/9

In this example, the smallest possible angle of rotation is 9 degrees, the resolution parameter is 5.

A better resolution can be achieved by dividing a circle up into gons and the use of only one gearing:

Motor data	:	200	pulses/rev.
Gearing	:	10	: 1
Axis data	:	400	deg/rev.
Resolution	:	5	pulses/deg

These specifications result in a minimum angle of one gon.

The length unit or angular unit selected by the user in connection with the resolution parameter is referred to the path (DW 13) and one positioning command.

- DW 9 - Unassigned
- DW 10 - G - Multiplier for the velocity (see Chapter 4.2.2)
- DW 11 - R - Reduction factor (see Chapter 4.2.3)

R = 0 Reduction factor = 1.0  
R = 1 Reduction factor = 0.1



- DW 12 - OM - Operating mode (see Chapter 4.2.3)
- OM = 0 Stop
  - OM = 1 Start forwards
  - OM = 2 Start backwards
  - OM = 3 Neutral
  - OM = 5 Start forwards + reference point
  - OM = 6 Start backwards + reference point
- DW 13 - WS - The path must be entered in the length unit or angular unit selected by the user in DW 8 (resolution).  
Input range: 0 to 32767 (cf. DW 8 - resolution parameter)
- DW 14 - Unassigned
- DW 15 - IW0 - Byte 0 and byte 1 - Data from IP
- DW 16 - IW1 - Byte 2 and byte 3 - Data from IP
- These two data words must be assigned by the user before calling the FB 17 from the PII.
- DW 17 - QW0 - Byte 0 and byte 1 - Data to IP
- DW 18 - QW1 - Byte 2 and byte 3 - Data to IP
- These two data words must be transferred by the user to the PIQ after calling the FB 17.
- DW 19 - Unassigned

- DW 20 - FB - FB status and error messages
- Structure: DR - Auxiliary flag area for internal conversions.  
DL - Error messages and FB status
- D 20.8 =1 - Base value entered incorrectly
- D 20.9 =1 - Calculated number of pulses exceeds 20 bit range
- D 20.12 =1 - Network for configuring or positioning is being processed  
=0 - Idle cycle
- D 20.13 =1 - Display of current distance to go  
=0 - Total traversing path displayed

DW 21 - Unassigned

DW 22 - RW - The distance to go is output in the length unit or angular unit selected in DW 8 (resolution).  
In the case of very long traversing paths (residual pulse number greater than 32767), the total traversing path is displayed and, as soon as the residual pulse number is below 32767, the current distance to go is displayed.

DW 23 - IP - IP status (see Chapter 4.3.2)

The status bits of the IP are stored right-justified in this data word.

Bit 0 - IJE	Bit 1 - DGS	Bit 2 - IES
Bit 3 - IRP	Bit 4 - ILSS	Bit 5 - ILSE
Bit 6 - IDG	Bit 7 - IPQ	Bit 8 - IPD
Bit 9 - ILCN		



Function block for assigning parameters to the IP 267 \_\_\_\_\_ IP 267

DB17

LAE=30 /40

```
0:    KH = 0000;
1:    KF = +00000;          CONF./POS. [0/1]
2:    KH = 0000;
3:    KF = +00000;          BV [4;8;20;40;80;200;400;800]
4:    KY = 000,000;        0,FACTOR SS-RATE [1...255]
5:    KY = 000,000;        0,TIME INTERVAL [1...255]
6:    KF = +00000;        LIMIT SWITCH CONFIGURATION [0/1]
7:    KH = 0000;
8:    KF = +00200;        RESOLUTION [1...32767 Imp/LU]
9:    KH = 0000;
10:   KY = 000,000;        0,VELOCITY FACTOR [1...255]
11:   KF = +00000;        REDUCTION FACTOR [0/1] => 1/0.1
12:   KF = +00000;        OPERATING MODE
13:   KF = +00000;        PATH [1...32767 LU]
14:   KH = 0000;
15:   KM = 00000000 00000000;    FROM IP - BYTE 0 AND 1
16:   KM = 00000000 00000000;    - BYTE 2 AND 3
17:   KM = 00000000 00000000;    TO   IP - BYTE 0 AND 1
18:   KM = 00000000 00000000;    - BYTE 2 AND 3
19:   KH = 0000;
20:   KM = 00000000 00000000;    FB STATUS AND ERROR MESSAGES
21:   KH = 0000;
22:   KF = +00000;        DISTANCE TO GO [1...32767 LU]
23:   KM = 00000000 00000000;    IP STATUS
24:   KH = 0000;
25:
```

## 7.5 Calling function block 17

### OB 1

Before calling the FB 17, the user data block must be opened and the relevant input data words (see Chapter 4) transferred from the PII to data words 15 and 16.

After processing the function block, data words 17 and 18 must be transferred to the PIQ.

OB 1 LAE=17

SEGMENT 1            0000

0000	:C	DB	17	OPENING THE USER DB
0001	:L	IW	64	IWxx CORRESPONDS TO SLOT
0002	:T	DW	15	STORE FEEDBACK MESSAGE FRAME
0003	:L	IW	66	FROM IP
0004	:T	DW	16	
0005	:JU	FB	17	
0006	NAME	:IP-BED		
0007	:L	DW	17	TRANSMIT POSITIONING
0008	:T	QW	64	OR CONFIGURING
0009	:L	DW	18	MESSAGE FRAME TO IP
000A	:T	QW	66	QWXX CORRESPONDS TO SLOT
000B	:BE			

### OB 21

When initializing FW 110, the configuration data is deleted and transferred again, and the axis referenced again in the user FB (FB 19) following a warm restart.

OB 21 LAE=9

SEGMENT 1            0000

0000	:L	KH	7F00	PROCESSING OF THE LAST SIX JOBS
0002	:T	FW	110	OF THE SEQUENCER IS STARTED!
0003	:BE			



Function block for assigning parameters to the IP 267 \_\_\_\_\_ IP 267

**OB 22**

When initializing FW 110, the configuration data is sent to the IP and the axis referenced again in the user FB (FB 19) following a cold restart.

OB 22

LAE=9

```
SEGMENT 1      0000
0000      :L   KH FF00          PROCESSING OF THE LAST FIVE JOBS
0002      :T   FW 110          OF THE SEQUENCER IS STARTED!
0003      :BE
```

# Index

## A

Abortion/interruption	
- positioning jobs	4-11
Acceleration curve	2-4
Acceleration ramp	2-2, 2-4
Address area	1-1, 4-1
Address assignment	5-3
- configuration message frames	4-4
- feedback message frames	4-16
- positioning message frames	4-9
Addresses	1-1
Addressing	
- configuration message frames	4-3
Assigning parameters	7-1
Auxiliary approach jobs	6-14

## B

Base value (BV)	2-3
- for the stepping rate	2-2
- frequencies	4-6, 4-10
- stepping rate	2-3
Block diagram of the IP 267	1-2
BV Base value for the frequencies	

## C

Cable length	
- permissible	3-7
Calibration	
- traversing range	3-4
Cold restart	6-2
Configuration	
- delete	4-15

Configuration	
- limit switch	2-2, 2-3
Configuration data	2-1, 2-2, 3-4, 4-2, 4-3
- configuration message frame	5-6
- setting	6-26
- valid	4-12
Configuration message frame	2-2, 4-3, 4-11, 5-11, 5-12
- addressing	4-3
- configuration data	5-6
Configuring the IP 267	4-3
Connecting cables	
- power sections	3-9
Connector	3-8
- stepper motor power section	
Constant velocity range	2-2
Contact bounce	5-10
Control pulses	3-7
Current consumption	3-2

## D

Deceleration	
- curve	2-4
- phase	2-3
- ramp	2-2, 2-4
Diagnostics sheet	5-16
Differential signals	
- 5 V	3-6, 5-14
Differential inputs	
- 5V	1-1
Digital inputs	
- I -	2-4
- I +	2-4
Digital inputs	
- technical specifications	3-4

Distance to go	2-1, 4-2, 4-15, 4-18	I+	- limit switch	5-6
Drive		Identifier bit	- reference point approach	4-8
- moment of inertia	6-29	Input addresses		4-1
Drive circuit		Input message frame		6-1
- technical specifications	3-6	Interface	- serial	1-1, 2-1, 4-2
Duration of the output impulses	2-3			
<b>E</b>		<b>L</b>		
Emergency limit switch (PD)	2-2, 3-4, 5-1, 5-6	LED	- "ABT"	3-4, 3-8
Emergency-OFF switch	5-1		- "ACT"	3-8
Enable signals			- "RDY"	2-2
- power section	5-4		- "RDY"	3-4
End switch configuration	2-2		- "RDY"	3-8
			- "RDY"	4-8
<b>F</b>			- "RDY"	5-6
$f_A$ Stepping rate		Limit switch		5-1
Feedback message	4-2	- configuration		2-3
Feedback message frames	4-15	- I -		5-6
- address assignment	4-16	- I+		5-6
Feedback signal	2-1	Load variations		5-12
$f_{max}$ Pulse frequency		Logic inputs	- range 5 V to 30 V	3-6
Frequency				
- base value (BV)	2-3, 4-6, 4-10	<b>M</b>		
- range	2-3	Message frame		2-1
$f_{ss}$ Start/stop rate		- "STOP" mode		4-11
Full-step mode	2-5	Mode	- "neutral"	4-12
		- "start backwards"		4-12
<b>H</b>		- "start forwards"		4-12
Half-step mode	2-5	Moment of inertia		6-27
		- drive		6-29
<b>I</b>		Motor		
I -		- number of steps		5-12
- digital inputs	2-4	- selection		5-12, 6-26
I -		- torque		6-29
- limit switch	5-6			
I+				
- digital inputs	2-4			

Multiplier			
- start/stop rate		2-4, 4-5	
- velocity		4-8, 4-10	
<b>N</b>			
Number of steps		3-7	
- motor		5-12	
<b>O</b>			
Operating modes		2-2, 4-8, 4-11	
Output addresses		4-1	
Output current		3-7	
Output message frame		6-1	
Output pulses		2-4	
- number		2-1	
Output signals		3-6, 5-15	
Output voltages		3-7	
<b>P</b>			
Path		4-11	
- definition		4-8	
PD Emergency limit switch			
PII Process input image			
Pin assignment			
- terminal block connector	3-3		
PIQ Process output image			
Positioning data		2-1, 2-2	
Positioning job		4-2, 4-8, 4-12	
- abortion/interruption		4-11	
Positioning message frame		4-8, 5-8, 5-11	
- address assignments		4-9	
Power section			
- connecting cable	3-9		
- enable signal	5-4		
- preparation	5-4		
- selection	5-14		
Power supply	3-1, 3-2		
Principle of operation of the IP 267		2-1	
Process			
- input image		4-1, 4-2, 4-15	
- output image		4-1, 4-2	
Programmable pulse generator		1-1	
Pulse duration		4-7	
Pulse frequency		2-1, 5-12,	
		5-14	
- maximum		5-13	
Pulse generator			
- programmable		1-1	
Pulse output			
- inhibit		3-4	
<b>R</b>			
R Reduction factor			
Rate			
- start/stop		2-3	
- start/stop ( $f_{ss}$ )		2-4	
Rate decrease			
- time interval		4-5	
Reduction factor		4-7, 4-8,	
		4-10, 4-13	
- start/stop rate ( $f_{ss}$ )		2-3	
Reference point		5-8, 6-14	
- determination		5-8, 6-14	
Reference point approach		4-13	
- identifier bit		4-8	
Reference switch		3-4, 5-8	
RPA Reference point approach			
<b>S</b>			
Safety concept		5-1	
Serial interface		1-1, 2-1, 4-2	
Signal evaluation		3-4	
Slots		4-1	
Special voltage $V_s$		3-2, 3-6, 5-4	
SS Multiplier for the start/stop rate			

Start/stop rate ( $f_{ss}$ )	2-2, 2-3, 2-4	Torque	5-12
- multiplier	2-4, 4-5	- characteristic	5-13, 5-14
- reduction factor	2-4	- motor	6-29
Status	4-2	- stepper motor	2-5
- bit	2-1, 4-15, 4-17	Traverse profile	
- displays	3-8	- symmetrical	2-2
Step		Traversing range	5-8
- losses	5-12	- calibration	3-4
- pulses	4-11	- limitation	3-4
Stepper motor		Two-wire BEROs	
- torque	2-5	- supply voltage	3-5
Stepper motor power section		<b>V</b>	
- connection	3-6	Velocity	
Stepping rate ( $f_A$ )	2-4, 3-7, 4-5, 4-10	- multiplier	4-8, 4-10
- base value	2-2, 2-3	$V_s$ Special voltage	
Stepping rate decrease		<b>W</b>	
- time interval	2-2	Warm restart	6-2
Stepping rate increase		- routines	6-2
- time interval	2-2		
STOP mode			
- message frames	4-11		
Supply voltage			
- two-wire BEROs	3-5		
Symmetrical traverse profile	2-2		
<b>T</b>			
Technical specifications			
- digital inputs	3-4		
- drive circuit	3-6		
- general	3-1		
Terminal block connector			
- pin assignment	3-3		
TI Time interval			
Time interval (TI)	2-4		
- for stepping rate decrease	2-2		
- for stepping rate increase	2-2		
- rate decrease	4-5		
- rate increase	4-5		

**Siemens AG  
AUT E1114B  
Postfach 1963  
Werner-von-Siemens-Str. 50**

**D-92209 Amberg  
Fed. Rep. of Germany**

From:  Name <hr/> Company/Dept. <hr/> Address <hr/> Tel. No.	Suggestions
	Corrections
	<b>For Publication / Manual:</b>
	<b>Title: IP 267 Stepper Motor Controller</b>
	<b>Order No.: 6ES5 998-5SD21</b>
	<b>Edition: 3</b>
	Should you come across any printing errors when reading this publication, we would ask you to inform us accordingly, using this form. We would also welcome any suggestions you may have in the way of improvement.

**Suggestions and / or corrections**