

Silicon NPN Power Transistors

2SC940

DESCRIPTION

- With TO-3 package
- High current capability
- Wide area of safe operation

APPLICATIONS

- For B/W TV horizontal deflection application

PINNING (See Fig.2)

PIN	DESCRIPTION
1	Base
2	Emitter
3	Collector

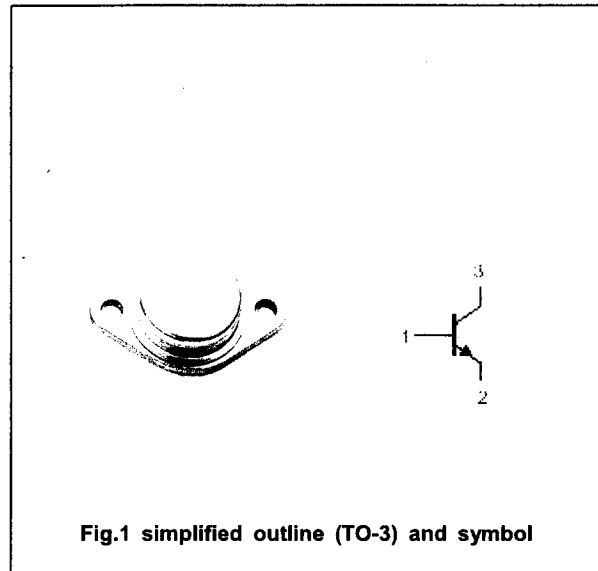
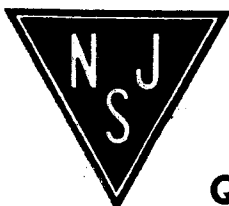

Fig.1 simplified outline (TO-3) and symbol

Absolute maximum ratings(Ta=25?)

SYMBOL	PARAMETER	CONDITIONS	VALUE	UNIT
V _{CBO}	Collector-base voltage	Open emitter	200	V
V _{CEO}	Collector-emitter voltage	Open base	90	V
V _{EBO}	Emitter-base voltage	Open collector	7	V
I _C	Collector current		7.5	A
I _{CM}	Collector current-peak		15	A
P _T	Total power dissipation	T _{mb} =25?	50	W
T _j	Junction temperature		150	?
T _{stg}	Storage temperature		-65~150	?



CHARACTERISTICS

T_J=25° unless otherwise specified

SYMBOL	PARAMETER	CONDITIONS	MIN	TYP.	MAX	UNIT
V _{CE0(SUS)}	Collector-emitter sustaining voltage	I _C =100mA ; I _B =0	90			V
V _{(BR)EBO}	Emitter-base breakdown voltage	I _E =1mA ; I _C =0	7			V
V _{CEsat}	Collector-emitter saturation voltage	I _C =5A ; I _B =0.5A			1.5	V
I _{CBO}	Collector cut-off current	V _{CB} =90V ; I _E =0			0.1	mA
I _{EBO}	Emitter cut-off current	V _{EB} =5V ; I _C =0			0.1	mA
h _{FE}	DC current gain	I _C =5A ; V _{CE} =5V	15		70	
f _T	Transition frequency	I _C =0.5A ; V _{CE} =10V		20		MHz

◆ h_{FE-2} Classifications

O	Q	P
15-35	25-45	35-70

PACKAGE OUTLINE

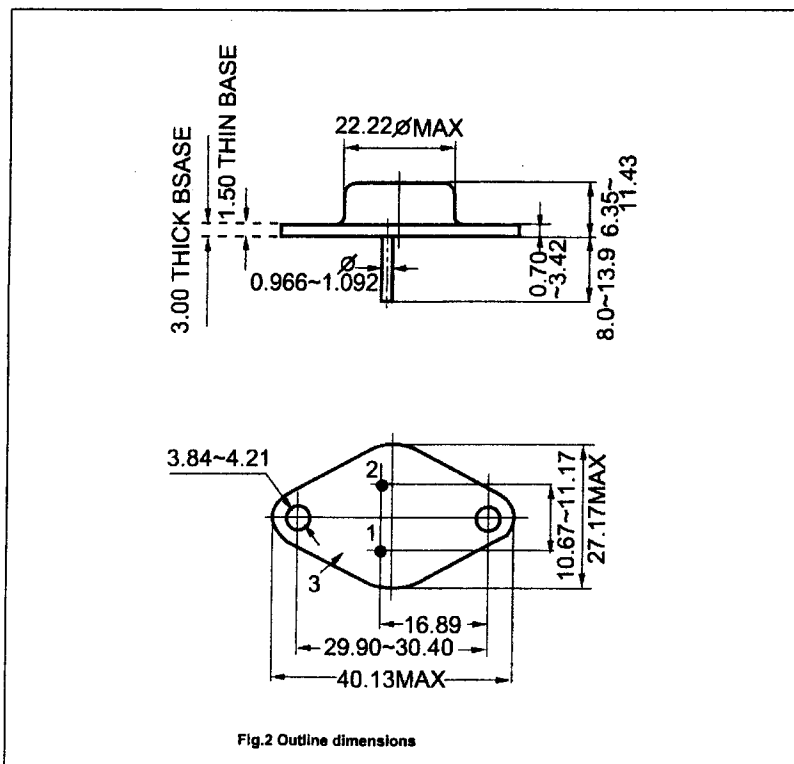

Fig.2 Outline dimensions