



54VCXHR162245

Rad hard low voltage CMOS 16-bit bus buffer transceiver (3-state) with 3.6 V tolerant inputs and outputs

Features

- 1.65 to 3.6 V inputs and outputs
- High speed in both A, B outputs:
 - $t_{PD} = 3.4$ ns at $V_{CC} = 3.0$ to 3.6 V
 - $t_{PD} = 4.3$ ns at $V_{CC} = 2.3$ to 2.7 V
- Symmetrical impedance outputs:
 - $|I_{OH}| = I_{OL} = 12$ mA (Min.) at $V_{CC} = 3.0$ V
 - $|I_{OH}| = I_{OL} = 8$ mA (Min.) at $V_{CC} = 2.3$ V
- Power down protection on inputs and outputs
- 26 Ω serie resistors in bith A and B port outputs
- Operating voltage range:
 - $V_{CC}(Opr) = 1.65$ V to 3.6 V
- Pin and function compatible with 54 series HR162245
- Bus hold provided on both sides
- Cold spare function
- Latch-up performance exceeds 300 mA (JESD 17)
- ESD performance:
 - HBM > 2000 V (MIL STD 883 method 3015); MM > 200 V
- 300 krad Mil1019.6 condition A, (RHA QML qualification extension undergone)
- No SEL, no SEU and no SET under 110 Mev/cm²/mg LET heavy ions irradiation
- QML qualified product
- Device fully compliant with DSCC SMD 5962-05213
- 100 mV typical input hysteresis

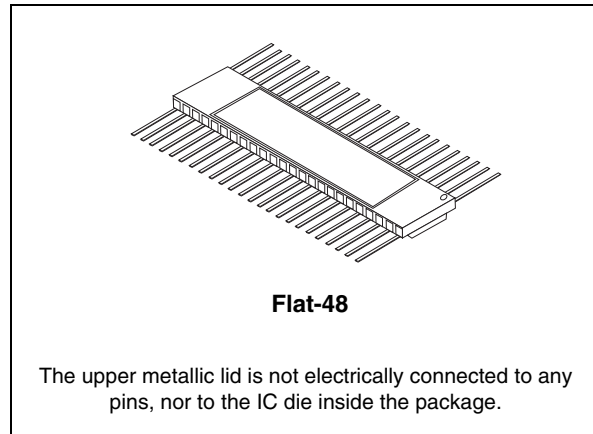

Description

The 54VCXHR162245 is a low voltage CMOS 16 bit bus transceiver (3-state) fabricated with sub-micron silicon gate and five-layer metal wiring C²MOS technology. It is ideal for low power and very high speed 1.65 to 3.6 V applications; it can be interfaced to 3.6 V signal environment for both inputs and outputs. This IC is intended for two-way asynchronous communication between data buses; the direction of data transmission is determined by DIR input. The two enable inputs $n\bar{G}$ can be used to disable the device so that the buses are effectively isolated. The device circuits is including 26 Ω series resistance in the A and B port outputs. These resistors permit to reduce line noise in high speed applications. Bus hold on data inputs is provided in order to eliminate the need for external pull-up or pull-down resistor. All inputs and outputs are equipped with protection circuits against static discharge, giving them 2 kV ESD immunity and transient excess voltage. All floating bus terminals during high Z State must be held HIGH or LOW.

Contents

- 1 Logic symbols and I/O equivalent circuit 3**

- 2 Pin settings 4**
 - 2.1 Pin connection 4
 - 2.2 Pin description 5
 - 2.3 Truth table 5

- 3 Maximum rating 6**
 - 3.1 Recommended operating conditions 7

- 4 Electrical characteristics 8**

- 5 Test circuit 11**

- 6 Waveforms 12**

- 7 Package mechanical data 14**

- 8 Order codes 16**

- 9 Revision history 17**

1 Logic symbols and I/O equivalent circuit

Figure 1. IEC logic symbols

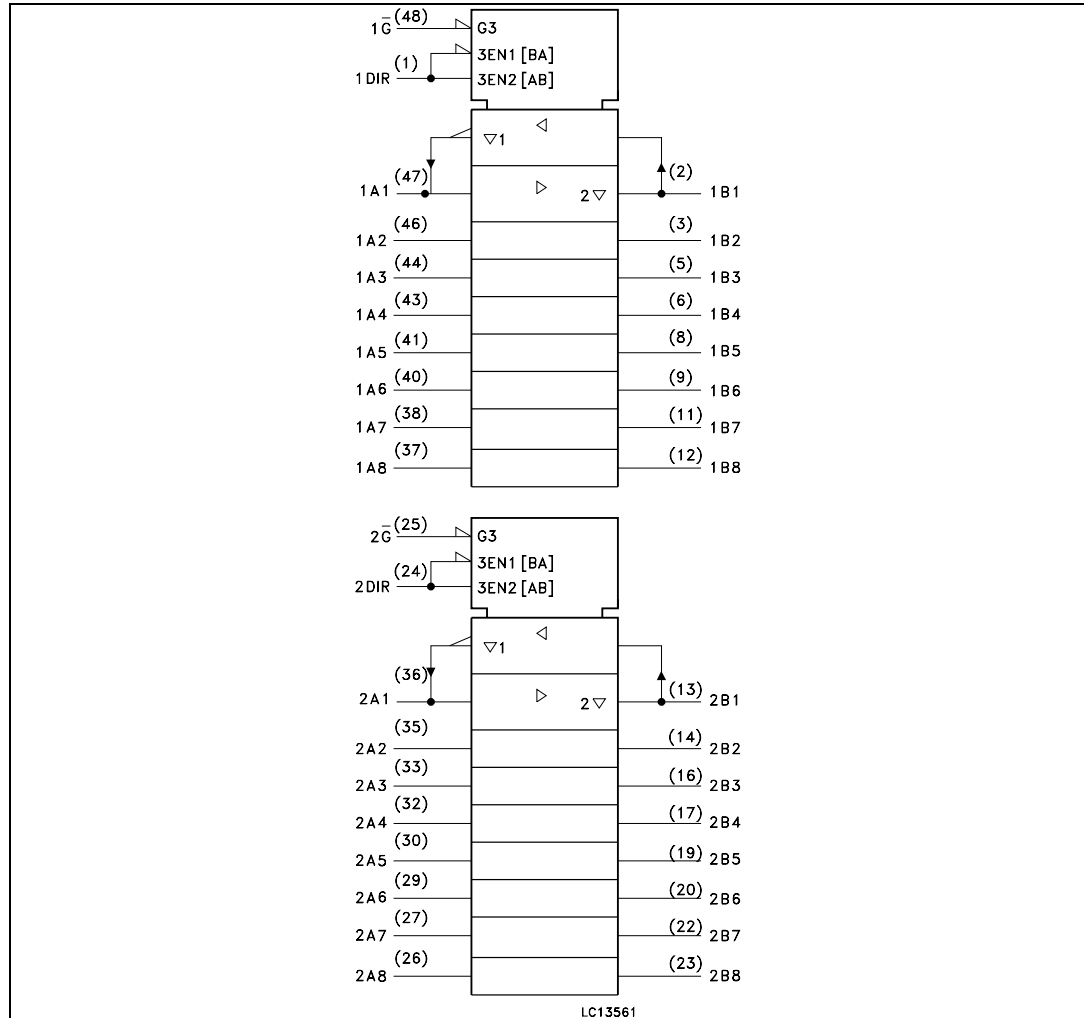
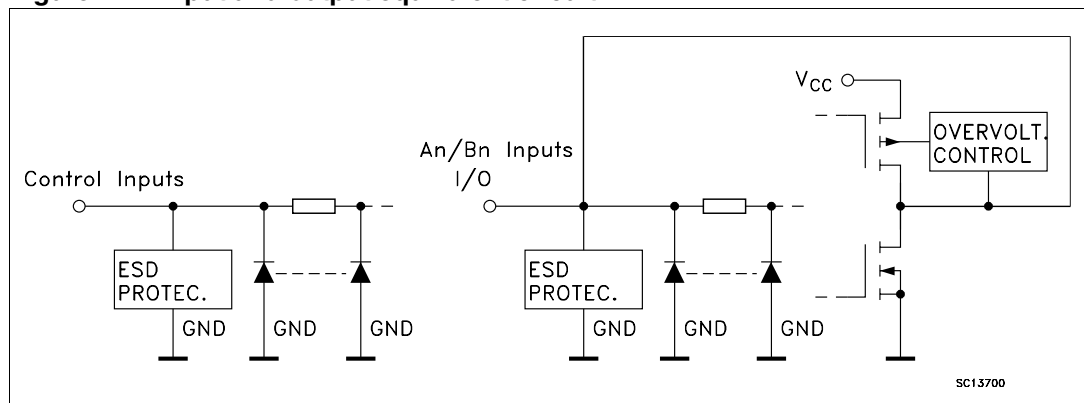

Figure 2. Input and output equivalent circuit



2 Pin settings

2.1 Pin connection

Figure 3. Pin connection (top through view)

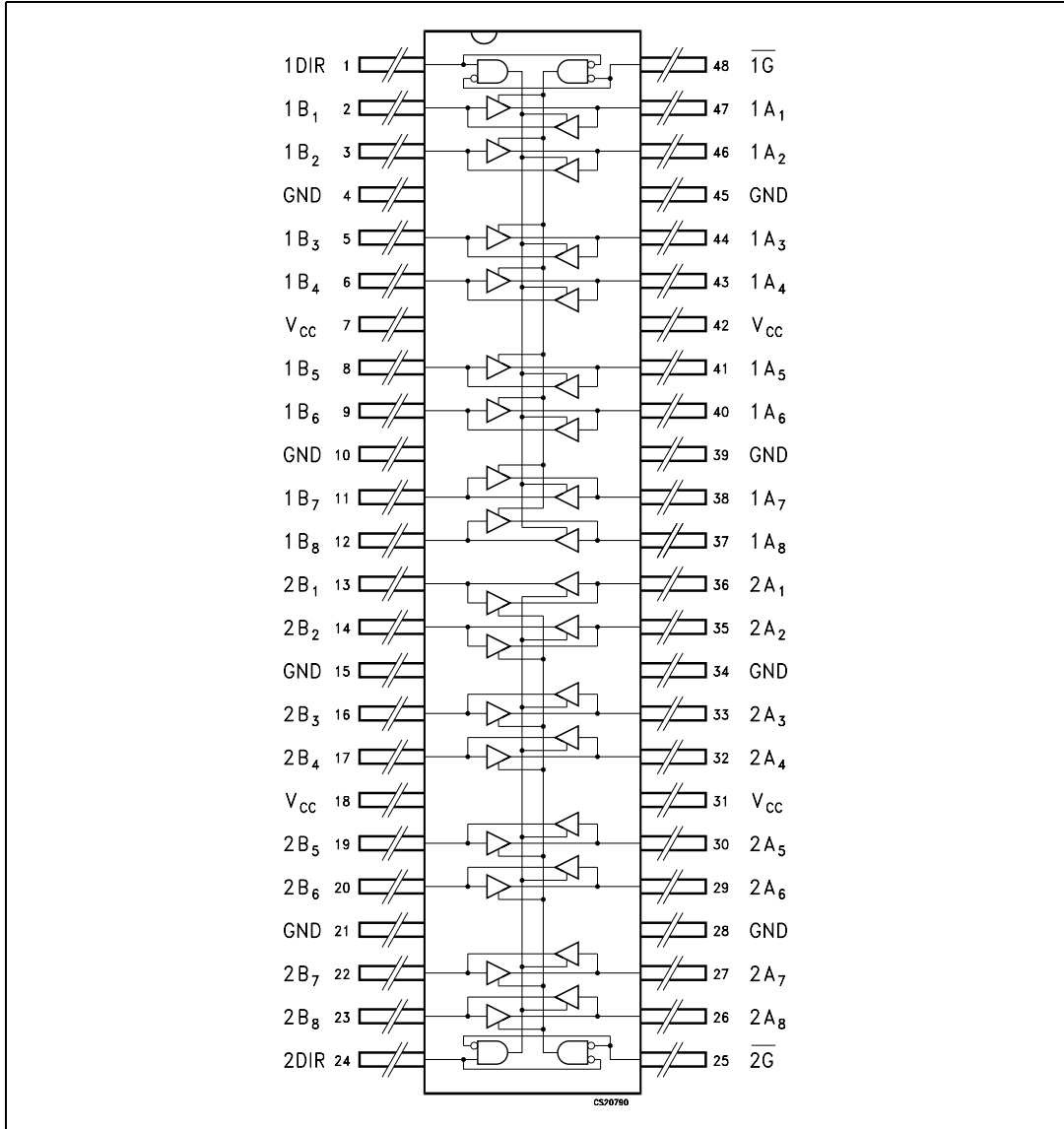

2.2 Pin description

Table 1. Pin description

Pin n°	Symbol	Name and function
1	1DIR	Directional control
2, 3, 5, 6, 8, 9, 11, 12	1B1 to 1B8	Data inputs/outputs
13, 14, 16, 17, 19, 20, 22, 23	2B1 to 2B8	Data inputs/outputs
24	2DIR	Directional control
25	$2\bar{G}$	Output enable input
36, 35, 33, 32, 30, 29, 27, 26	2A1 to 2A8	Data inputs/outputs
47, 46, 44, 43, 41, 40, 38, 38	1A1 to 1A8	Data inputs/outputs
48	$1\bar{G}$	Output enable input
4, 10, 15, 21, 28, 34, 39, 45	GND	Ground (0 V)
7, 18, 31, 42	V _{CC}	Positive supply voltage

2.3 Truth table

Table 2. Truth table

Inputs		Function		Output
\bar{G}	DIR	A bus	B bus	Yn
L	L	OUTPUT	INPUT	A = B
L	H	INPUT	OUTPUT	B = A
H	X	Z	Z	Z

Note: X = Do not care; Z = High impedance

3 Maximum rating

Stressing the device above the rating listed in the “absolute maximum ratings” table may cause permanent damage to the device. These are stress ratings only and operation of the device at these or any other conditions above those indicated in the operating sections of this specification is not implied. Exposure to absolute maximum rating conditions for extended periods may affect device reliability.

Table 3. Absolute maximum ratings

Symbol	Parameter	Value	Unit
V_{CC}	Supply voltage	-0.5 to +4.6	V
V_I	DC input voltage	-0.5 to +4.6	V
V_O	DC output voltage (OFF state)	-0.5 to +4.6	V
V_O	DC output voltage (high or low state) ⁽¹⁾	-0.5 to $V_{CC} + 0.5$	V
I_{IK}	DC input diode current	- 50	mA
I_{OK}	DC output diode current ⁽²⁾	- 50	mA
I_O	DC output current	± 50	mA
I_{CC} or I_{GND}	DC V_{CC} or ground current per supply pin	± 100	mA
P_D	Power dissipation	400	mW
T_{stg}	Storage temperature	-65 to +150	°C
T_L	Lead temperature (10 sec)	260	°C

1. I_O absolute maximum rating must be observed
2. $V_O < GND$, $V_O > V_{CC}$

3.1 Recommended operating conditions

Table 4. Recommended operating conditions

Symbol	Parameter	Value	Unit
V_{CC}	Supply voltage	1.8 to 3.6	V
V_I	Input voltage	-0.3 to 3.6	V
V_O	Output voltage (OFF state)	0 to 3.6	V
V_O	Output voltage (high or low state)	0 to V_{CC}	V
I_{OH}, I_{OL}	High or low level output current ($V_{CC} = 3.0$ to 3.6 V)	± 12	mA
I_{OH}, I_{OL}	High or low level output current ($V_{CC} = 2.3$ to 2.7 V)	± 8	mA
T_{op}	Operating temperature	-55 to 125	°C
dt/dv	Input rise and fall time ⁽¹⁾	0 to 10	ns/V

1. V_{IN} from 0.8 V to 2 V at $V_{CC} = 3.0$ V

4 Electrical characteristics

2.7 V < V_{CC} < 3.6 V unless otherwise specified.

Table 5. DC specifications

Symbol	Parameter	Test condition		Value		Unit
		V_{CC} (V)		-55 to 125 °C		
				Min.	Max.	
V_{IH}	High level input voltage	2.7 to 3.6		2.0		V
V_{IL}	Low level input voltage				0.8	
V_{OH}	High level output voltage	2.7 to 3.6	$I_O = -100 \mu A$	$V_{CC} - 0.2$		V
		2.7	$I_O = -6 \text{ mA}$	2.2		
		3.0	$I_O = -8 \text{ mA}$	2.4		
			$I_O = -12 \text{ mA}$	2.2		
V_{OL}	Low level output voltage	2.7 to 3.6	$I_O = 100 \mu A$		0.2	V
		2.7	$I_O = 6 \text{ mA}$		0.4	
		3.0	$I_O = 8 \text{ mA}$		0.55	
			$I_O = 12 \text{ mA}$		0.8	
I_I	Input leakage current	2.7 to 3.6	$V_I = 0 \text{ to } 3.6 \text{ V}$		± 5	μA
$I_{I(HOLD)}$	Input hold current	3.0	$V_I = 0.8 \text{ V}$	75		μA
			$V_I = 2 \text{ V}$	-75		
		3.6	$V_I = 0 \text{ to } 3.6 \text{ V}$		± 500	
I_{off}	Power off leakage current	0	$V_I \text{ or } V_O = 0 \text{ to } 3.6 \text{ V}$		10	μA
I_{OZ}	High impedance output leakage current	2.7 to 3.6	$V_I = V_{IH} \text{ or } V_{IL}$ $V_O = 0 \text{ to } 3.6 \text{ V}$		± 10	μA
I_{CC}	Quiescent supply current	2.7 to 3.6	$V_I = V_{CC} \text{ or } GND$		20	μA
			$V_I \text{ or } V_O = V_{CC} \text{ to } 3.6 \text{ V}$		± 20	
ΔI_{CC}	I_{CC} incr. per input	2.7 to 3.6	$V_{IH} = V_{CC} - 0.6 \text{ V}$		750	μA

2.3 V < V_{CC} < 2.7 V unless otherwise specified.

Table 6. DC specifications

Symbol	Parameter	Test condition		Value			Unit
		V _{CC} (V)		-55 to 125 °C			
				Min.	Max.		
V _{IH}	High level input voltage	2.3 to 2.7		1.6		V	
V _{IL}	Low level input voltage				0.7		
V _{OH}	High level output voltage	2.3 to 2.7	I _O =-100 μA	V _{CC} -0.2		V	
		2.3	I _O =-4 mA	2.0			
			I _O =-6 mA	1.8			
			I _O =-8 mA	1.7			
V _{OL}	Low level output voltage	2.3 to 2.7	I _O =100 μA		0.2	V	
		2.3	I _O =6 mA		0.4		
			I _O =8 mA		0.6		
I _I	Input leakage current	2.3 to 2.7	V _I = V _{CC} or GND		± 5	μA	
I _{I(HOLD)}	Input hold current	2.3	V _I = 0.7 V	45		μA	
			V _I = 1.7 V	-45			
I _{off}	Power off leakage current	0	V _I or V _O = 0 to 3.6 V		10	μA	
I _{OZ}	High impedance output leakage current	2.3 to 2.7	V _I = V _{IH} or V _{IL} V _O = 0 to 3.6 V		± 10	μA	
I _{CC}	Quiescent supply current	2.3 to 2.7	V _I = V _{CC} or GND		20	μA	
			V _I or V _O = V _{CC} to 3.6 V		± 20		

T_A = 25 °C, Input t_r = t_f = 2.0 ns, C_L = 30 pF, R_L = 500 Ω

Table 7. Dynamic switching characteristics

Symbol	Parameter	Test condition		Value			Unit
		V _{CC} (V)		T _A = 25 °C			
				Min.	Typ.	Max.	
V _{OLV}	Dynamic valley low voltage quiet output ⁽¹⁾ ⁽²⁾	2.5	V _{IL} = 0V V _{IH} = V _{CC}	-	0.25	-	V
		3.3		-	0.35	-	
V _{OHV}	Dynamic valley high voltage quiet output ⁽²⁾ ⁽³⁾	2.5	V _{IL} = 0V V _{IH} = V _{CC}	-	-0.25	-	V
		3.3		-	-0.35	-	
V _{OHV}	Dynamic valley high voltage quiet output ⁽²⁾ ⁽³⁾	2.5	V _{IL} = 0V V _{IH} = V _{CC}	-	2.05	-	V
		3.3		-	2.65	-	

- Number of outputs defined as "n". Measured with "n-1" outputs switching from HIGH to LOW or LOW to HIGH. The remaining output is measured in the LOW state.
- Parameters guaranteed by design.
- Number of outputs defined as "n". Measured with "n-1" outputs switching from HIGH to LOW or LOW to HIGH. The remaining output is measured in the HIGH state.

$C_L = 30 \text{ pF}$, $R_L = 500 \text{ } \Omega$, Input $t_r = t_f = 2.0 \text{ ns}$

Table 8. AC electrical characteristics

Symbol	Parameter	Test condition		Value		Unit
		V_{CC} (V)		-55 to 125 °C		
				Min.	Max.	
t_{PLH} t_{PHL}	Propagation delay time	2.3 to 2.7		1.0	4.0	ns
		3.0 to 3.6		0.8	3.6	
t_{PLH} t_{PHL}	Propagation delay time	2.3 to 2.7		1.0	4.9	ns
		3.0 to 3.6		0.8	4.0	
t_{PZL} t_{PZH}	Output enable time	2.3 to 2.7		1.0	5.8	ns
		3.0 to 3.6		0.8	4.3	
t_{PZL} t_{PZH}	Output enable time	2.3 to 2.7		1.0	6.8	ns
		3.0 to 3.6		0.8	4.8	
t_{PLZ} t_{PHZ}	Output disable time	2.3 to 2.7		1.0	4.8	ns
		3.0 to 3.6		0.8	5.6	
t_{PLZ} t_{PHZ}	Output disable time	2.3 to 2.7		1.0	5.7	ns
		3.0 to 3.6		0.8	7.0	
t_{OSLH} t_{OSHL}	Output to output skew time ⁽¹⁾ ⁽²⁾	2.3 to 2.7			0.5	ns
		3.0 to 3.6			0.5	

1. Skew is defined as the absolute value of the difference between the actual propagation delay for any two outputs of the same device switching in the same direction, either HIGH or LOW ($t_{OSLH} = |t_{PLHm} - t_{PLHn}|$, $t_{OSHL} = |t_{PHLm} - t_{PHLn}|$)

2. Parameter guaranteed by design

Table 9. Capacitive characteristics

Symbol	Parameter	Test condition		Value			Unit
		V_{CC} (V)		$T_A = 25 \text{ } ^\circ\text{C}$			
				Min.	Typ.	Max.	
C_{IN}	Input capacitance	2.5 or 3.3	$V_{IN} = 0 \text{ or } V_{CC}$	-	4	-	pF
C_{OUT}	Output capacitance	2.5 or 3.3	$V_{IN} = 0 \text{ or } V_{CC}$	-	8	-	pF
C_{PD}	Power dissipation capacitance ⁽¹⁾	2.5 or 3.3	$f_{IN} = 10 \text{ MHz}$ $V_{IN} = 0 \text{ or } V_{CC}$	-	28	-	pF

1. C_{PD} is defined as the value of the IC's internal equivalent capacitance which is calculated from the operating current consumption without load. (Refer to test circuit). Average operating current can be obtained by the following equation. $I_{CC(opr)} = C_{PD} \times V_{CC} \times f_{IN} + I_{CC}/16$ (per circuit)

5 Test circuit

Figure 4. Test circuit

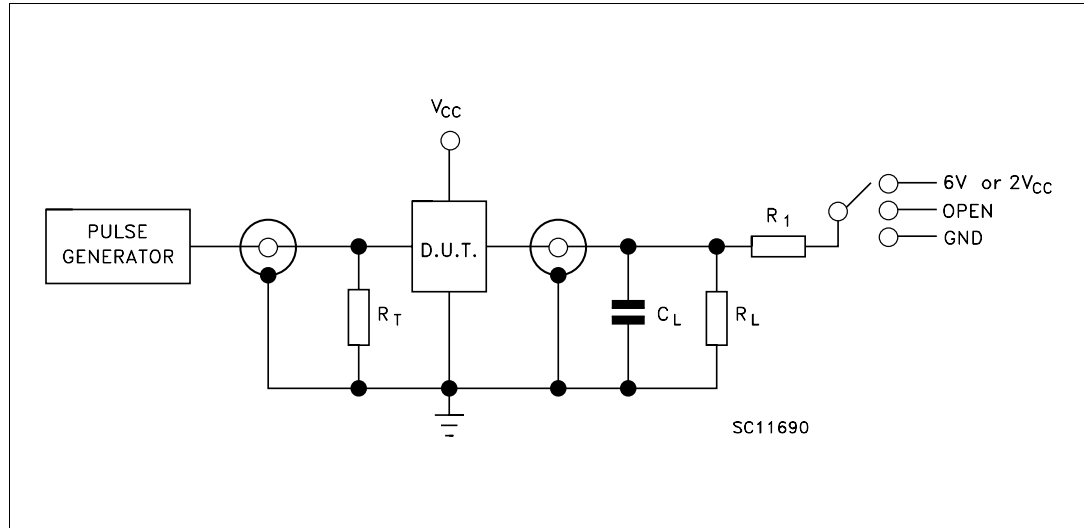

Table 10. Test circuit

Test	Switch
t_{PLH} , t_{PHL}	Open
t_{PZL} , t_{PLZ} ($V_{CC} = 3.0$ to 3.6 V)	6 V
t_{PZL} , t_{PLZ} ($V_{CC} = 2.3$ to 2.7 V)	$2 V_{CC}$
t_{PZH} , t_{PHZ}	GND

$C_L = 30$ pF or equivalent (includes jig and probe capacitance)

$R_L = R_1 = 500 \Omega$ or equivalent

$R_T = Z_{OUT}$ of pulse generator (typically 50Ω)

6 Waveforms

Table 11. Waveform symbol value

Symbol	V _{CC}	
	3.0 to 3.6 V	2.3 to 2.7 V
V _{IH}	2.7 V	V _{CC}
V _M	1.5 V	V _{CC} /2
V _X	V _{OL} + 0.3 V	V _{OL} + 0.15 V
V _Y	V _{OH} - 0.3 V	V _{OH} - 0.15 V

Figure 5. Waveform - propagation delay (f = 1 MHz; 50 % duty cycle)

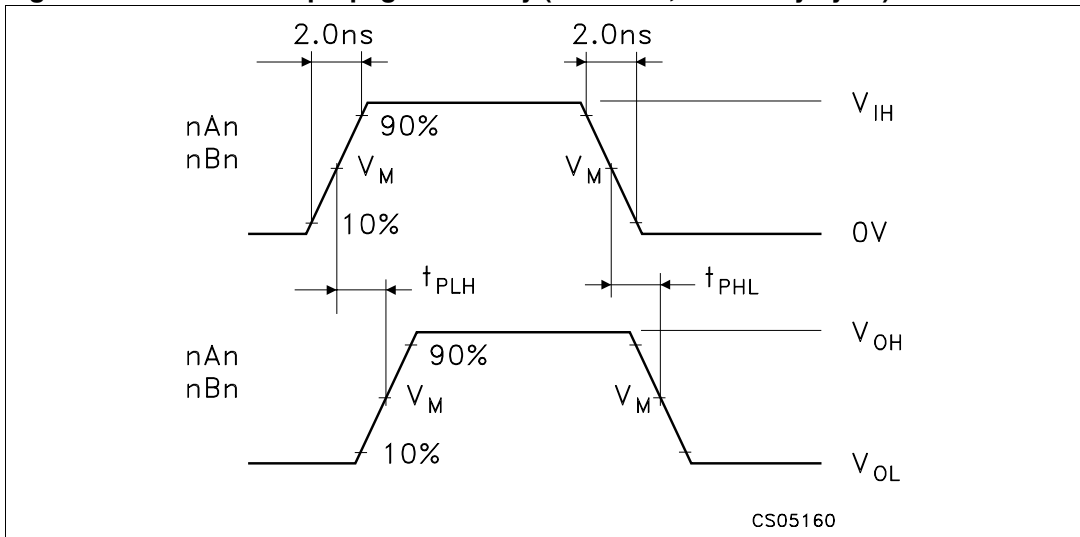
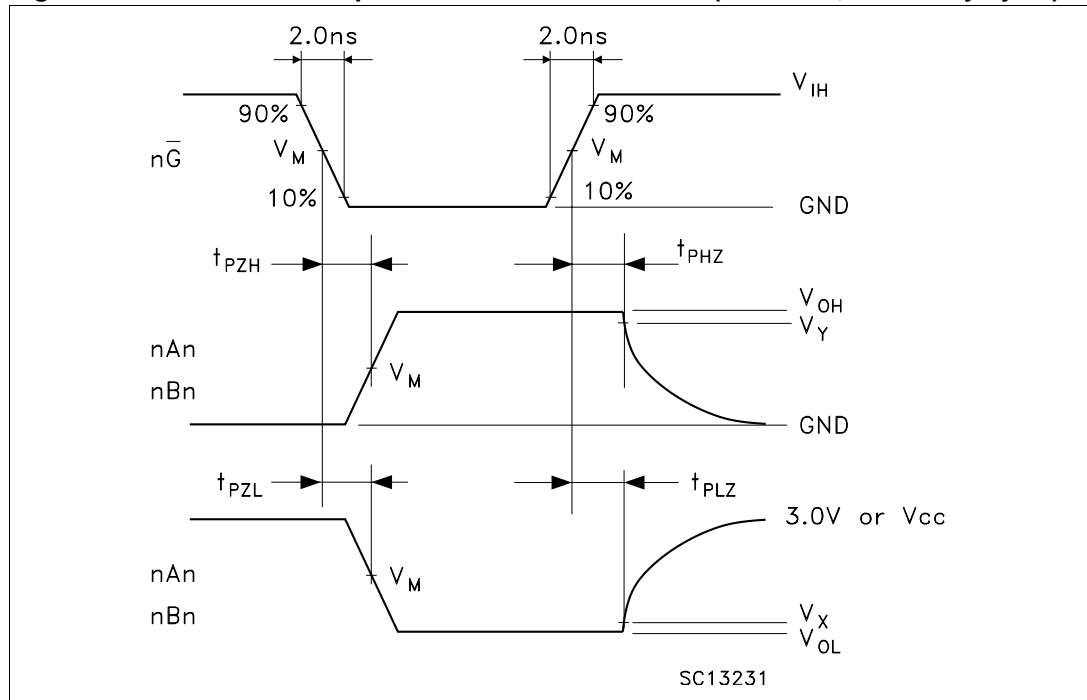

Figure 6. Waveform - output enable and disable time (f = 1 MHz; 50 % duty cycle)



7 Package mechanical data

54VCXHR162245 products are supplied into ceramic body / metal lid hermetic Flat 48-pin space package.

In order to meet environmental requirements, ST offers these devices in different grades of ECOPACK[®] packages, depending on their level of environmental compliance. ECOPACK[®] specifications, grade definitions and product status are available at: www.st.com. ECOPACK[®] is an ST trademark.

Table 12. Flat-48 (MIL-STD-1835) mechanical data

Dim.	mm			inch		
	Min.	Typ.	Max.	Min.	Typ.	Max.
A	2.18	2.47	2.72	0.086	0.097	0.107
b	0.20	0.254	0.30	0.008	0.010	0.012
c	0.12	0.15	0.18	0.005	0.006	0.007
D	15.57	15.75	15.92	0.613	0.620	0.627
E	9.52	9.65	9.78	0.375	0.380	0.385
E2	6.22	6.35	6.48	0.245	0.250	0.255
E3	1.52	1.65	1.78	0.060	0.065	0.070
e		0.635			0.025	
f		0.20			0.008	
L	6.85	8.38	9.40	0.270	0.330	0.370
Q	0.66	0.79	0.92	0.026	0.031	0.036
S1	0.25	0.43	0.61	0.010	0.017	0.024

Figure 7. Package dimension

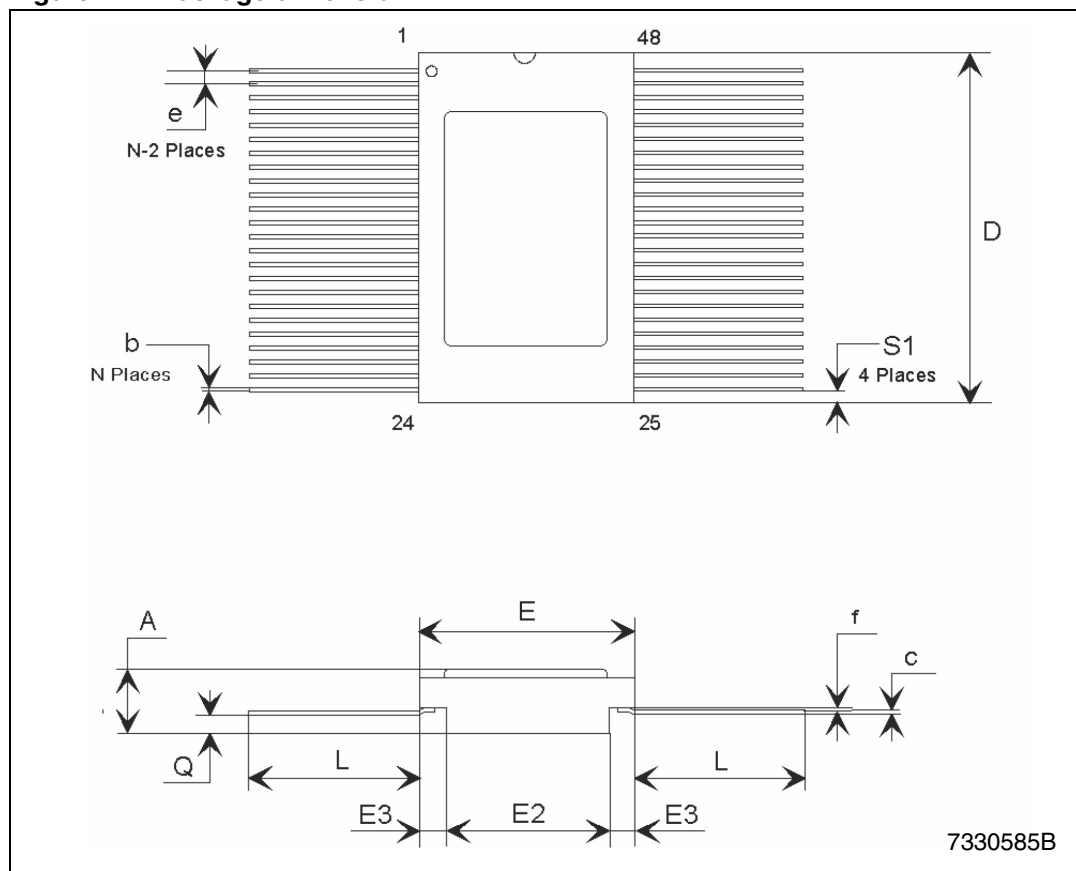

7330585B

Note: The upper metallic lid is not electrically connected to any pins, nor to the IC die inside the package. Connecting unused pins or metal lid to ground or to the power supply will not affect the electrical characteristics.

8 Order codes

Table 13. Ordering information

Package	Min op. voltage	Lead finish	Radiation level	Flight models	Engineering model	Packing
				QML-V		
48-pin flat	1.8 V	gold plated	300 krad	RHFXHR162245K03V	RHRXHR162245K1	Conductive strip pack

9 Revision history

Table 14. Document revision history

Date	Revision	Changes
09-Jul-2004	1	First release
17-May-2005	2	SMD qualified
19-Jun-2006	3	300Krad bullet updated, new template, mechanical data updated
11-Apr-2007	4	Updated cover page features
30-Jul-2007	5	Typo in Table 12 on page 14
17-Sep-2008	6	Updated cover page
08-Sep-2009	7	Updated Table 13 on page 16
02-Aug-2011	8	Added Note: on page 15 and in the "Pin connections" diagram on the coverpage

Please Read Carefully:

Information in this document is provided solely in connection with ST products. STMicroelectronics NV and its subsidiaries ("ST") reserve the right to make changes, corrections, modifications or improvements, to this document, and the products and services described herein at any time, without notice.

All ST products are sold pursuant to ST's terms and conditions of sale.

Purchasers are solely responsible for the choice, selection and use of the ST products and services described herein, and ST assumes no liability whatsoever relating to the choice, selection or use of the ST products and services described herein.

No license, express or implied, by estoppel or otherwise, to any intellectual property rights is granted under this document. If any part of this document refers to any third party products or services it shall not be deemed a license grant by ST for the use of such third party products or services, or any intellectual property contained therein or considered as a warranty covering the use in any manner whatsoever of such third party products or services or any intellectual property contained therein.

UNLESS OTHERWISE SET FORTH IN ST'S TERMS AND CONDITIONS OF SALE ST DISCLAIMS ANY EXPRESS OR IMPLIED WARRANTY WITH RESPECT TO THE USE AND/OR SALE OF ST PRODUCTS INCLUDING WITHOUT LIMITATION IMPLIED WARRANTIES OF MERCHANTABILITY, FITNESS FOR A PARTICULAR PURPOSE (AND THEIR EQUIVALENTS UNDER THE LAWS OF ANY JURISDICTION), OR INFRINGEMENT OF ANY PATENT, COPYRIGHT OR OTHER INTELLECTUAL PROPERTY RIGHT.

UNLESS EXPRESSLY APPROVED IN WRITING BY TWO AUTHORIZED ST REPRESENTATIVES, ST PRODUCTS ARE NOT RECOMMENDED, AUTHORIZED OR WARRANTED FOR USE IN MILITARY, AIR CRAFT, SPACE, LIFE SAVING, OR LIFE SUSTAINING APPLICATIONS, NOR IN PRODUCTS OR SYSTEMS WHERE FAILURE OR MALFUNCTION MAY RESULT IN PERSONAL INJURY, DEATH, OR SEVERE PROPERTY OR ENVIRONMENTAL DAMAGE. ST PRODUCTS WHICH ARE NOT SPECIFIED AS "AUTOMOTIVE GRADE" MAY ONLY BE USED IN AUTOMOTIVE APPLICATIONS AT USER'S OWN RISK.

Resale of ST products with provisions different from the statements and/or technical features set forth in this document shall immediately void any warranty granted by ST for the ST product or service described herein and shall not create or extend in any manner whatsoever, any liability of ST.

ST and the ST logo are trademarks or registered trademarks of ST in various countries.

Information in this document supersedes and replaces all information previously supplied.

The ST logo is a registered trademark of STMicroelectronics. All other names are the property of their respective owners.

© 2011 STMicroelectronics - All rights reserved

STMicroelectronics group of companies

Australia - Belgium - Brazil - Canada - China - Czech Republic - Finland - France - Germany - Hong Kong - India - Israel - Italy - Japan - Malaysia - Malta - Morocco - Philippines - Singapore - Spain - Sweden - Switzerland - United Kingdom - United States of America

www.st.com