



**Product Specification**
**Contents**

No	ITEM	Page
	COVER	1
	CONTENTS	2
	RECORD OF REVISIONS	3
1	GENERAL DESCRIPTION	4
2	ABSOLUTE MAXIMUM RATINGS	5
3	ELECTRICAL SPECIFICATIONS	
3-1	ELECTRICAL CHARACTERISTICS	6
3-2	INTERFACE (INPUT TERMINAL)	8
3-3	SIGNAL TIMING SPECIFICATIONS	10
3-4	TIMING DIAGRAM	11
3-5	DETAIL DESCRIPTION OF PIN FUNCTION	13
3-6	RECOMMENDED GAMMA CORRECTION VOLTAGE	13
4	OPTICAL SPECIFICATIONS	14
5	MECHANICAL CHARACTERISTICS	18
6	RELIABILITY	21
7	INTERNATIONAL STANDARDS	
7-1	SAFETY	22
7-2	EMC	22
8	PACKING	
8-1	DESIGNATION OF LOT MARK	23
8-2	PACKING FORM	23
9	PRECAUTIONS	24



**Product Specification**

**1. General Description**

The LB104S02 is a Color Active Matrix Liquid Crystal Display with an integral Cold Cathode Fluorescent Lamp (CCFL) backlight system. The matrix employs a-Si Thin Film Transistor as the active element. It is a transmissive type display operating in the normally white mode. This TFT-LCD has 10.4 inches diagonally measured active display area with SVGA resolution(800 horizontal by 600 vertical pixel array). Each pixel is divided into Red, Green and Blue sub-pixels or dots which are arranged in vertical stripes. Gray scale or the brightness of the sub-pixel color is determined with a 6-bit gray scale signal for each dot, thus, presenting a palette of more than 262,144 colors.

The LB104S02 has been designed to apply the interface method that enables low power, high speed, low EMI.

The LB104S02 is intended to support applications where thin thickness, low power are critical factors and graphic displays are important. In combination with the vertical arrangement of the sub-pixels, the LB104S02 characteristics provide an excellent flat display.

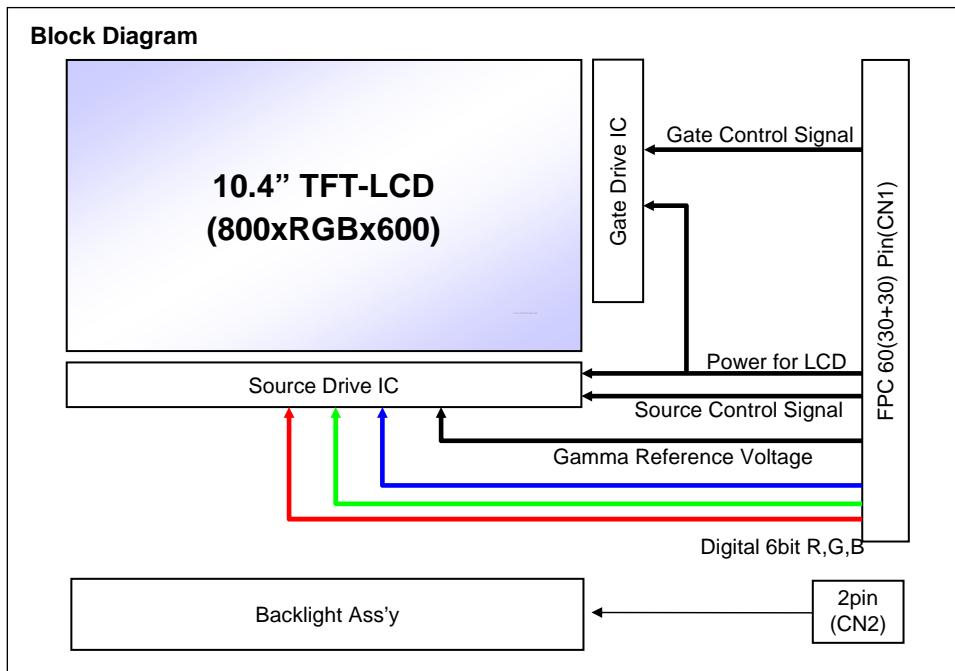

**General Features**

Active Screen Size	10.4 inches diagonal
Outline Dimension	234.7x178.6x6.8mm
Pixel Pitch	0.088x0.264 mm
Pixel Format	800 horiz. by 600 vert. Pixels RGB strip arrangement
Color Depth	6-bit, 262,144 colors
Luminance, White	250 cd/m <sup>2</sup> (Typ.)
Weight	420 g(Typ.)
Display Operating Mode	Transmitting type, normally white
Surface Treatment	Anti-glare treatment of the front polarizer



**Product Specification**
**3. Electrical Specifications**
**3-1. Electrical Characteristics**

The LB104S02 requires two power inputs. CN1 is employed to power the LCD electronics and to drive the TFT array and liquid crystal. CN2 input which powers the CCFL, is typically generated by one inverter. The inverters are external unit to the LCD.

**Table 2. ELECTRICAL CHARACTERISTICS(TFT-LCD PANEL DRIVING SECTION)**

 ( $T_a = 25^\circ C$ )

Parameter		Symbol	Min	Typ	Max	Unit	Remark	
Logic Supply Voltage		VCC	3.0	3.3	3.6	V		
Digital Input Signal	High Level	$V_{IH}$	0.7VCC	-	VCC	V		
	Low Level	$V_{IL}$	0	-	0.3VCC	V		
Source Driver Supply Voltage		AVDD	8.32	9.32	10.32	V		
Gate Driver	TFT	Hi	VGH	16.55	17.55	18.55	V	
		Lo	VGL		-4.99		V	
Gamma Correction Voltage		DC	V1 ~ V7	0.4AVDD	-	AVDD-0.1	V	
			V8 ~ V14	0.1	-	0.6AVDD		
Color Filter Substrate Voltage		DC	VCOM	3.6	3.9	4.1	V	
Source Driver Supply Current		IDD	-	38	50.0	mA	AVDD =9.32V	
Logic Supply Current		ICC	-	5	20.0	mA	VCC = 3.3V	
Gate Driver High Supply Current		IGH	-	0.80	2	mA	VGH = 17.55V	
Gate Driver Low Supply Current		IGL	-	0.32	1	mA	VGL =-4.99V	

\*\*\*\*\* Cautionary Matter : When applying or disconnecting power, please be sure that such action is sequentially carried out for all power supplies. In addition, apply input signals only after power has been turned on.

**[Power Sequence]**
**-Source Driver :**

Power on sequence : Case.1) VCC > Logic input > AVDD > V1 to V14.  
 Case.2) VCC > AVDD > V1 to V14 > Logic input.

Power off sequence is reverse turn of this.

**-Gate Driver :**

Power on sequence : VCC > VGL > Input signal > VGH.  
 Power off sequence is reverse turn of this.

**Product Specification**
**Table 3. ELECTRICAL CHARACTERISTICS(CCFL DRIVING SECTION)**
 $T_a=25$ 

Parameter	Symbol	Values			Unit	Notes
		Min	Typ	Max		
Operating Voltage	$V_{BL}$	720	800	880	$V_{RMS}$	1
Operating Current	$I_{BL}$	6.0	6.5	7.0	$mA_{RMS}$	2
Power Consumption	$P_{BL}$	-	5.2	5.8	W	3
Operating Frequency	$f_{BL}$	40	60	80	kHz	4
Discharge Stabilization Time	$T_s$	-	-	3	Min	5
Life Time		20,000	-	-	Hrs	6
Established Starting Voltage	Vs	at 25	-	1,500	$V_{RMS}$	7
		at -10	-	2,200	$V_{RMS}$	

- The used lamp current is the lamp typical current.
- The typical operating current is 6.5 mArms for the typical surface luminance ( $L_{WH}$ ) in optical characteristics.
- The lamp power consumption shown above does not include loss of external inverter.

The used lamp current is the lamp typical current. ( $P_{BL} = V_{BL} \times I_{BL}$ )

- The output of the inverter must have symmetrical(negative and positive) voltage waveform and symmetrical current waveform.(Asymmetrical ratio is less than 10%) Please do not use the inverter which has asymmetrical voltage and asymmetrical current and spike wave.  
Lamp frequency may produce interface with horizontal synchronous frequency and as a result this may cause beat on the display. Therefore lamp frequency shall be as away possible from the horizontal synchronous frequency and from its harmonics in order to prevent interference.

- Define the brightness of the lamp after being lighted for 5 minutes as 100%,  $T_s$  is the time required for the brightness of the center of the lamp to be not less than 95%.
- The life time is determined as the time at which brightness of lamp is 50% compare to that of initial value at the typical lamp current
- The voltage above  $V_s$  should be applied to the lamp for more than 1 second for start-up, Otherwise, the lamp may not be turned on, The used lamp current is the lamp typical current.
- Requirements for a system inverter design, which is intended to have a better display performance, a better power efficiency and a more reliable lamp, are following.

It shall help increase the lamp lifetime and reduce leakage current.

a. The asymmetry rate of the inverter waveform should be less than 10%.

b. The distortion rate of the waveform should be within  $2 \pm 10\%$ .

\* Inverter output waveform had better be more similar to ideal sine wave.

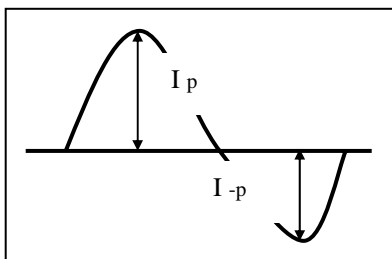

\* Asymmetry rate:

$$\frac{|I_p - I_{-p}|}{I_{RMS}} * 100\%$$

\* Distortion rate

$$I_p \text{ (or } I_{-p}) / I_{RMS}$$

Do not attach a conducting tape to lamp connecting wire.

If the lamp wire attach to a conducting tape, TFT-LCD Module has a low luminance and the inverter has abnormal action. Because leakage current is occurred between lamp wire and conducting tape.

## Product Specification

### 3-2. Interface (Input Terminal)

This LCD employs two interface connections, a 60 pin connector is used for the module electronics interface and the other connector is used for the integral backlight system.

**Table 4. TFT-LCD Panel Driving Part**

Pin No.	Symbol	Description	Pin No.	Symbol	Description
1	POL	Polarity selection	31	GND	Power ground
2	STVD	Vertical start pulse input when U/D=H	32	G5	Green data(MSB)
3	OEV	Output enable	33	G4	Green data
4	CKV	Vertical clock	34	G3	Green data
5	STVU	Vertical start pulse input when U/D=L	35	G2	Green data
6	GND	Power ground	36	G1	Green data
7	EDGSL	Select rising edge or falling edge	37	G0	Green data(LSB)
8	VCC	Power supply for digital circuit	38	STHL	Horizontal start pulse input when R/L=L
9	V9	Gamma voltage level 9	39	REV	Control signal are inverted or not
10	VGL	Gate OFF voltage	40	GND	Power ground
11	V2	Gamma voltage level 2	41	DCLK	Sample clock
12	VGH	Gate ON voltage	42	VCC	Power supply for digital circuit
13	V6	Gamma voltage level 6	43	STHR	Horizontal start pulse input when R/L=H
14	U/D	Up/down selection	44	LD	Latch the polarity of outputs and switches the new data to outputs
15	VCOM	Common voltage	45	B5	Blue data(MSB)
16	GND	Power ground	46	B4	Blue data
17	AVDD	Power supply for analog circuit	47	B3	Blue data
18	V14	Gamma voltage level 14	48	B2	Blue data
19	V11	Gamma voltage level 11	49	B1	Blue data
20	V8	Gamma voltage level 8	50	B0	Blue data(LSB)
21	V5	Gamma voltage level 5	51	R/L	Right/Left selection
22	V3	Gamma voltage level 3	52	V1	Gamma voltage level 1
23	GND	Power ground	53	V4	Gamma voltage level 4
24	R5	Red data(MSB)	54	V7	Gamma voltage level 7
25	R4	Red data	55	V10	Gamma voltage level 10
26	R3	Red data	56	V12	Gamma voltage level 12
27	R2	Red data	57	V13	Gamma voltage level 13
28	R1	Red data	58	AVDD	Power supply for analog circuit
29	R0	Red data(LSB)	59	GND	Power ground
30	GND	Power ground	60	VCOM	Common voltage

\*\*The matching connector part number is FH19SC-30S-0.5SH(Bottom Contact Type, 0.5mm-Pitch) manufactured by Hirose or equivalent.



**Product Specification**

The backlight interface connector is a model BHSR-02VS-1, manufactured by JST or Compatible.  
The mating connector part number is SM02B-BHSS-1 or equivalent.

**Table 5. BACKLIGHT CONNECTOR PIN CONFIGURATION (CN2)**

Pin	Symbol	Description	Wire Color
1	HV	Power supply for lamp (High voltage side)	Pink
2	LV	Power supply for lamp (Low voltage side)	White

**Product Specification**
**3-3. Signal Timing Specifications**
**Table 6. Timing Characteristics of input signals**

Parameter		Symbol	Min	Typ	Max	Unit	condition
S O U R C E	CLK Frequency	fclk	-	50	55	MHz	EDGSL='0'
		fclk	-	25	27.5	MHz	EDGSL='1'
	CLK pulse width	Tcw	40%	-	60%	Tcph	
	Data set-up time	Tsu	4	-	-	ns	
	Data hold time	Thd	2	-	-	ns	
	Propagation delay of DIO2/1	Tphl	6	10	15	ns	CL=25pF ( Output )
	Time that the last data to LD	Tld	1	-	-	Tcph	
	Pulse width of LD	Twld	2	-	-	Tcph	
	Time that LD to DIO 1/2	Tlds	5	-	-	Tcph	
	POL Set-up time	Tpsu	6	-	-	ns	POL to LD
	POL hold time	Tphd	6	-	-	ns	POL to LD
	Output stable time	Tst	-	-	9	ns	
	Repair output delay stable time	Tst1	-	-	20	us	
	G A T E	GSC Frequency	fclk	-	-	200	KHz
GSC Rise Time		trck	-	-	100	ns	
GSC Falling Time		tfck	-	-	100	ns	
GSC Pulse Width		pwclk	500	-	-	ns	
GSP1/2 Setup Time		tsu	200	-	-	ns	
GSP1/2 Hold Time		thd	300	-	-	ns	
GOE Pulse Width		twcl	1	-	-	us	

Product Specification

3-4. Timing Diagram

Source D-IC Timing Diagram

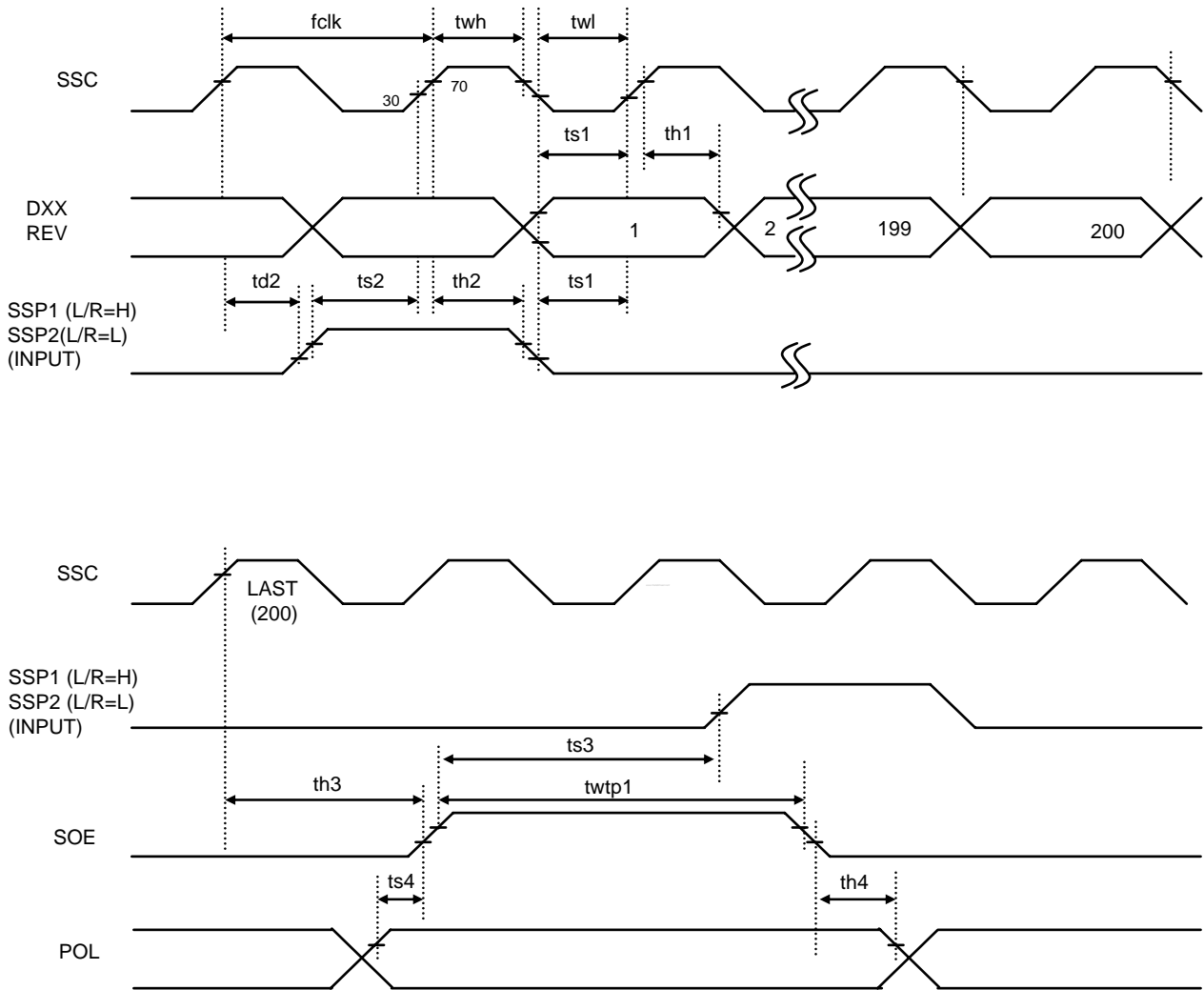

Product Specification

Gate D-IC Timing Diagram

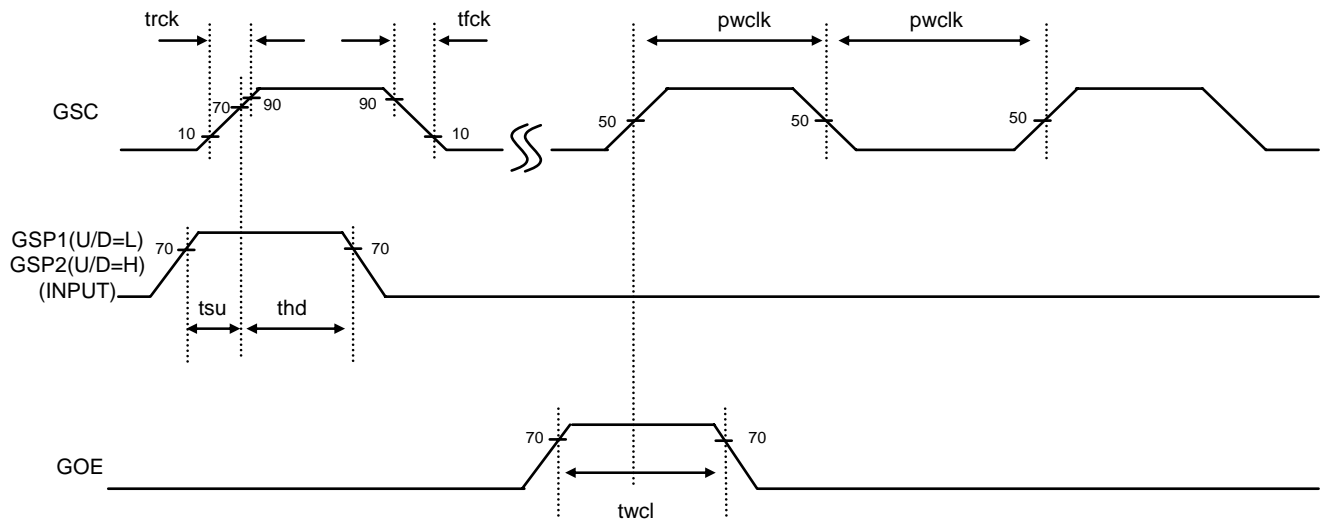

**Product Specification**
**3-5. Detail Description of Pin Functions**

1. U\_D is used as input pin for selecting the shifting direction of bi-directional shift register.

U_D	Output Shift	STV Input Pin
H	Up to Down	STVD
L	Down to Up	STVU

2. R\_L is used as input pin for the horizontal scanning direction. If R\_L is H, STHR is the Input Pin for the Source Start Pulse(STH=SSP). Otherwise(If R\_L is L), STHL is the Input Pin for the SSP.

R_L	Scanning Direction	STH Input Pin
H	Form Left to Right	STHR
L	From Right to Left	STHL

**3-6. Recommended Gamma Correction Voltage [V1 to V14]**

(AVDD=9.32V)

Symbol	Values(Typ)	Unit	Remark
V1	(8.35)	V	[Note 3-3]
V2	(Open)		
V3	(Open)		
V4	(6.59)		
V5	(Open)		
V6	(Open)		
V7	(5.32)		
V8	(3.60)		
V9	(Open)		
V10	(Open)		
V11	(2.37)		
V12	(Open)		
V13	(Open)		
V14	(0.63)		

[Note 3-3] Be sure to maintain the voltage relationships of  
 $AVDD > V1 > V2 > V3 > V4 > V5 > V6 > V7 ; V8 > V9 > V10 > V11 > V12 > V13 > V14 > GND+0.1V$

**Product Specification**

**4. Optical Specifications**

Optical characteristics are determined after the unit has been 'ON' and stable for approximately 30 minutes in a dark environment at 25°C. The values specified are at an approximate distance 50cm from the LCD surface at a viewing angle of  $\Phi$  and  $\Theta$  equal to 0°.

FIG. 1 presents additional information concerning the measurement equipment and method.

**FIG. 1 Optical Characteristic Measurement Equipment and Method**

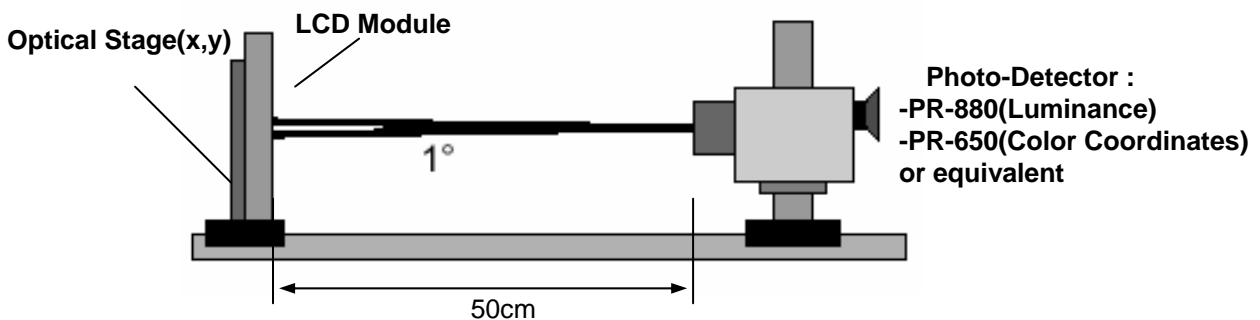

**Table 9. OPTICAL CHARACTERISTICS**

Ta=25°C, VCC=3.3V, fv=60Hz, fCLK= 50MHZ, IBL = 6.5 mA<sub>RMS</sub>

Parameter	Symbol	Values			Units	Remark
		Min	Typ	Max		
Contrast Ratio	CR	300	400	-		[Note 4-1]
Surface Luminance, white	L <sub>WH</sub>	200	250	-	cd/m <sup>2</sup>	[Note 4-2]
Luminance Variation	$\delta_{\text{WHITE}}$	-	1.25	1.4		[Note 4-3]
Response Time						[Note 4-4]
: Rise Time	T <sub>R</sub>	-	6	20	ms	
: Decay Time	T <sub>D</sub>	-	19	30	ms	
Color Coordinates						[Note 4-2]
: RED	Rx	0.571	0.601	0.631		Reference
:	Ry	0.301	0.331	0.361		
: GREEN	Gx	0.277	0.307	0.337		
:	Gy	0.551	0.581	0.601		
: BLUE	Bx	0.119	0.149	0.179		
:	By	0.093	0.123	0.153		
: WHITE	Wx	0.270	0.300	0.330		
:	Wy	0.300	0.330	0.360		
Viewing Angle						[Note 4-5]
: x axis, right( $\Phi=0^\circ$ )	$\Theta_r$	55	65	-	degree	
: x axis, left ( $\Phi=180^\circ$ )	$\Theta_l$	55	65	-	degree	
: y axis, up ( $\Phi=90^\circ$ )	$\Theta_u$	45	55	-	degree	
: y axis, down ( $\Phi=270^\circ$ )	$\Theta_d$	40	50	-	degree	

## Product Specification

[Note 4-1] Contrast Ratio(CR) is defined mathematically as

$$\text{Contrast Ratio} = \frac{\text{Surface Luminance with all white pixels}}{\text{Surface Luminance with all black pixels}}$$

[Note 4-2] Surface luminance is measured at the center point(L<sub>1</sub>) of the LCD with all pixels displaying white at the distance of 50cm by PR-880. Color Coordinates are measured at the center point(L<sub>1</sub>) of the LCD with all pixels displaying red, green, blue and white at the distance of 50cm by PR-650. For more information, refer to the FIG 1 and FIG 2.

[Note 4-3] Luminance % uniformity is measured for 9 point For more information see FIG 2.  
 WHITE = Maximum(L<sub>1</sub>,L<sub>2</sub>, ..... L<sub>9</sub>) ÷ Minimum(L<sub>1</sub>,L<sub>2</sub>, ..... L<sub>9</sub>)

[Note 4-4] Response time is the time required for the display to transition from white to black (Rise Time, Tr<sub>R</sub>) and from black to white(Decay Time, Tr<sub>D</sub>). For additional information see FIG 3.

[Note 4-5] Viewing angle is the angle at which the contrast ratio is greater than 10. The angles are determined for the horizontal or x axis and the vertical or y axis with respect to the z axis which is normal to the LCD surface. For more information see FIG 4.

Product Specification

FIG. 2 Luminance

<measuring point for surface luminance & measuring point for luminance variation>

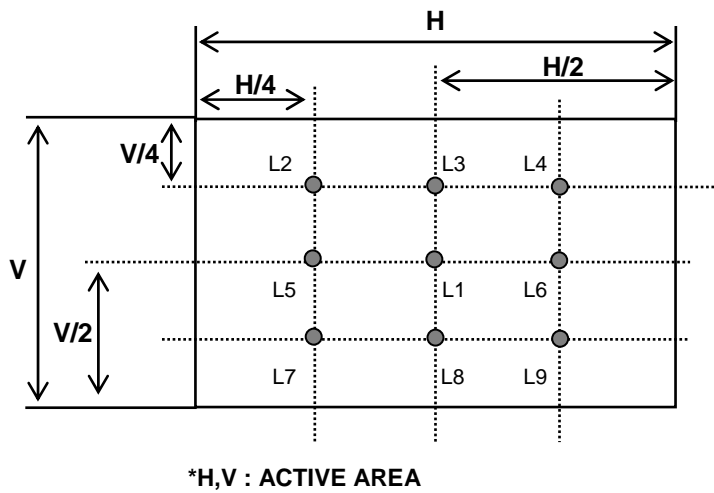
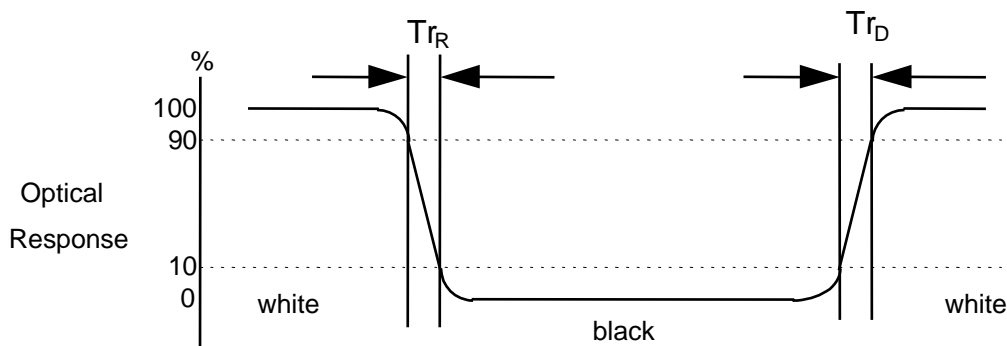

FIG. 3 Response Time

The response time is defined as the following figure and shall be measured by switching the input signal for "black" and "white".





Product Specification

FIG. 4 Viewing angle

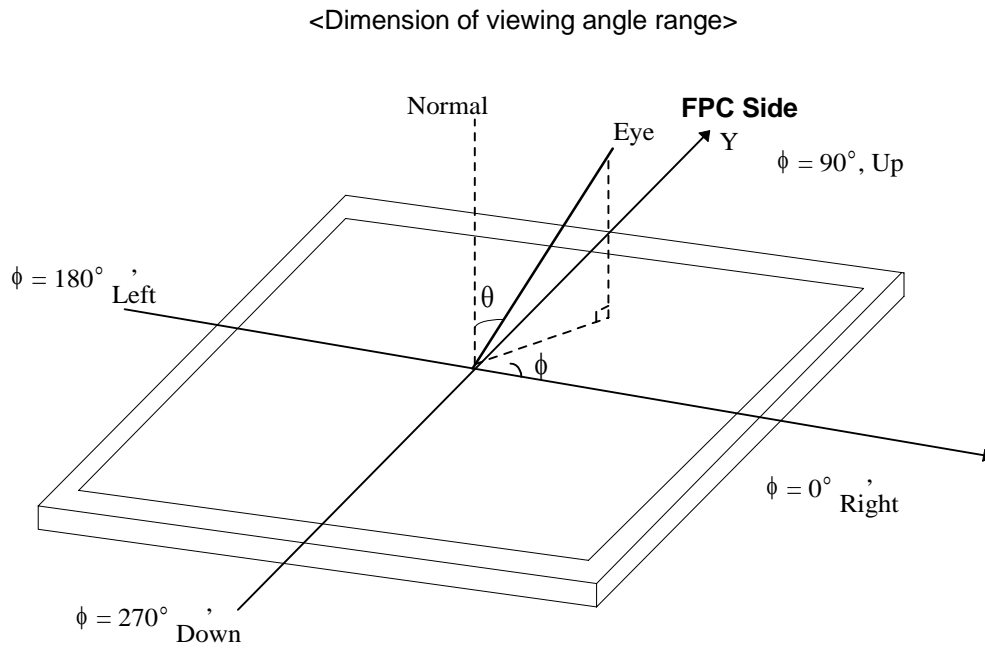

**Product Specification**
**5. Mechanical Characteristics**

The contents provide general mechanical characteristics for the model LB104S02. In addition the figures in the next page are detailed mechanical drawing of the LCD.

Outline Dimension	Horizontal	234.7 mm(Typ)
	Vertical	178.6 mm(Typ)
	Depth	6.8 mm (Typ.)
Bezel Area	Horizontal	214.5 mm (Typ.)
	Vertical	161 mm (Typ.)
Active Display Area	Horizontal	211.2 mm (Typ.)
	Vertical	158.4 mm (Typ.)
Weight	420 g(Typ.) / 450 g ( Max.)	
Surface Treatment	Anti-glare treatment of the front polarizer	

Product Specification

<FRONT VIEW>

Unit:[mm], General tolerance:  $\pm 0.3\text{mm}$

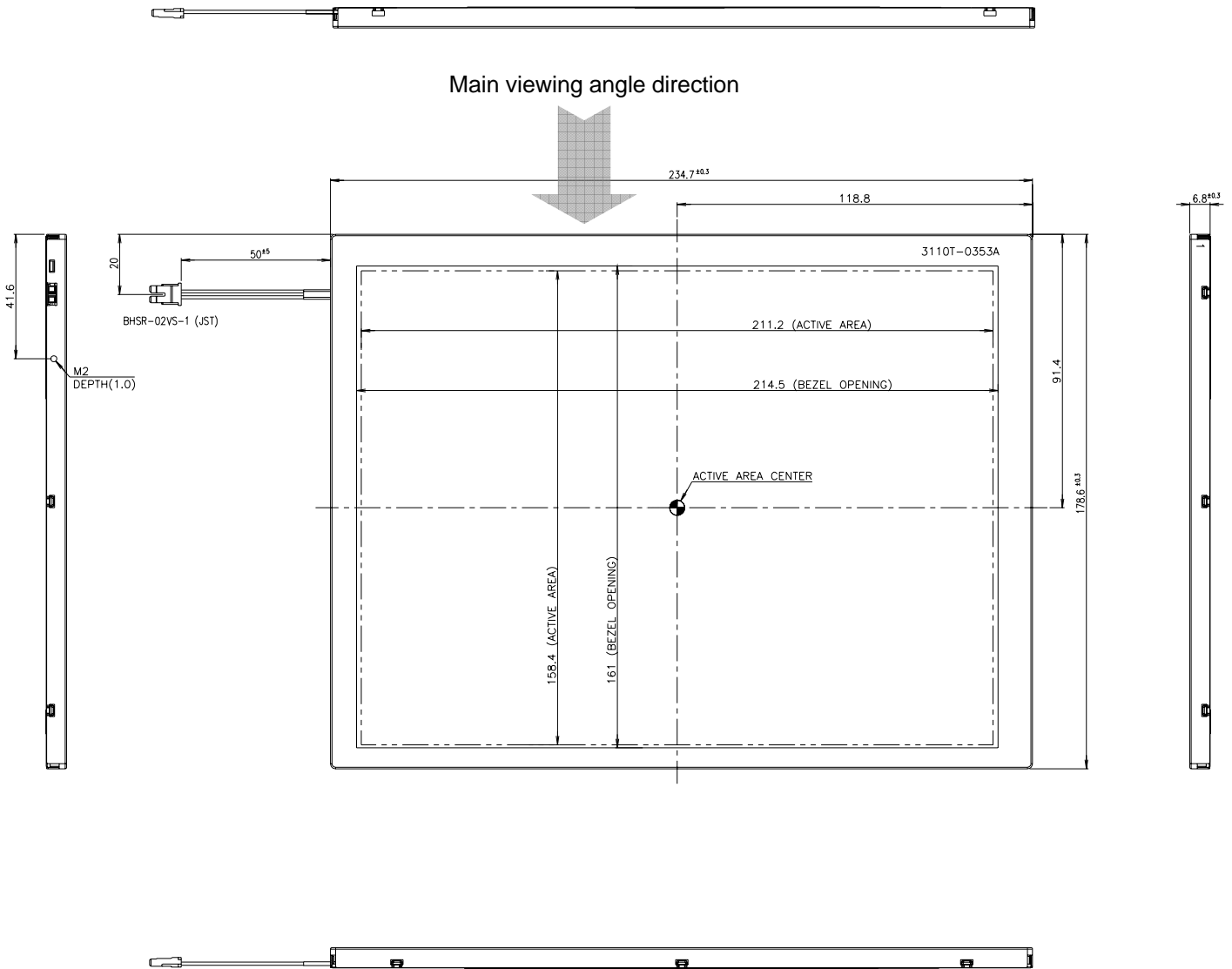

Product Specification

<REAR VIEW>

Unit:[mm], General tolerance:  $\pm 0.3$ mm

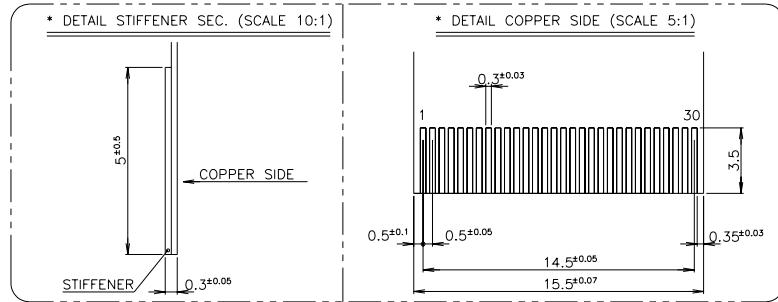

Main viewing angle direction

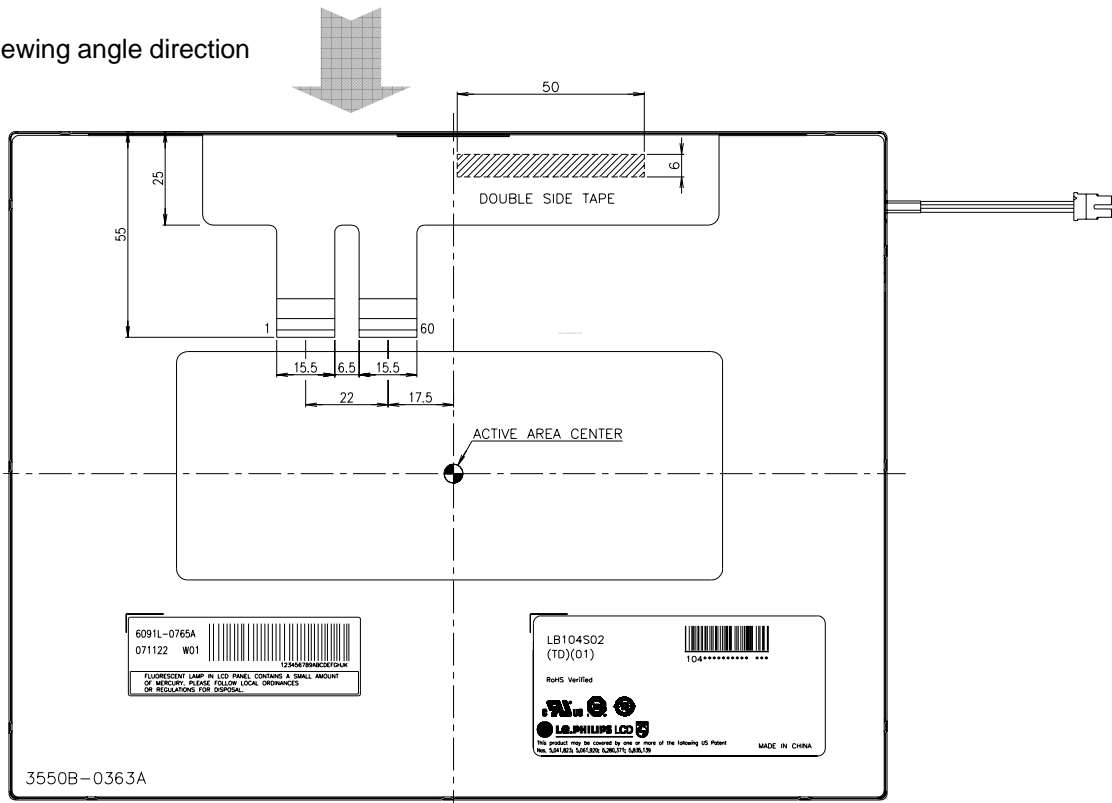

**Product Specification**
**6. Reliability**

No.	Test Items	Test Condition	Remark
1	High Temperature Storage Test	T <sub>a</sub> =70 240h	[Note 6-1,2,3]
2	Low Temperature Storage Test	T <sub>a</sub> =-20 240h	[Note 6-1,2,3]
3	High Temperature Operation Test	T <sub>p</sub> =60 240h	[Note 6-1,2,3]
4	Low Temperature Operation Test	T <sub>a</sub> =-10 240h	[Note 6-1,2,3]
5	High Temperature and High Humidity Operation Test	T <sub>a</sub> =50 80%RH 240h	[Note 6-1,2,3]
6	Electro Static Discharge Test	-Panel Surface/Top_Case : 150pF, 150 (Air : ±15kV , Contact : ±8kV ) -FPC input terminal : 100pF ±200V 0	
7	Shock Test (non-operating)	Half sine wave, 80G, 11ms 3 times shock of each six faces	
8	Vibration Test (non-operating)	Sine wave, 10 ~ 500 ~ 10Hz, 1.5G, 0.37oct/min 3 axis, 1hour/axis	
9	Thermal Shock Test	-10 (0.5h) ~ 60 (0.5h) / 100 cycles	

[Note 6-1] T<sub>a</sub> = Ambient Temperature, T<sub>p</sub> = Panel Surface Temperature

[Note 6-2] In the Reliability Test, Confirm performance after leaving in room temp.

[Note 6-3] In the standard condition, there shall be no practical problems that may affect the display function.

{ Result Evaluation Criteria }

1. Evaluation should be tested after storage at room temperature for 24 hours.
2. There should be no change which might affect the practical display function when the display test quality test is conducted under normal operating condition.

**Product Specification****7. International Standards****7-1. Safety**

- a) UL 60950, Third Edition, Underwriters Laboratories, Inc., Dated Dec. 11, 2000.  
Standard for Safety of Information Technology Equipment, Including Electrical Business Equipment.
- b) CAN/CSA C22.2, No. 60950, Third Edition, Canadian Standards Association, Dec. 1, 2000.  
Standard for Safety of Information Technology Equipment, Including Electrical Business Equipment.
- c) EN 60950 : 2000, Third Edition  
IEC 60950 : 1999, Third Edition  
European Committee for Electrotechnical Standardization(CENELEC)  
EUROPEAN STANDARD for Safety of Information Technology Equipment Including Electrical Business Equipment.

**7-2. EMC**

- a) ANSI C63.4 "Methods of Measurement of Radio-Noise Emissions from Low-Voltage Electrical and Electrical Equipment in the Range of 9kHz to 40GHz. "American National Standards Institute(ANSI), 1992
- b) C.I.S.P.R. "Limits and Methods of Measurement of Radio Interface Characteristics of Information Technology Equipment." International Special Committee on Radio Interference.
- c) EN 55022 "Limits and Methods of Measurement of Radio Interface Characteristics of Information Technology Equipment." European Committee for Electrotechnical Standardization.(CENELEC), 1998 ( Including A1: 2000 )

**Product Specification**

## 8. Packing

### 8-1. Designation of Lot Mark

a) Lot Mark

A	B	C	D	E	F	G	H	I	J	K	L	M
---	---	---	---	---	---	---	---	---	---	---	---	---

A,B,C : SIZE(INCH)  
E : MONTH

D : YEAR  
F ~ M : SERIAL NO.

Note

1. YEAR

Year	2001	2002	2003	2004	2005	2006	2007	2008	2009	2010
Mark	1	2	3	4	5	6	7	8	9	0

2. MONTH

Month	Jan	Feb	Mar	Apr	May	Jun	Jul	Aug	Sep	Oct	Nov	Dec
Mark	1	2	3	4	5	6	7	8	9	A	B	C

b) Location of Lot Mark

Serial No. is printed on the label. The label is attached to the backside of the LCD module.  
This is subject to change without prior notice.

### 8-2. Packing Form

a) Package quantity in one box : 20 pcs

b) Box Size(mm) : 425x246x310

## Product Specification

### 9. PRECAUTIONS

Please pay attention to the followings when you use this TFT LCD module.

#### 9-1. MOUNTING PRECAUTIONS

- (1) You must mount a module using holes arranged in four corners or four sides.
- (2) You should consider the mounting structure so that uneven force (ex. Twisted stress) is not applied to the module. And the case on which a module is mounted should have sufficient strength so that external force is not transmitted directly to the module.
- (3) Please attach the surface transparent protective plate to the surface in order to protect the polarizer. Transparent protective plate should have sufficient strength in order to resist external force.
- (4) You should adopt radiation structure to satisfy the temperature specification.
- (5) Acetic acid type and chlorine type materials for the cover case are not desirable because the former generates corrosive gas of attacking the polarizer at high temperature and the latter causes circuit break by electro-chemical reaction.
- (6) Do not touch, push or rub the exposed polarizers with glass, tweezers or anything harder than HB pencil lead. And please do not rub with dust clothes with chemical treatment. Do not touch the surface of polarizer for bare hand or greasy cloth.(Some cosmetics are detrimental to the polarizer.)
- (7) When the surface becomes dusty, please wipe gently with absorbent cotton or other soft materials like chamois soaks with petroleum benzene. Normal-hexane is recommended for cleaning the adhesives used to attach front / rear polarizers. Do not use acetone, toluene and alcohol because they cause chemical damage to the polarizer.
- (8) Wipe off saliva or water drops as soon as possible. Their long time contact with polarizer causes deformations and color fading.
- (9) Do not open the case because inside circuits do not have sufficient strength.

#### 9-2. OPERATING PRECAUTIONS

- (1) The spike noise causes the mis-operation of circuits. It should be lower than following voltage :  
 $V = \pm 200\text{mV}$ (Over and under shoot voltage)
- (2) Response time depends on the temperature.(In lower temperature, it becomes longer.)
- (3) Brightness depends on the temperature. (In lower temperature, it becomes lower.)  
And in lower temperature, response time(required time that brightness is stable after turned on) becomes longer.
- (4) Be careful for condensation at sudden temperature change. Condensation makes damage to polarizer or electrical contacted parts. And after fading condensation, smear or spot will occur.
- (5) When fixed patterns are displayed for a long time, remnant image is likely to occur.
- (6) Module has high frequency circuits. Sufficient suppression to the electromagnetic interference shall be done by system manufacturers. Grounding and shielding methods may be important to minimize the interference.
- (7) This module is not designed to attach TSP(touch screen panels). If TSP is applied, LPL can't guarantee the 'Ripple' related problems.



**Product Specification****9-3. ELECTROSTATIC DISCHARGE CONTROL**

Since a module is composed of electronic circuits, it is not strong to electrostatic discharge. Make certain that treatment persons are connected to ground through wrist band etc. And don't touch interface pin directly.

**9-4. PRECAUTIONS FOR STRONG LIGHT EXPOSURE**

Strong light exposure causes degradation of polarizer and color filter.

**9-5. STORAGE**

When storing modules as spares for a long time, the following precautions are necessary.

- (1) Store them in a dark place. Do not expose the module to sunlight or fluorescent light. Keep the temperature between 5°C and 35°C at normal humidity.
- (2) The polarizer surface should not come in contact with any other object.  
It is recommended that they be stored in the container in which they were shipped.

**9-6. HANDLING PRECAUTIONS FOR PROTECTION FILM**

- (1) When the protection film is peeled off, static electricity is generated between the film and polarizer. This should be peeled off slowly and carefully by people who are electrically grounded and with well ion-blown equipment or in such a condition, etc.
- (2) The protection film is attached to the polarizer with a small amount of glue. If some stress is applied to rub the protection film against the polarizer during the time you peel off the film, the glue is apt to remain on the polarizer.  
Please carefully peel off the protection film without rubbing it against the polarizer.
- (3) When the module with protection film attached is stored for a long time, sometimes there remains a very small amount of glue still on the polarizer after the protection film is peeled off.
- (4) You can remove the glue easily. When the glue remains on the polarizer surface or its vestige is recognized, please wipe them off with absorbent cotton waste or other soft material like chamois soaked with normal-hexane.