

1 A REGULATOR (Operating Voltage up to 16V)

No.EA-183-090206

OUTLINE

The R1190x series are a low supply current voltage regulator with high output voltage accuracy. The maximum operating voltage is 16V. Each of these ICs consists of a voltage reference unit, an error amplifier, a resistor-net for voltage setting, as a short current protection, a peak current protection, a thermal shutdown, an inrush current limit and a chip enable circuit. The wide input voltage range (Max. 16V). Additionally, the output voltage is fixed internally, in the range from 2.0V to 12.0V by the 0.1V steps. The supply current of R1190x series is excellent (Typ.150 μ A) moreover R1190x series has the standby mode (Typ.0.1 μ A) by the chip enable function.

Since the package for these ICs are TO-252-5-P2, SOT-89-5 and HSOP-6J with high power dissipation, high density mounting of the ICs on boards is possible.

FEATURES

- Wide Range of Operating VoltageMin.16V
- High Output Voltage Accuracy $\pm 1.5\%$
- Output VoltageStepwise setting with a step of 0.1V in the range of 2.0V to 12.0V is possible
- Supply CurrentTyp.150 μ A ($V_{IN}=V_{OUT}+2.0V$, 3.3V output)
- Extremely Low Standby CurrentTyp.0.1 μ A
- Output CurrentMin. 1A ($V_{IN}=V_{OUT}+2.0V$, 3.3V output)
- PackagesTO-252-5-P2, HSOP-6J, SOT-89-5,

Built-in functions

- Peak Current Protection Circuit
- Short Current Protection Circuit
- Thermal Shutdown Circuit
- Inrush Current Limit Circuit

Others

- The Delay Pin for setting Inrush Current Limit Time.
- Operating Temperature Range-40°C to 85°C

APPLICATIONS

- Power source for digital home appliances
- Power source for audio visual equipments

BLOCK DIAGRAMS

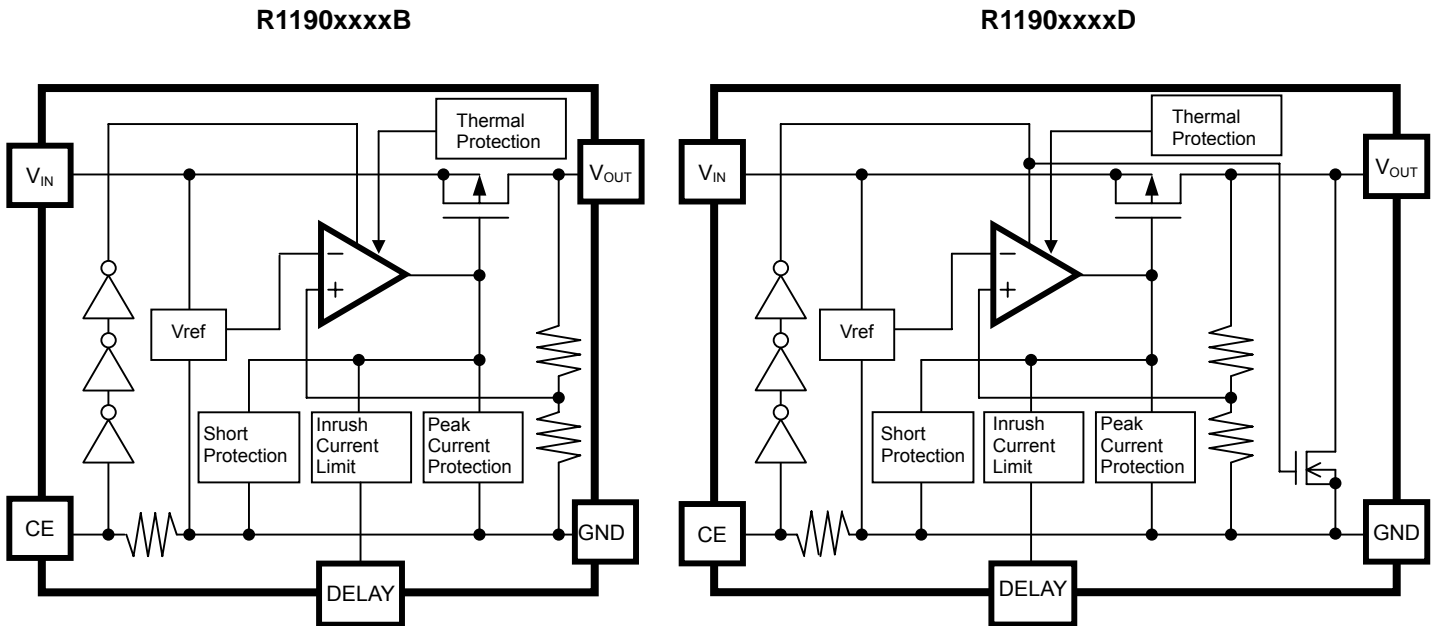

SELECTION GUIDE

The output voltage, version, package and the taping type for the ICs can be selected at the user's request. The selection can be made with designating the part number as shown below;

R1190x xxx x-xx-xx ←Part Number
 ↑ ↑ ↑ ↑ ↑
 a b c d e

Code	Contents
a	Designation of Package Type: H : SOT-89-5 S : HSOP-6J J : TO-252-5-P2
b	Setting Output Voltage (V_{OUT}): Stepwise setting with 0.1V increment in the range from 2.0V to 12.0V
c	Designation of Active Type: B: active high type* D: active high, with auto discharge*
d	Designation of Taping Type (Refer to Taping Specifications) T1: SOT-89-5, TO-252-5-P2 E2: HSOP-6J
e	Designation of composition of pin plating: -F: Lead free solder plating

*When the mode is into standby with CE signal, auto-discharge transistor turns on, and it makes the turn-off speed faster than normal type.

PIN CONFIGURATION

TO-252-5-P2

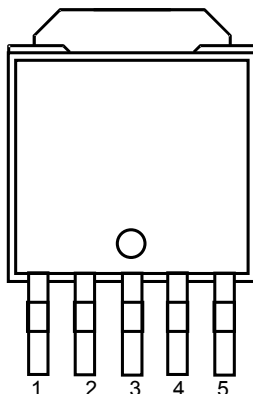

SOT-89-5

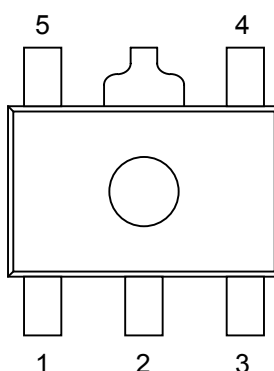

HSOP-6J

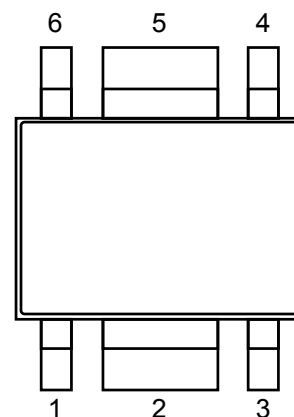

PIN DESCRIPTIONS

R1190J: TO-252-5-P2

Pin No.	Symbol	Description
1	DELAY	Delay Pin (for setting Inrush Current Limit Time)
2	V_{DD}	Input Pin
3	GND	Ground Pin
4	V_{OUT}	Output Pin
5	CE	Chip Enable Pin ("H" Active)

R1190S: HSOP-6J

Pin No.	Symbol	Description
1	V_{OUT}	Output Pin
2	GND	Ground Pin
3	CE	Chip Enable Pin ("H" Active)
4	DELAY	Delay Pin (for setting Inrush Current Limit Time)
5	GND	Ground Pin
6	V_{DD}	Input Pin

R1190H: SOT-89-5

Pin No.	Symbol	Description
1	V_{OUT}	Output Pin
2	GND	Ground Pin
3	CE	Chip Enable Pin ("H" Active)
4	DELAY	Delay Pin (for setting Inrush Current Limit Time)
5	V_{DD}	Input Pin

ABSOLUTE MAXIMUM RATINGS

Symbol	Item	Rating		Unit
V_{IN}	Input Voltage	-0.3 to 18		V
V_{CE}	Input Voltage (CE Pin)	$-0.3 \text{ to } V_{IN} + 0.3 \leq 18$		V
V_{OUT}	Output Voltage	$-0.3 \text{ to } V_{IN} + 0.3 \leq 18$		V
I_{OUT}	Output Current	1500		mA
P_D	Power Dissipation *	TO-252-5-P2	1900	mW
		HSOP-6J	1700	
		SOT-89-5	900	
T_a	Ambient Temperature Range	- 40 to + 85		°C
T_{stg}	Storage Temperature Range	- 55 to +150		°C

*For Power Dissipation, please refer to PACKAGE INFORMATION (p.10~) to be described.

ABSOLUTE MAXIMUM RATINGS

Electronic and mechanical stress momentarily exceeded absolute maximum ratings may cause the permanent damages and may degrade the life time and safety for both device and system using the device in the field. The functional operation at or over these absolute maximum ratings is not assured.

ELECTRICAL CHARACTERISTICS

$V_{IN}=CE=Set V_{OUT} + 2.0V$, $C_{IN}=4.7\mu F$, $C_{OUT}=4.7\mu F$, $I_{OUT}=1mA$ unless otherwise noted.

□ values indicate $-40^{\circ}C \leq Ta \leq 85^{\circ}C$, unless otherwise noted.

R1190xxxx

Ta=25°C

Symbol	Item	Conditions	MIN.	TYP.	MAX.	Unit	
V_{OUT}	Output Voltage	$I_{OUT}=1mA$	Ta=25°C	x 0.985		x 1.015	V
			$-40^{\circ}C \leq Ta \leq 85^{\circ}C$	□ 0.973		□ 1.027	
I_{OUT}	Output Current	Please see the following table *(1)					
$\frac{\Delta V_{OUT}}{\Delta I_{OUT}}$	Load Regulation	Please see the following table *(2)					
V_{DIF}	Dropout Voltage	Please see the following table *(3)					
I_{SS}	Supply Current	$I_{OUT}=0mA$		150	□ 220	μA	
Istandby	Supply Current (CE Off State)	$V_{IN}=16V$ $V_{CE}=0V$		0.1	1.0	μA	
$\frac{\Delta V_{OUT}}{\Delta V_{IN}}$	Line Regulation	$V_{OUT}+0.5V(\text{Min. } 3.5V) \leq V_{IN} \leq 16V$ $I_{OUT}=1mA$		0.02	□ 0.10	%/V	
RR	Ripple Rejection	f=1kHz $I_{OUT}=100mA$		60		dB	
V_{IN}	Input Voltage		□ 3.5		□ 16	V	
$\frac{\Delta V_{OUT}}{\Delta Ta}$	Output Voltage Temperature Coefficient	$I_{OUT}=1mA$ $-40^{\circ}C \leq Ta \leq 85^{\circ}C$		±100		ppm/°C	
I_{LIM}	Short Current Limit	$V_{OUT}=0V$		300		mA	
V_{CEH}	CE Input Voltage "H"		□ 1.6		V_{IN}	V	
V_{CEL}	CE Input Voltage "L"		0.0		□ 0.6	V	
T_{TSD}	Thermal Shutdown Temperature	Junction Temperature		150		°C	
T_{TSR}	Thermal Shutdown Released Temperature	Junction Temperature		130		°C	
R_{LOW}	Nch On Resistance for Auto Discharge (D Version Only)	$V_{IN}=5.0V$ $V_{CE}=0V$ $V_{OUT}=0.3V$		100		Ω	

The specification in □ is checked and guaranteed by design engineering.

All of units are tested and specified under pulse load conditions such that $T_j \approx Ta = 25^{\circ}C$ except for Ripple Rejection, Output Voltage Temperature Coefficient items, Thermal Shutdown, Load Regulation at $0.1mA \leq V_{OUT} \leq 600mA (2.0 \leq V_{OUT} < 2.5V)$ and at $0.1mA \leq V_{OUT} \leq 700mA (2.5 \leq V_{OUT} < 3.3V)$ and at $0.1mA \leq V_{OUT} \leq 1000mA (3.3 \leq V_{OUT} \leq 12.0V)$, Dropout Voltage at $I_{OUT}=600mA (2.0 \leq V_{OUT} < 2.5V)$ and at $I_{OUT}=700mA (2.5 \leq V_{OUT} < 3.3V)$ and at $I_{OUT}=1000mA (3.3 \leq V_{OUT} \leq 12.0V)$

RECOMMENDED OPERATING CONDITIONS (ELECTRICAL CHARACTERISTICS)

All of electronic equipment should be designed that the mounted semiconductor devices operate within the recommended operating conditions. The semiconductor devices cannot operate normally over the recommended operating conditions, even if when they are used over such conditions by momentary electronic noise or surge. And the semiconductor devices may receive serious damage when they continue to operate over the recommended operating conditions.

***(1) Output Current**

Output Voltage V_{OUT} (V)	Output Current I_{OUT} (mA)	
	Condition	Min.
$2.0 \leq V_{OUT} < 2.5$	$V_{IN} + V_{OUT} + 2.3V$	600
$2.5 \leq V_{OUT} < 3.3$		700
$3.3 \leq V_{OUT} \leq 12.0$		1000

***(2) Load Regulation**

Output Voltage V_{OUT} (V)	Load Regulation $\Delta V_{OUT} / \Delta I_{OUT}$ (mV)			
	Condition	Typ.	Max.	
$2.0 \leq V_{OUT} < 2.5$	$V_{IN} + V_{OUT} + 2.3V$	$1mA \leq I_{OUT} \leq 200mA$	20	60
		$1mA \leq I_{OUT} \leq 600mA$	80	180
$2.5 \leq V_{OUT} < 3.3$	$V_{IN} + V_{OUT} + 2.3V$	$1mA \leq I_{OUT} \leq 200mA$	20	60
		$1mA \leq I_{OUT} \leq 700mA$	90	200
$3.3 \leq V_{OUT} < 5.0$	$V_{IN} + V_{OUT} + 2.3V$	$1mA \leq I_{OUT} \leq 200mA$	20	60
		$1mA \leq I_{OUT} \leq 1000mA$	120	230
$5.0 \leq V_{OUT} \leq 12.0$	$V_{IN} + V_{OUT} + 2.3V$	$1mA \leq I_{OUT} \leq 200mA$	40	100
		$1mA \leq I_{OUT} \leq 1000mA$	130	250

***(3) Dropout Voltage**

Output Voltage V_{OUT} (V)	Dropout Voltage V_{DIF} (V)			Output Voltage V_{OUT} (V)	Dropout Voltage V_{DIF} (V)			
	Condition	Typ.	Max.		Condition	Typ.	Max.	
2.0	$I_{OUT} = 200mA$	/	1.5	$2.0 \leq V_{OUT} < 2.5$	$I_{OUT} = 600mA$	1.6	2.2	
2.1			1.4					
2.2			1.3					
2.3			1.2					
2.4			1.1					
2.5			1.0	$2.5 \leq V_{OUT} < 3.3$	$I_{OUT} = 700mA$	1.5	2.15	
2.6			0.9					
2.7			0.8					
$2.8 \leq V_{OUT} < 3.1$			0.7	$3.3 \leq V_{OUT} \leq 12.0$	$I_{OUT} = 1000mA$	1.6	2.3	
$3.1 \leq V_{OUT} < 3.3$			0.4					0.7
$3.3 \leq V_{OUT} < 4.0$			0.3					0.53
$4.0 \leq V_{OUT} < 5.0$			0.25					0.42
$5.0 \leq V_{OUT} < 9.0$			0.19					0.31
$9.0 \leq V_{OUT} \leq 12.0$	0.1	0.18	0.8	1.30				

TEST CIRCUITS

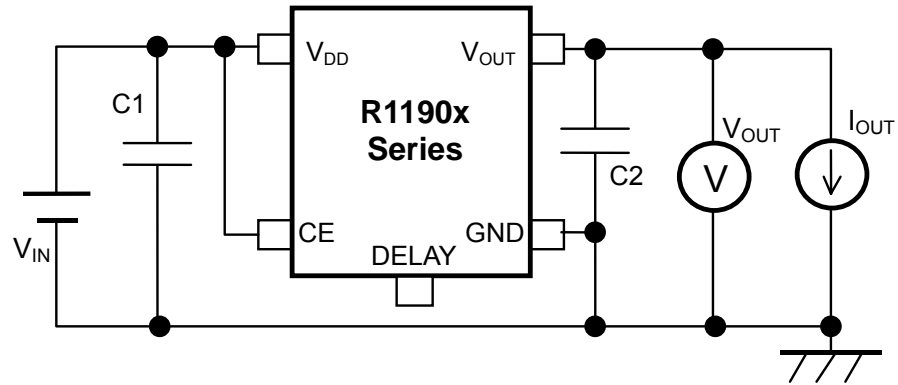

Fig.1 Basic Test Circuit

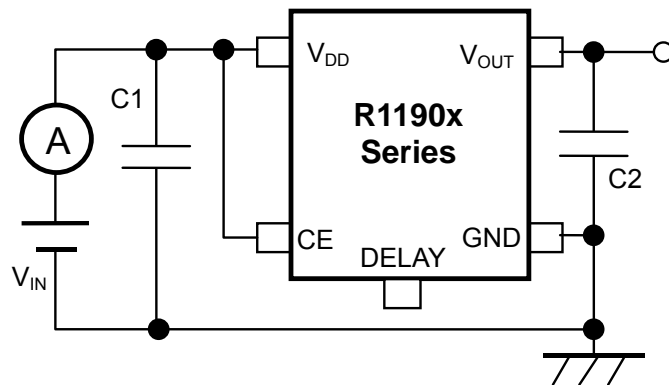

Fig.2 Test Circuit for Supply Current

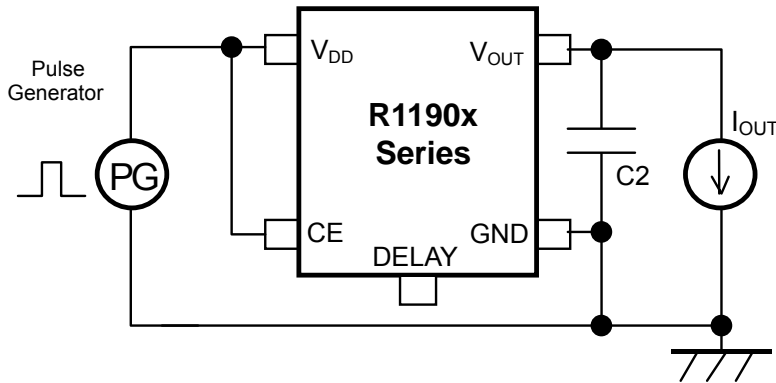

Fig.3 Test Circuit for Ripple Rejection

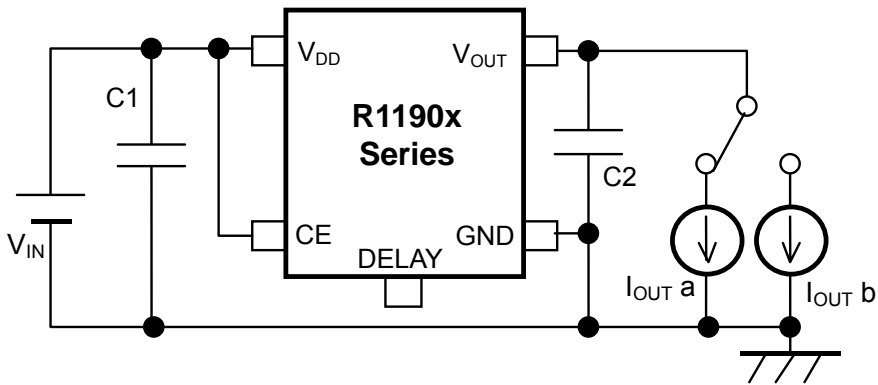

Fig.4 Test Circuit for Load Transient Response

TECHNICAL NOTES

When using these ICs, consider the following points:

Phase Compensation

In these ICs, phase compensation is made for securing stable operation even if the load current is varied. For this purpose, use a capacitor C_{OUT} with good frequency characteristics and ESR (Equivalent Series Resistance). (Note: If additional ceramic capacitors are connected with parallel to the output pin with an output capacitor for phase compensation, the operation might be unstable. Because of this, test these ICs with as same external components as ones to be used on the PCB.)

PCB Layout

Make V_{DD} and GND lines sufficient. If their impedance is high, noise pickup or unstable operation may result. Connect a capacitor with a capacitance value as much as $4.7\mu\text{F}$ or more between V_{DD} and GND pin, and as close as possible to the pins.

Set external components, especially the output capacitor, as close as possible to the ICs, and make wiring as short as possible. (Refer to the TYPICAL APPLICATION diagram below)

Thermal Shutdown Function

There is the built-in thermal-shutdown function in R1190 series. It discontinues operation of the IC when the junction temperature becomes over 150°C (Typ.) and IC re-operates when the junction temperature under 130°C . If the temperature increasing keeps the IC repeats ON and OFF operating. The output becomes the pulse condition.

Chip Enable (CE) Circuit

For the output voltage stability, please do not use the intermediate electric potential (the voltage value between V_{CEH} and V_{CEL}) that causes the supply current increasing and the unstable of output voltage.

Inrush-Current Limit Function

R1190 Series has the function to limit the inrush-current, it limited approximately 0.4A when the voltage regulator is turn ON. It is also possible to set time of the rush-current limitation by connecting capacitor with DELAY pin. The rush-current time (t_D) and the value of capacitor (C_D [F]) is calculatable by the following formula;

$$t_D = (0.000198 + (3.79e+7 \times C_D)) \times V_{IN}$$

The inrush-current is limited even if the capacitor is not connected with the DELAY pin. In this case, the time is calculated as $C_D=0$ by the formula above.

Though, if the value of time is insufficient for controlling the inrush-current, please connect the capacitor with DELAY pin. The DELAY pin is used as OPEN when the capacitor is not used. Please use the DELAY pin as OPEN when the capacitor is not used.

Auto-Discharge Function

R1190xxxxD series has the auto-discharge function. When "L" signal is put into the Chip-enable pin (CE), the switch between V_{OUT} and GND is turned ON and the charge at capacitor is discharged rapidly by the auto-discharge function.

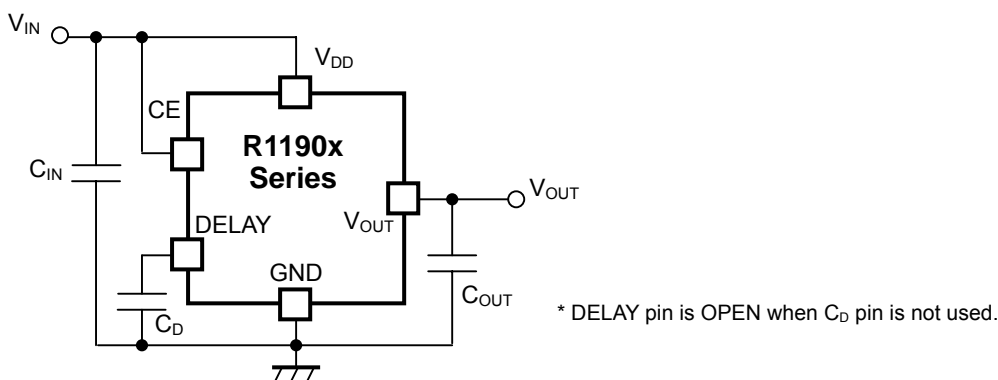

TYPICAL APPLICATION

(External Components)

C_{IN} : $4.7\mu\text{F}$

C_{OUT} : $4.7\mu\text{F}$

POWER DISSIPATION (TO-252-5-P2)

This specification is at mounted on board. Power Dissipation (P_D) depends on conditions of mounting on board. This specification is based on the measurement at the condition below:

Measurement conditions

	Standard land pattern
Environment	Mounting on board (Wind velocity 0m/s)
Board Material	Glass cloth epoxy plastic (Double layers)
Board Dimensions	50mm * 50mm * t1.6mm
Copper Ratio	Top side: Approx. 50%, Back side: Approx. 50%
Through - hole	ϕ 0.5mm * 24pcs

Measurement Results

($T_a=25^\circ\text{C}$, $T_{j\text{max}}=125^\circ\text{C}$)

	Standard land pattern
Power Dissipation	1900mW
Thermal Resistance	$\theta_{ja} = (125-25^\circ\text{C})/1.9\text{W} = 53^\circ\text{C/W}$

TO-252-5 Power Dissipation

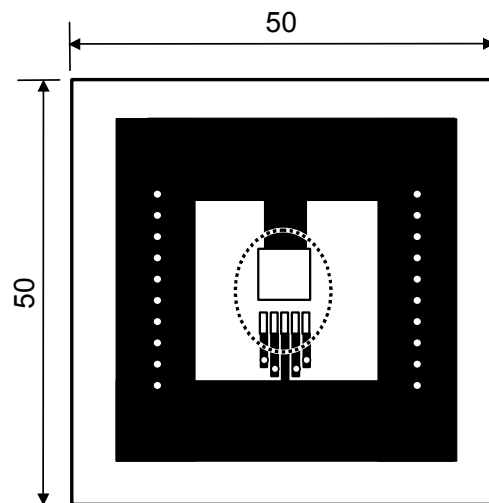
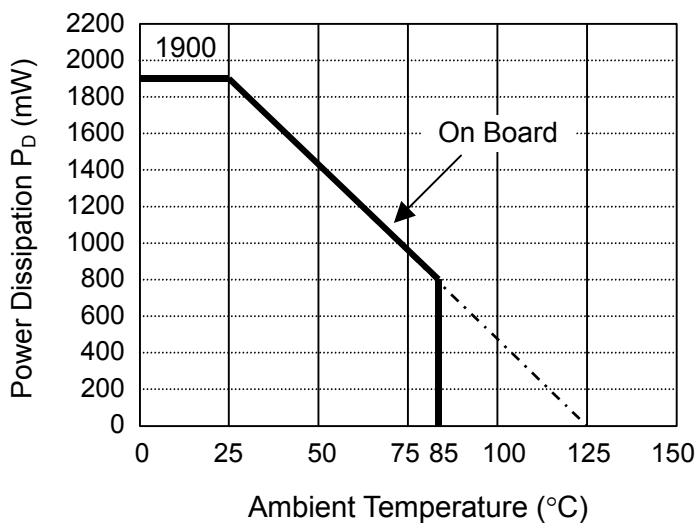

Measurent Board Pattern

○ IC Mount Area Unit : mm

POWER DISSIPATION (SOT-89-5)

This specification is at mounted on board. Power Dissipation (P_D) depends on conditions of mounting on board. This specification is based on the measurement at the condition below:

Measurement Conditions

	High Wattage Land Pattern	Standard Land Pattern
Environment	Mounting on Board (Wind velocity=0m/s)	Mounting on Board (Wind velocity=0m/s)
Board Material	Glass cloth epoxy plastic (Double sided)	Glass cloth epoxy plastic (Double sided)
Board Dimensions	30mm * 30mm * 1.6mm	50mm * 50mm * 1.6mm
Copper Ratio	Top side : Approx. 20% , Back side : Approx. 100%	Top side : Approx. 10% , Back side : Approx. 100%
Through-hole	$\phi 0.85\text{mm} * 10\text{pcs}$	-

Measurement Result

($T_a=25^\circ\text{C}$, $T_{j\text{max}}=125^\circ\text{C}$)

	High Wattage Land Pattern	Standard Land Pattern	Free Air
Power Dissipation	1300mW	900mW	500mW
Thermal Resistance	77°C/W	111°C/W	200°C/W

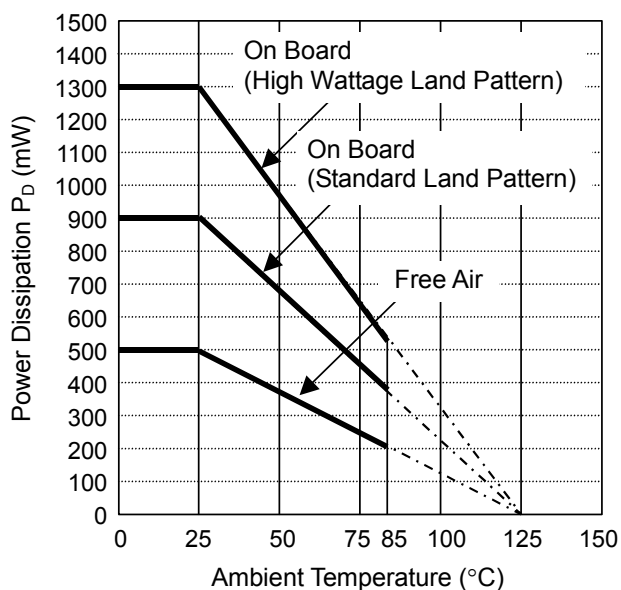

Power Dissipation

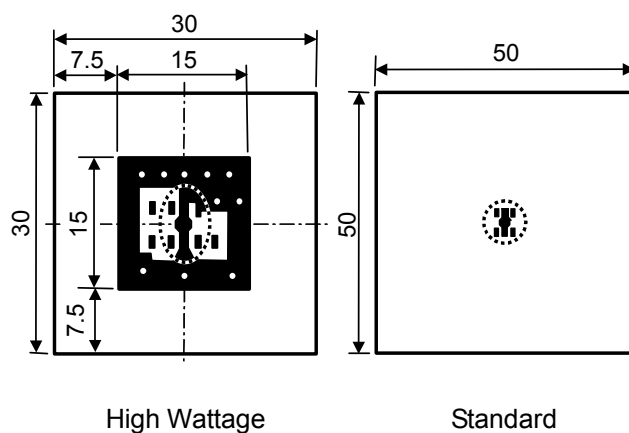

Measurent Board Pattern

 IC Mount Area Unit : mm

POWER DISSIPATION (HSOP-6J)

This specification is at mounted on board. Power Dissipation (P_D) depends on conditions of mounting on board. This specification is based on the measurement at the condition below:

Measurement Conditions

	High Wattage Land Pattern	Standard Land Pattern
Environment	Mounting on Board (Wind velocity=0m/s)	Mounting on Board (Wind velocity=0m/s)
Board Material	Glass cloth epoxy plastic (Double sided)	Glass cloth epoxy plastic (Double sided)
Board Dimensions	50mm * 50mm * 1.6mm	50mm * 50mm * 1.6mm
Copper Ratio	90%	50%
Through-hole	$\phi 0.5\text{mm} * 24\text{pcs}$	$\phi 0.5\text{mm} * 24\text{pcs}$

Measurement Result

($T_a=25^\circ\text{C}, T_{j\text{max}}=125^\circ\text{C}$)

	High Wattage Land Pattern	Standard Land Pattern	Free Air
Power Dissipation	2000mW	1700mW	540mW
Thermal Resistance	50°C/W	59°C/W	185°C/W

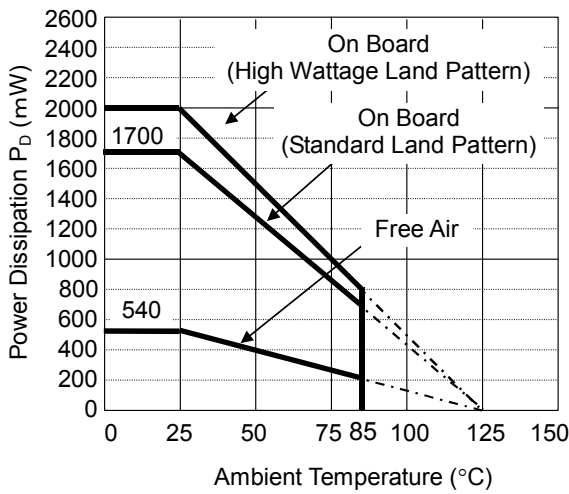

Power Dissipation

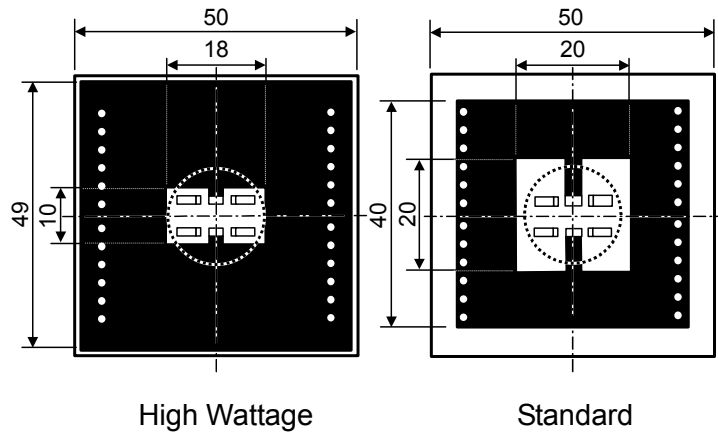

Measurement Board Pattern

IC Mount Area Unit : mm

TYPICAL CHARACTERISTICS

1-1 Output Voltage vs. Output Current $C_{IN}=4.7\mu F, C_{OUT}=4.7\mu F$

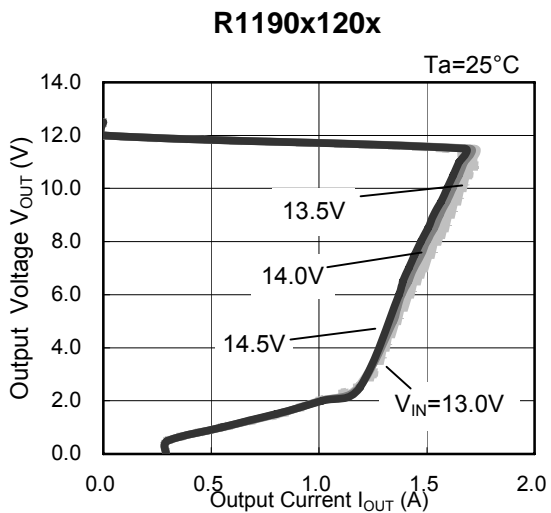
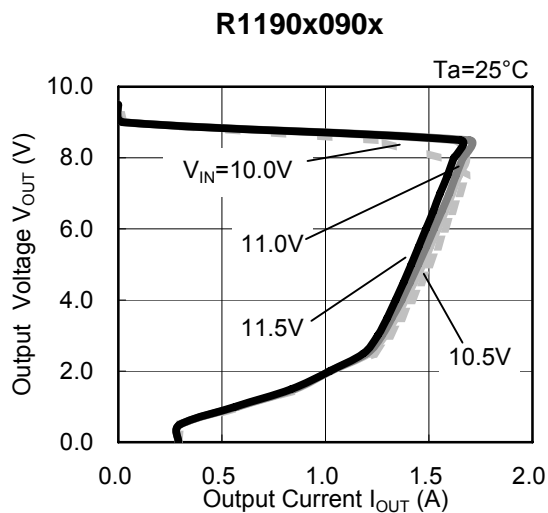
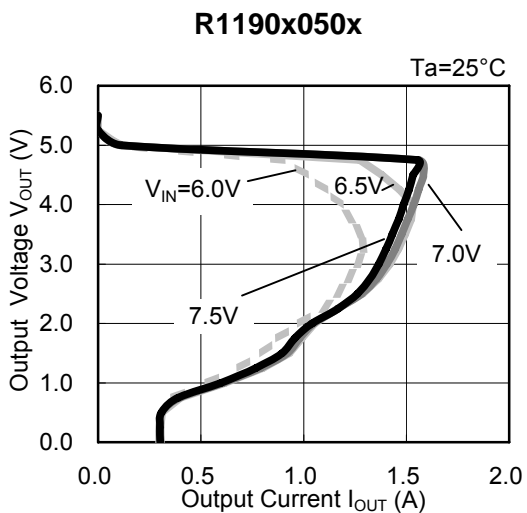
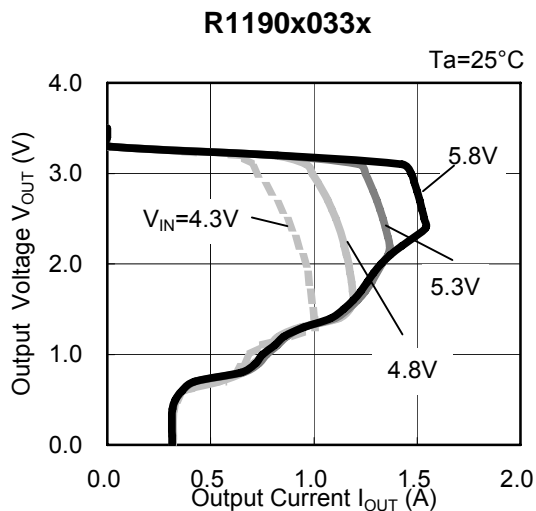
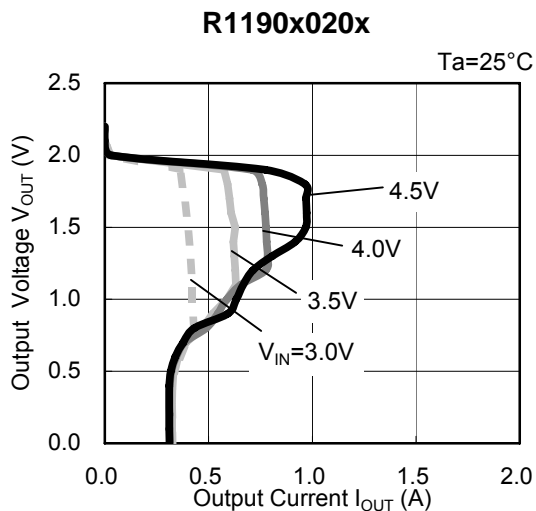

Symbol	V _{DD}
.....	V _{SET} +1.0V
-----	V _{SET} +1.5V
-----	V _{SET} +2.0V
-----	V _{SET} +2.5V

1-2. Output Voltage vs. Input Voltage

$C_{IN}=4.7\mu F, C_{OUT}=4.7\mu F$

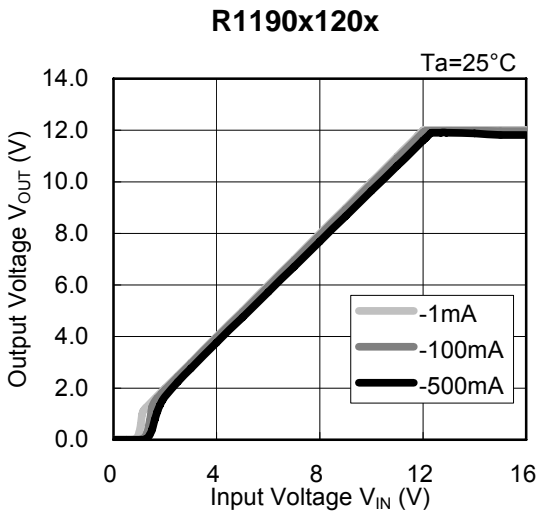
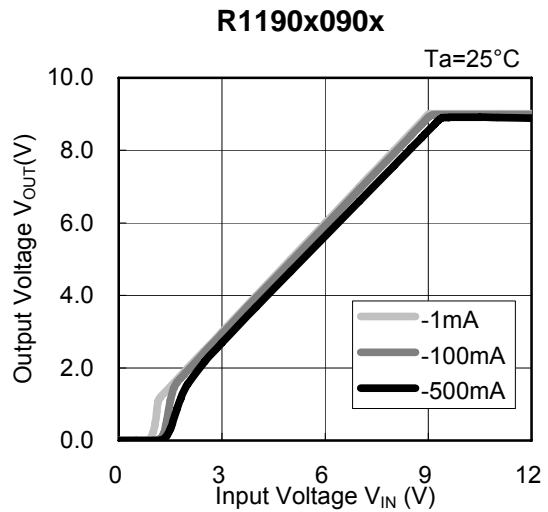
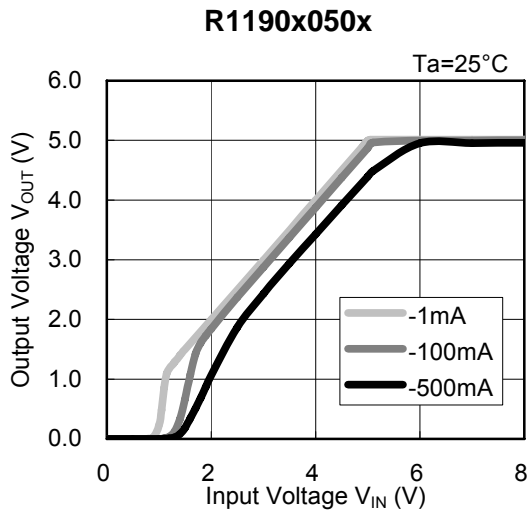
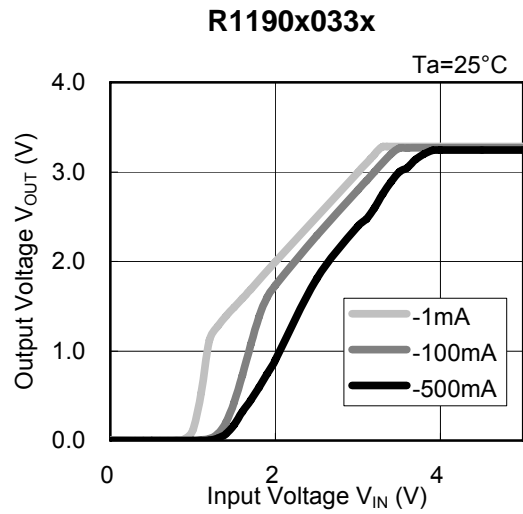
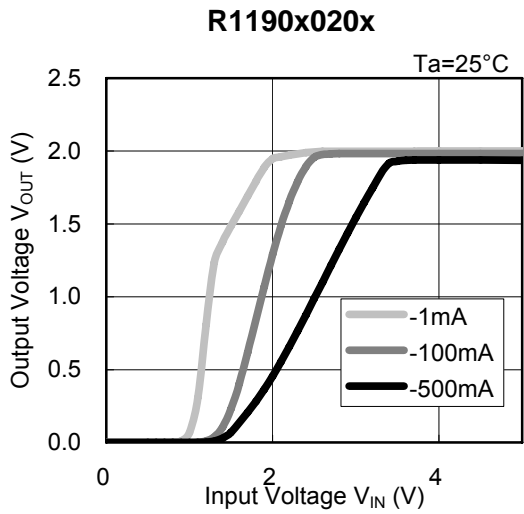

Symbol	
	$I_{OUT}=1mA$
	$I_{OUT}=100mA$
	$I_{OUT}=500mA$

1-3. Supply Current vs. Input Voltage

$C_{IN}=4.7\mu F, C_{OUT}=4.7\mu F$

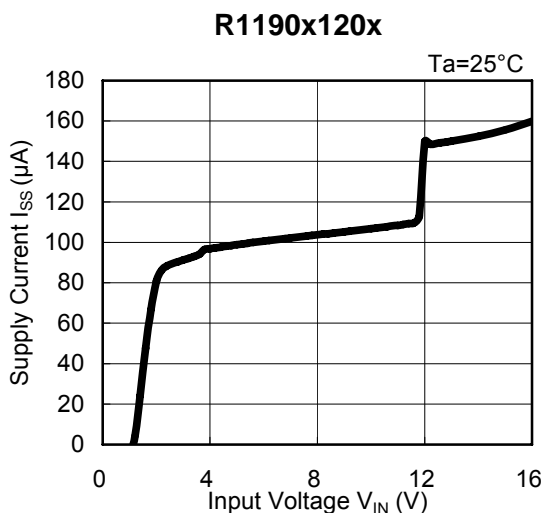
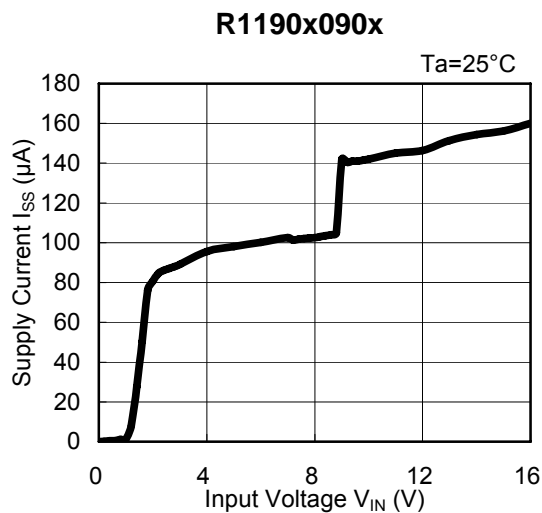
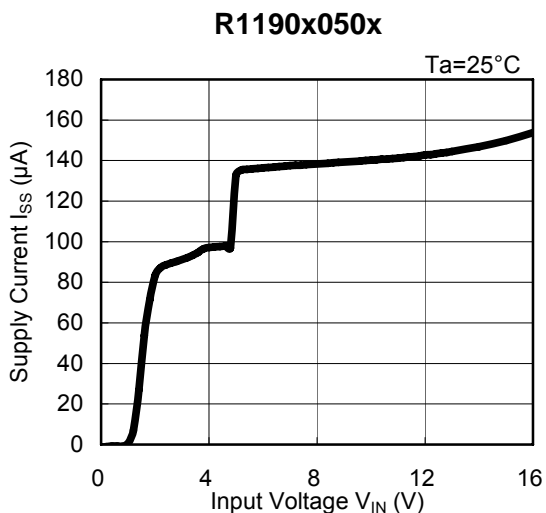
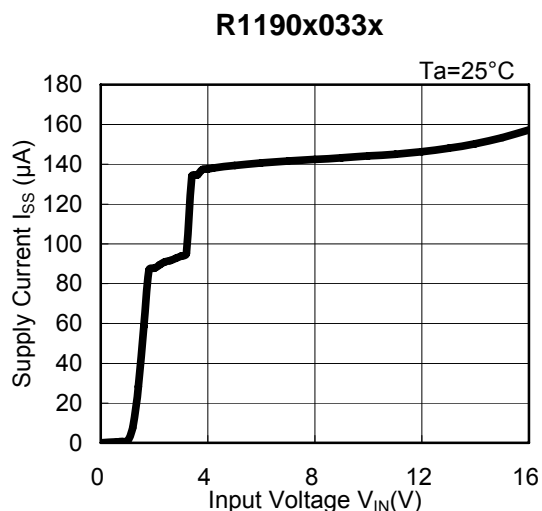
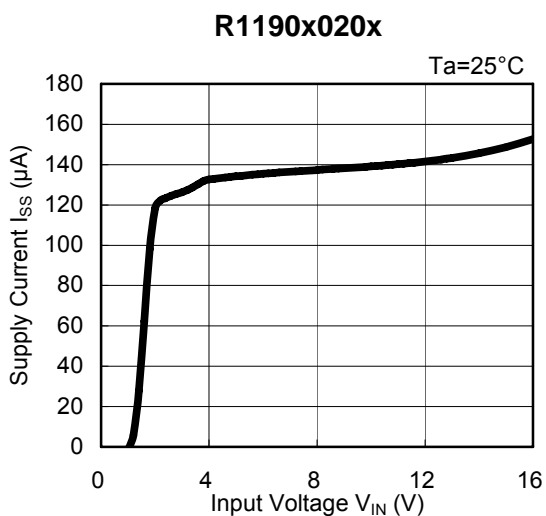

1-4. Output voltage vs. Temperature

$C_{IN}=4.7\mu F, C_{OUT}=4.7\mu F$

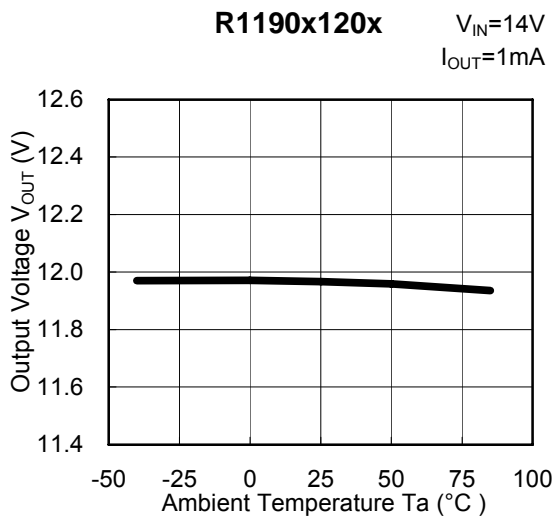
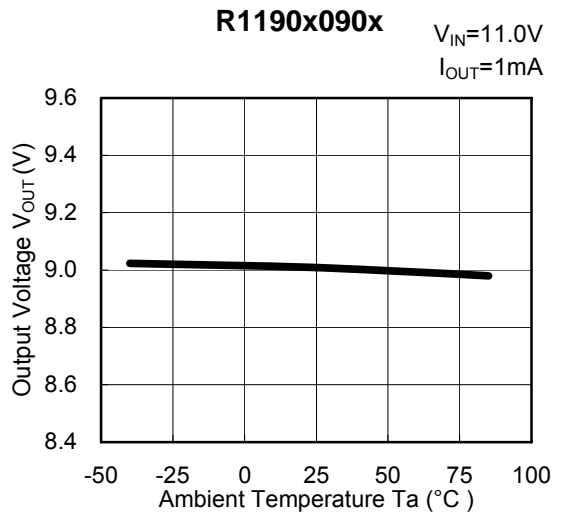
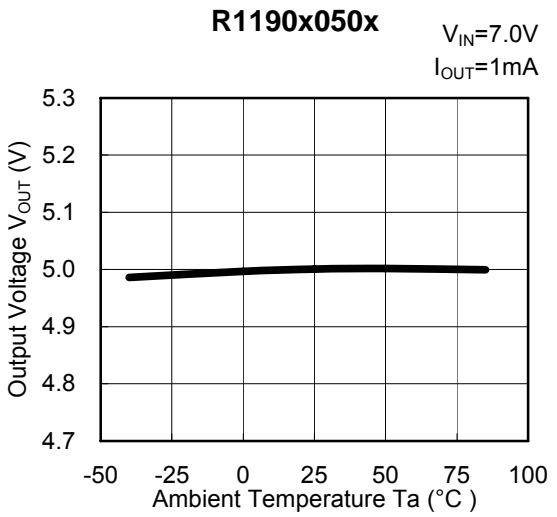
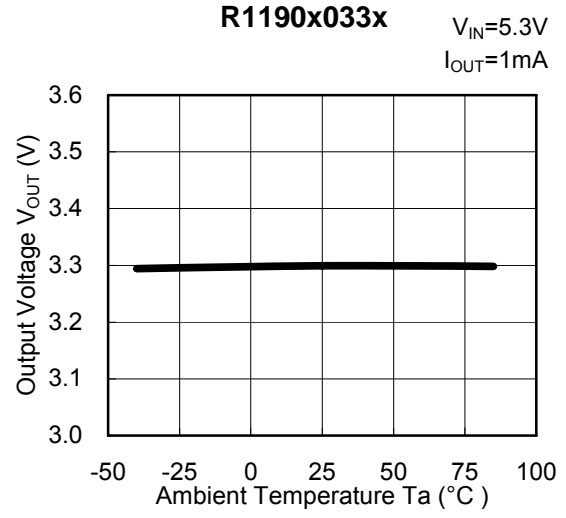
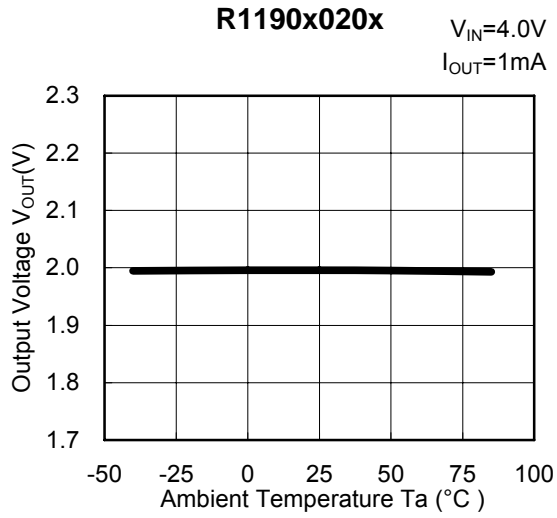

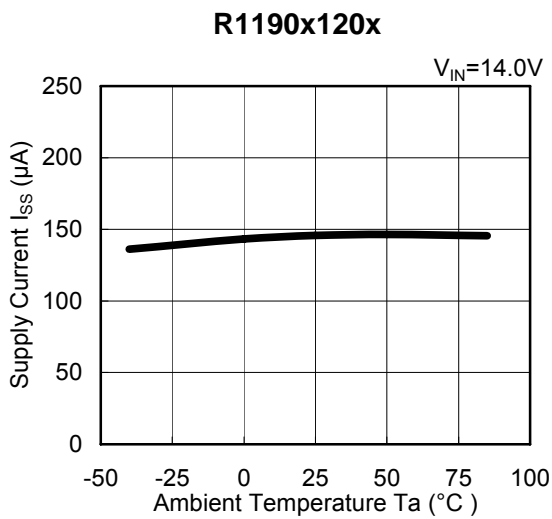
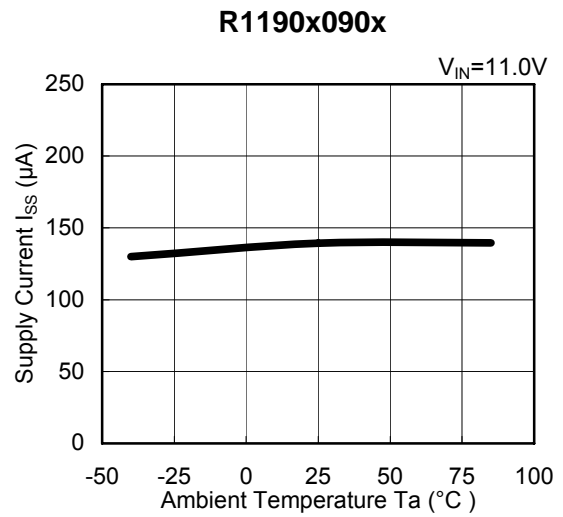
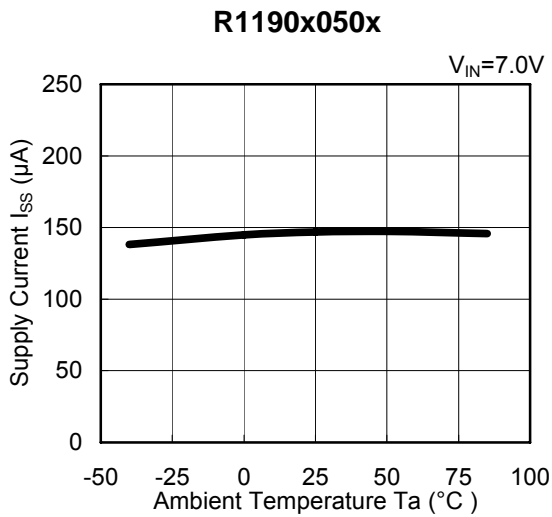
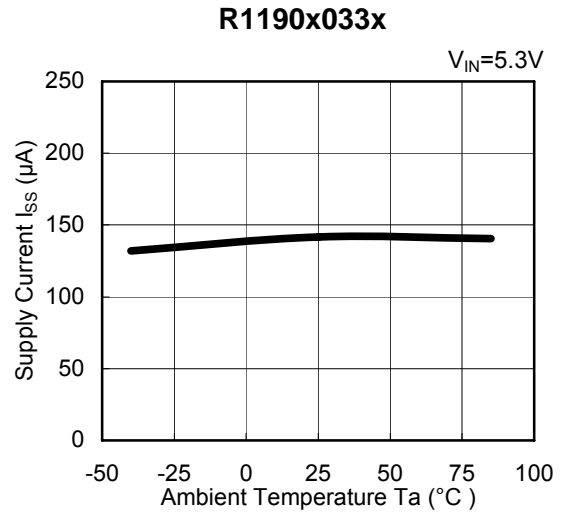
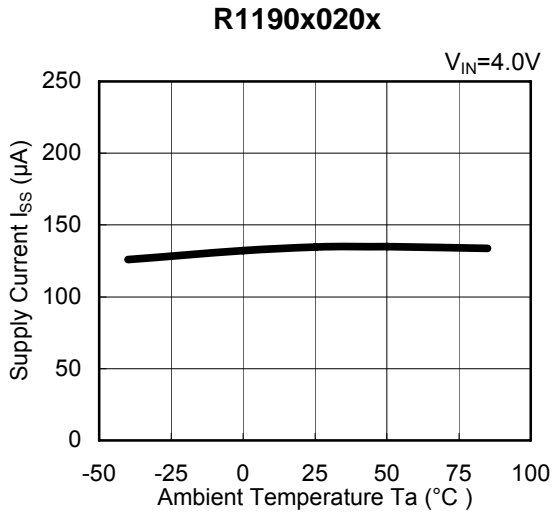

1-6.Dropout Voltage vs. Output Current $C_{IN}=4.7\mu F, C_{OUT}=4.7\mu F$

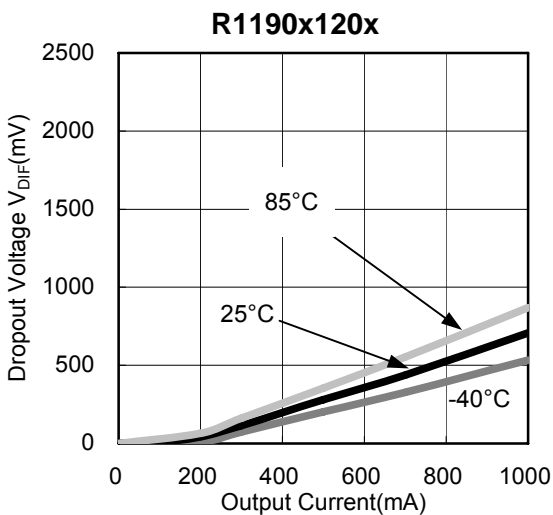
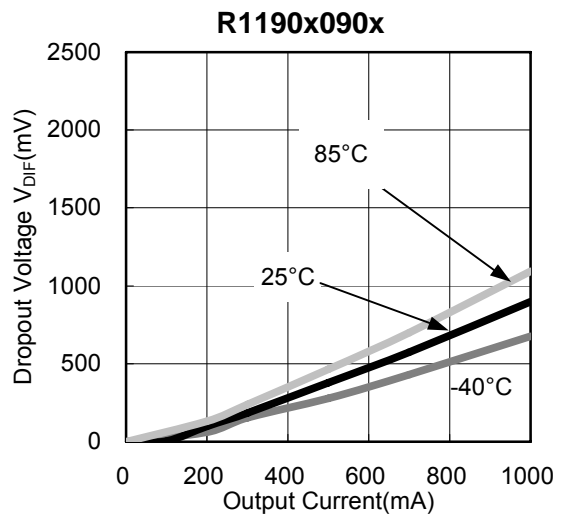
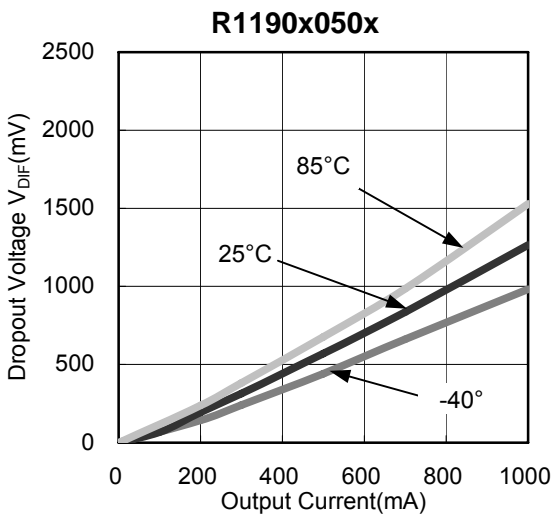
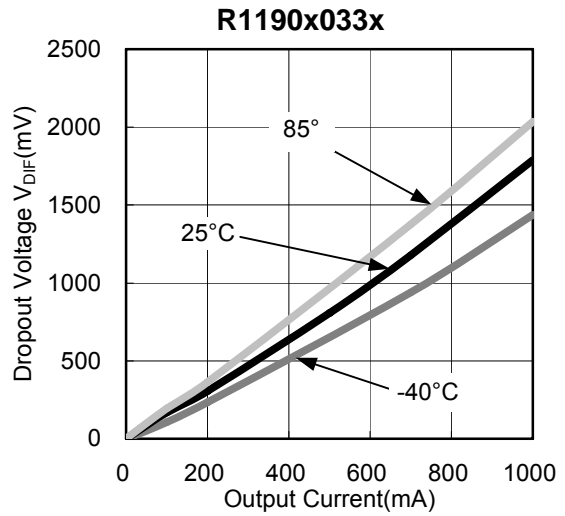
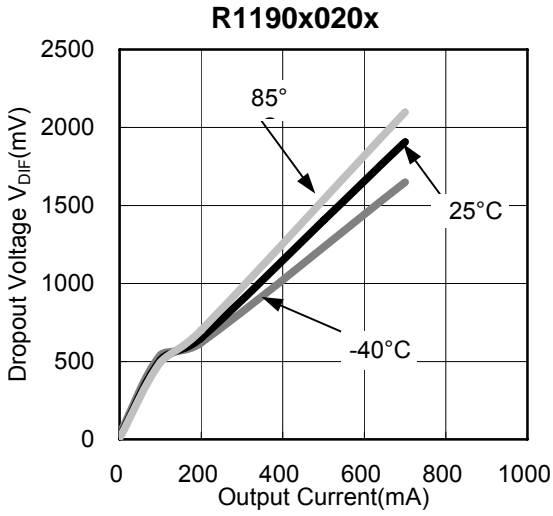

Symbol	VDD
	-40°C
	25°C
	85°C

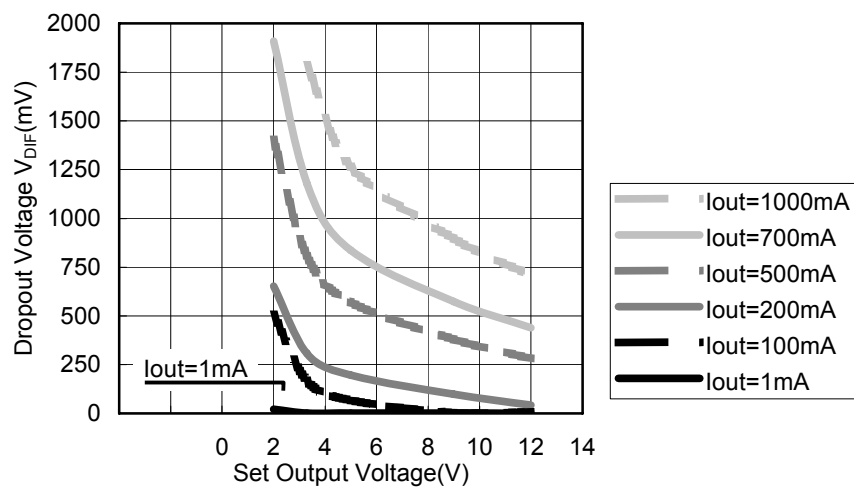
1-7. Dropout Voltage vs. Set Output Voltage $C_{IN}=4.7\mu F$, $C_{OUT}=4.7\mu F$ 

1-8.Ripple Rejection vs. Input Voltage

C_{IN} =Open, C_{OUT} =4.7 μ F
 Input Ripple=0.2Vp-p
 I_{OUT} =100mA

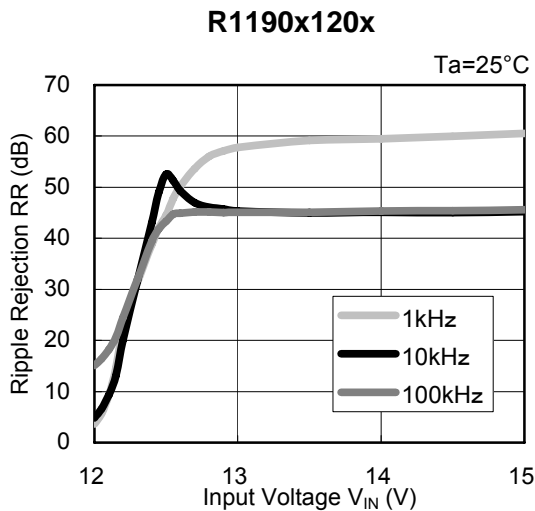
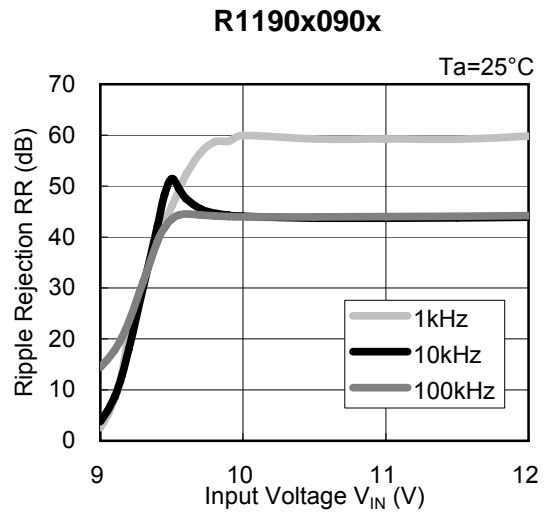
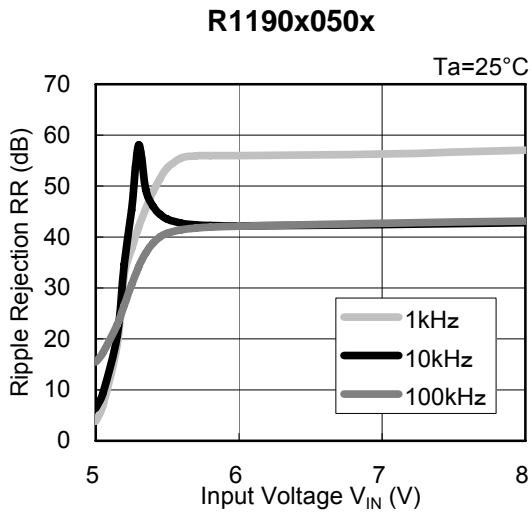
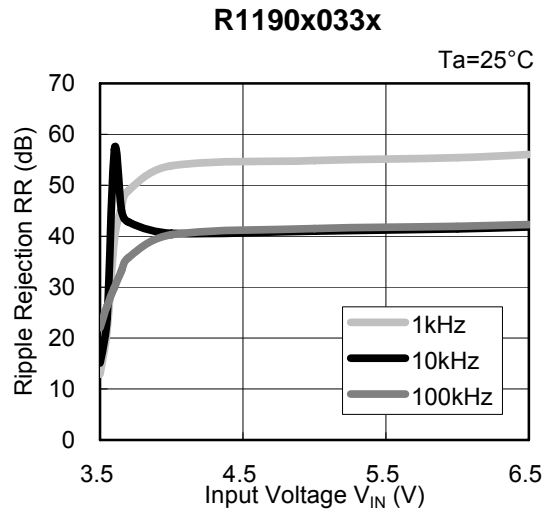
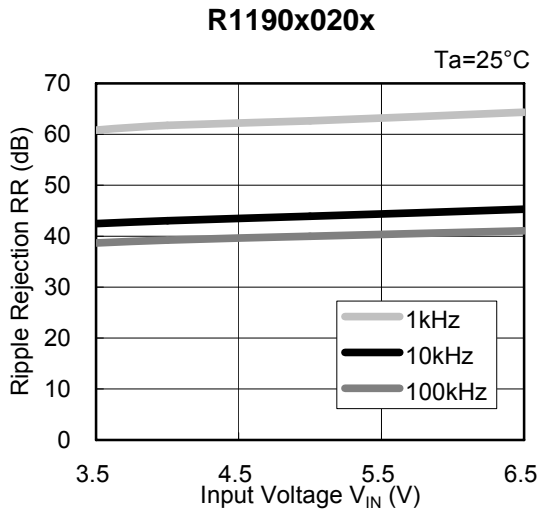

Symbol	
	1kHz
	10kHz
	100kHz

1-9.Ripple Rejection vs. Frequency

C_{IN} =Open, C_{OUT} =4.7 μ F
 Input Ripple=0.2Vp-p
 T_a =25°C

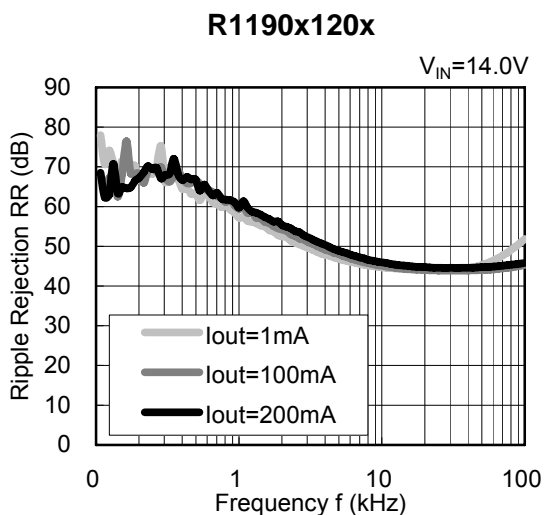
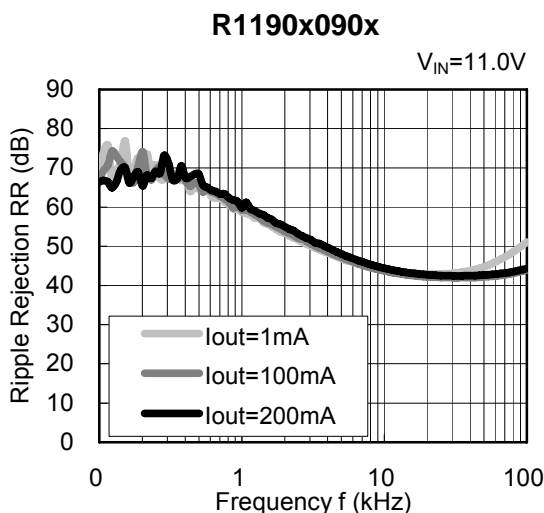
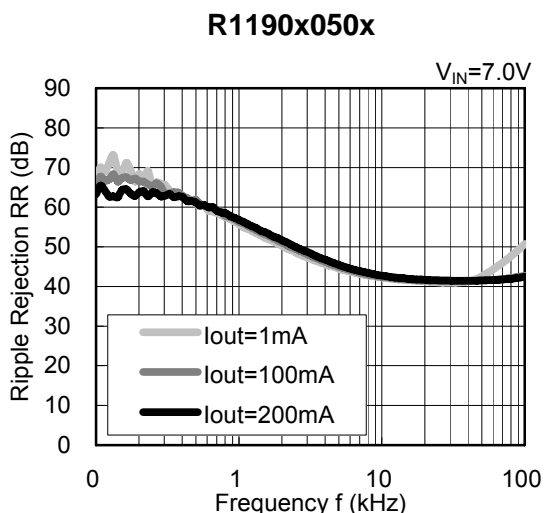
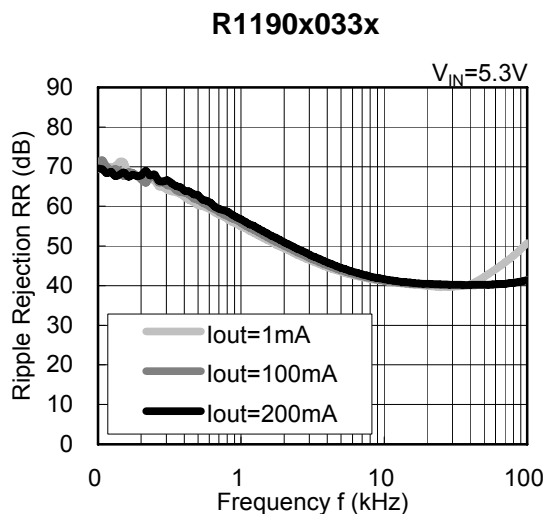
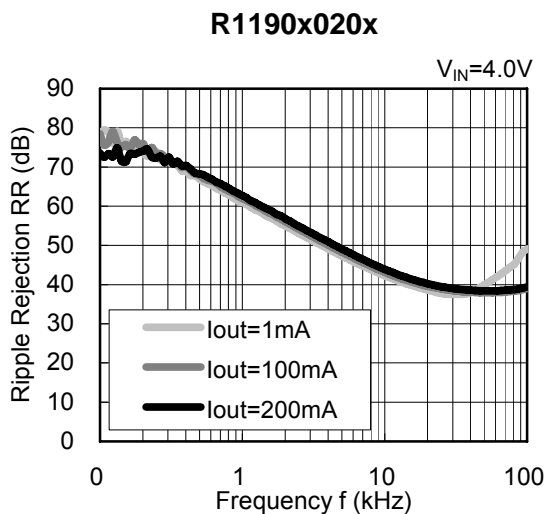

Symbol	
	I_{OUT} =1mA
	I_{OUT} =100mA
	I_{OUT} =200mA

1-10. Input Transient Response

$V_{IN} = V_{SET} + 2 \leftrightarrow V_{SET} + 3$
 $C_{IN} = \text{Open}, C_{OUT} = 4.7\mu\text{F}$
 $PER = 400\mu\text{s}, WID = 200\mu\text{s}, Tr = Tf = 0.5\mu\text{s}$

R1190x020x

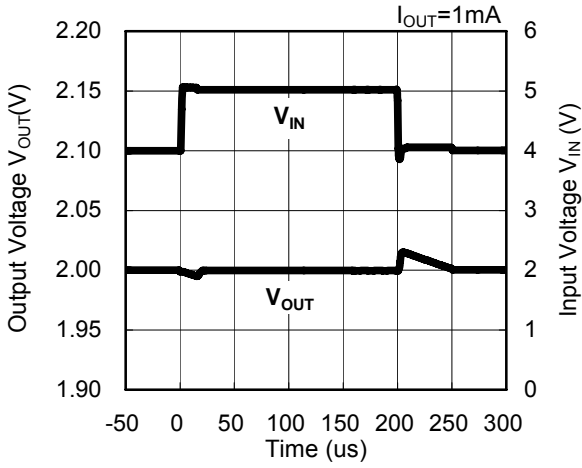

R1190x033x

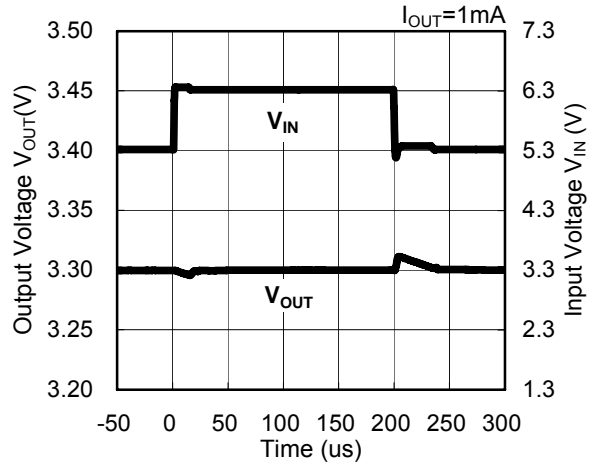

R1190x050x

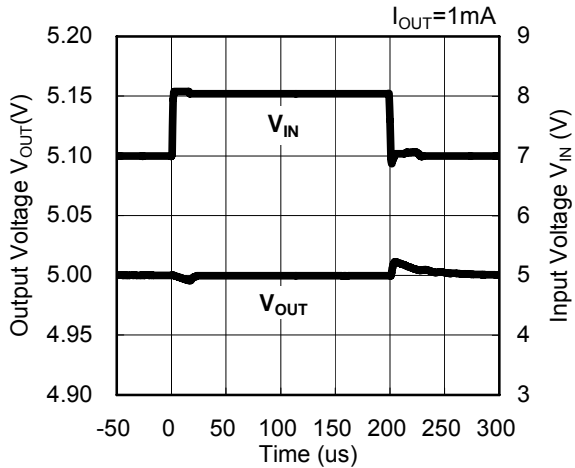

R1190x090x

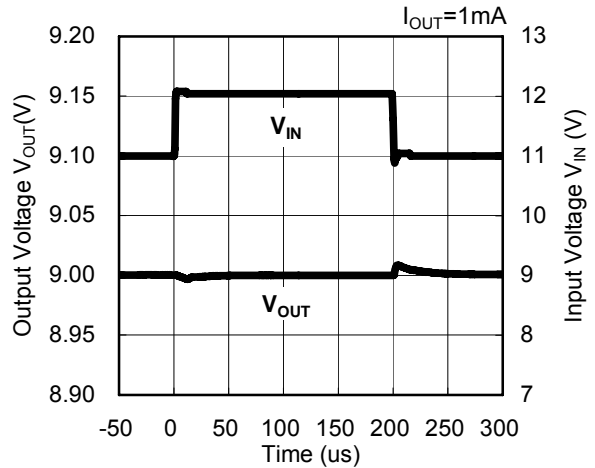

R1190x120x

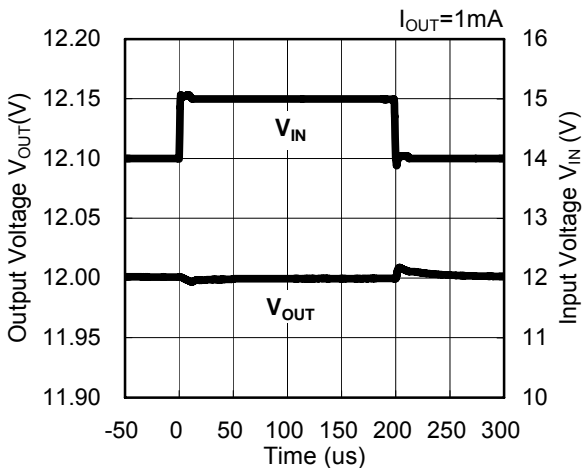

1-11. Load Transient Response

$2.0 \leq V_{SET} < 3.3$: $V_{IN} = CE = V_{SET} + 2.3V$, $I_{OUT} = 1mA \rightarrow 700mA$, $C_{IN} = 4.7\mu F$, $C_{OUT} = 4.7\mu F$

$3.3 \leq V_{SET} \leq 12.0$: $V_{IN} = CE = V_{SET} + 2.3V$, $I_{OUT} = 1mA \rightarrow 1000mA$, $C_{IN} = 4.7\mu F$, $C_{OUT} = 4.7\mu F$

PER=400 μs , WID=200 μs , Tr=Tf=0.5 μs

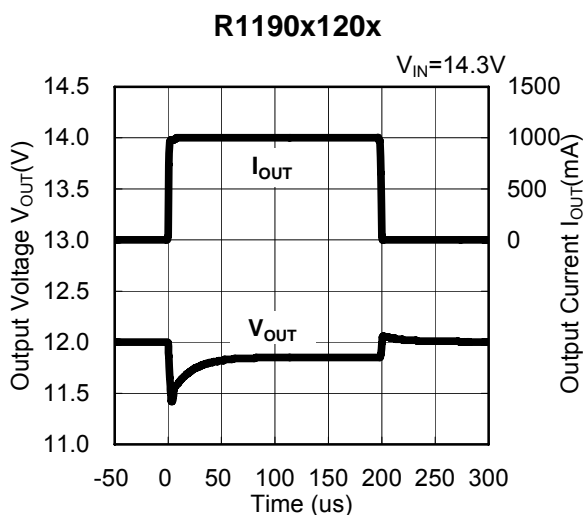
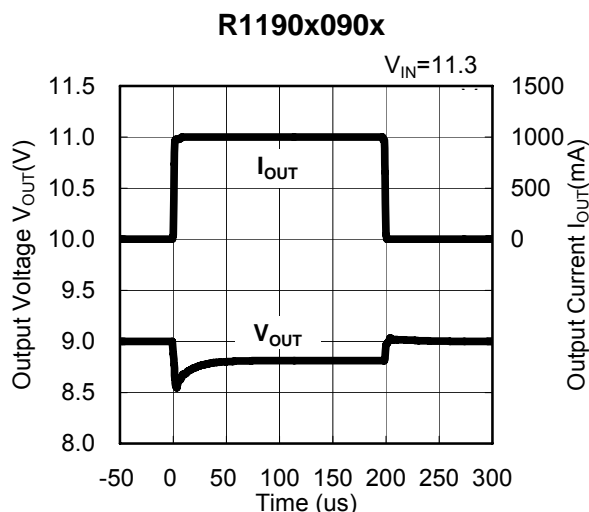
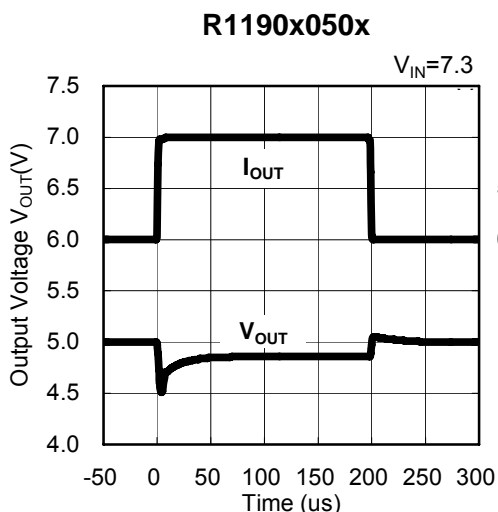
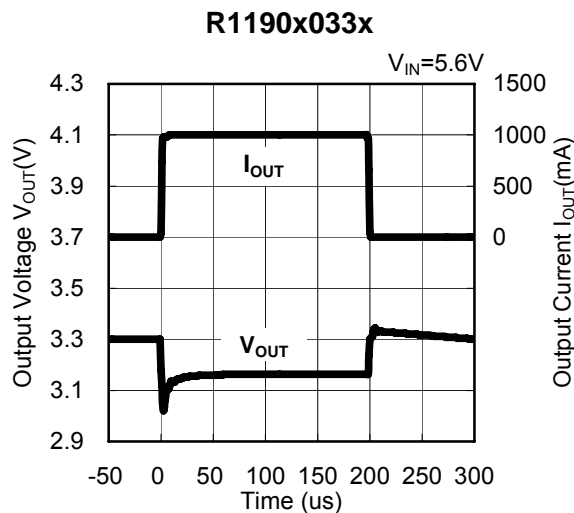
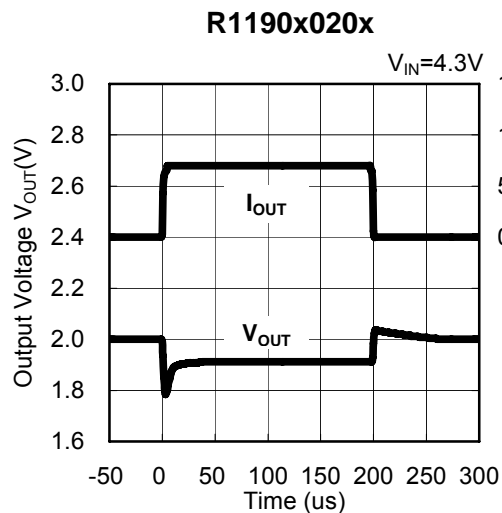

1-12.Turn On Speed with CE Pin

$V_{IN}=V_{SET}+2V$ $I_{OUT}=1mA$
 $C_{IN}=4.7\mu F$, $C_{OUT}=4.7\mu F$
 $PER=1ms$, $WID=500\mu s$, $Tr=Tf=0.5\mu s$

R1190x020x

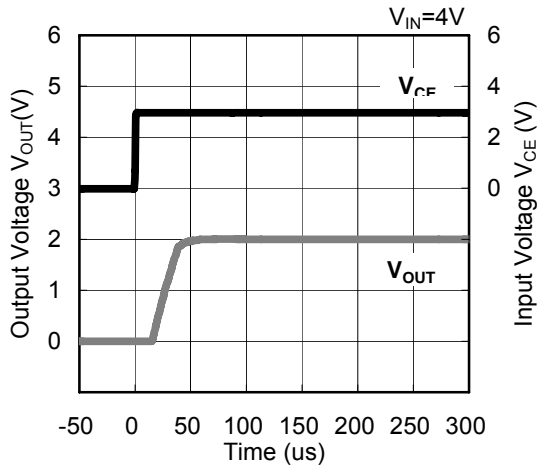

R1190x050x

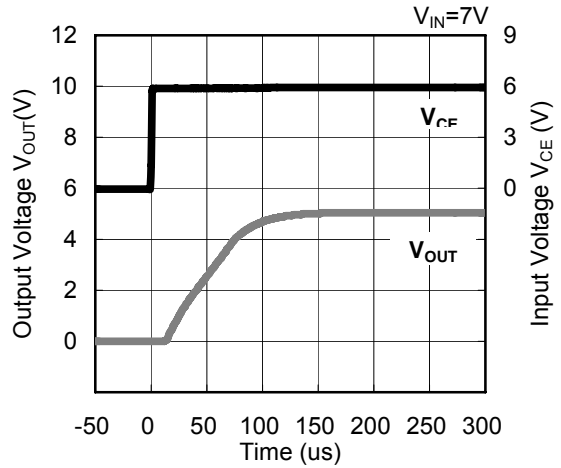

R1190x090x

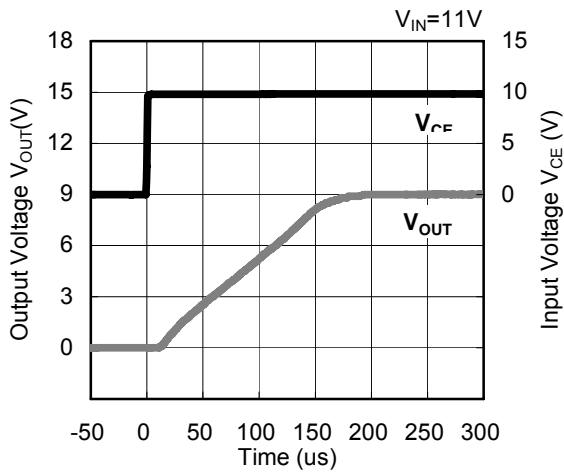

R1190x120x

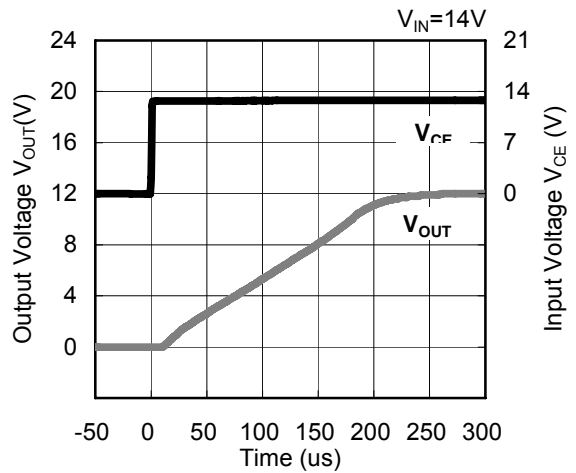

1-13. Turn Off Speed with CE Pin

$V_{IN}=V_{SET}+2V$ $I_{OUT}=1mA$
 $C_{IN}=4.7\mu F$, $C_{OUT}=4.7\mu F$
 $PER=1ms$, $WID=500\mu s$, $Tr=Tf=0.5\mu s$

R1190x020x

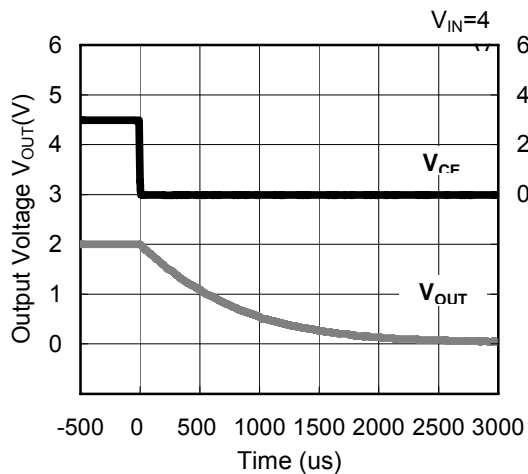

R1190x050x

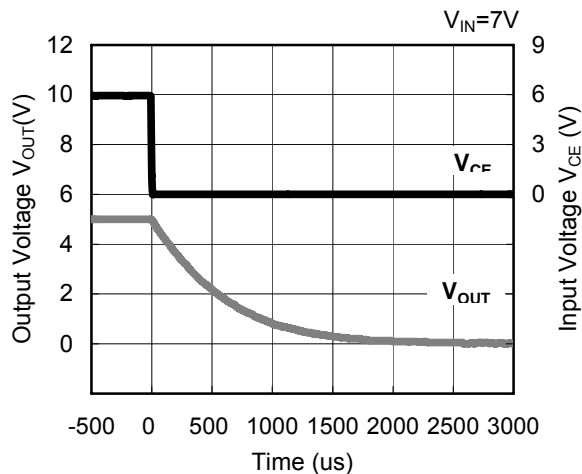

R1190x090x

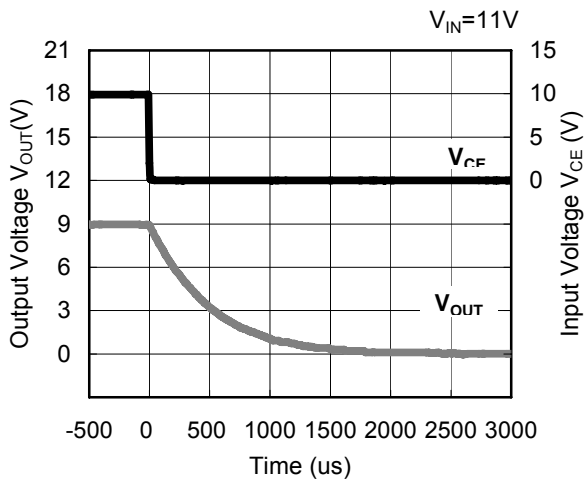

R1190x120x

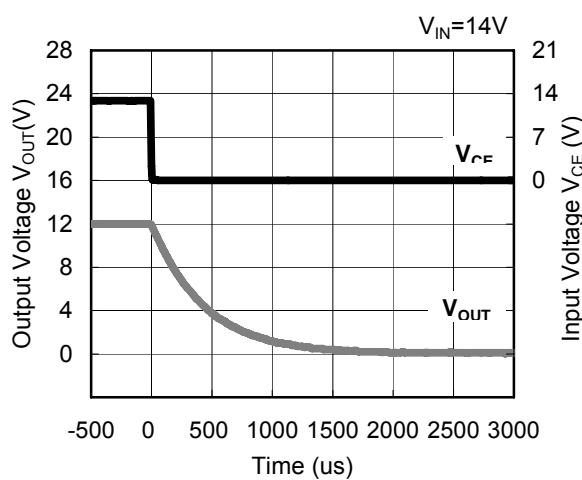

1-14. Inrush Current at Turn On

$V_{IN}=7V$
 $C_{IN}=4.7\mu F, C_{OUT}=4.7\mu F$
 $C_{delay}=Open$
 $PER=1ms, WID=500\mu s, Tr=Tf=0.5\mu s$

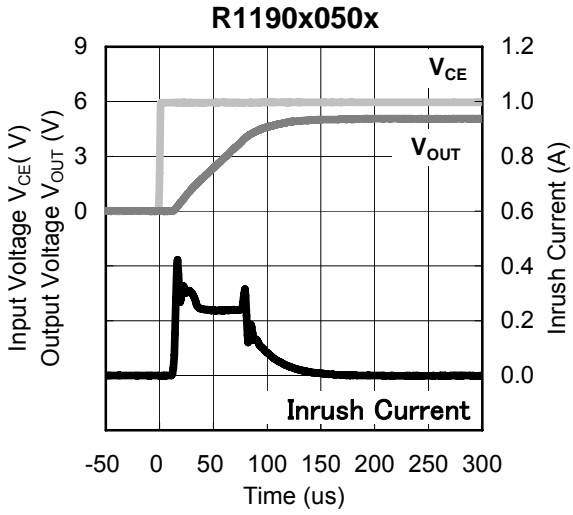

Symbol	
	V_{CE}
	V_{OUT}
	Inrush current

1-15. Inrush Current Limit vs. Cdelay

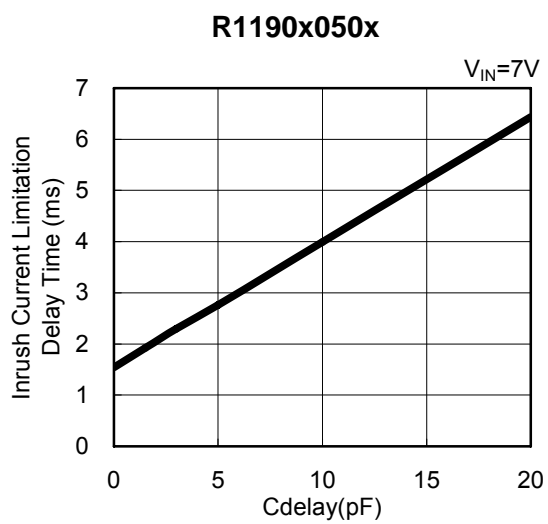
 $C_{IN}=4.7\mu F$, $C_{OUT}=4.7\mu F$ 

1-16. Inrush Current Limiataion Dealy Time vs. Input Voltage

$C_{IN}=4.7\mu F, C_{OUT}=4.7\mu F$

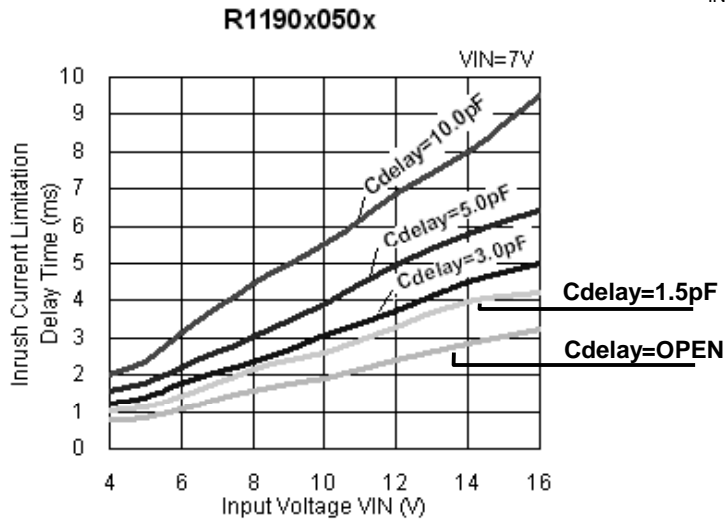

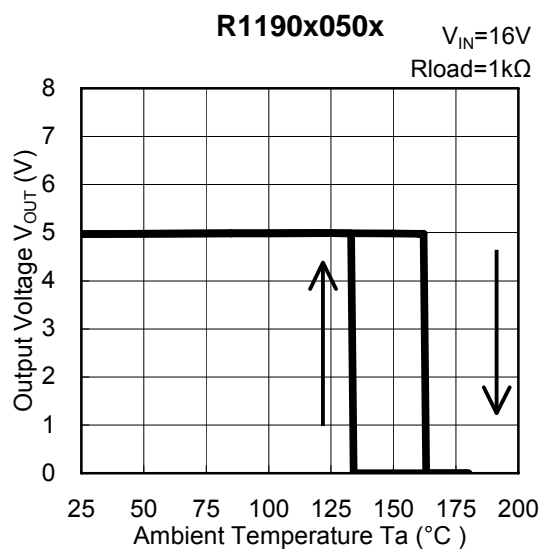
1-17. Thermal Shut Down vs. Temperature $C_{IN}=4.7\mu F$, $C_{OUT}=4.7\mu F$ 

1-18.ESR vs. Output Current

< Measurement Conditions >

- Input Voltage : $V_{SET}+2.3V\sim 16.0V$
- Frequency Band : $10Hz\sim 1MHz$
- Temperature : $-40^{\circ}C\sim 85^{\circ}C$
- Hatched Area : Noise level is under $40\mu V_{rms}(Ave.)$
- Capacitor : $C_{IN}=\text{Ceramic } 4.7\mu F$ (KTD500B475M43A0T00)
 $C_{OUT}=\text{Ceramic } 4.7\mu F$ (KTD500B475M43A0T00)
 $C_{OUT}=\text{Ceramic } 10.0\mu F$ (FK22Y5V1H106Z)

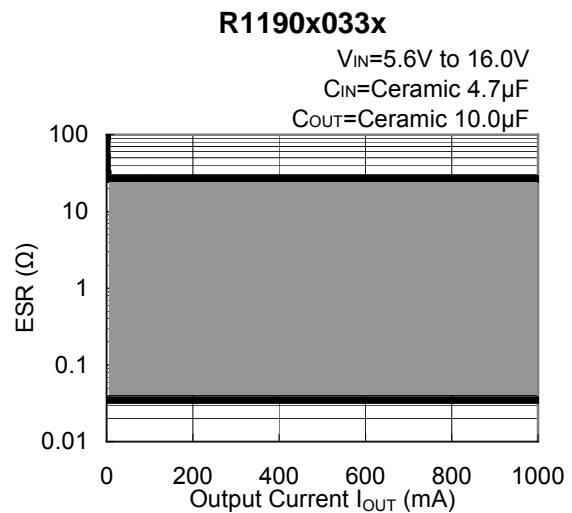
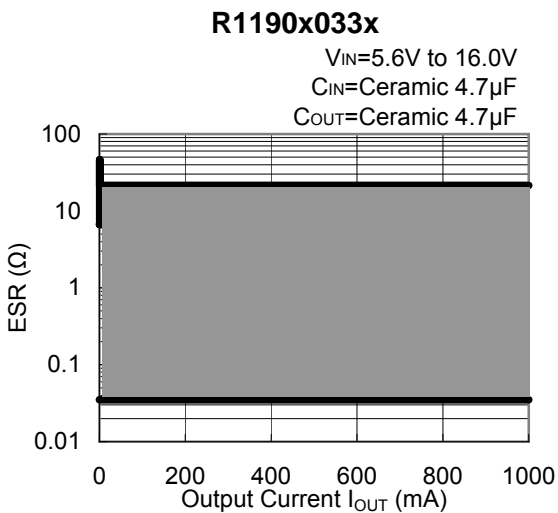
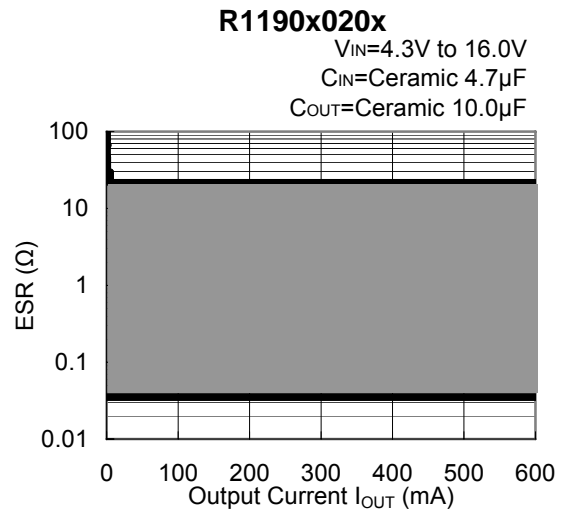
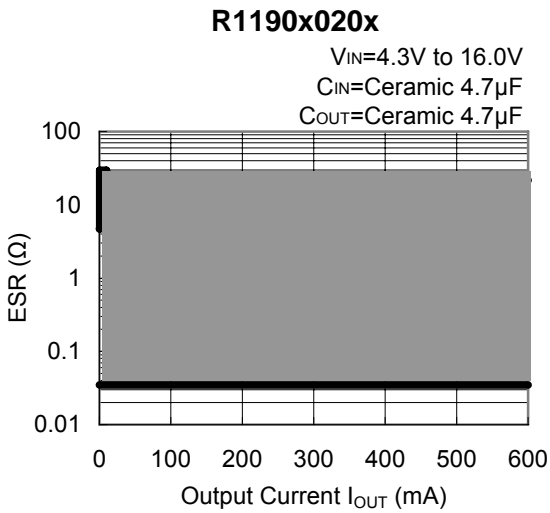

R1190x050x

$V_{IN}=7.3V$ to $16.0V$
 C_{IN} =Ceramic $4.7\mu F$
 C_{OUT} =Ceramic $4.7\mu F$

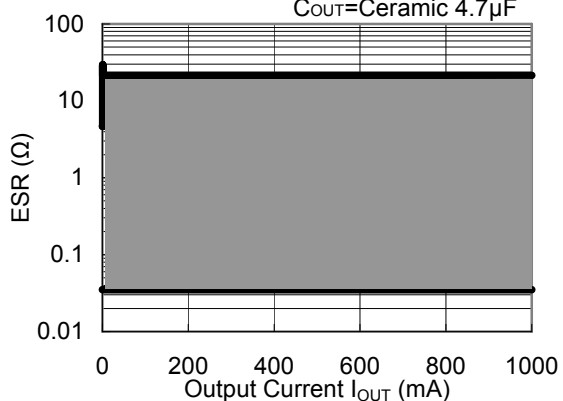

R1190x050x

$V_{IN}=7.3V$ to $16.0V$
 C_{IN} =Ceramic $4.7\mu F$
 C_{OUT} =Ceramic $10.0\mu F$

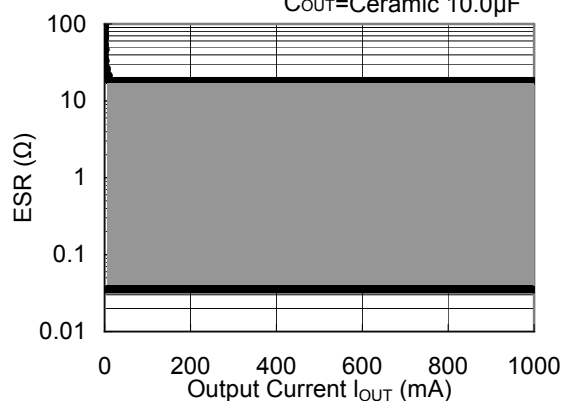

R1190x090x

$V_{IN}=11.3V$ to $16.0V$
 C_{IN} =Ceramic $4.7\mu F$
 C_{OUT} =Ceramic $4.7\mu F$

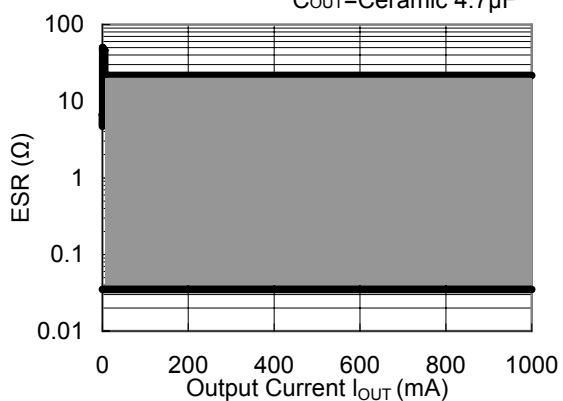

R1190x090x

$V_{IN}=11.3V$ to $16.0V$
 C_{IN} =Ceramic $4.7\mu F$
 C_{OUT} =Ceramic $10.0\mu F$

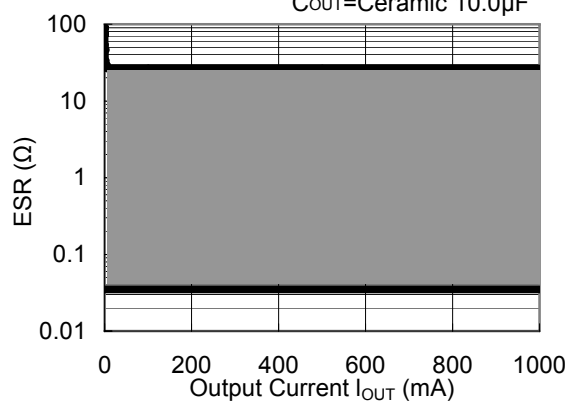

R1190x120x

$V_{IN}=14.3V$ to $16.0V$
 C_{IN} =Ceramic $4.7\mu F$
 C_{OUT} =Ceramic $4.7\mu F$

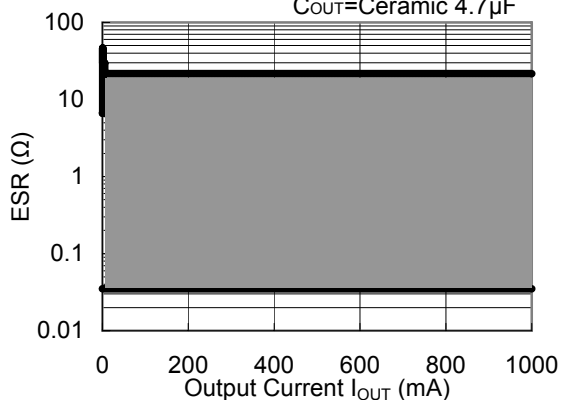

R1190x120x

$V_{IN}=14.3V$ to $16.0V$
 C_{IN} =Ceramic $4.7\mu F$
 C_{OUT} =Ceramic $10.0\mu F$

