

NOTES: UNLESS OTHERWISE SPECIFIED

1. FOR GENERAL SERIES SPECIFICATIONS, SEE SD74-0000.

2. MATERIAL SPECIFICATIONS: BRASS PER ASTM B16.

3. FINISH SPECIFICATIONS:

.000030 MIN. GOLD PER ASTM B488 OVER .000050 MIN. NICKEL PER AMS QQ-N-290.

4. ELECTRICAL SPECIFICATIONS:

CURRENT RATING: 40 AMPS  
CONTACT RESISTANCE: 1.0 MILLIOHM MAX

5. FOR USE WITH 8 AWG WIRE OR EQUIVALENT.

6. REFER TO CAP10-01 FOR CABLE ASSEMBLY PROCEDURE.

REV	DESCRIPTION	BY DATE	APPD
F	ECR 8954	PSM 03/31/06	PSM

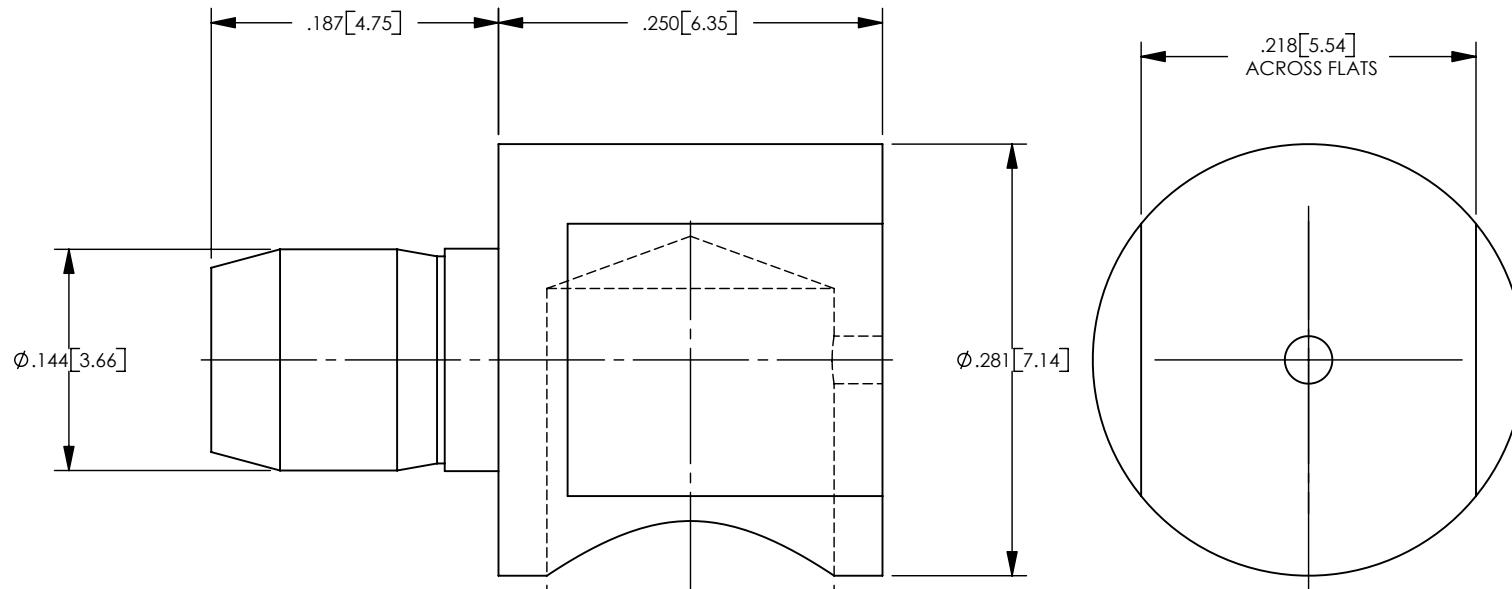

CATALOG P/N: 01131

PER ASME Y14.5M-1994  
UNLESS OTHERWISE SPECIFIED:  
DIMENSIONS ARE IN INCHES [MM]  
TOLERANCES:  
DECIMAL: .XX ± .01 [0.3]  
.XXX ± .005 [0.13]  
.XXXX ± .XXXX  
ANGLES: ± 2° SCALE: 8:1

**NORTHROP GRUMMAN**  
**Winchester Electronics** 62 Barnes Industrial Road North  
Wallingford, CT 06492

DRAWN		DATE		APPROVED		DATE	
KJT		03/08/00		XXX		XX/XX/XX	
APPROVED		DATE		APPROVED		DATE	
XXX		XX/XX/XX		XXX		XX/XX/XX	

<b>CUSTOMER DRAWING</b>			<b>RIGHT ANGLE SOLDER MOUNT POWERSNAP</b>	
<b>A</b>	SD01131		SHT 1 OF 1	REV F

RECOMMENDED CABLE TRIM DIMENSIONS  
SCALE: 2:1