

# 1 WATT UNREGULATED DC/DC CONVERTERS

## HB01U

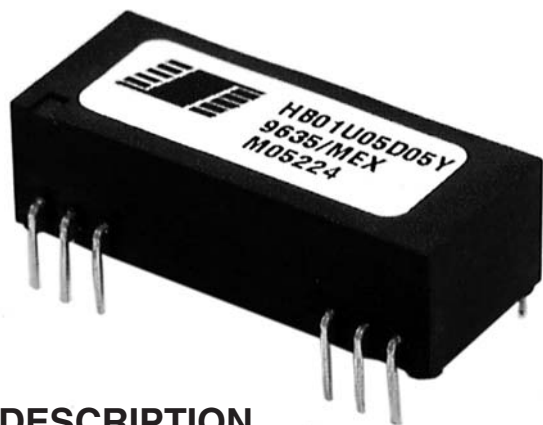

### DESCRIPTION

The HB01U Series offers a wide selection of input and output voltages to choose from. Each model is offered in a 24-pin DIP or SMD package and has an input to output isolation rating of 2500Vrms making it ideal for applications requiring high isolation. The dielectric withstand characteristics of each converter are measured in production to ensure barrier integrity.

The HB01U Series is ideal for applications where the output is susceptible to high voltage transients, such as motor drive and industrial process control applications. The low barrier capacitance gives excellent input to output dV/dt characteristics thus protecting the input control circuitry from peak transients appearing on the output.

The HB01U Series uses a self-oscillating circuit design technology to realize low cost and high performance. The inherent current limiting capability of the high isolation design reduces high current stresses during start-up thus increasing the capacitive load capability while maintaining high reliability.

As with all of our DC/DC converters, surface mount construction combined with extensive qualification testing assures low cost without sacrificing quality and reliability.

### APPLICATIONS

- INDUSTRIAL PROCESS CONTROL
- DC MOTOR DRIVE
- INTRINSIC SAFETY SYSTEMS
- GROUND LOOP ELIMINATION
- MEDICAL EQUIPMENT
- PORTABLE TEST EQUIPMENT
- DATA ACQUISITION

### FEATURES

- HIGH ISOLATION
- 2500Vrms ISOLATION TEST VOLTAGE
- BARRIER 100% PRODUCTION TESTED
- LOW BARRIER CAPACITANCE - 10pF
- LOW LEAKAGE CURRENT - 2 $\mu$ A MAX
- 24-PIN DIP AND SMD
- INTERNAL FILTERING
- NON-CONDUCTIVE CASE
- LOW COST
- LOW PROFILE - .375"

# ELECTRICAL SPECIFICATIONS

Specifications typical at  $T_A = +25^{\circ}\text{C}$ , nominal input voltage, rated output current unless otherwise specified.

MODEL	NOMINAL INPUT VOLTAGE (Vdc)	RATED OUTPUT VOLTAGE (Vdc)	RATED OUTPUT CURRENT (mA)	INPUT CURRENT		EFFICIENCY (%)
				MIN LOAD (mA)	RATED LOAD (mA)	
HB01U05S05	5	5	200	63	290	68
HB01U05S12	5	12	83	63	290	70
HB01U05S15	5	15	67	63	290	73
HB01U12S05	12	5	200	20	120	68
HB01U12S12	12	12	83	20	120	70
HB01U12S15	12	15	67	20	114	73
HB01U15S05	15	5	200	25	98	68
HB01U15S12	15	12	83	25	95	70
HB01U15S15	15	15	67	25	90	73
HB01U24S05	24	5	200	13	61	68
HB01U24S12	24	12	83	13	60	70
HB01U24S15	24	15	67	13	57	73
HB01U05D05	5	$\pm 5$	$\pm 100$	63	290	68
HB01U05D12	5	$\pm 12$	$\pm 42$	63	285	70
HB01U05D15	5	$\pm 15$	$\pm 34$	63	275	73
HB01U12D05	12	$\pm 5$	$\pm 100$	20	123	68
HB01U12D12	12	$\pm 12$	$\pm 42$	20	118	70
HB01U12D15	12	$\pm 15$	$\pm 34$	20	114	73
HB01U15D05	15	$\pm 5$	$\pm 100$	25	98	68
HB01U15D12	15	$\pm 12$	$\pm 42$	25	95	70
HB01U15D15	15	$\pm 15$	$\pm 34$	25	90	73
HB01U24D05	24	$\pm 5$	$\pm 100$	13	61	68
HB01U24D12	24	$\pm 12$	$\pm 42$	13	60	70
HB01U24D15	24	$\pm 15$	$\pm 34$	13	57	73

# COMMON SPECIFICATIONS

Specifications typical at  $T_A = +25^{\circ}\text{C}$ , nominal input voltage, rated output current unless otherwise specified.

PARAMETER	CONDITIONS	MIN	TYP	MAX	UNITS
<b>INPUT</b>					
Voltage Range		4.5 10.8 13.5 20	5 12 15 24 35	5.5 13.2 16.5 30	Vdc Vdc Vdc Vdc mAp-p
Reflected Ripple Current					
<b>ISOLATION</b>					
Rated Voltage		3535			VDC
Test Voltage	60 Hz, 10 Seconds	2500			Vrms
Resistance			10		G $\Omega$
Capacitance			10		pF
Leakage Current	$V_{\text{iso}} = 240\text{V}_{\text{AC}}, 60\text{Hz}$		1	2	$\mu\text{Arms}$
<b>OUTPUT</b>					
Rated Power			1		W
Voltage Setpoint Accuracy			$\pm 3$	$\pm 5$	%
Temperature Coefficient			$\pm 0.02$		%/ $^{\circ}\text{C}$
Ripple & Noise	BW = DC to 10MHz BW = 10Hz to 2MHz		50 25		mVp-p mVrms
Line Regulation	High Line to Low Line		$\pm 1.5$		%/% Vin
Load Regulation	See Performance Curves (Min Load =5%)				
<b>GENERAL</b>					
Switching Frequency			160		kHz
Package Weight			12		g
MTTF per MIL-HDBK-217, Rev. F Ground Benign	Circuit Stress Method $T_A = +25^{\circ}\text{C}$		2,000,000		Hr
Moisture Sensitivity Level (MSL)	Per IPC/JEDEC J-STD 020		2		
<b>TEMPERATURE</b>					
Specification		-25		+70	$^{\circ}\text{C}$
Operation		-40		+85	$^{\circ}\text{C}$
Storage		-40		+110	$^{\circ}\text{C}$

# MECHANICAL Package/Pinout "Y" and "Z"

## DIP PACKAGE

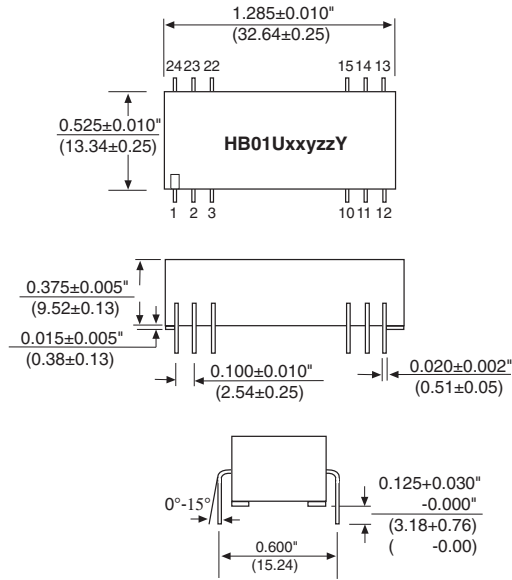

## SMD PACKAGE

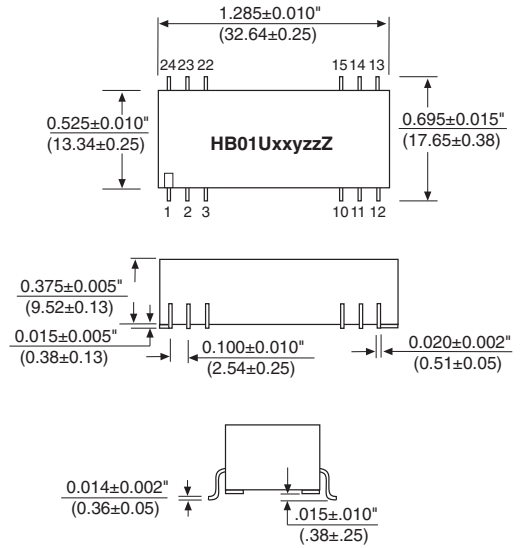

NU = Do Not Use.

NC = No Internal Connection.

Duplicate pin functions are internally connected.

All dimensions are in inches (millimeters).

GRID: 0.100 inches (2.54 millimeters)

Typically Marked with: specific model ordered, date code, job code and Logo.

**MATERIAL:** Units are encapsulated in a low thermal resistance molding compound which has excellent chemical resistance, wide operating temperature range, and good electrical properties under high humidity environments. The encapsulant and outer shell of the unit have UL94V-0 ratings. Lead material is brass with a solder plated surface to allow ease of solderability.

### PIN CONNECTIONS

PIN#	SINGLES	DUALS
1	+VOUT	+VOUT
2	-VOUT	Common
3	NU	-VOUT
10	-VIN	-VIN
11	NC	NC
12	+VIN	+VIN
13	+VIN	+VIN
14	NC	NC
15	-VIN	-VIN
21	NC	NC
22	NU	-VOUT
23	-VOUT	Common
24	+VOUT	+VOUT

## RECOMMENDED LAND PATTERN

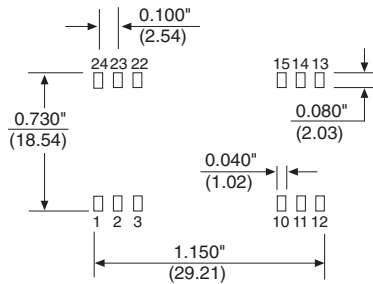

## RECOMMENDED REFLOW PROFILE

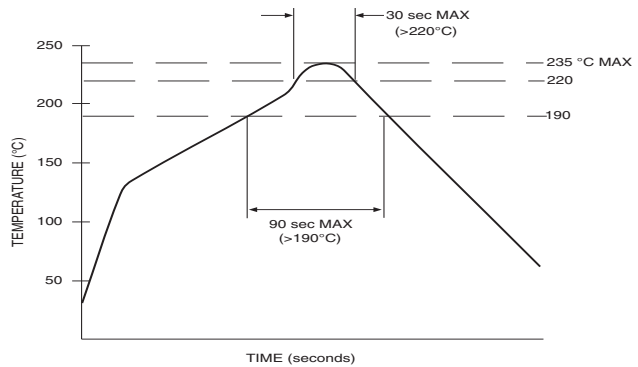

## ABSOLUTE MAXIMUM RATINGS

Internal Power Dissipation.....	0.5 Watt
Short Circuit Duration.....	.5 Min
Lead Temperature (soldering, 10 seconds max).....	+300°C

\*Note: Refer to Reflow Profile for SMD Models.

## ORDERING INFORMATION

Device Family	HB01U	xyzz	Y/Z	/H
HB Indicates DC/DC Converter				
Model Number				
Where:				
xx = Input Voltage				
y = Number or Outputs (Single "S", Dual "D")				
zz = Output Voltage				
Package Option				
Screening Option				

# TYPICAL PERFORMANCE CURVES

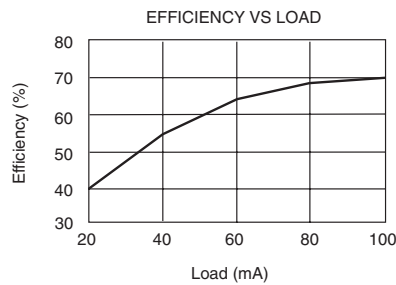
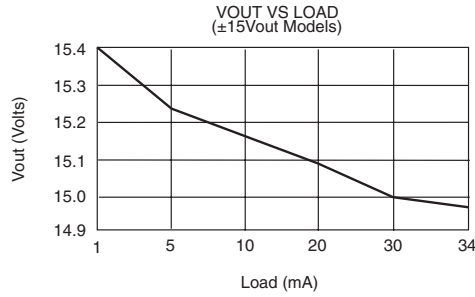
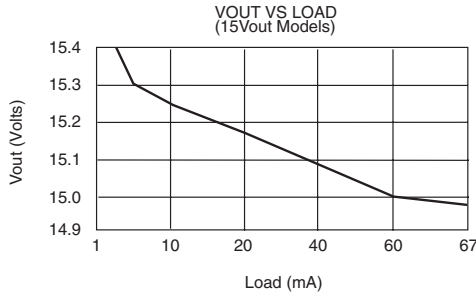
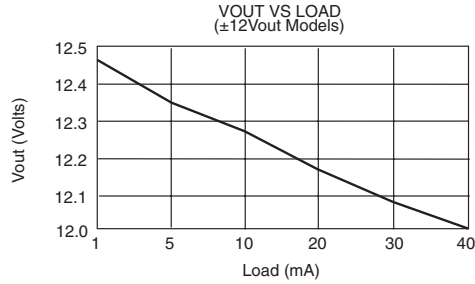
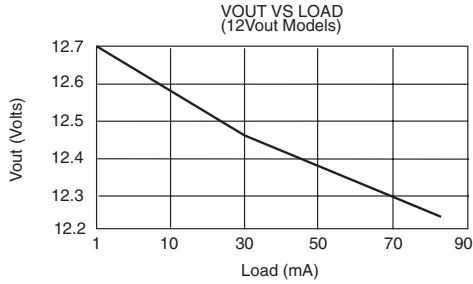
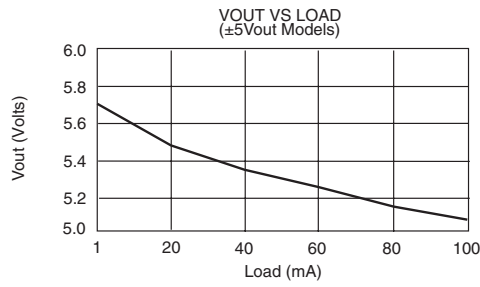
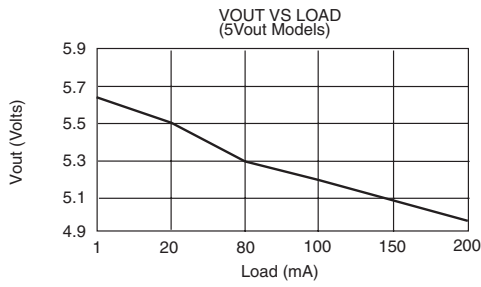

The information provided herein is believed to be reliable; however, Murata Power Solutions assumes no responsibility for inaccuracies or omissions. Murata Power Solutions assumes no responsibility for the use of this information, and all use of such information shall be entirely at the user's own risk. Prices and specifications are subject to change without notice. No patent rights or licenses to any of the circuits described herein are implied or granted to any third party. Murata Power Solutions does not authorize or warrant any Murata Power Solutions product for use in life support devices/systems or in aircraft control applications.



Murata Power Solutions, Inc.  
 11 Cabot Boulevard, Mansfield, MA 02048-1151 U.S.A.  
 Tel: (508) 339-3000 (800) 233-2765 Fax: (508) 339-6356  
 www.murata-ps.com email: sales@murata-ps.com ISO 9001 & ISO 14001 REGISTERED

Murata Power Solutions, Inc. makes no representation that the use of its products in the circuits described herein, or the use of other technical information contained herein, will not infringe upon existing or future patent rights. The descriptions contained herein do not imply the granting of licenses to make, use, or sell equipment constructed in accordance therewith. Specifications are subject to change without notice.  
 © 2008 Murata Power Solutions, Inc.

- USA:** Mansfield (MA), Tel: (508) 339 3000, email: sales@murata-ps.com
- Canada:** Toronto, Tel: (866) 740 1232, email: toronto@murata-ps.com
- UK:** Milton Keynes, Tel: +44 (0)1908 615232, email: mk@murata-ps.com
- France:** Montigny Le Bretonneux, Tel: +33 (0)1 34 60 01 01, email: france@murata-ps.com
- Germany:** München, Tel: +49 (0)89-544334-0, email: ped.munich@murata-ps.com
- Japan:** Tokyo, Tel: 3-3779-1031, email: sales\_tokyo@murata-ps.com  
 Osaka, Tel: 6-6354-2025, email: sales\_osaka@murata-ps.com
- China:** Shanghai, Tel: +86 215 027 3678, email: shanghai@murata-ps.com  
 Guangzhou, Tel: +86 208 221 8066, email: guangzhou@murata-ps.com
- Singapore:** Parkway Centre, Tel: +65 6348 9096, email: singapore@murata-ps.com